

ÉCOLE D'APPLICATION D'ARTILLERIE

Ché Medeville

95078

Instruction Militaire

CROQUIS du CANON de 75 M^{le} 1897



1929

Lithographie de l'École d'Application d'Artillerie

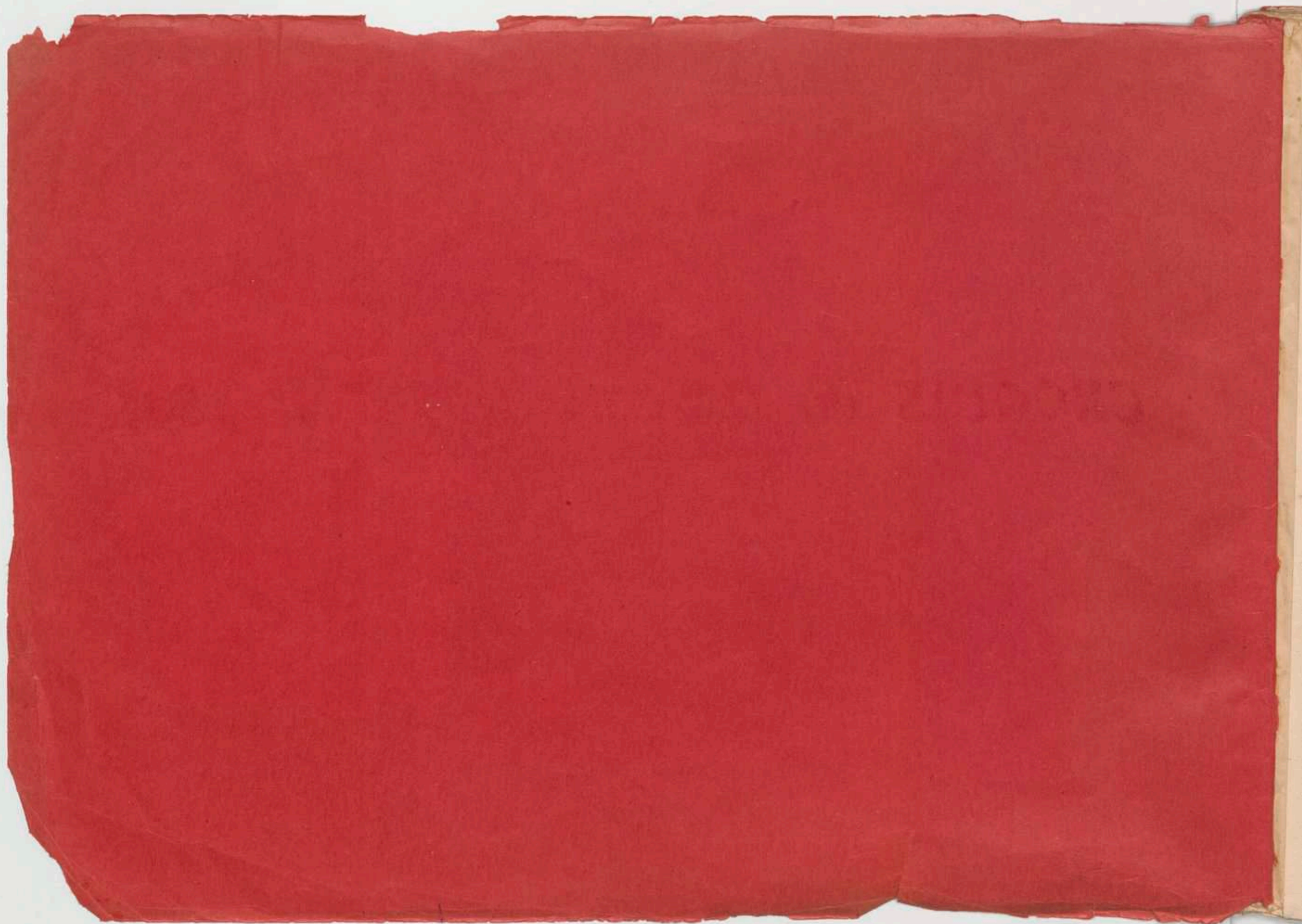

ÉCOLE D'APPLICATION D'ARTILLERIE

Instruction Militaire

CROQUIS du CANON de 75 M^{le} 1897

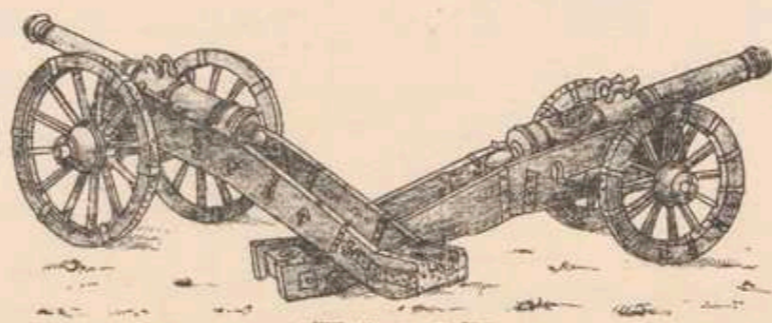
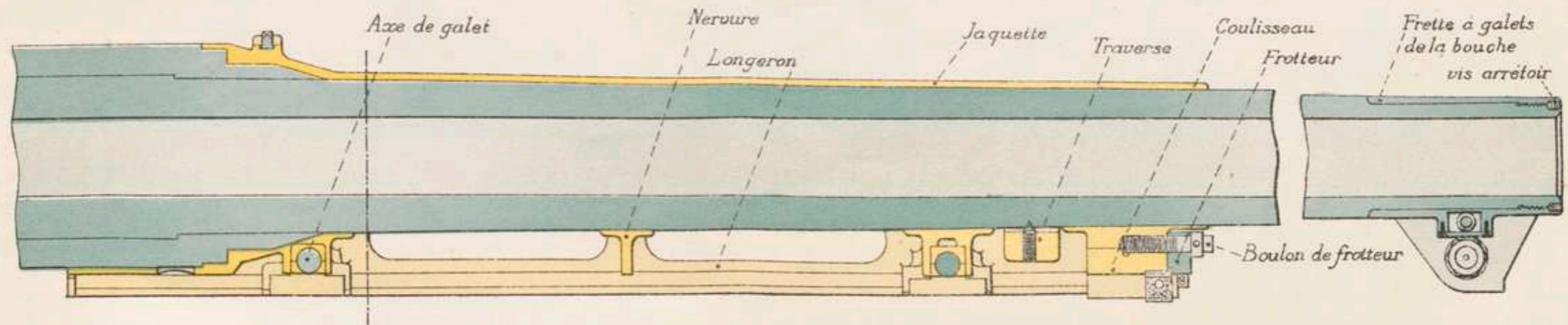
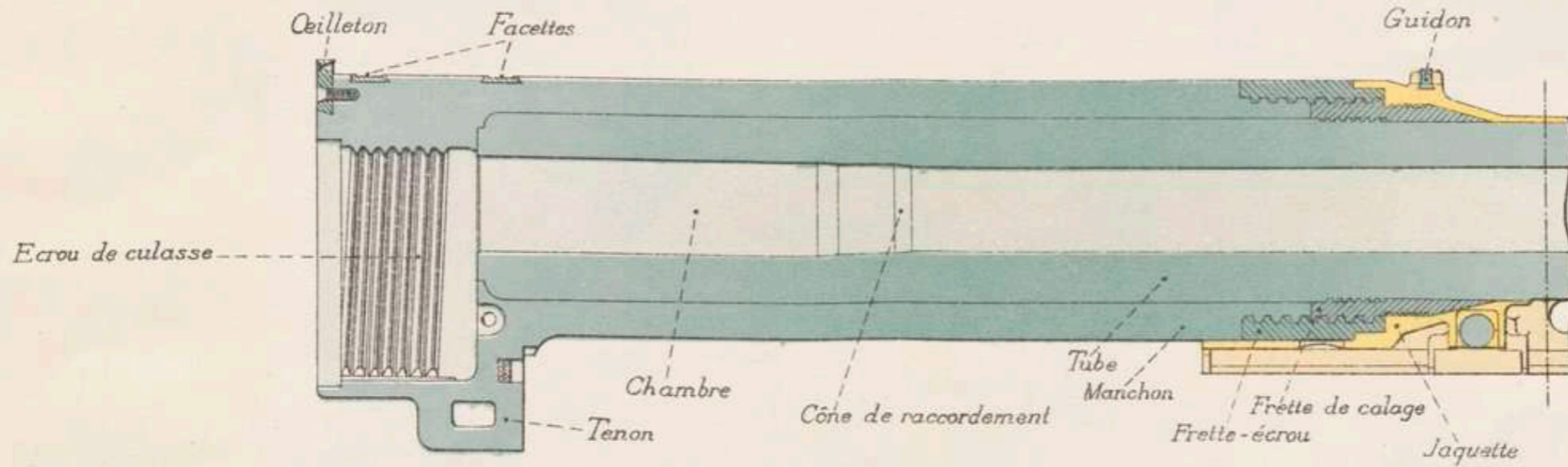
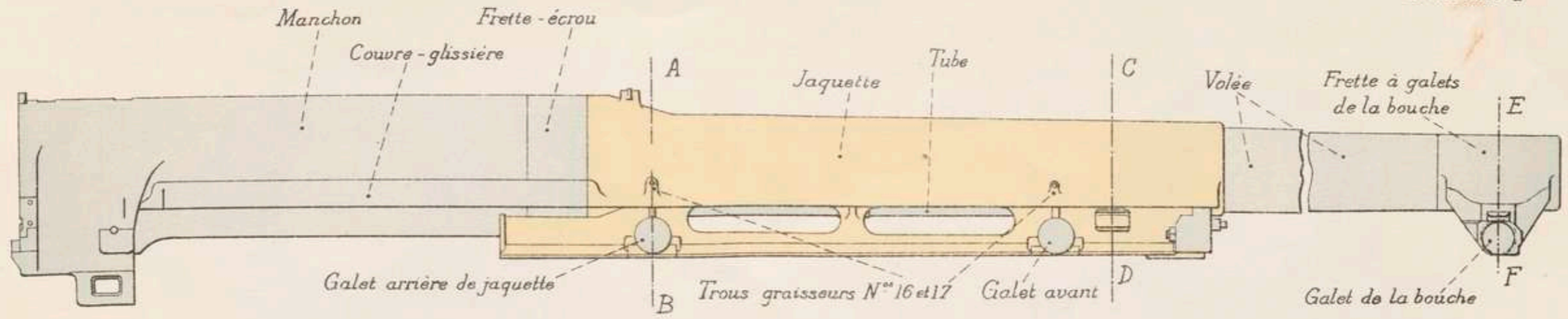

TABLE DES PLANCHES

		PLANCHES			PLANCHES	
<i>BOUCHE A FEU</i>	<i>Ensemble. - Coupe longitudinale.</i>	I	<i>AFFUT</i>	<i>Coupe longitudinale.</i>	XX	
	<i>Coupes transversales.</i>	II		<i>Commandes de pointage.</i>	XXI	
	<i>Jaquette.</i>	III		<i>Système de pointage en hauteur.</i>	XXII	
	<i>Manchon.</i>	IV		<i>Système de pointage en direction.</i>	XXIII	
<i>CULASSE</i>	<i>Butée-guide. - Rampes.</i>	V	<i>ESSIEU ET ROUES</i>		XXIV	
	<i>Coupe. - Vue arrière.</i>	VI		<i>FREIN DE ROUES</i>	<i>Châssis.</i>	XXV
	<i>Fonctionnement du linguet.</i>	VII	<i>Articulations du châssis.</i>		XXVI	
<i>ORGANES RELIANT LE CANON AU FREIN</i>	<i>Clavette.</i>	VII	<i>Accrochage du châssis.</i>			
	<i>Verrou de clavette.</i>	VIII	<i>Frein de route.</i>	XXVII		
	<i>Frotteur et coulisseau.</i>	IX	<i>AVANT-TRAIN</i>	<i>Ensemble.</i>	XXVIII	
<i>FREIN DE TIR</i>	<i>Plan. - Schéma du recul.</i>	X		<i>Coupes.</i>	XXIX	
	<i>Coupe longitudinale.</i>	XI ¹	<i>ARRIÈRE-TRAIN DE CAISSON</i>	<i>Ensemble.</i>	XXX	
	<i>Détails.</i>	XI ^{bis}		<i>Coupe longitudinale.</i>	XXXI	
	<i>Amortisseur. Orifice de remplissage</i>	XII		<i>Coupe par l'essieu.</i>	XXXII	
	<i>BERCEAU DE POINTAGE</i>	<i>Raccord du tourillon droit.</i>	XIII	<i>DÉBOUCHOIR</i>	<i>Mouvement.</i>	XXXIII
		XIV	<i>Porte-lame.</i>		XXXIV	
<i>HAUSSE</i>	<i>Commande de hausse.</i>	XIV	<i>POMPE DE BATTERIE. REMP LISSEUR A VIS. - AJUTAGE.</i>		XXXV	
	<i>Tambour de hausse.</i>	XV		<i>TIMON</i>		XXXVI
<i>APPAREIL DE POINTAGE</i>	<i>Ensemble.</i>	XVI	<i>GALERIE PORTE-SACS. - SAC AUX ARMEMENTS. REFOULOIR.</i>			XXXVII
	<i>Support de pointage. - Élévation.</i>	XVII				
	<i>Support de pointage. - Plan.</i>	XVIII				
	<i>Colonne.</i>	XIX				

Canon

Planche I



Coupe AB
(v. pl. I.)

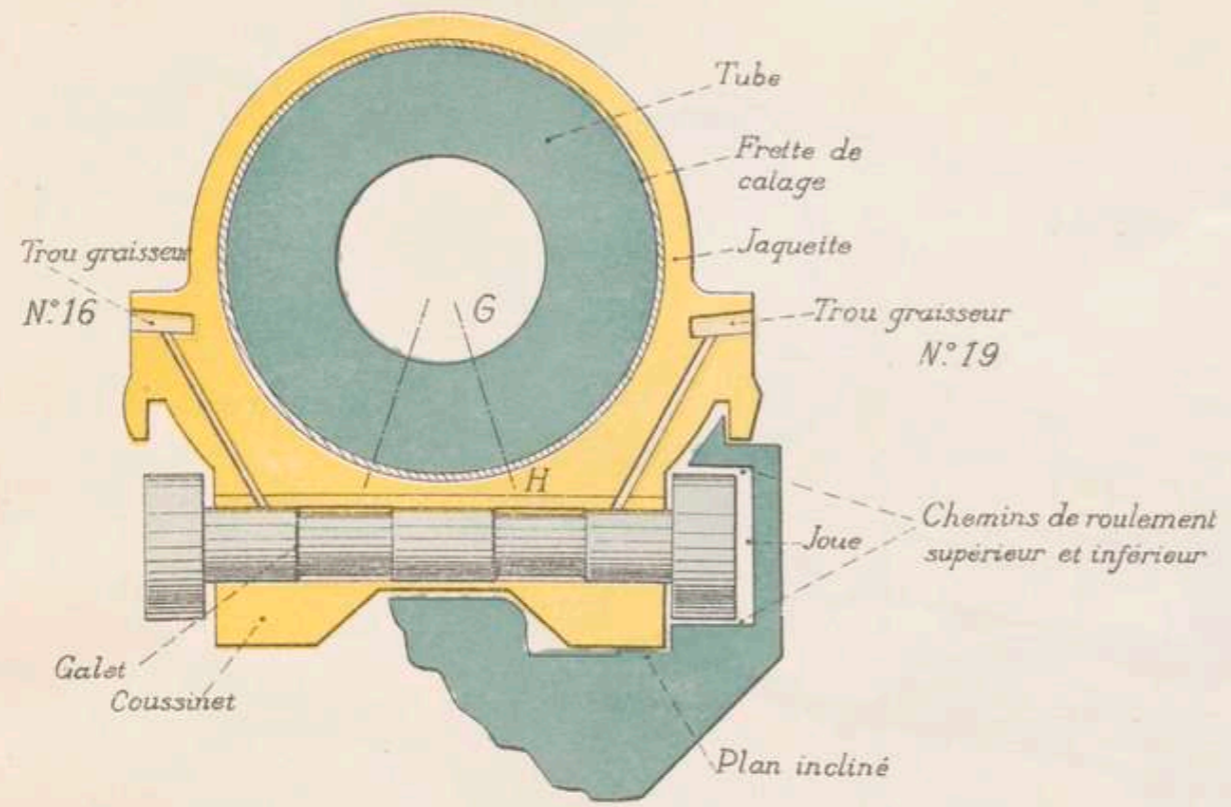

Coupe CD
(v. pl. I.)

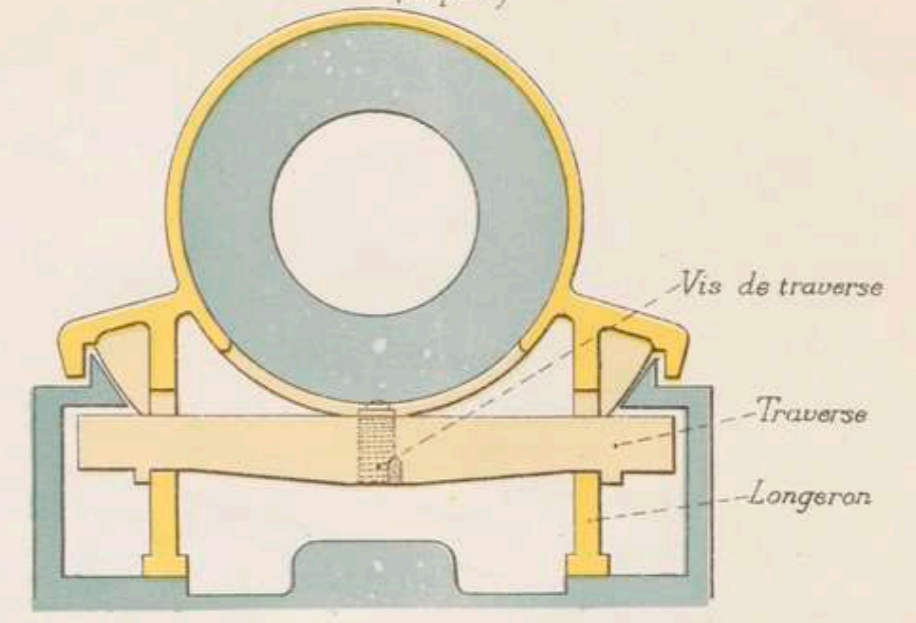

Coupe EF

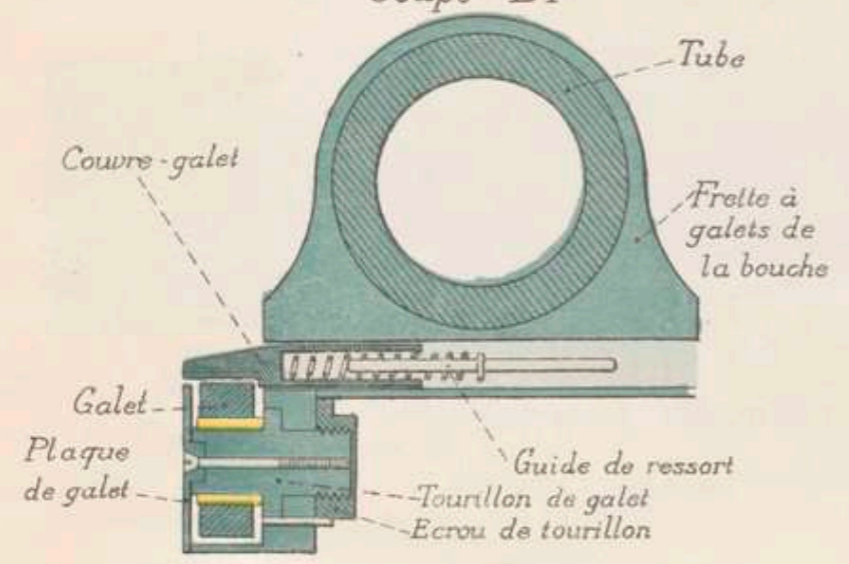

Détail d'un trou graisseur

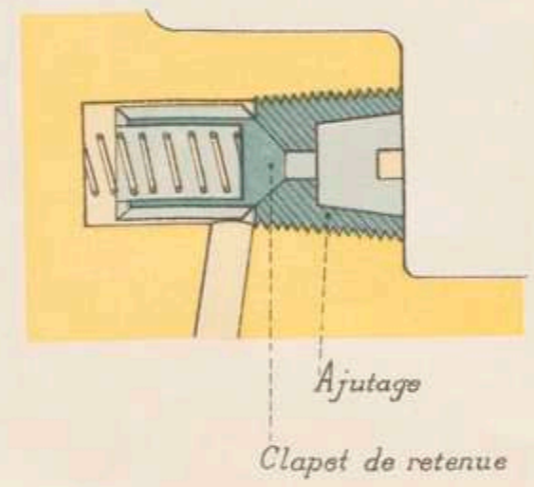

Vue avant
Numérotage des rayures

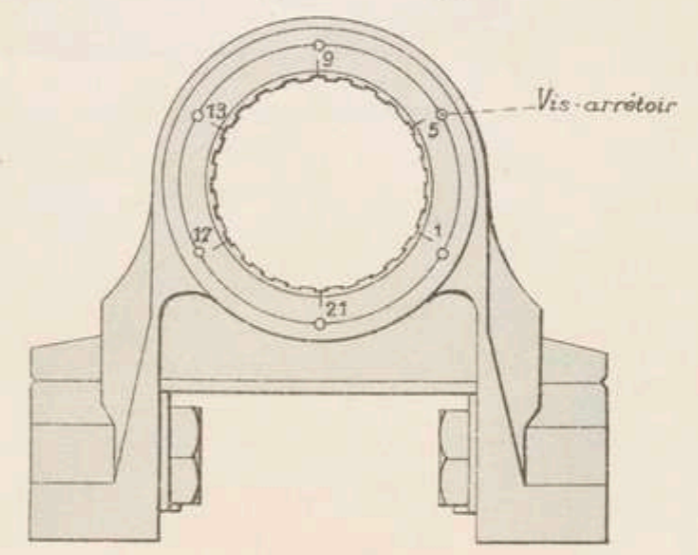

Jaquette

Planche III

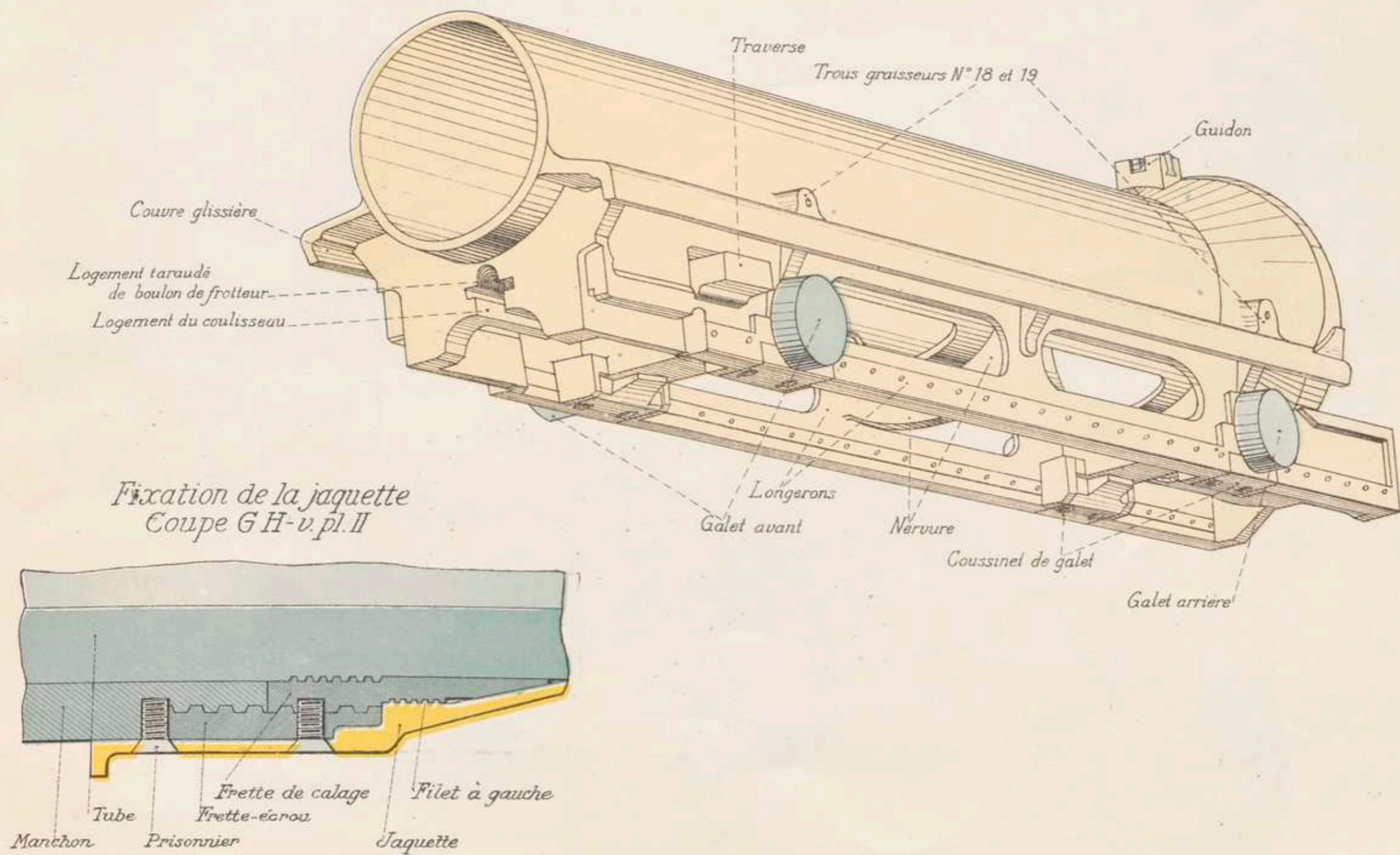

Arrière du manchon

Planche IV

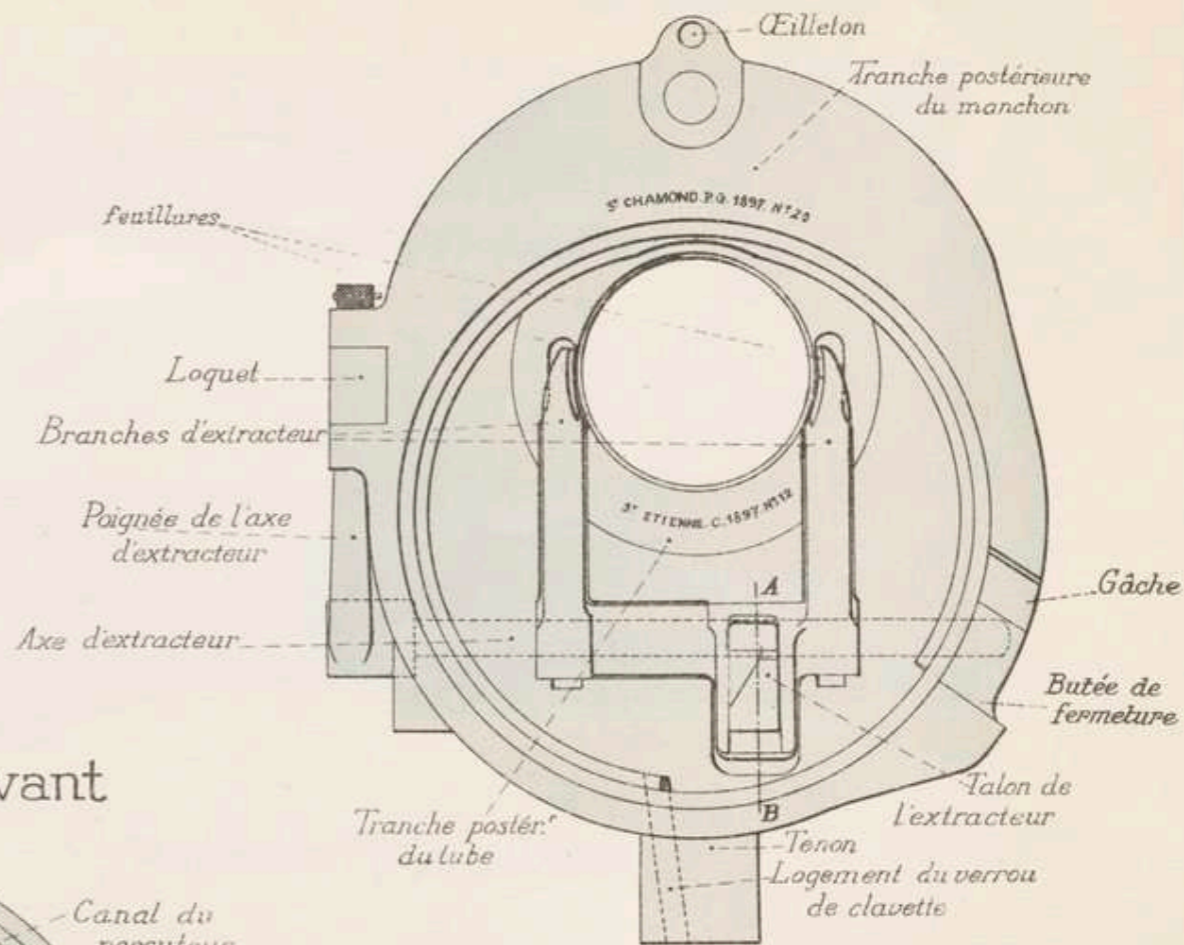
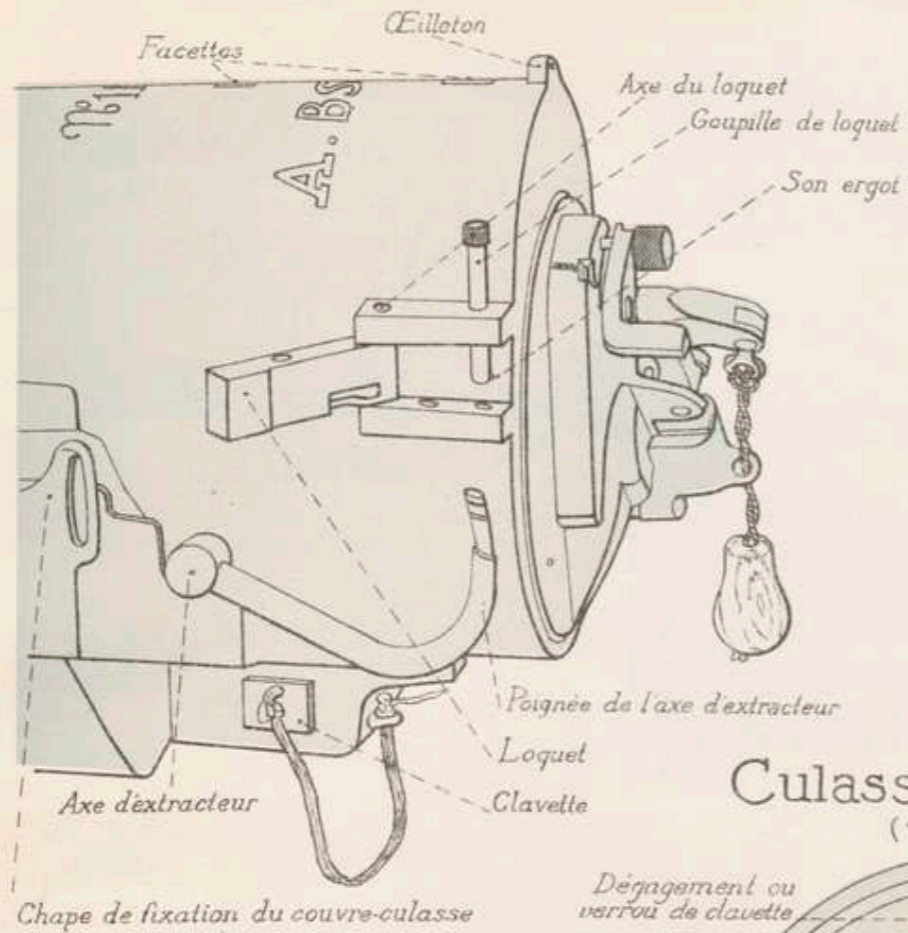

Culasse - Vue avant (v. pl. V)

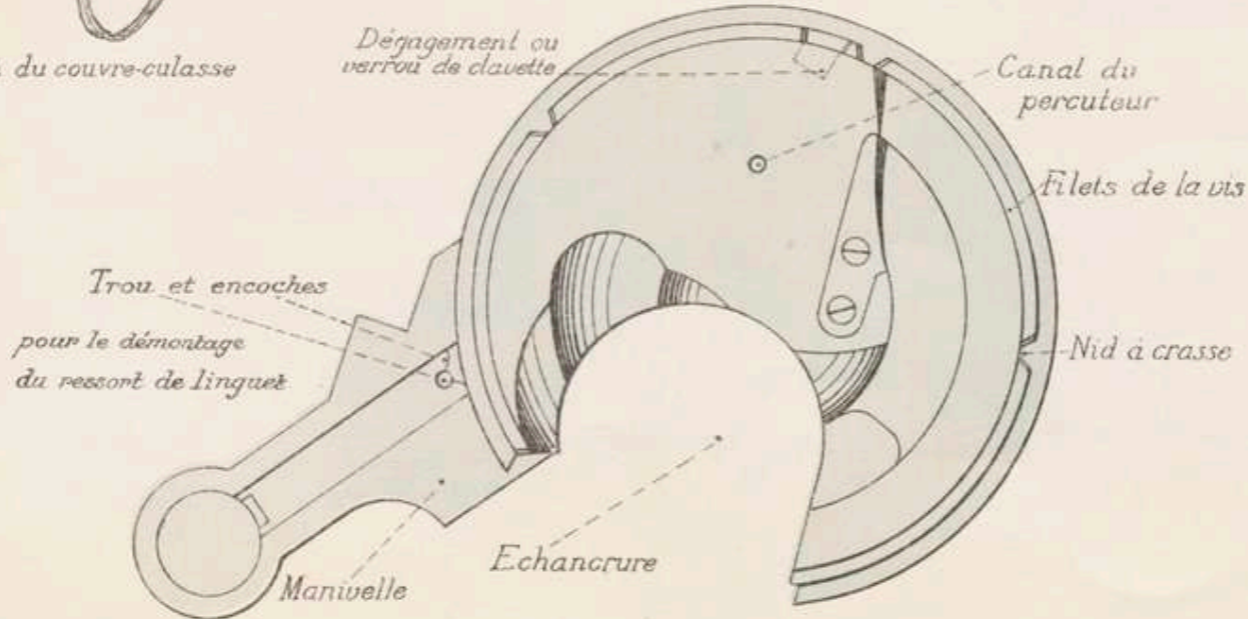

Coupe A.B.

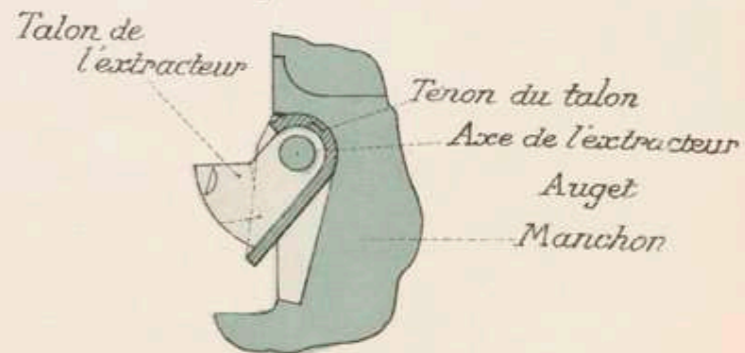

Butée - guide

Planche V

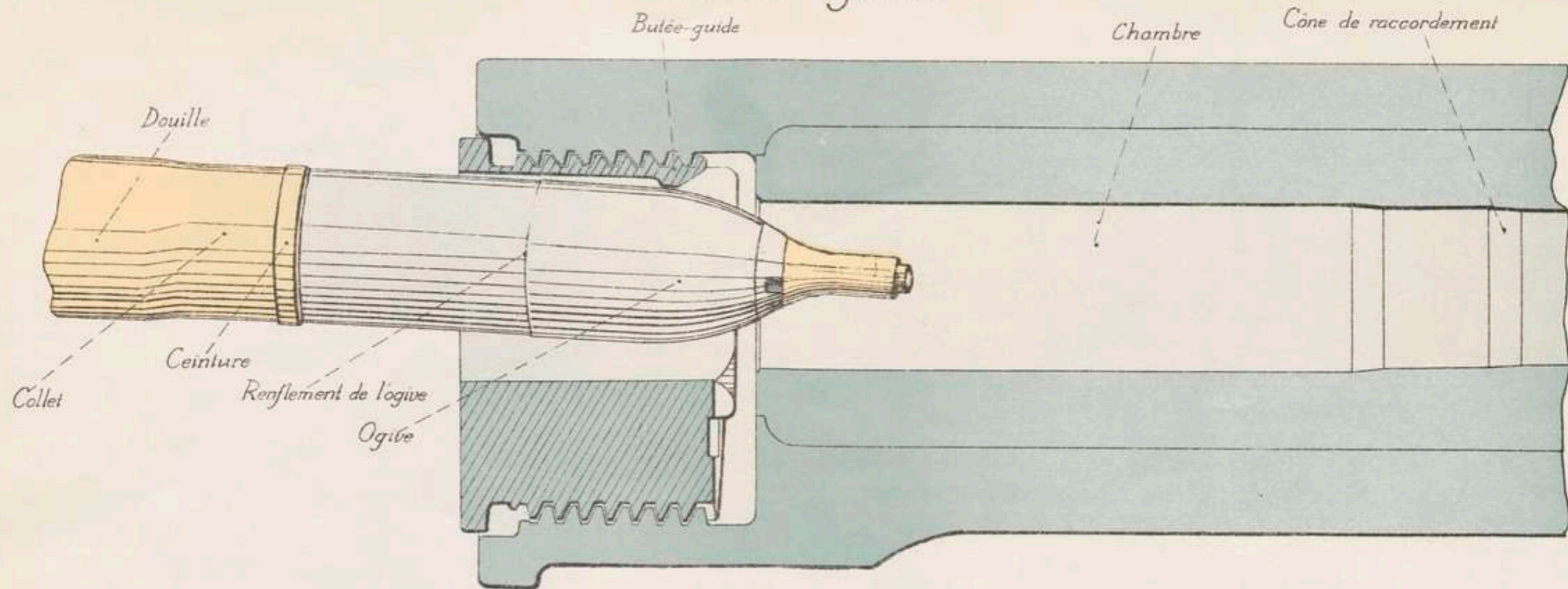

Rampes de la culasse

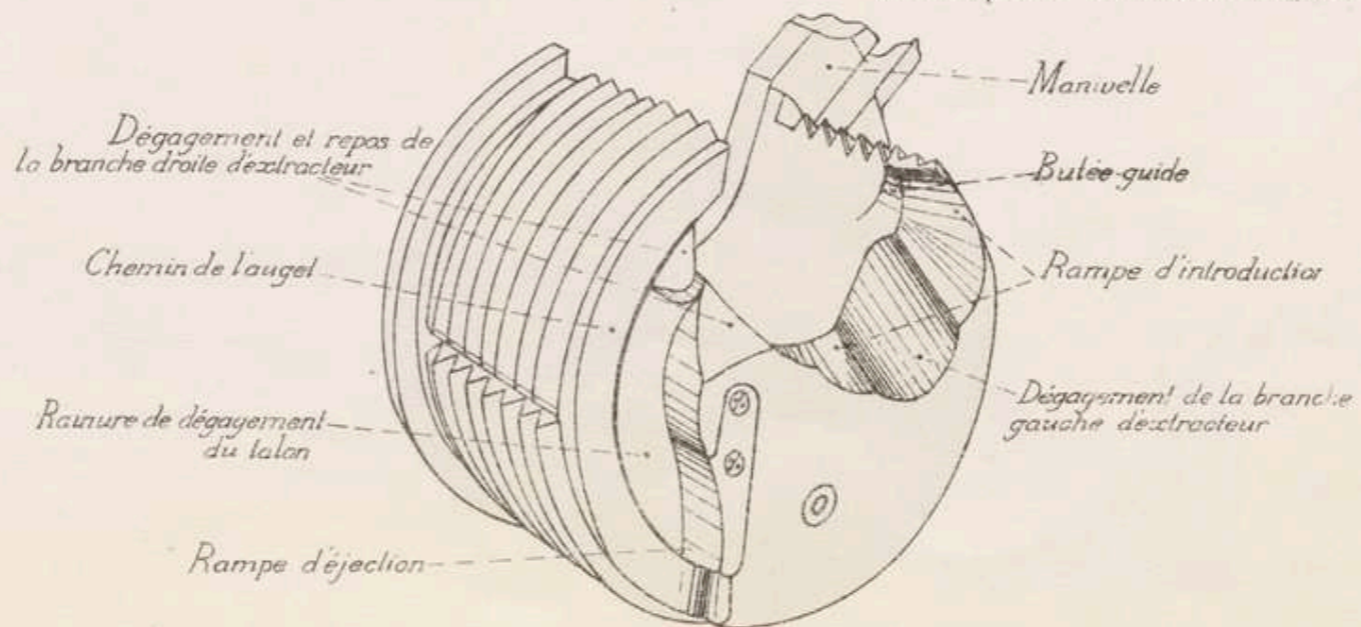

Coupe AB

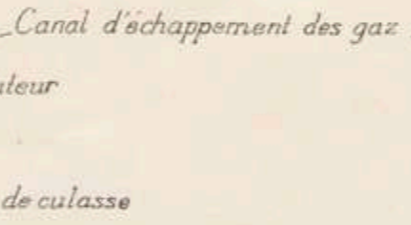
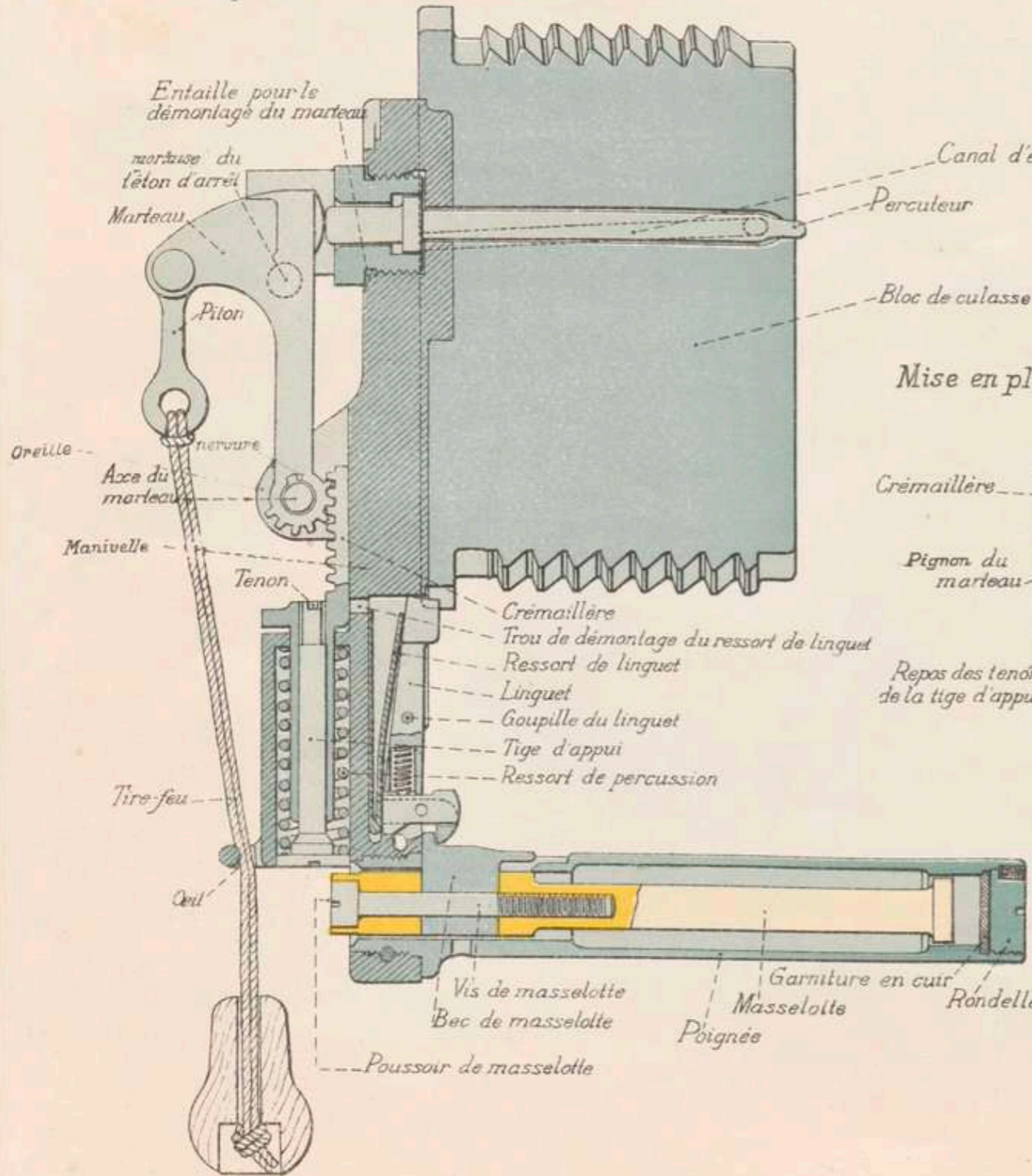

Mise en place du marteau

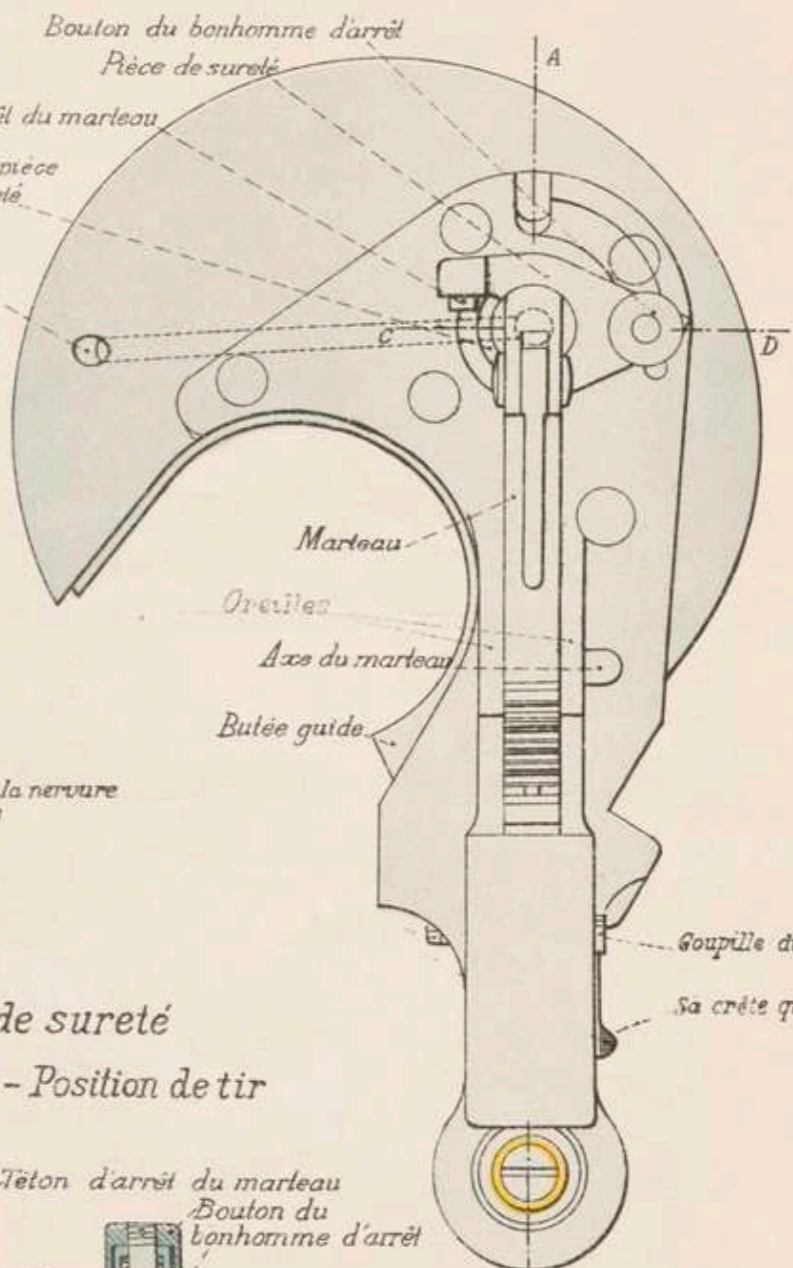
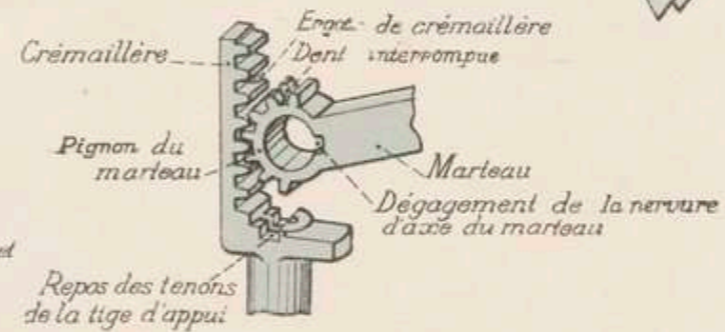

Pièce de sûreté
Coupe CD - Position de tir

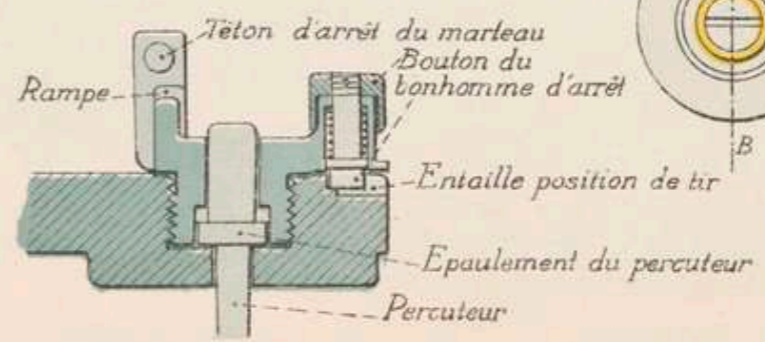

Fonctionnement du linguet

Liaison du canon et du frein

Planche VII

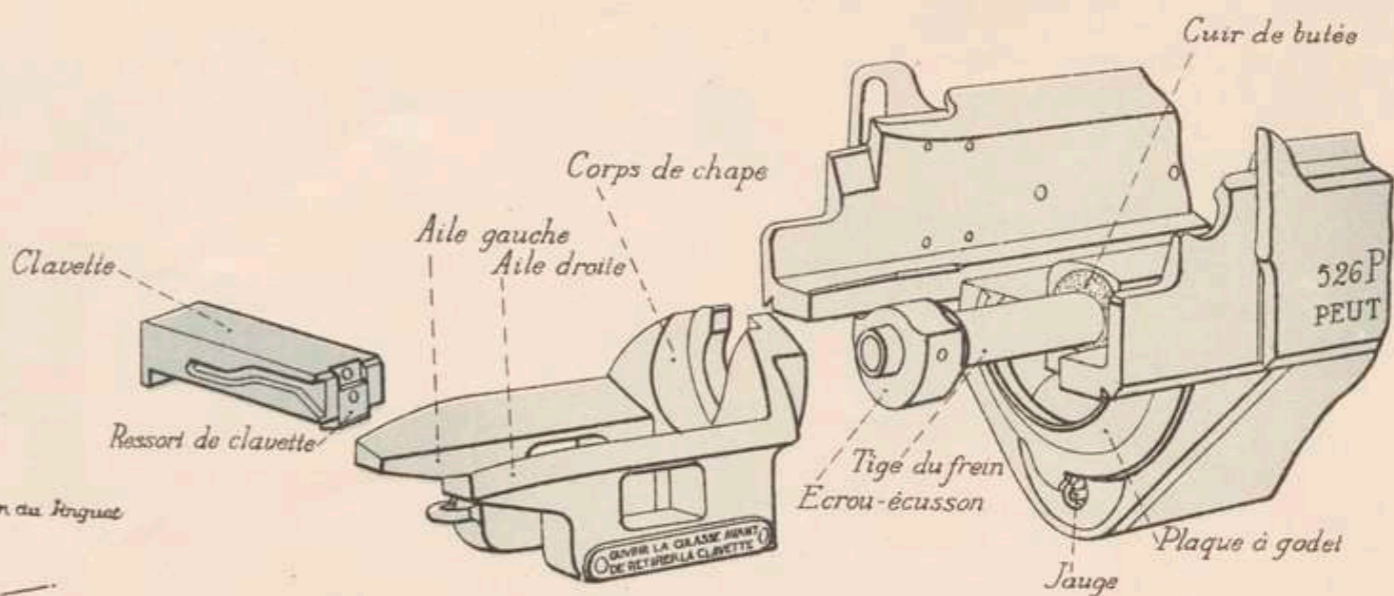
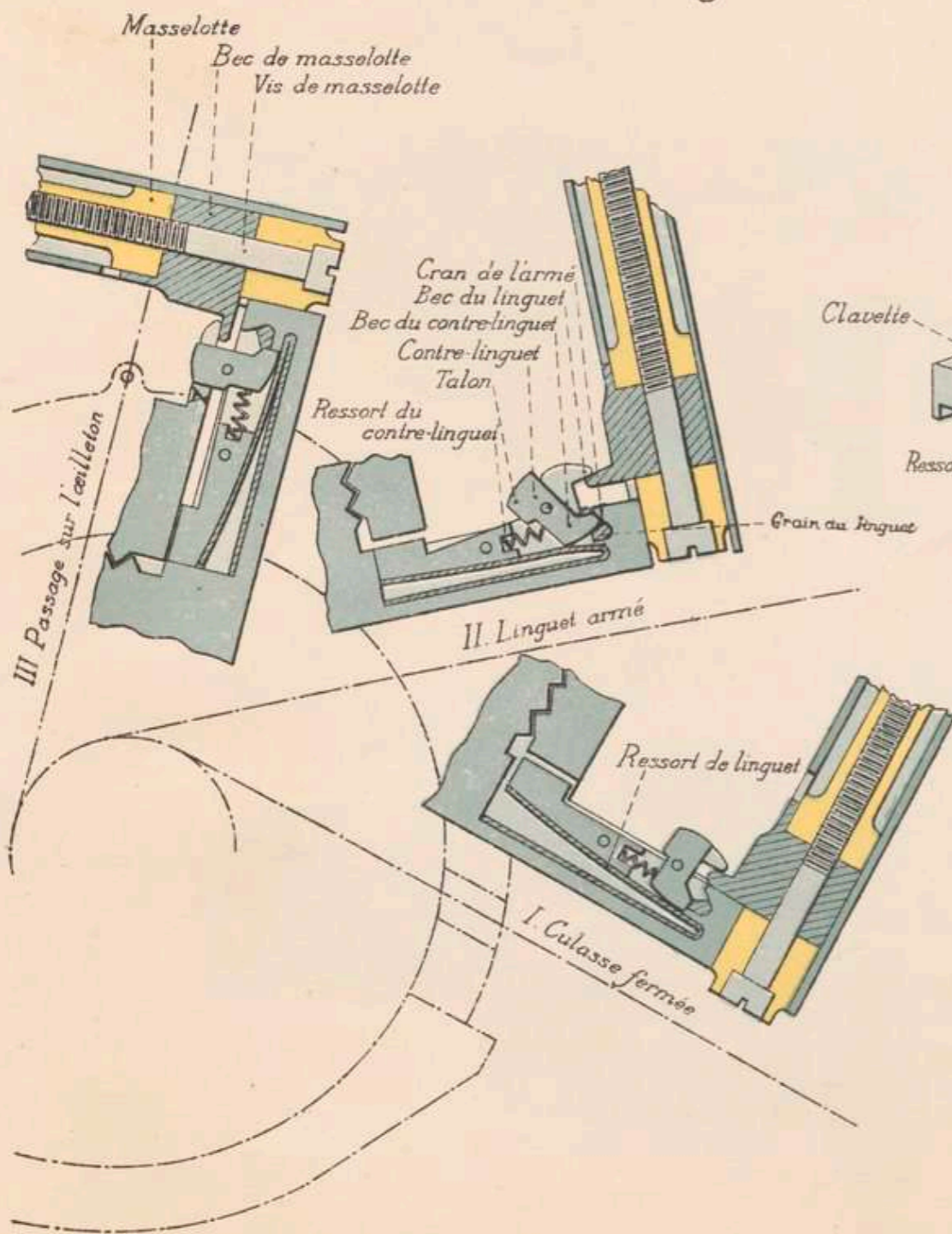

Traits de repere - Marques du frein

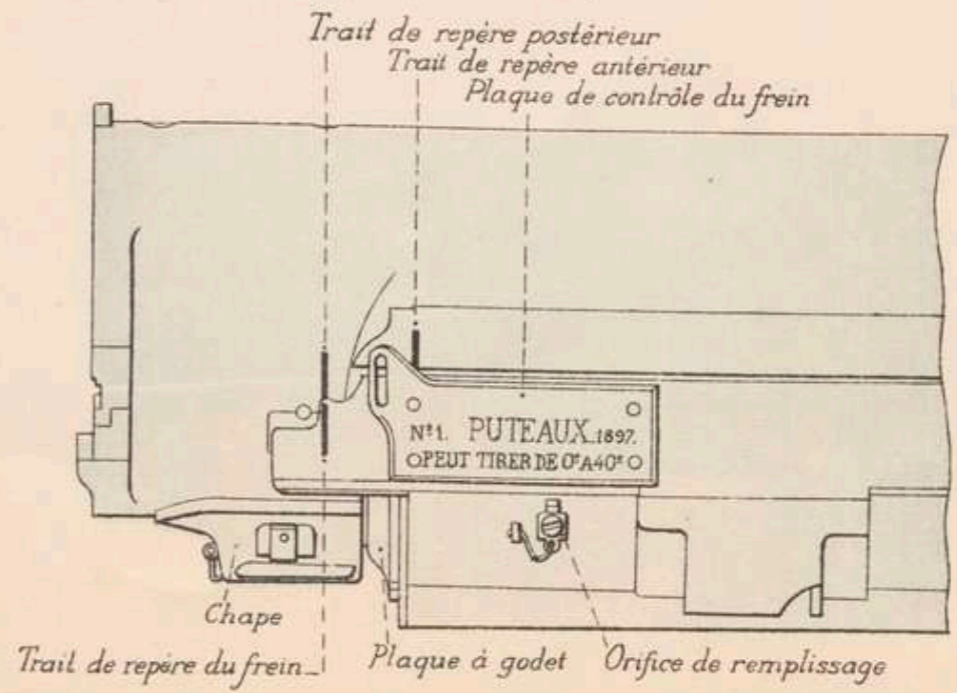

I. Culasse fermée - Canon claveté

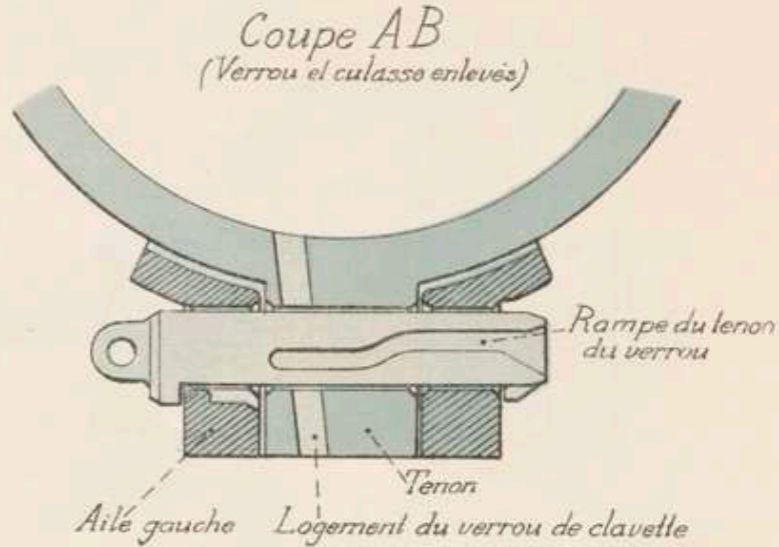
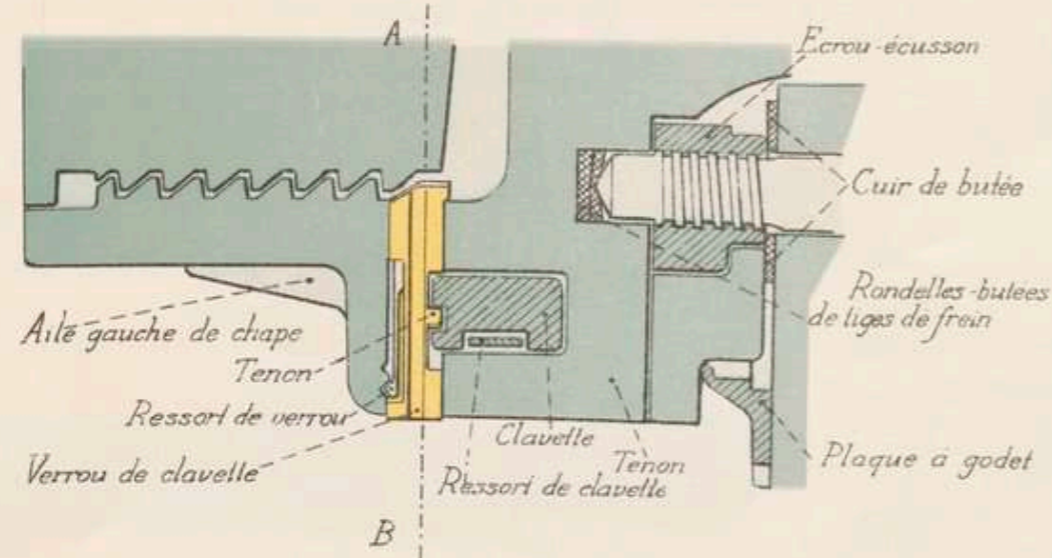

II. Culasse ouverte - Canon déclaveté

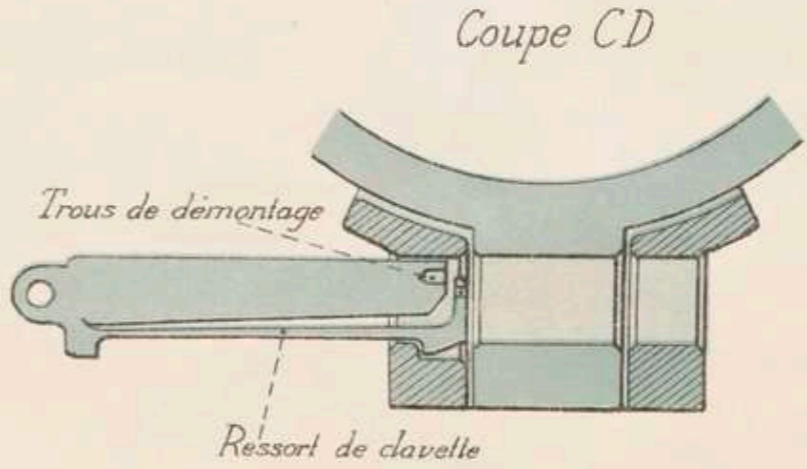
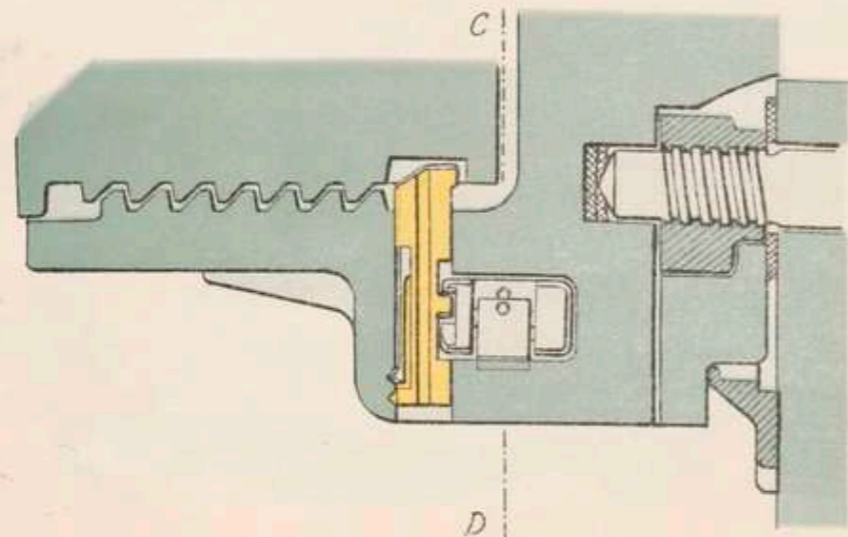

Frotteur et coulisseau

Coupe par la tranche antérieure du coulisseau

Vue avant

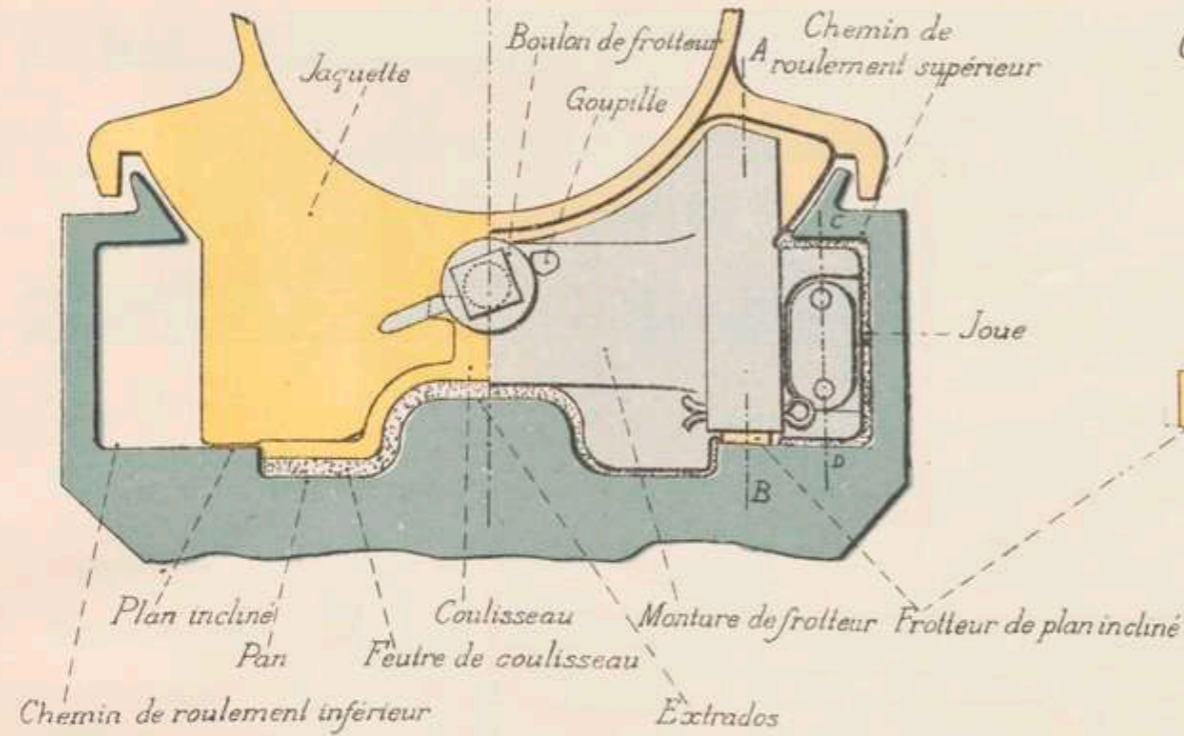

Coupe AB

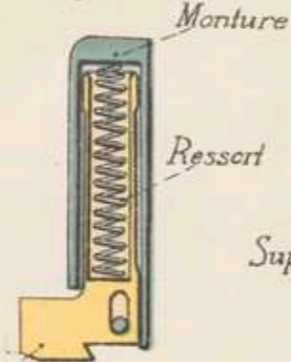

Coupe CD

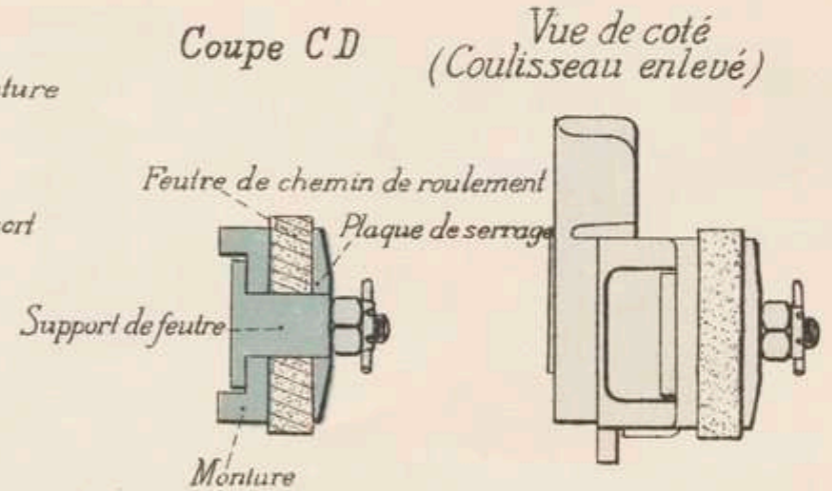

Vue de côté (Coulisseau enlevé)

Ensemble vu par l'arrière

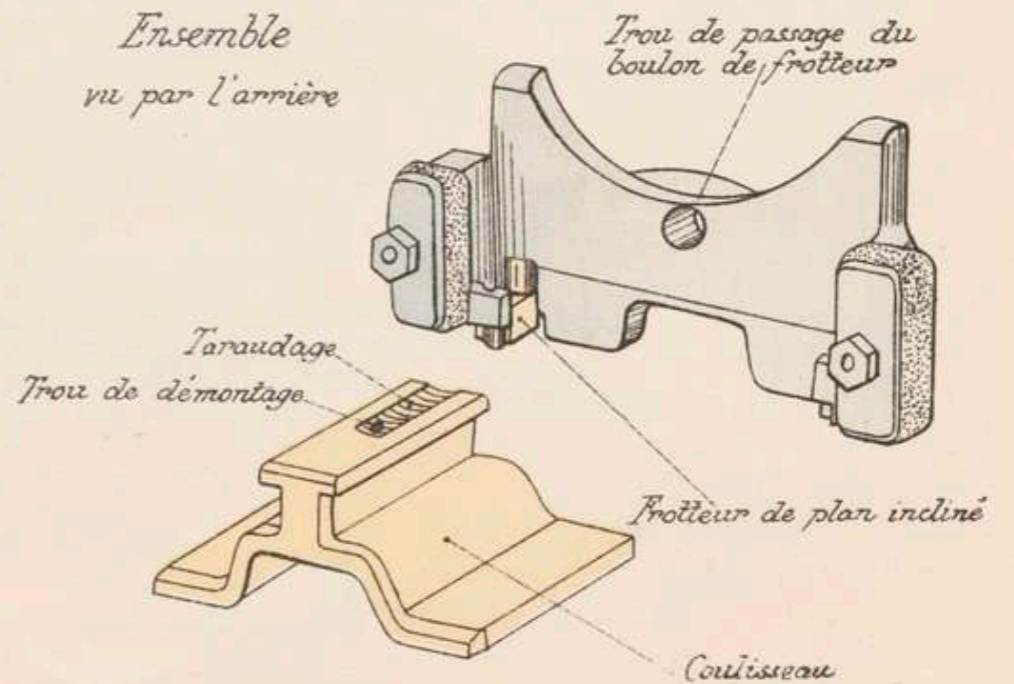

Frotteur - Plan

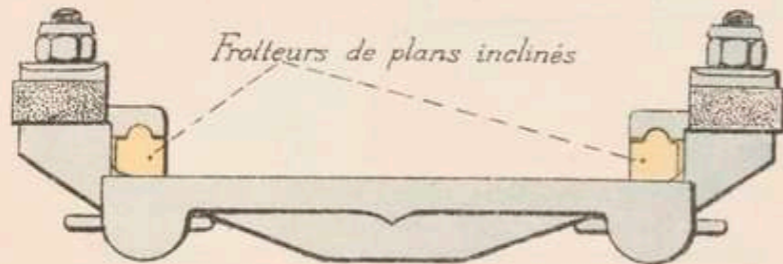

Glissière

Planche X



Schéma du recul

I - Avant le recul

II - Au début du recul

III - A la fin du recul

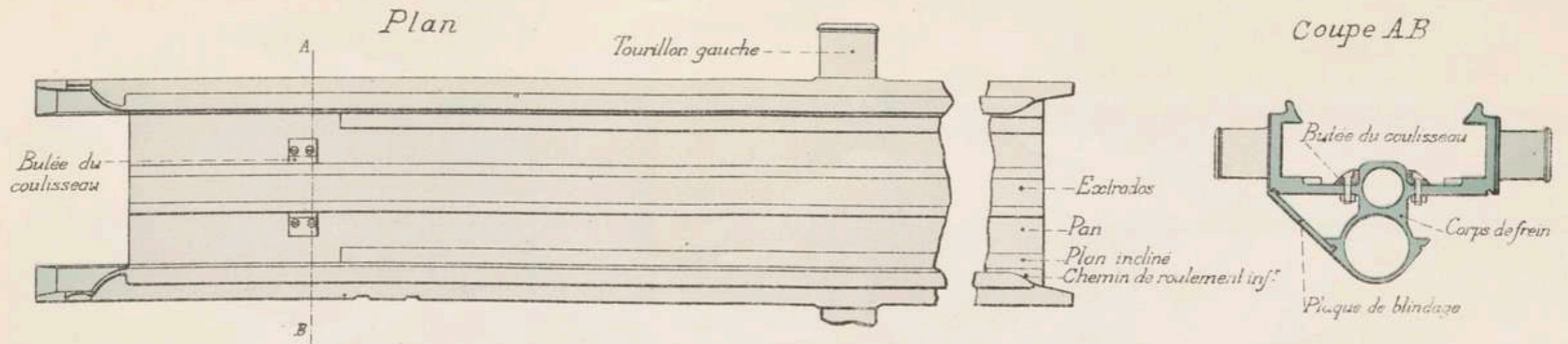
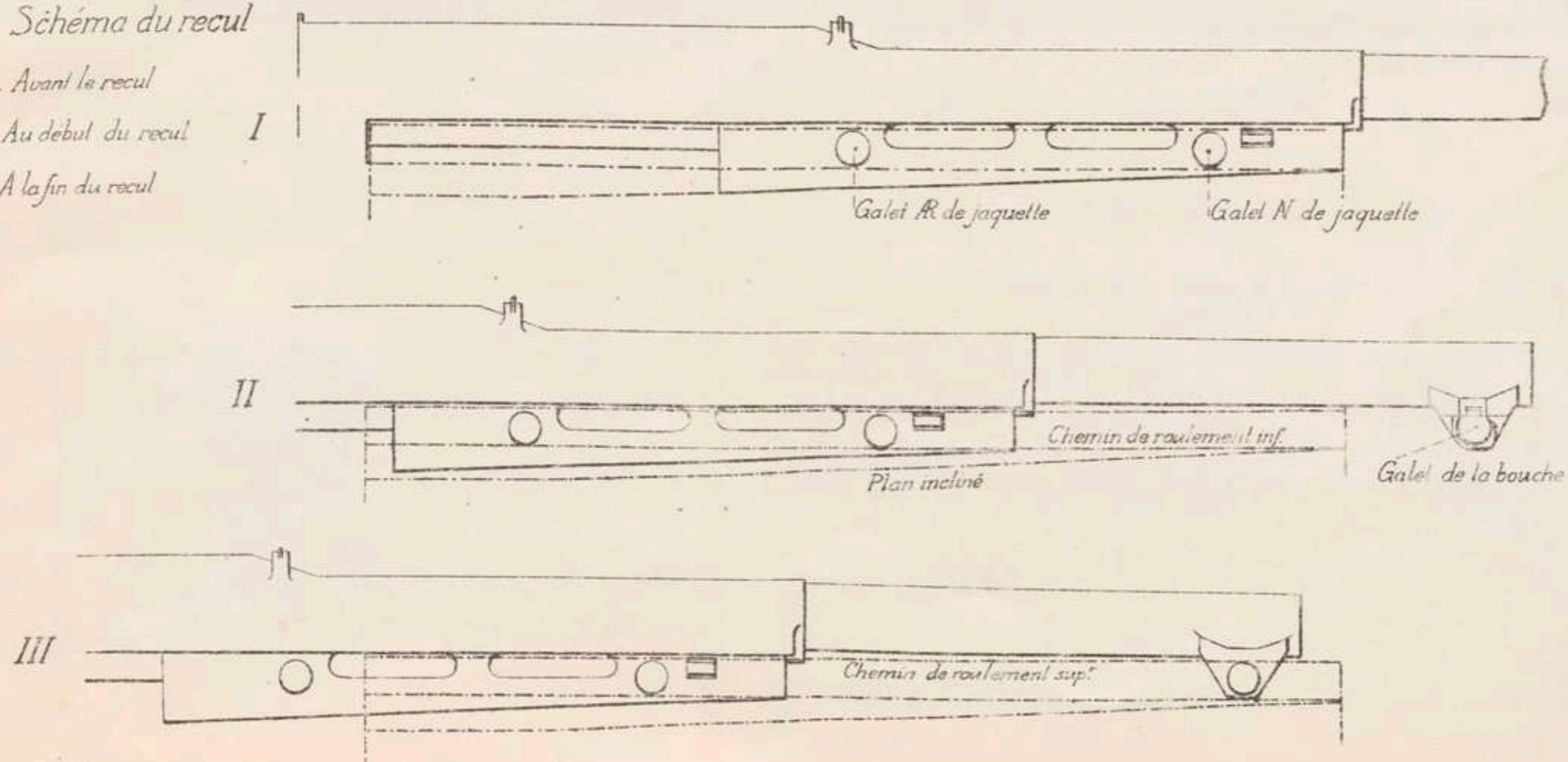

Frein de tir

Planche XI

Partie arrière

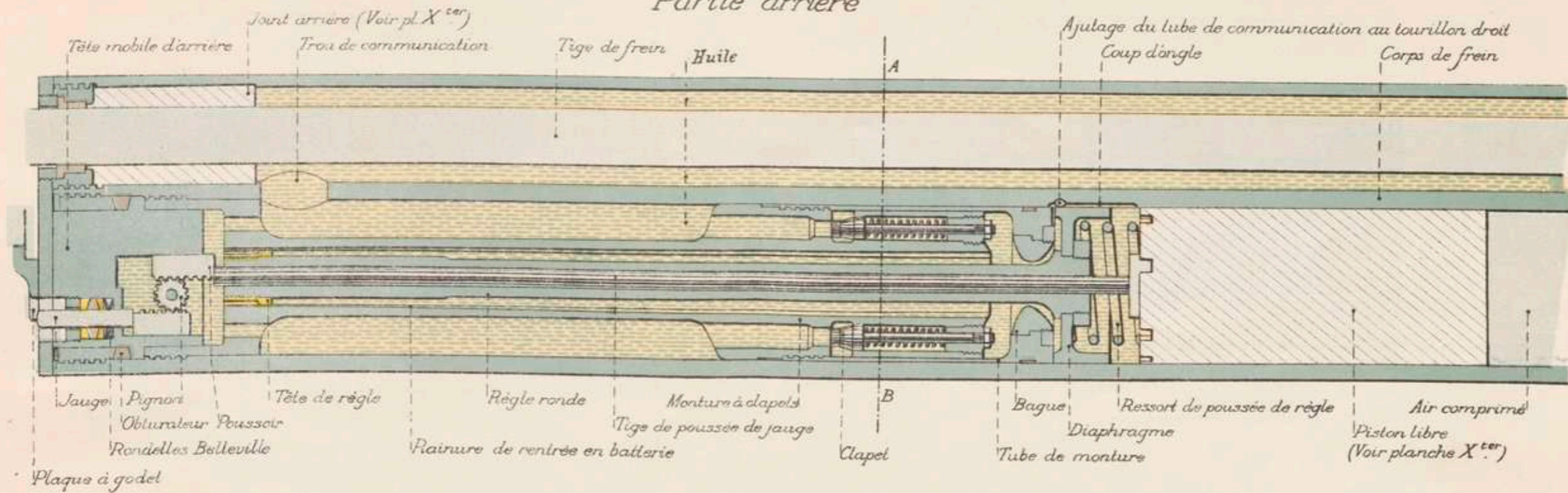

Coupe AB

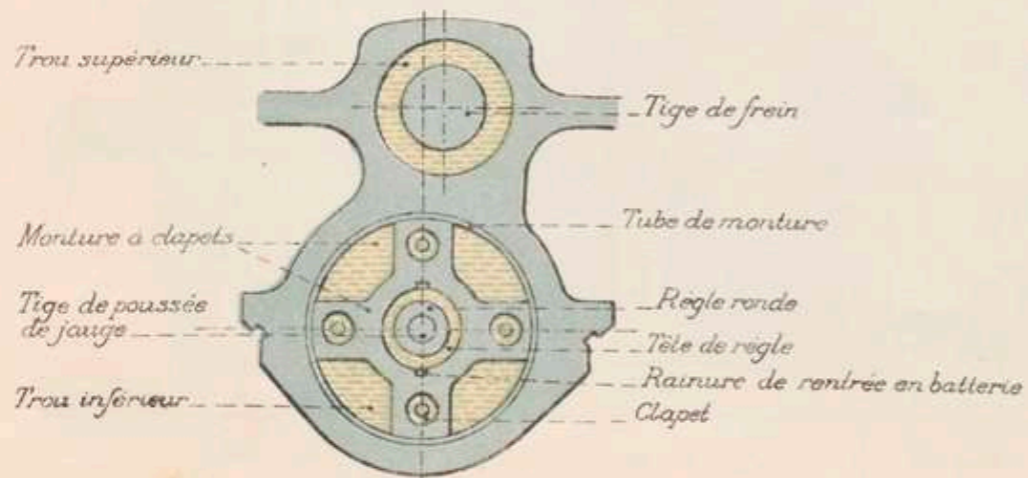

Partie-avant

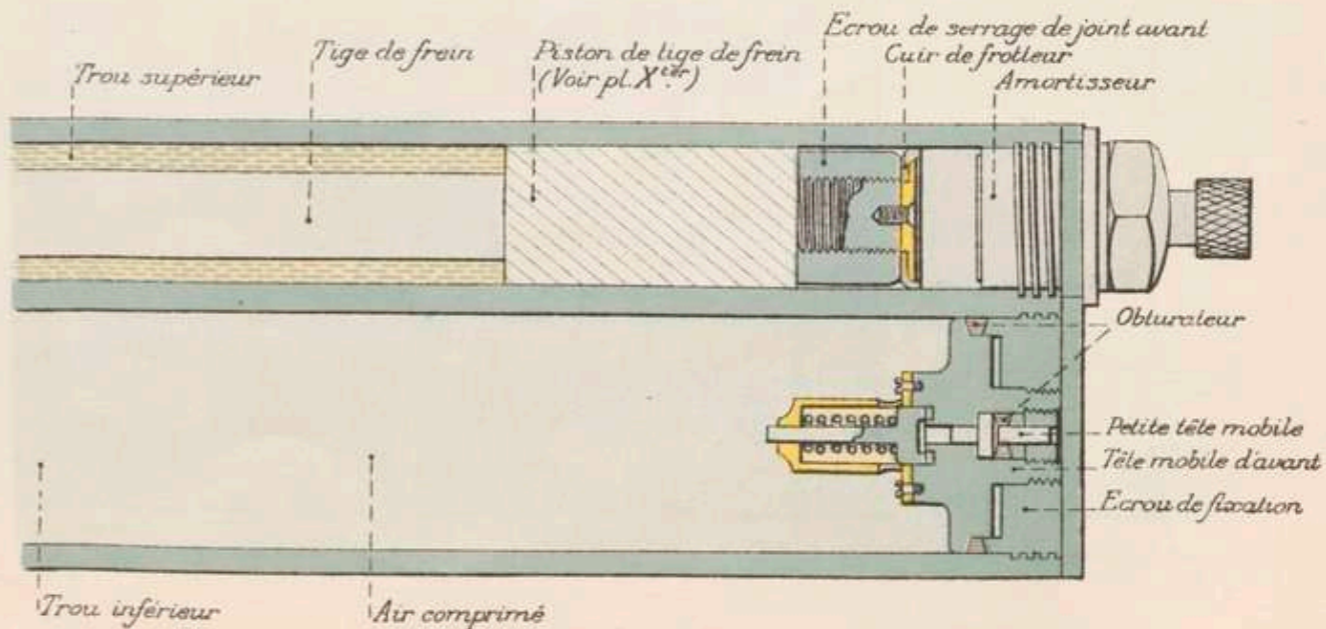

Détails du frein de tir

Planche XI^{bis}

Joint arrière de tige de frein

Piston de tige de frein

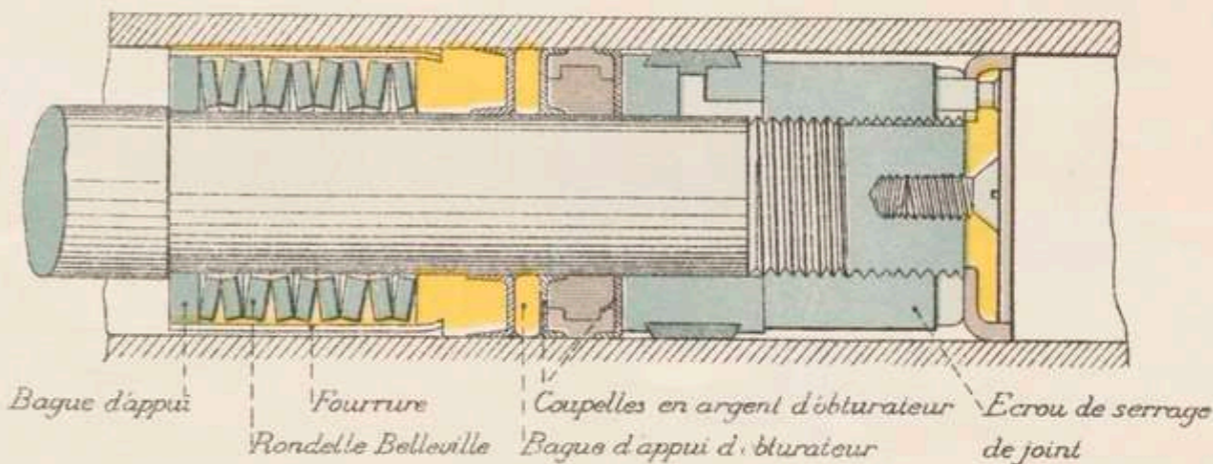
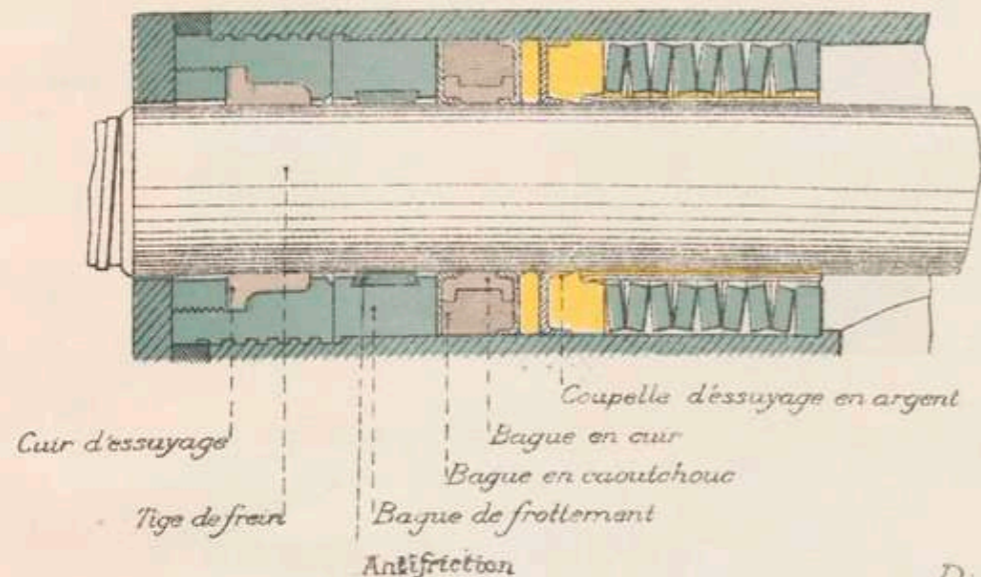

Piston libre

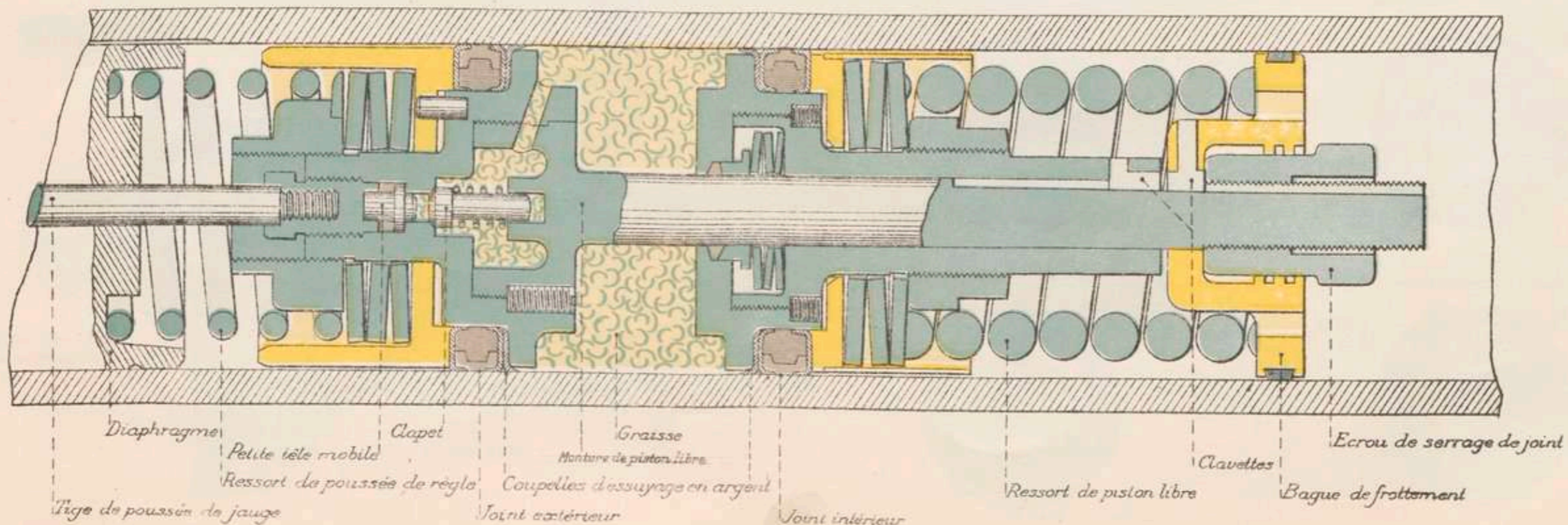

Amortisseur

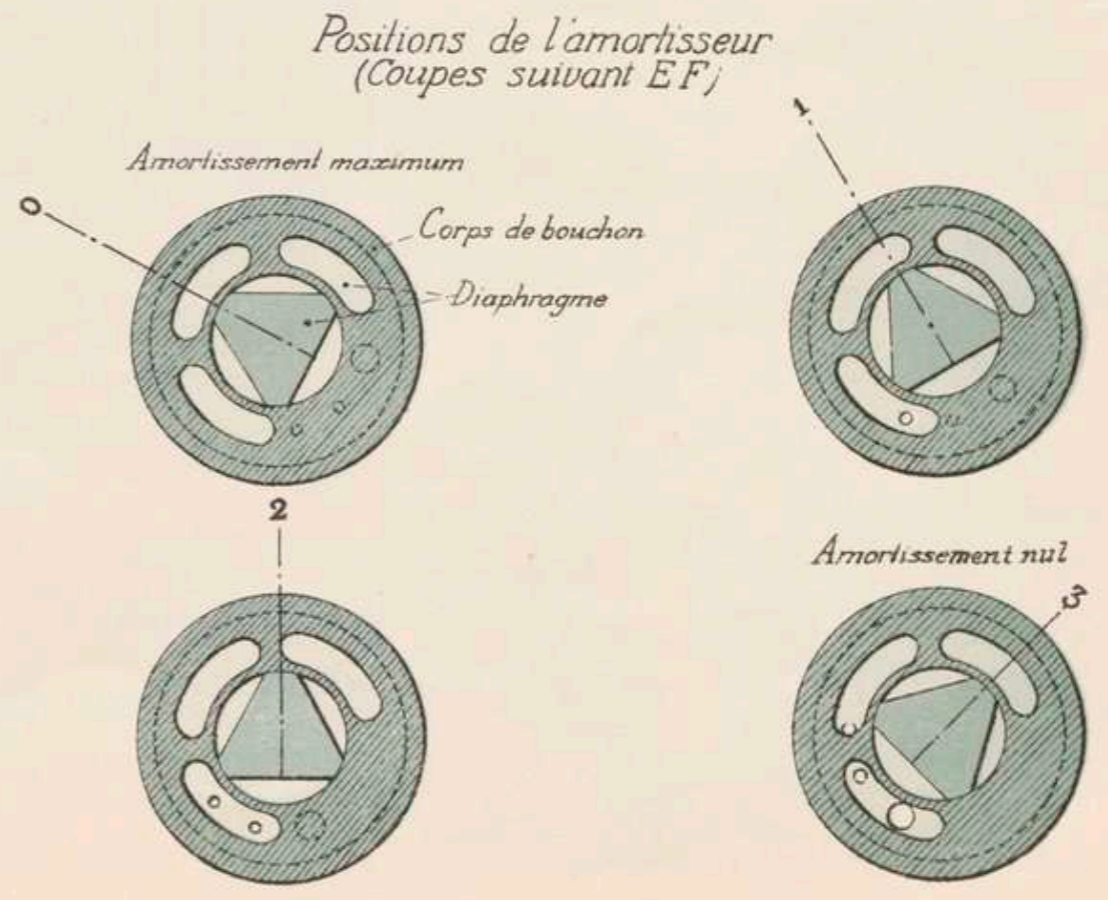
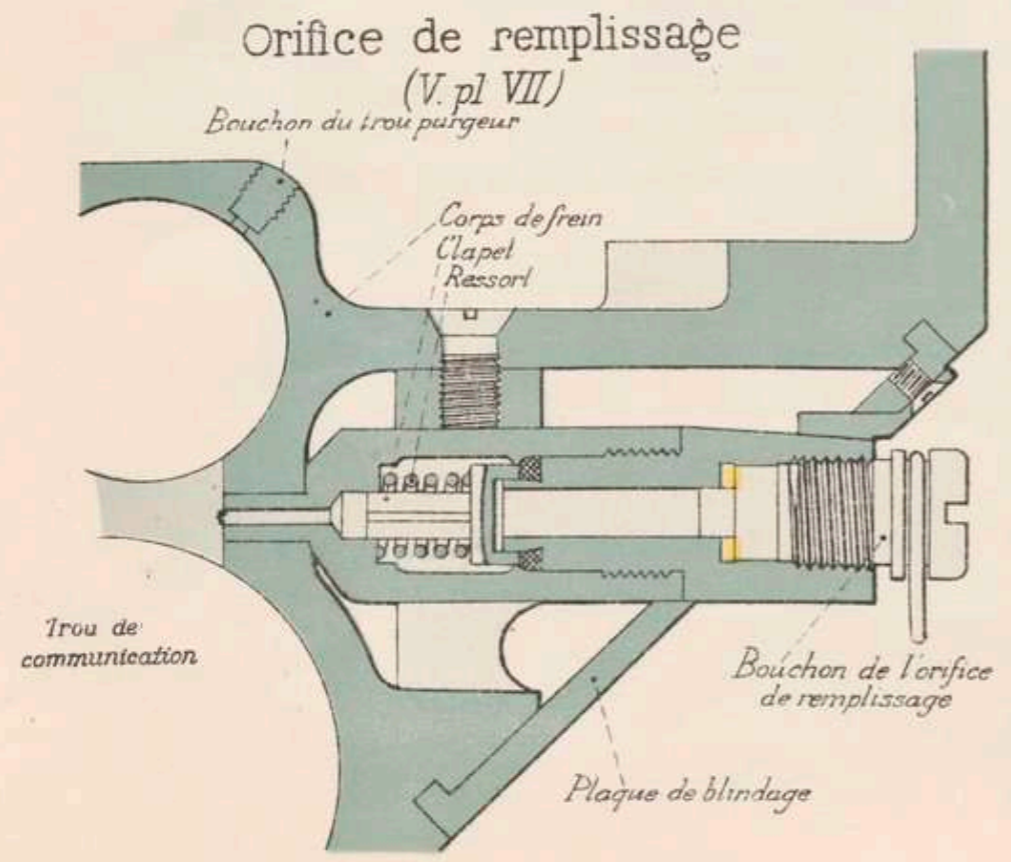
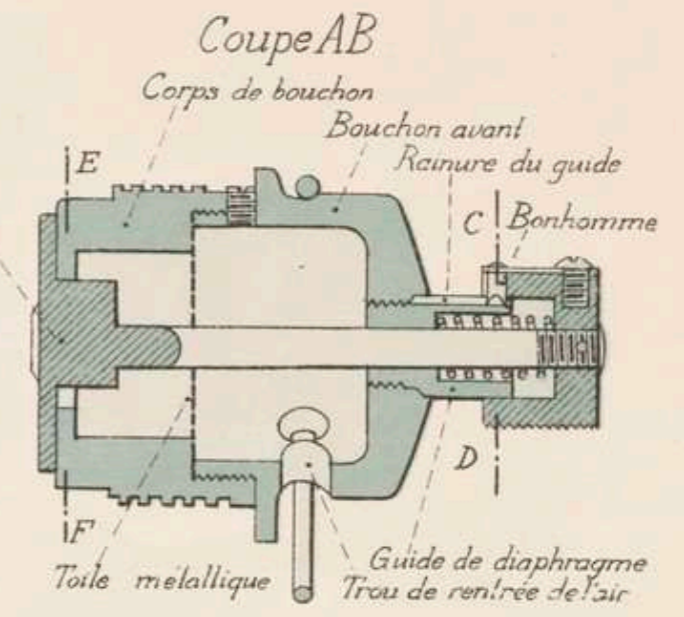
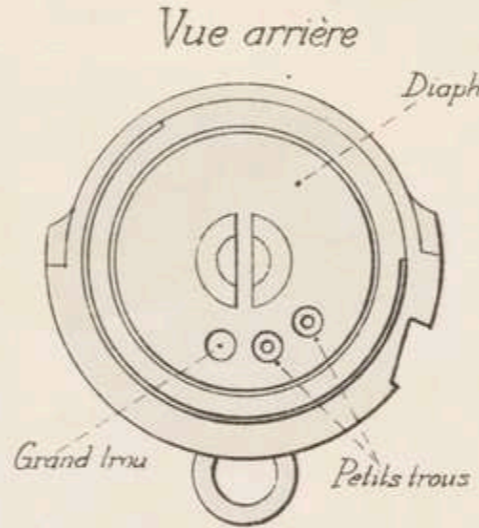
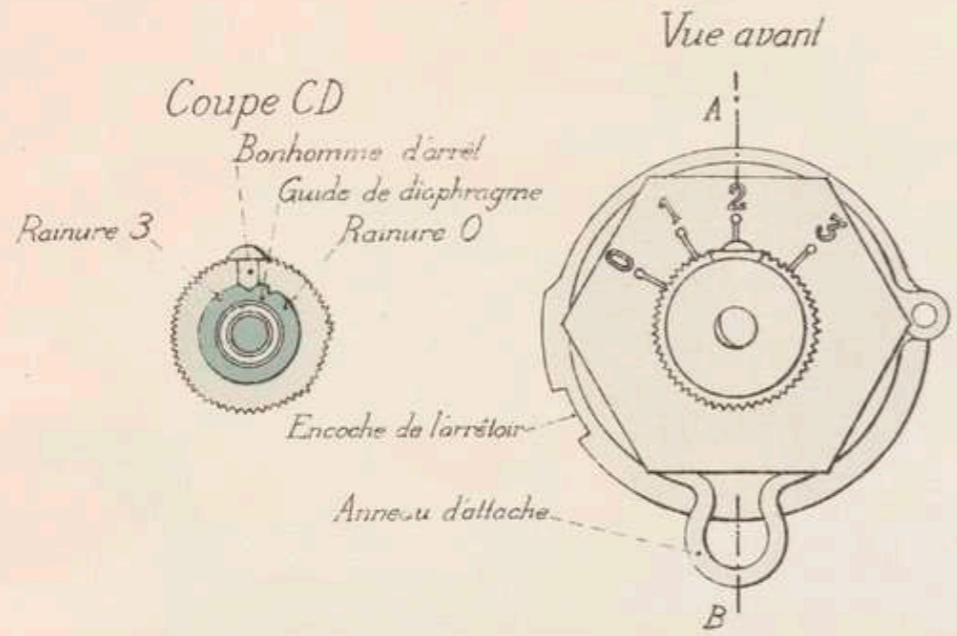

Raccord du tourillon droit

Planche XIII

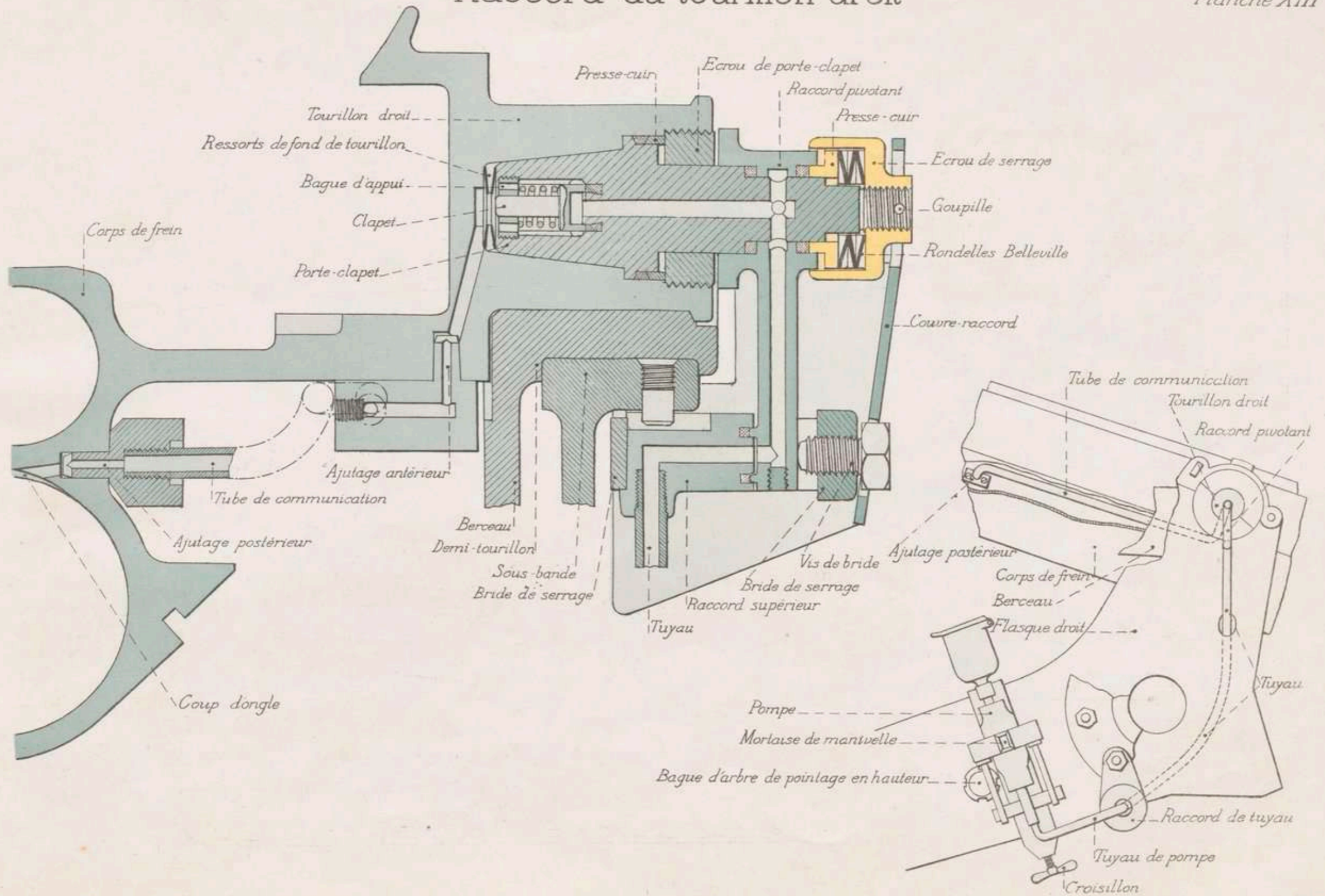

Berceau de pointage

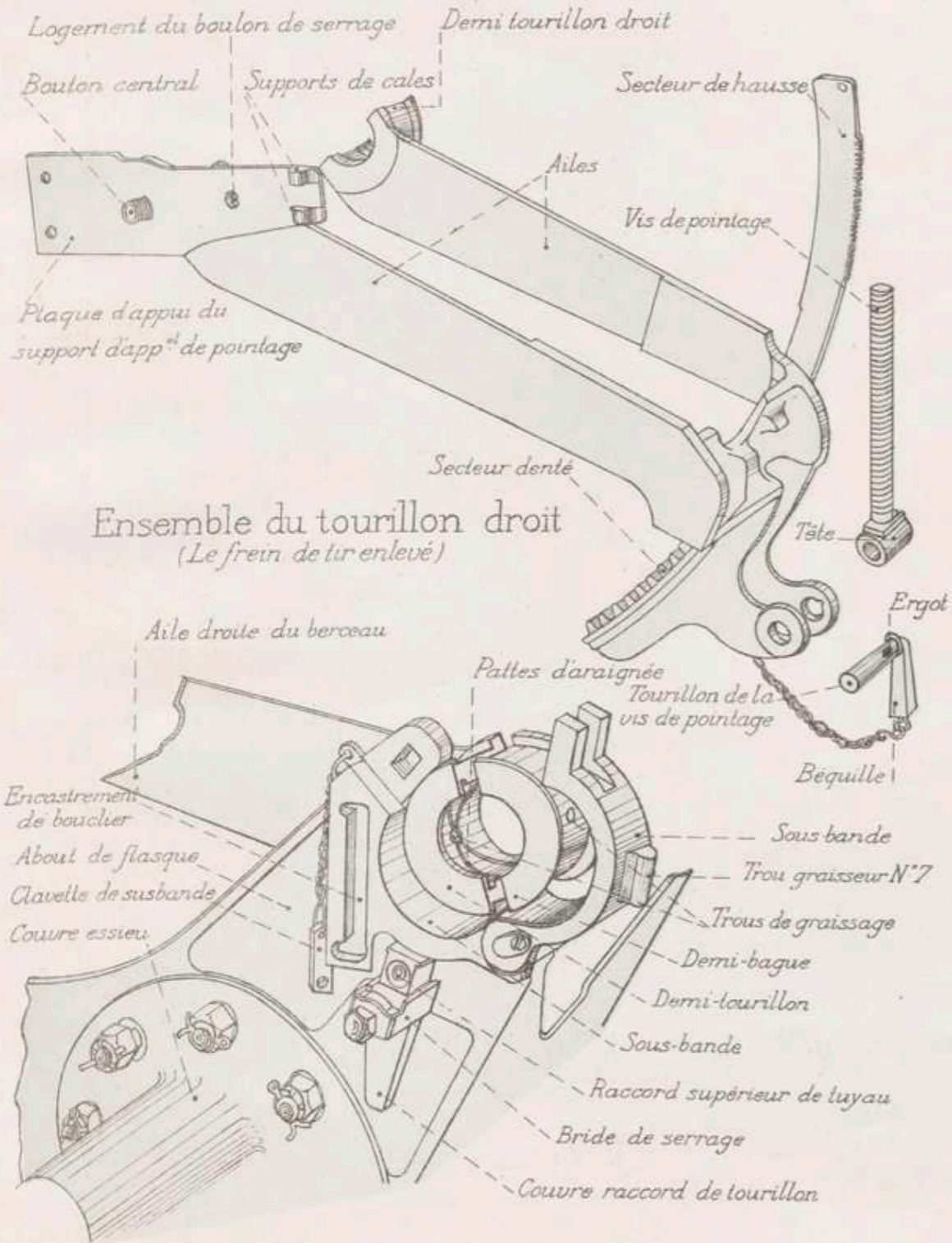

Commande de hausse

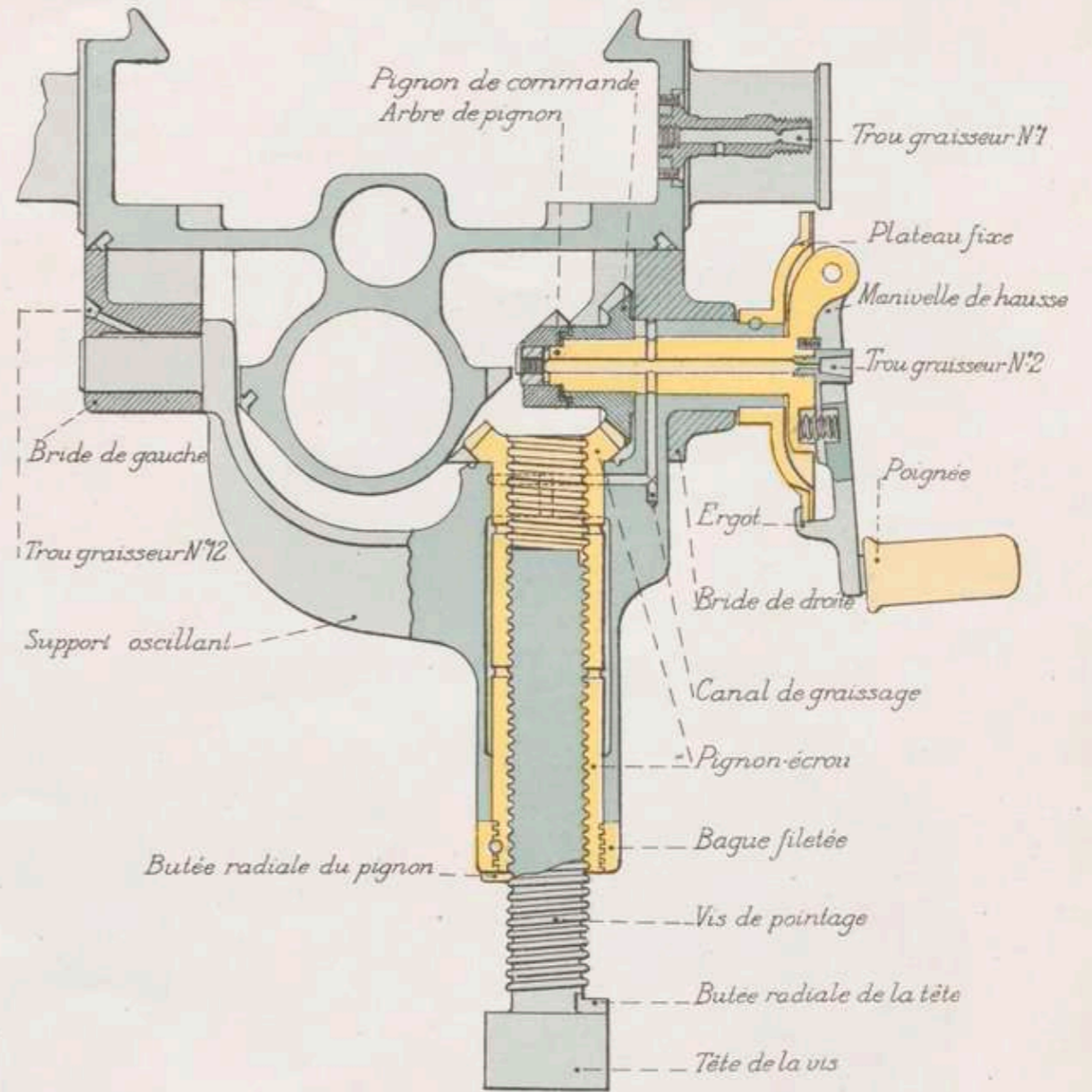

Tambour de hausse

Planche XV

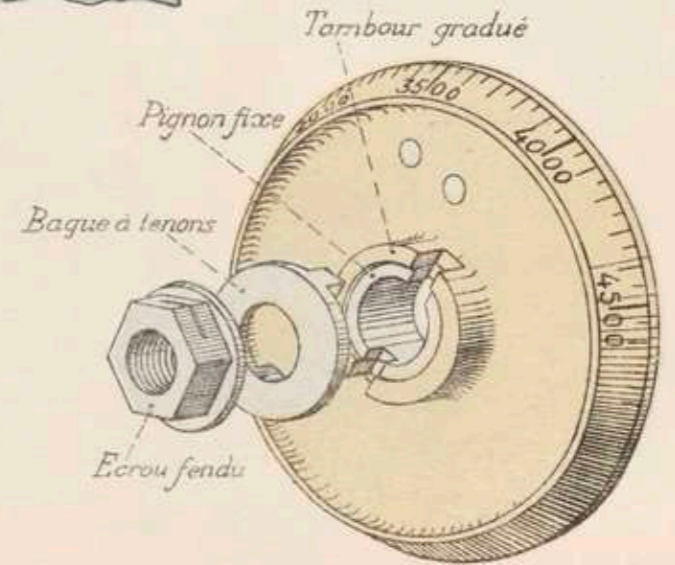
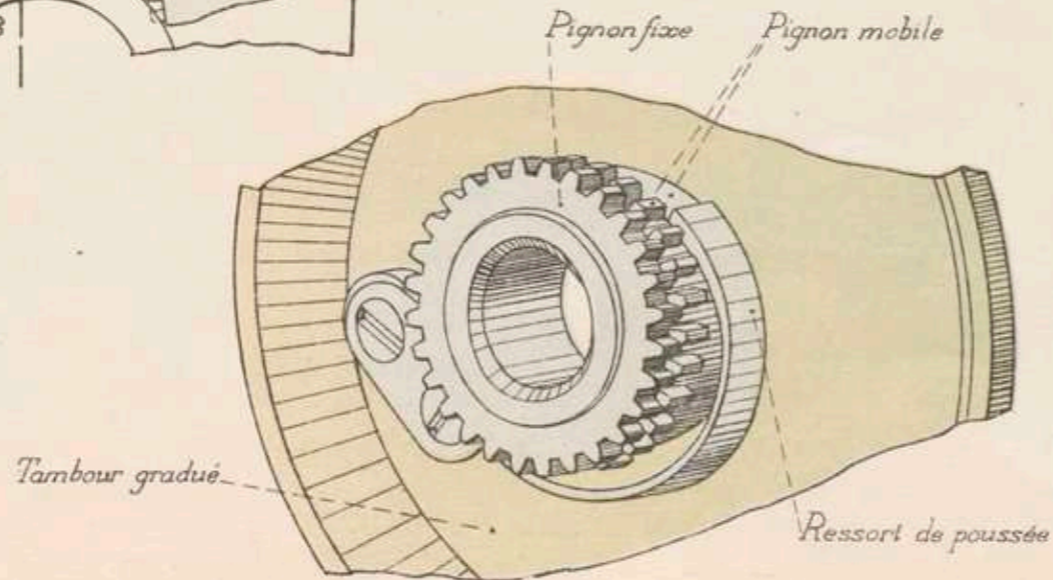
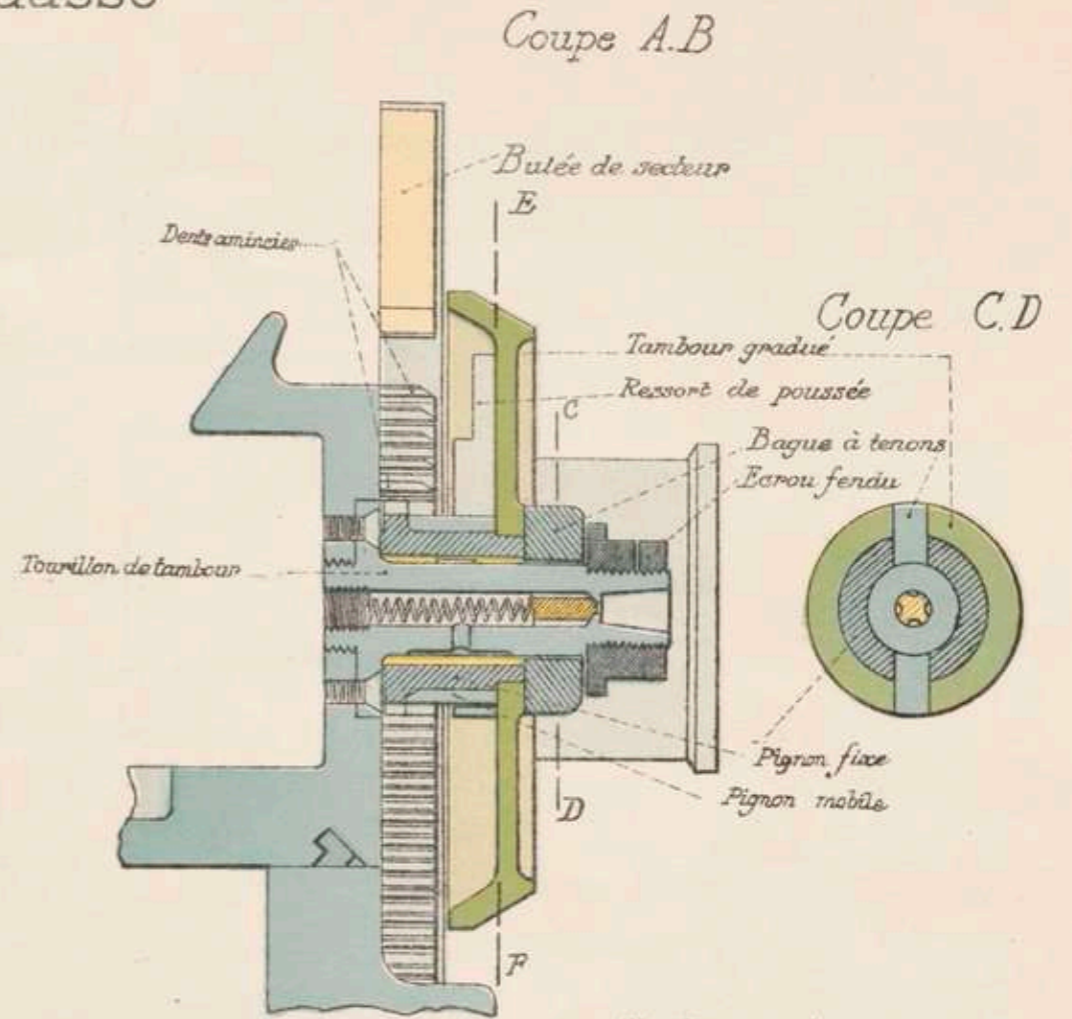
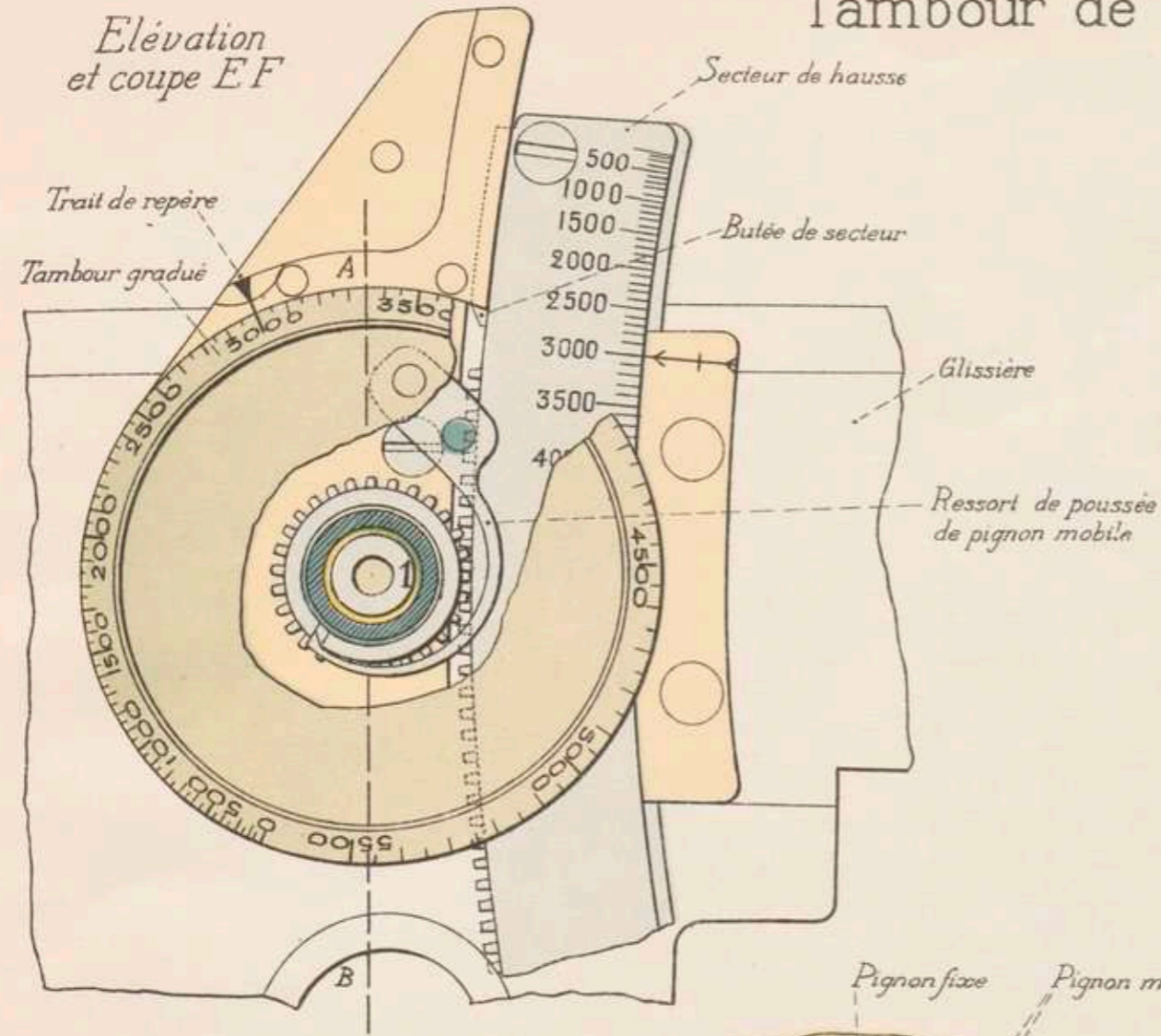

Appareil de pointage

Planche XVI

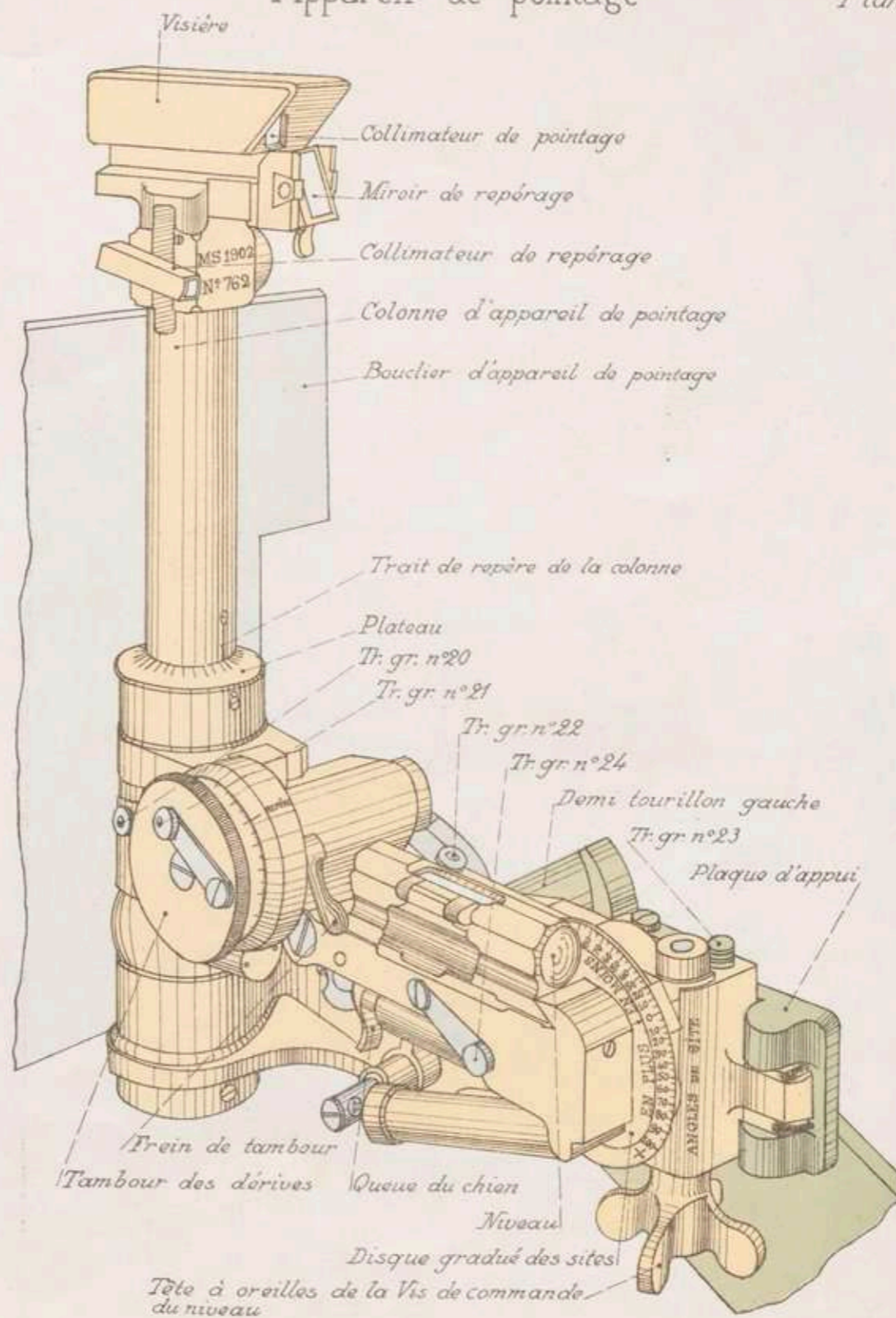

Support de pointage

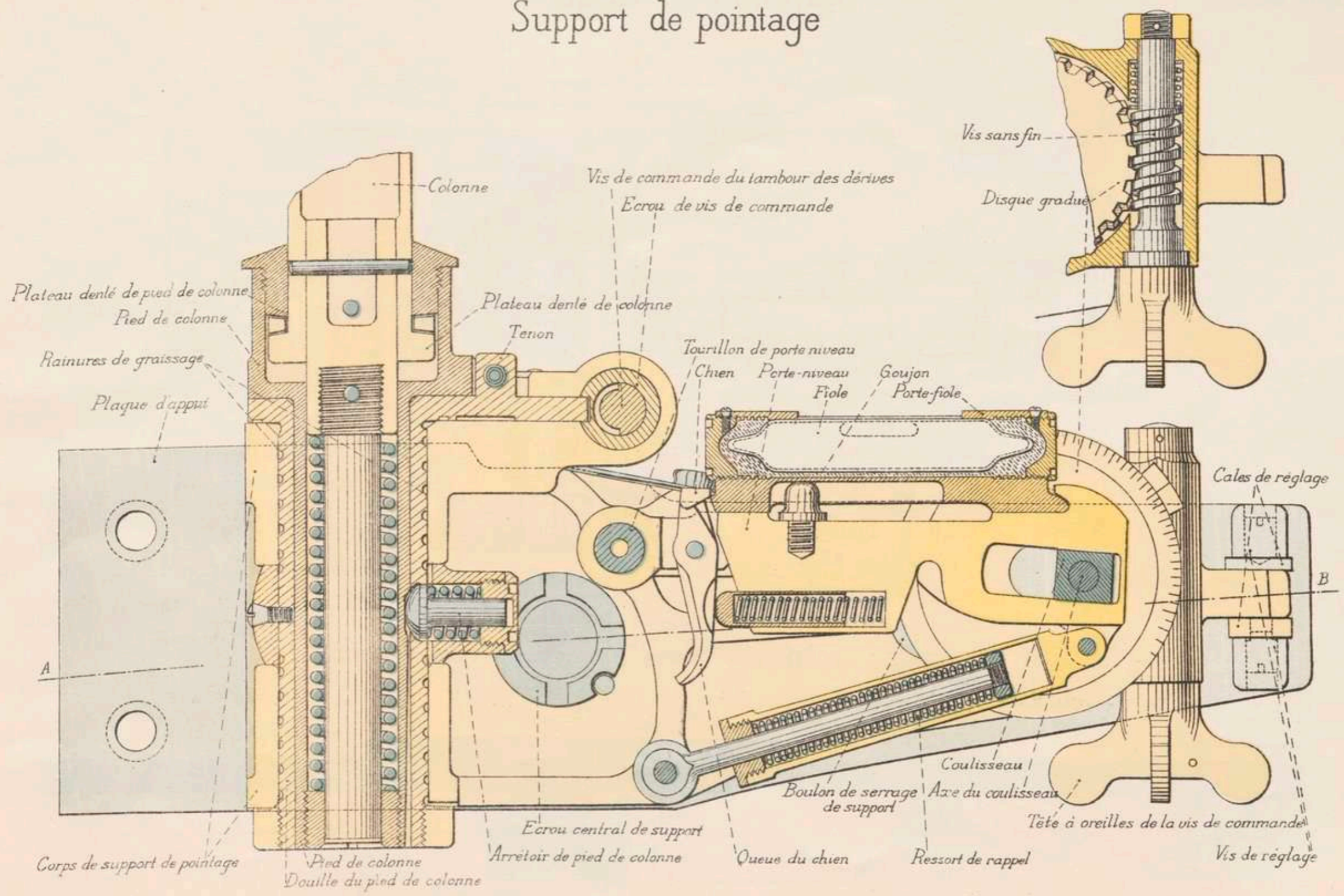

Support de pointage

Planche XVIII

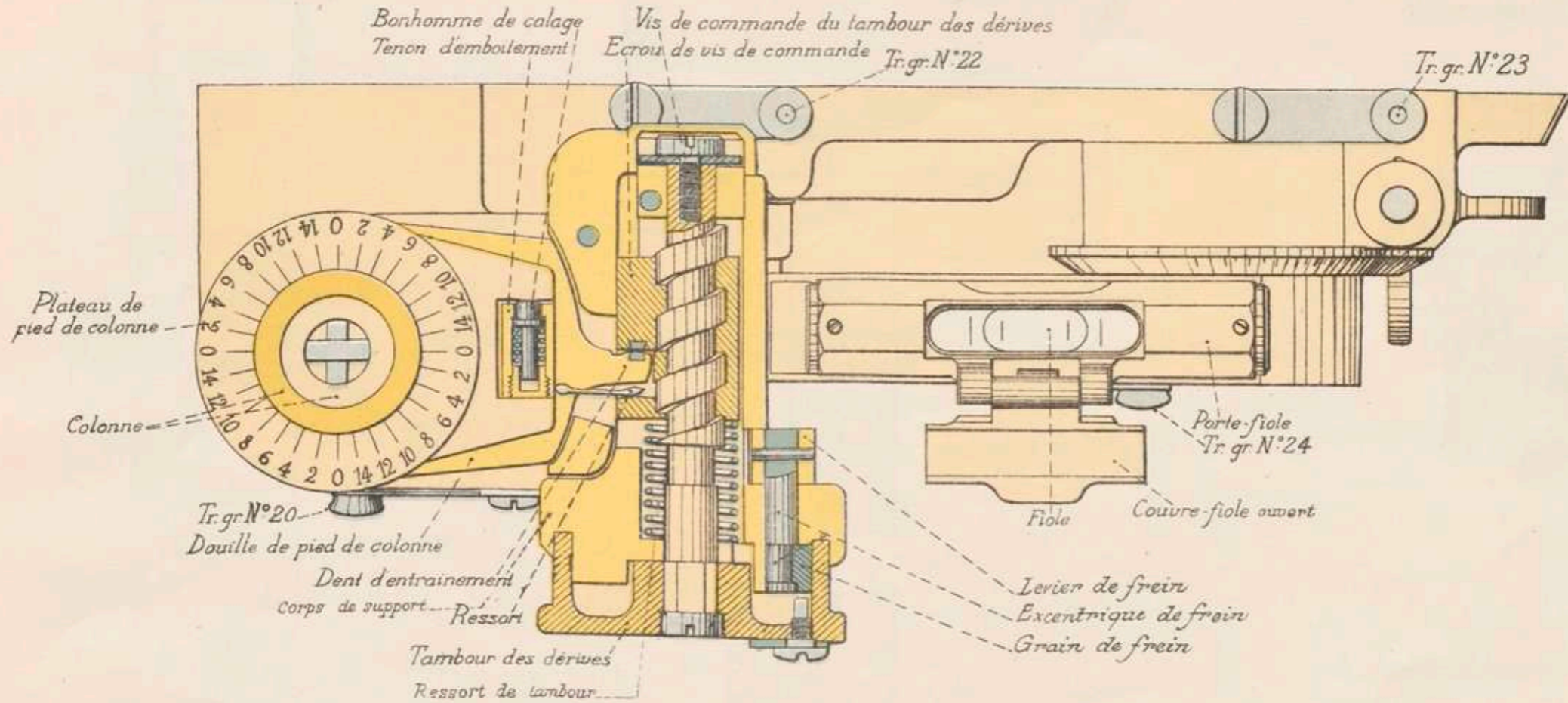

Fixation sur le berceau (Coupe AB - pl. XVII)

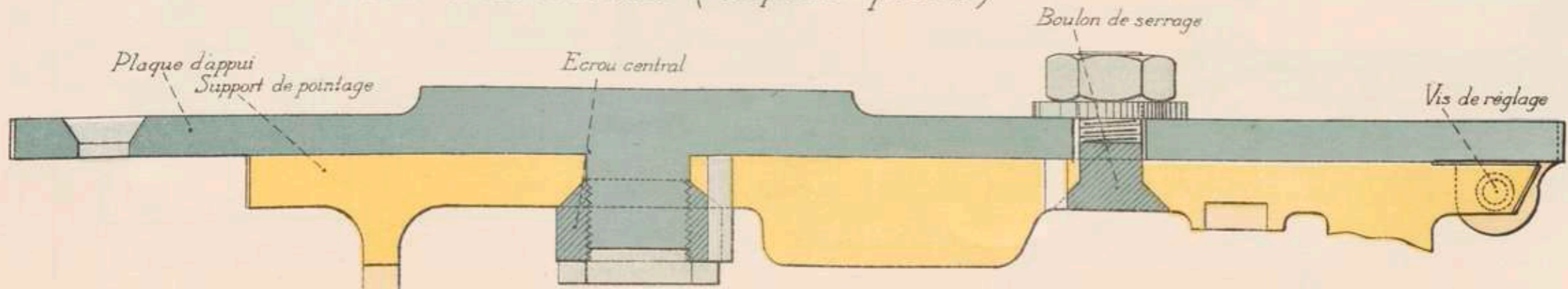

Appareil de pointage

Planche XIX

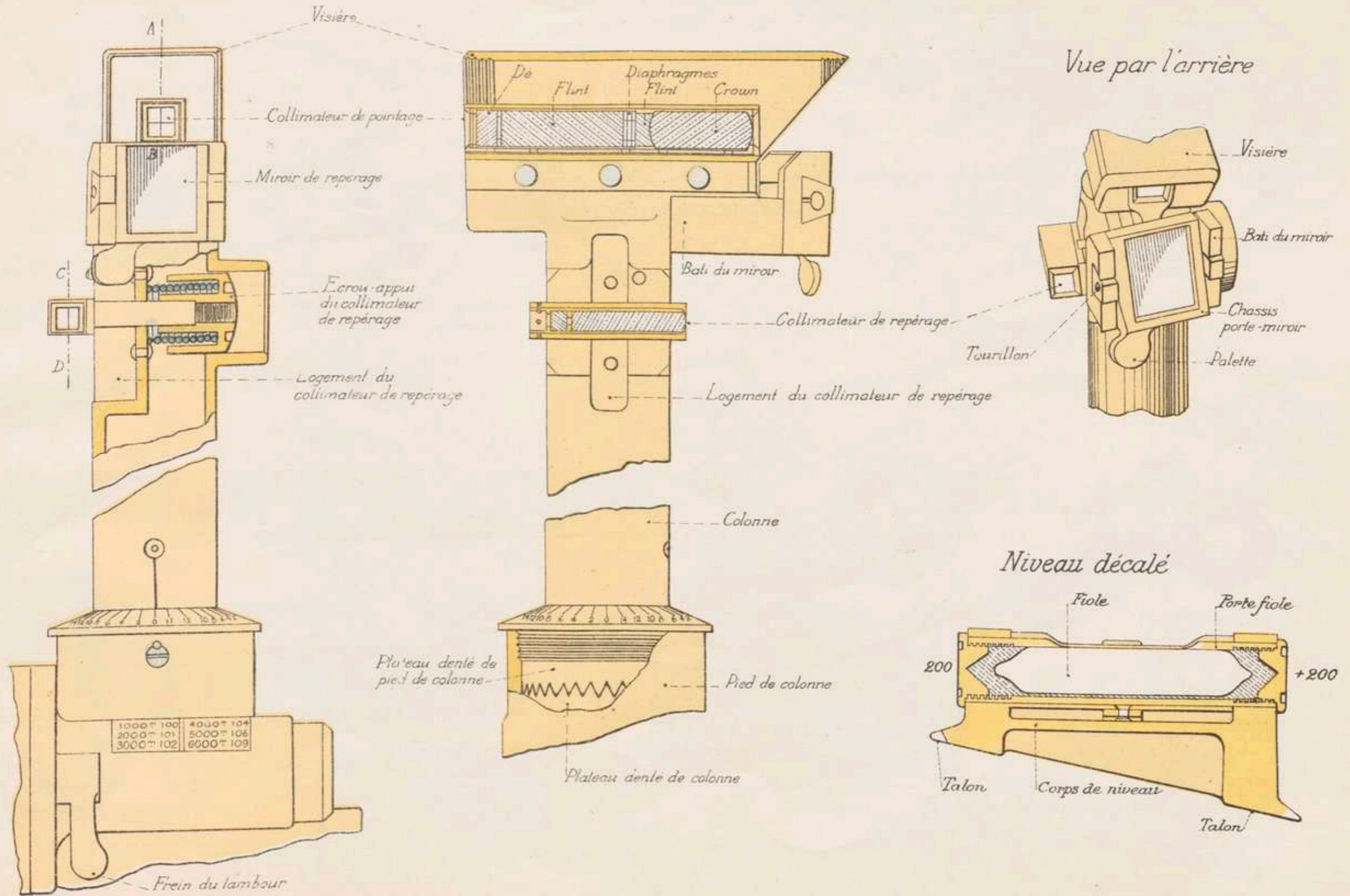

Affût

Coupe longitudinale

Planche XX

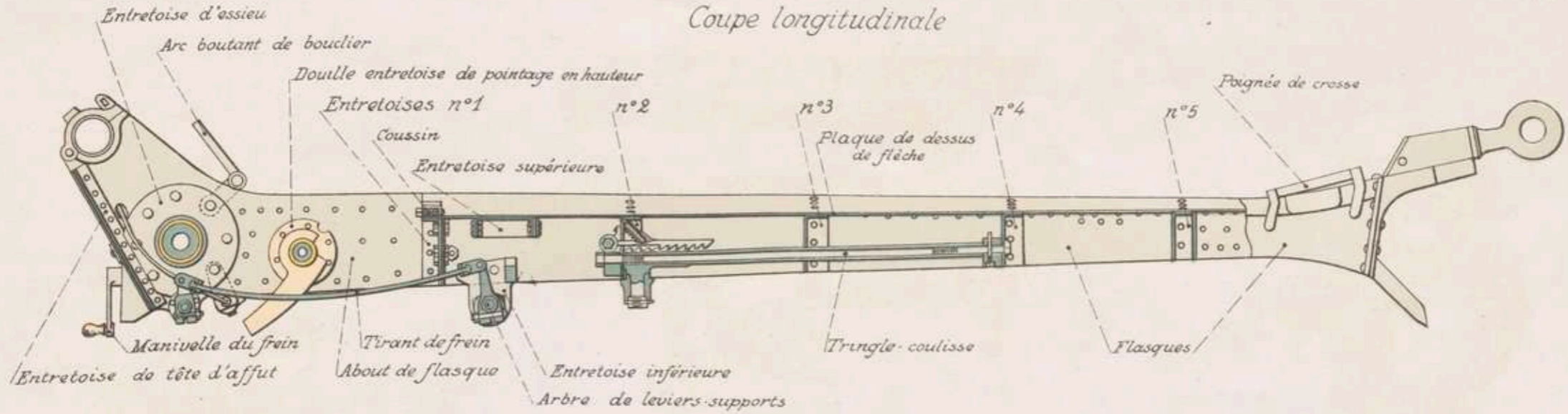

Flasque et about de flasque

Flasque (gauche)

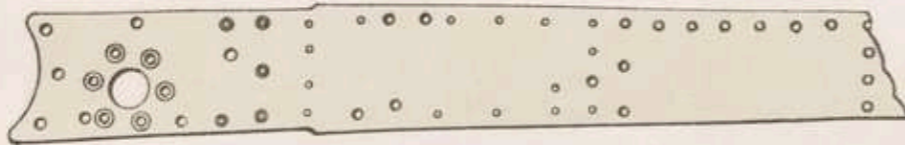

About de flasque

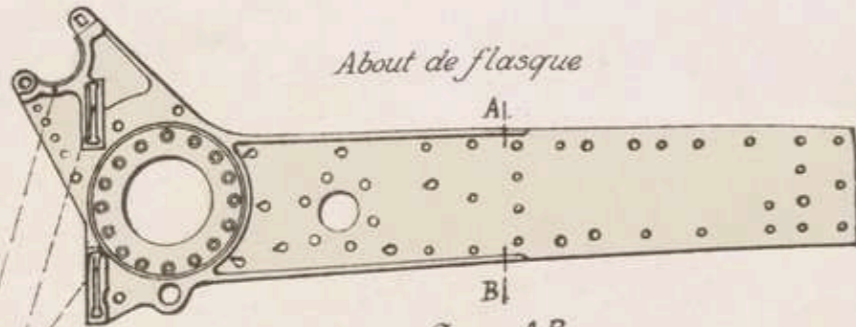

Encastrament du bouclier
Sous-bande



Lunette et bêche de crosse

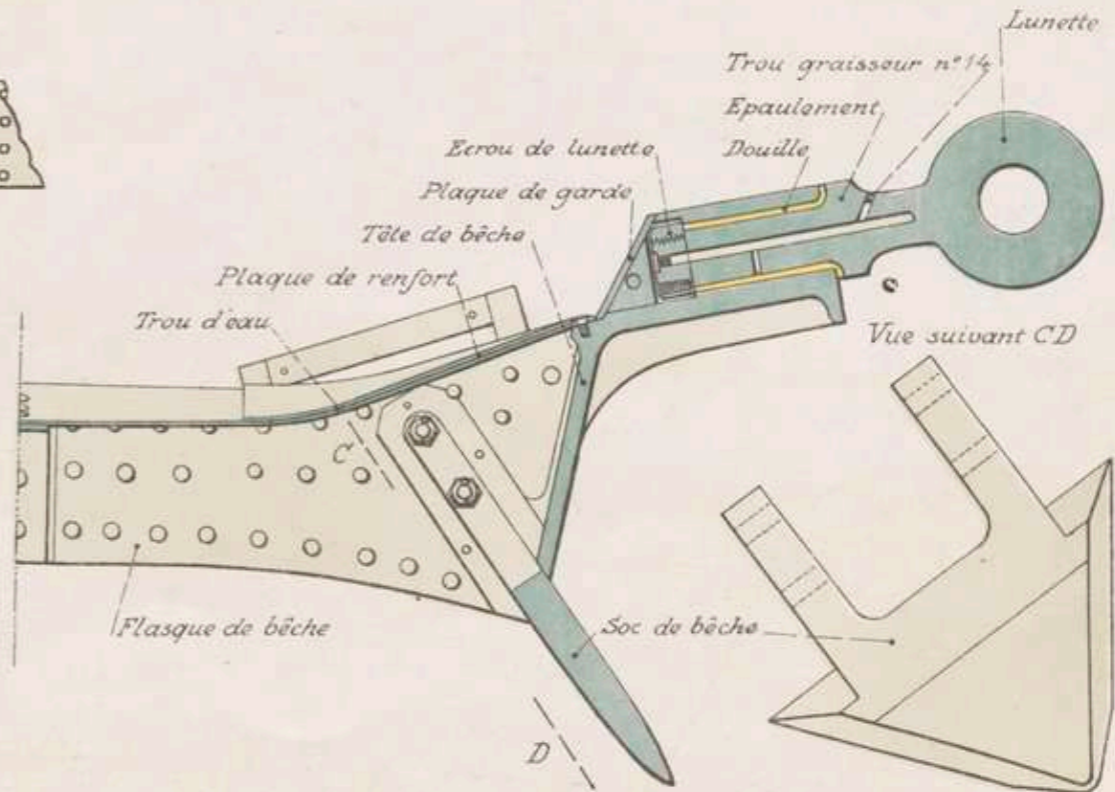

Commandes de pointage

Planche XXI

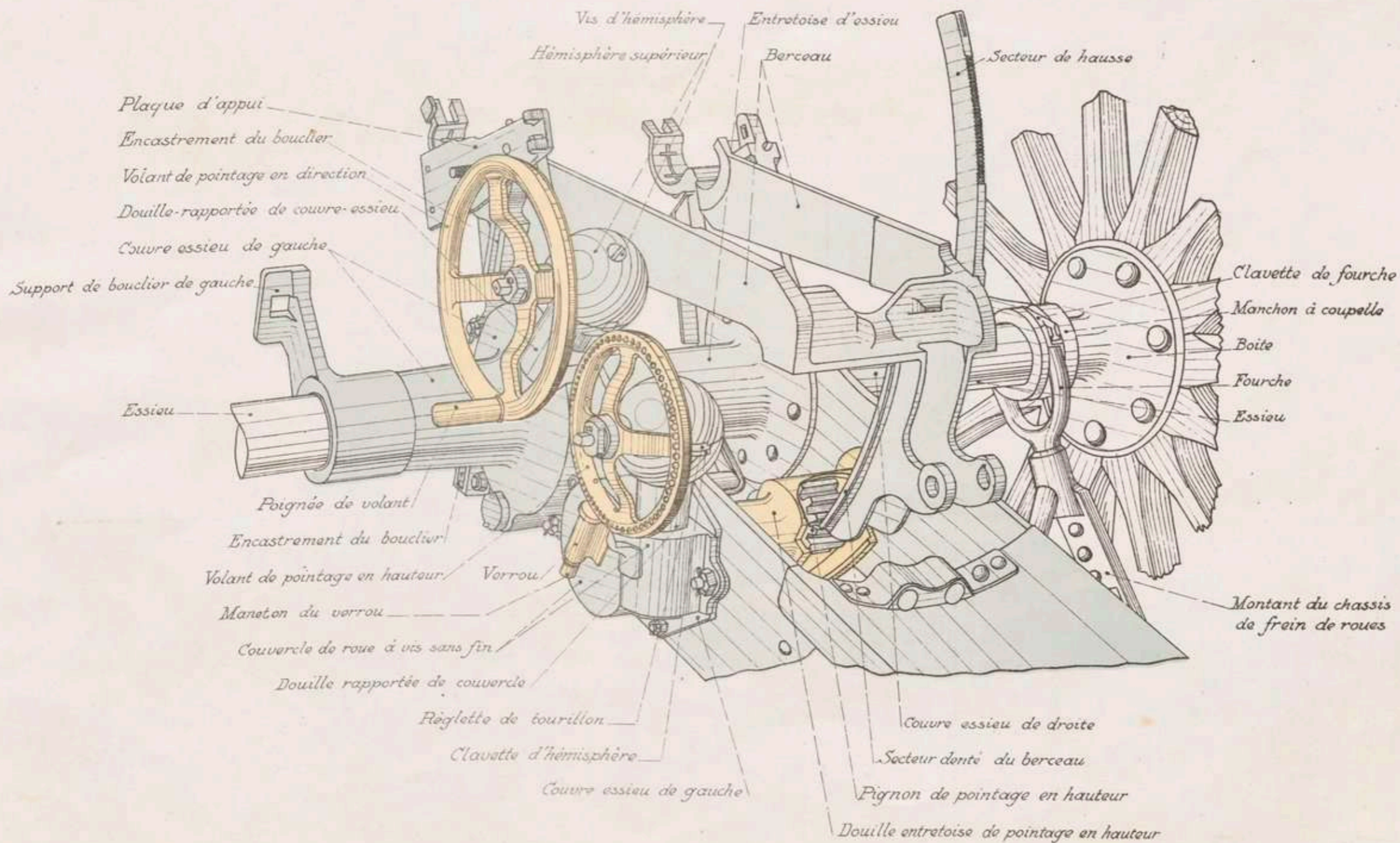

Systeme de pointage en hauteur

Planche XXII

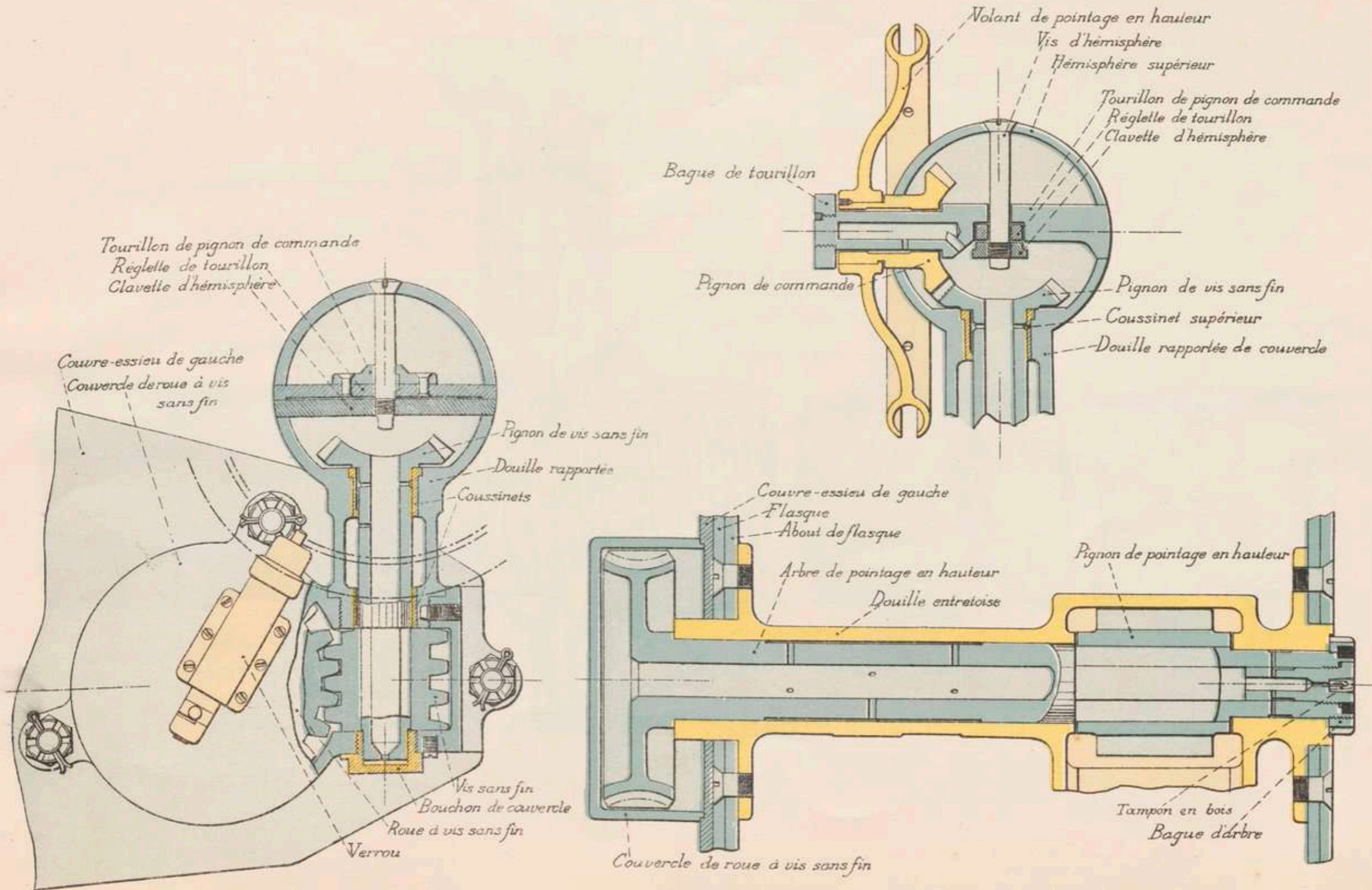

Systeme de pointage en direction

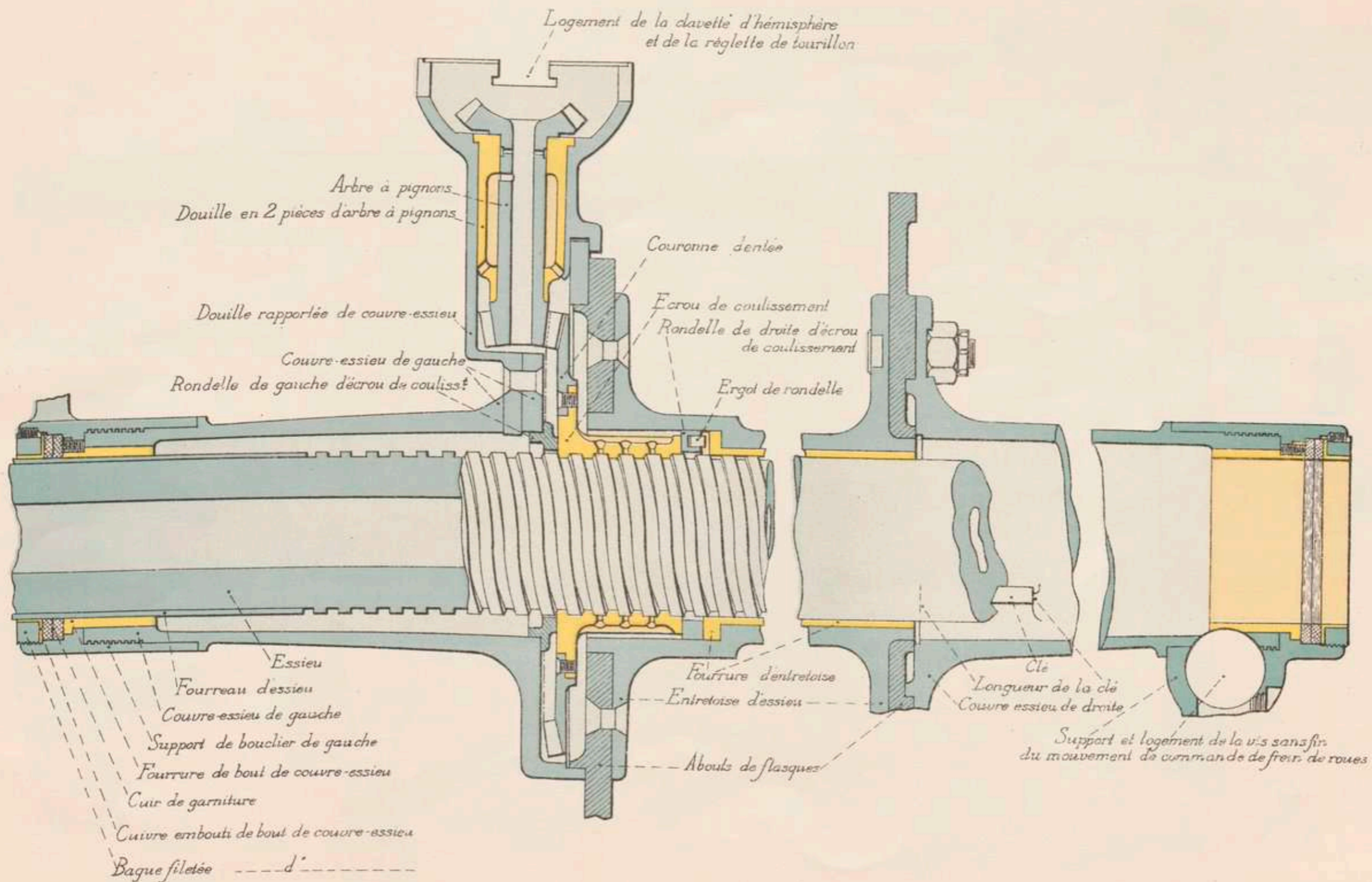

Essieu et Roue renforcée

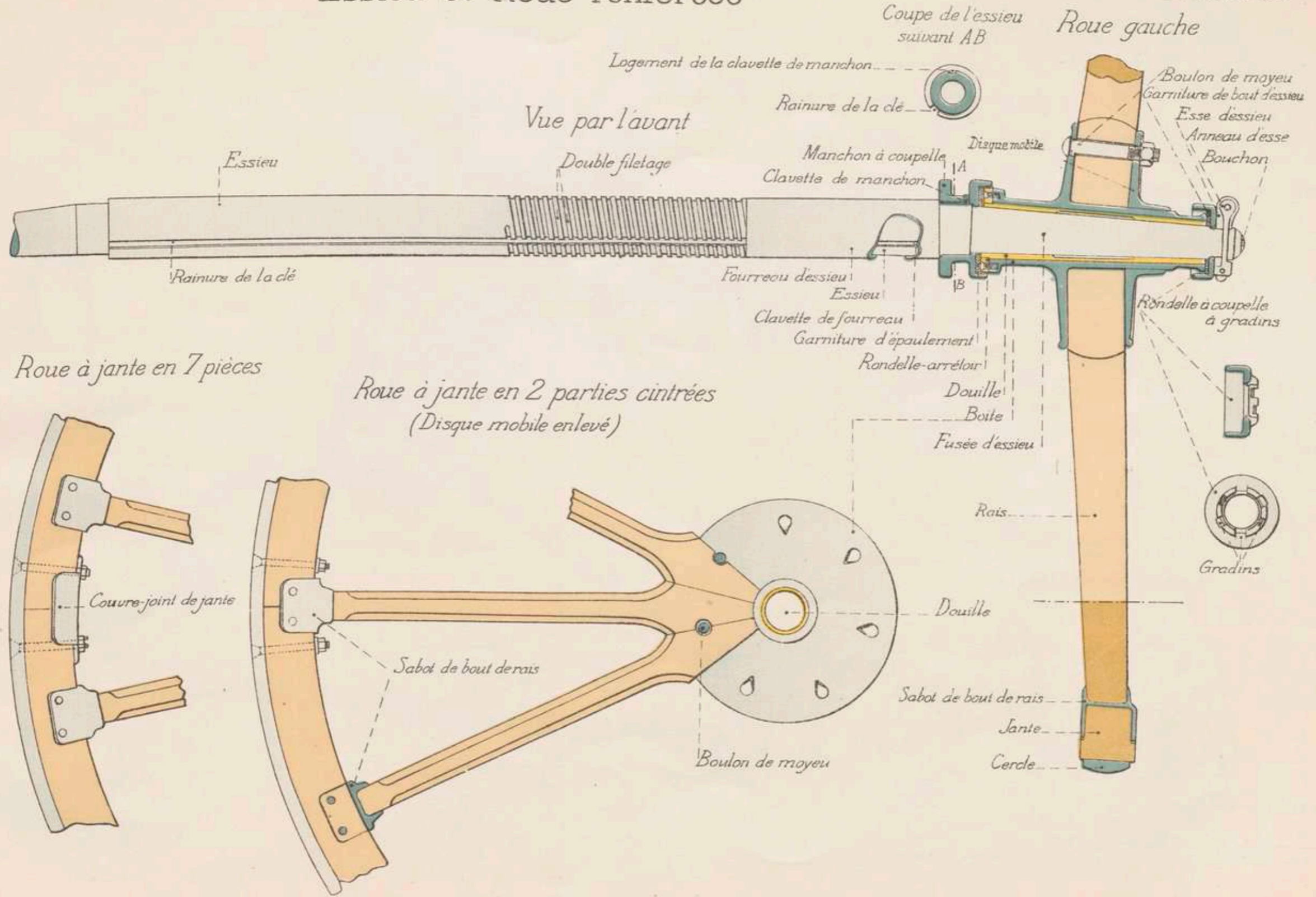

Frein de roues

Planche XXV

Guidage du châssis - Coupe longitudinale

Châssis

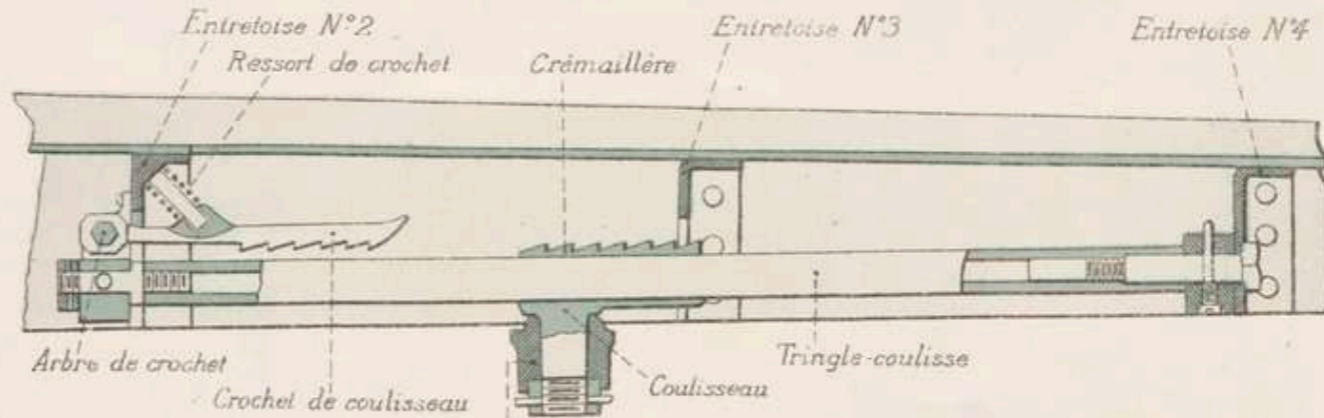
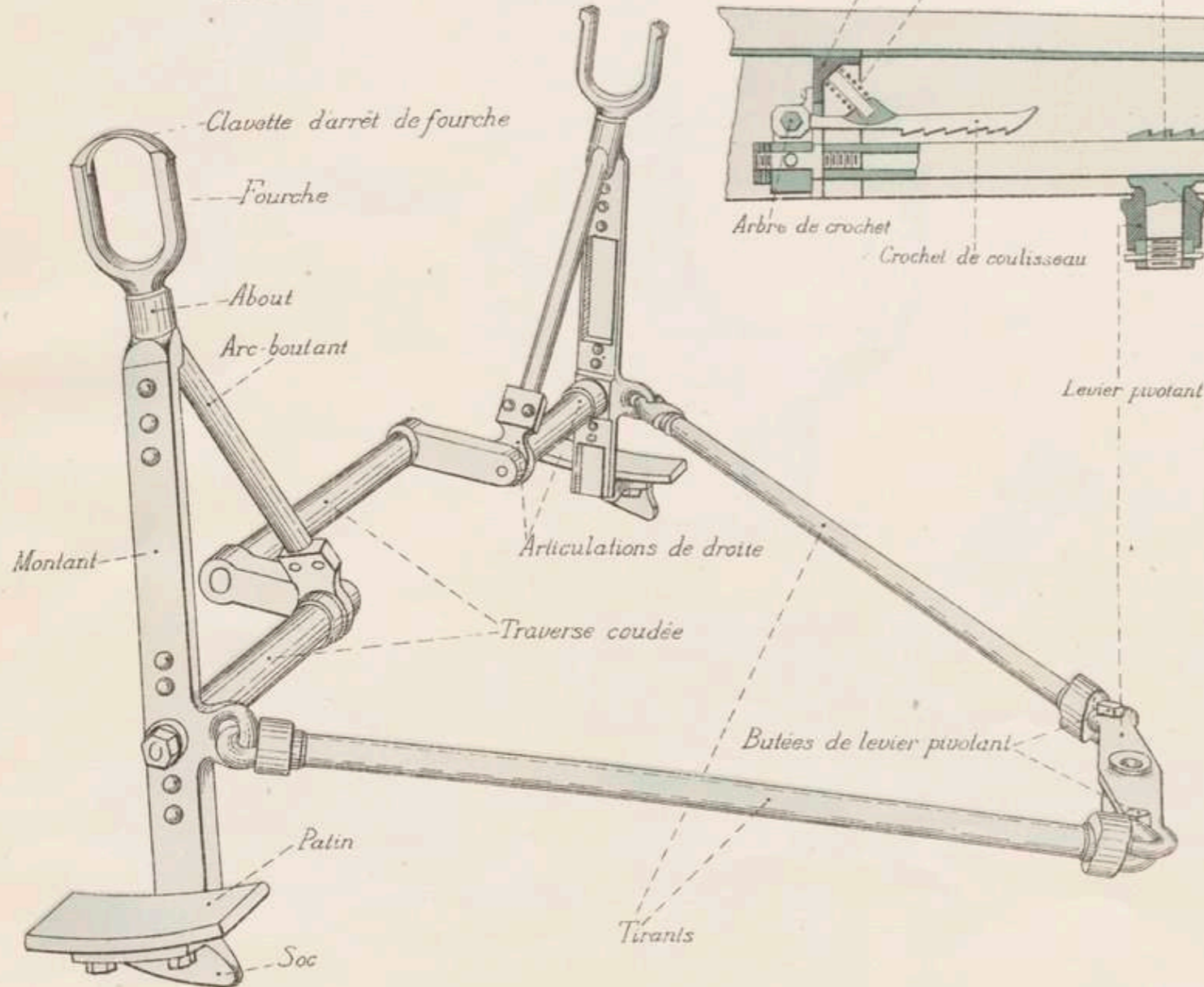

Vue par la droite de l'affut

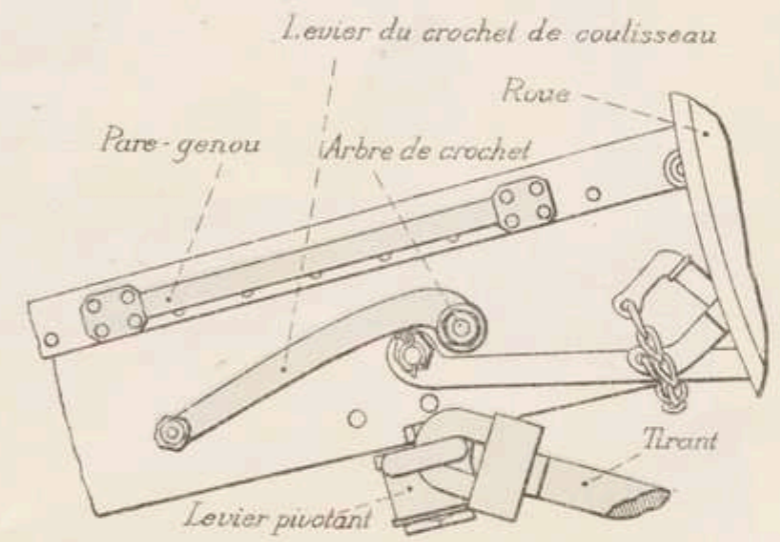

Articulations du châssis

Planche XXVI

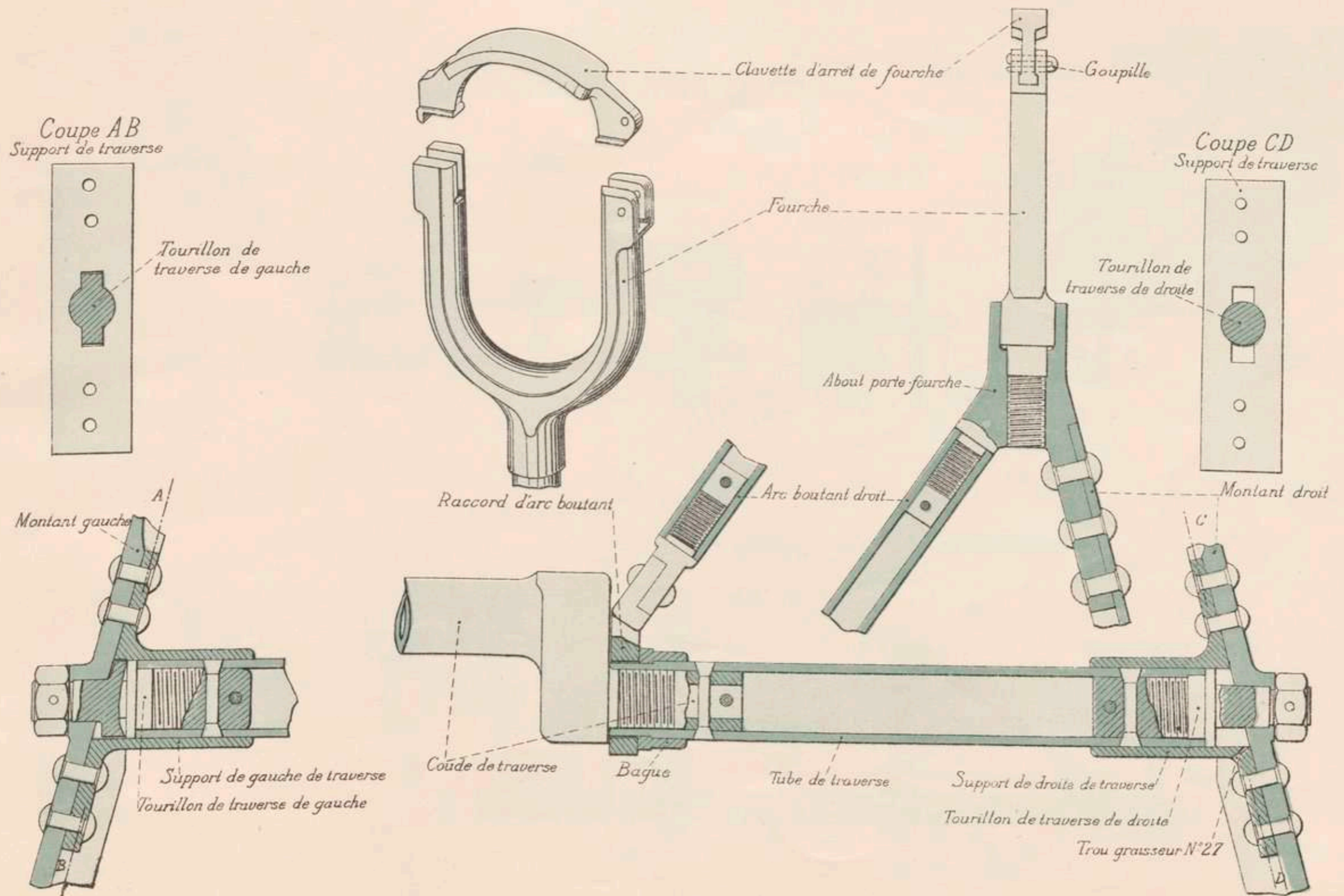

Accrochage du châssis - Commande du frein de roues

Planche XXVII

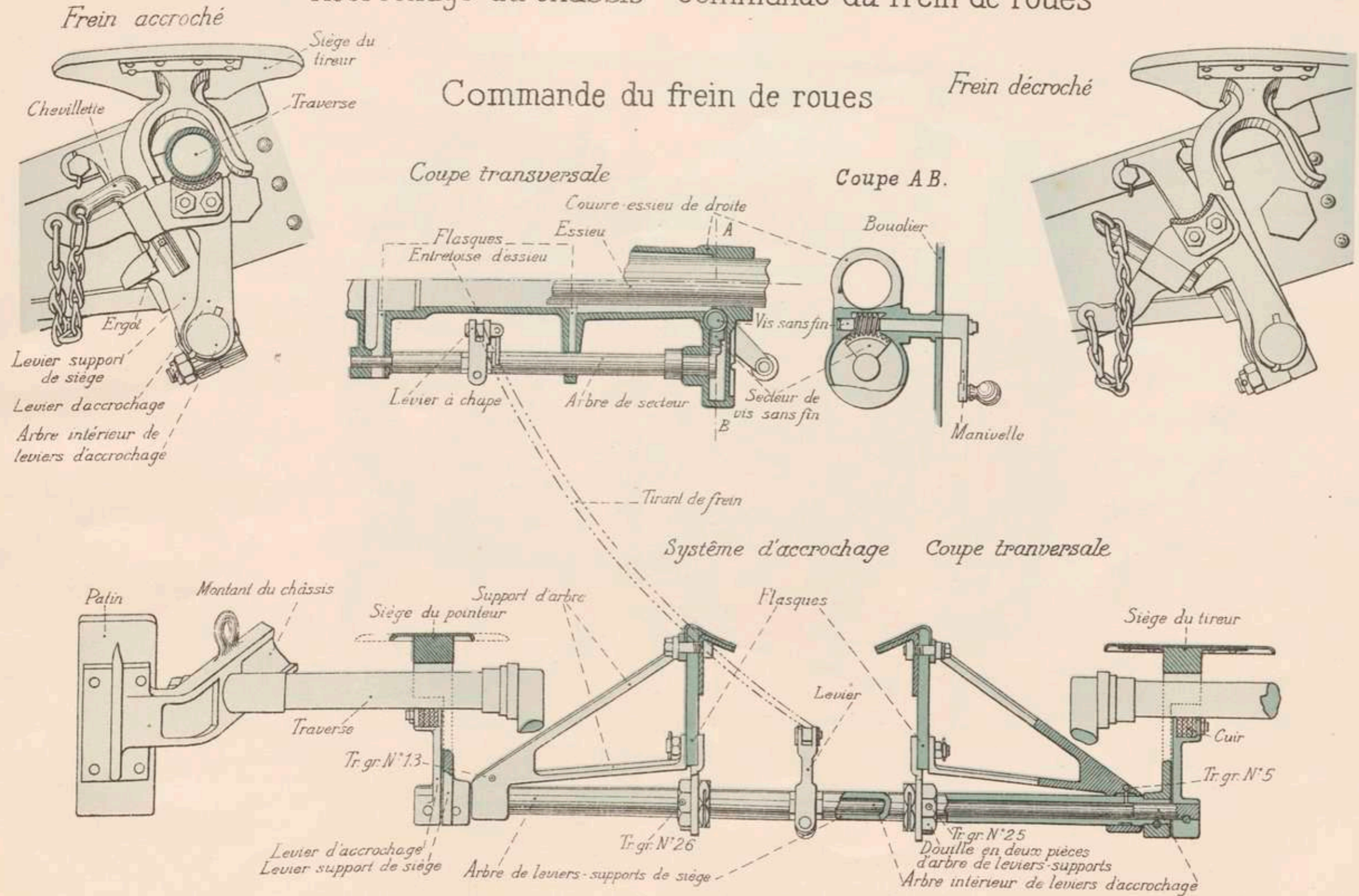

Avant-train (Le couvercle du coffre enlevé)

Planche XXVIII

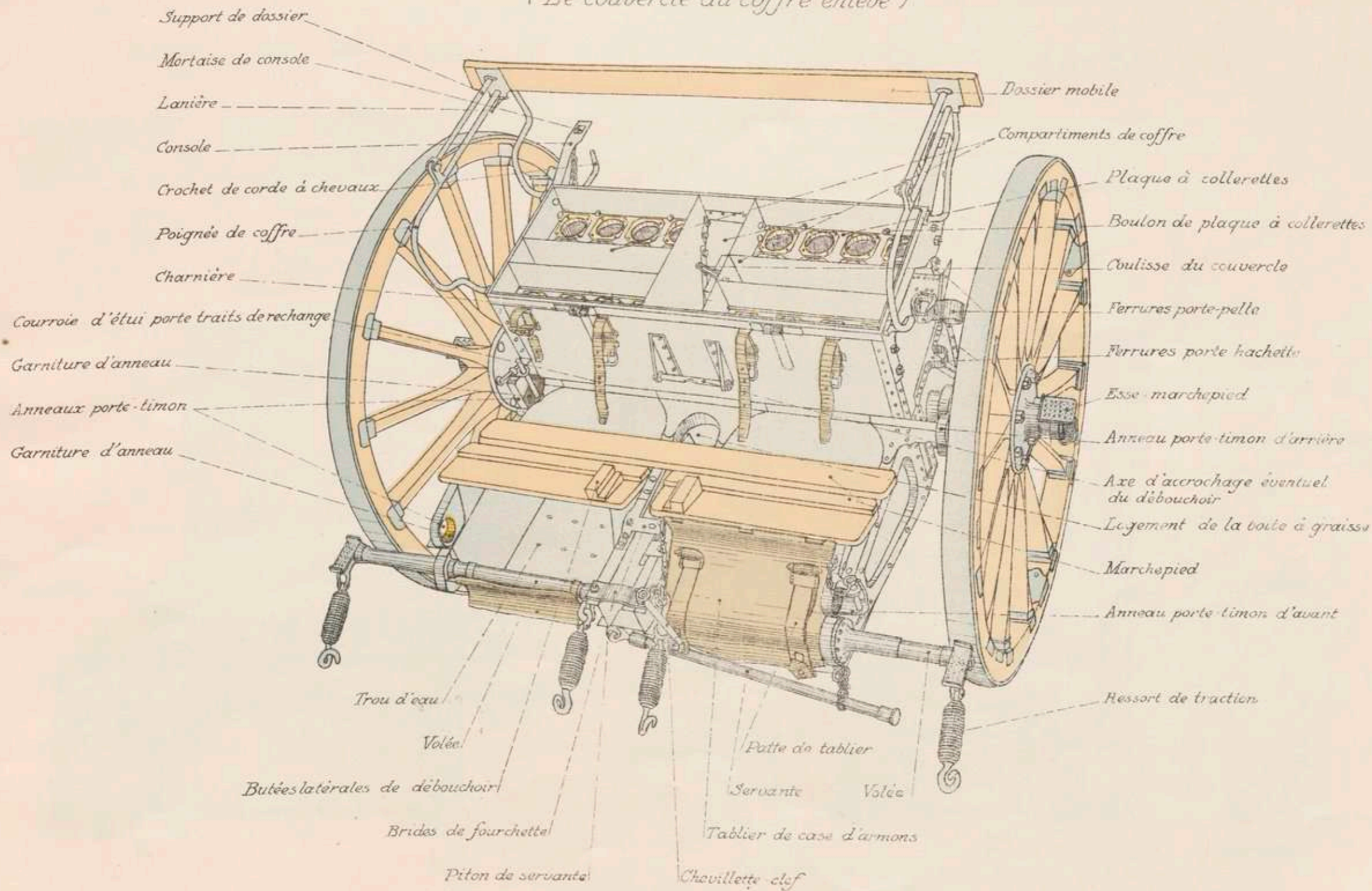

Avant-train

Planche XXIX

Elevation par l'arrière et coupe A-B

Coupe C-D Coupe E-F

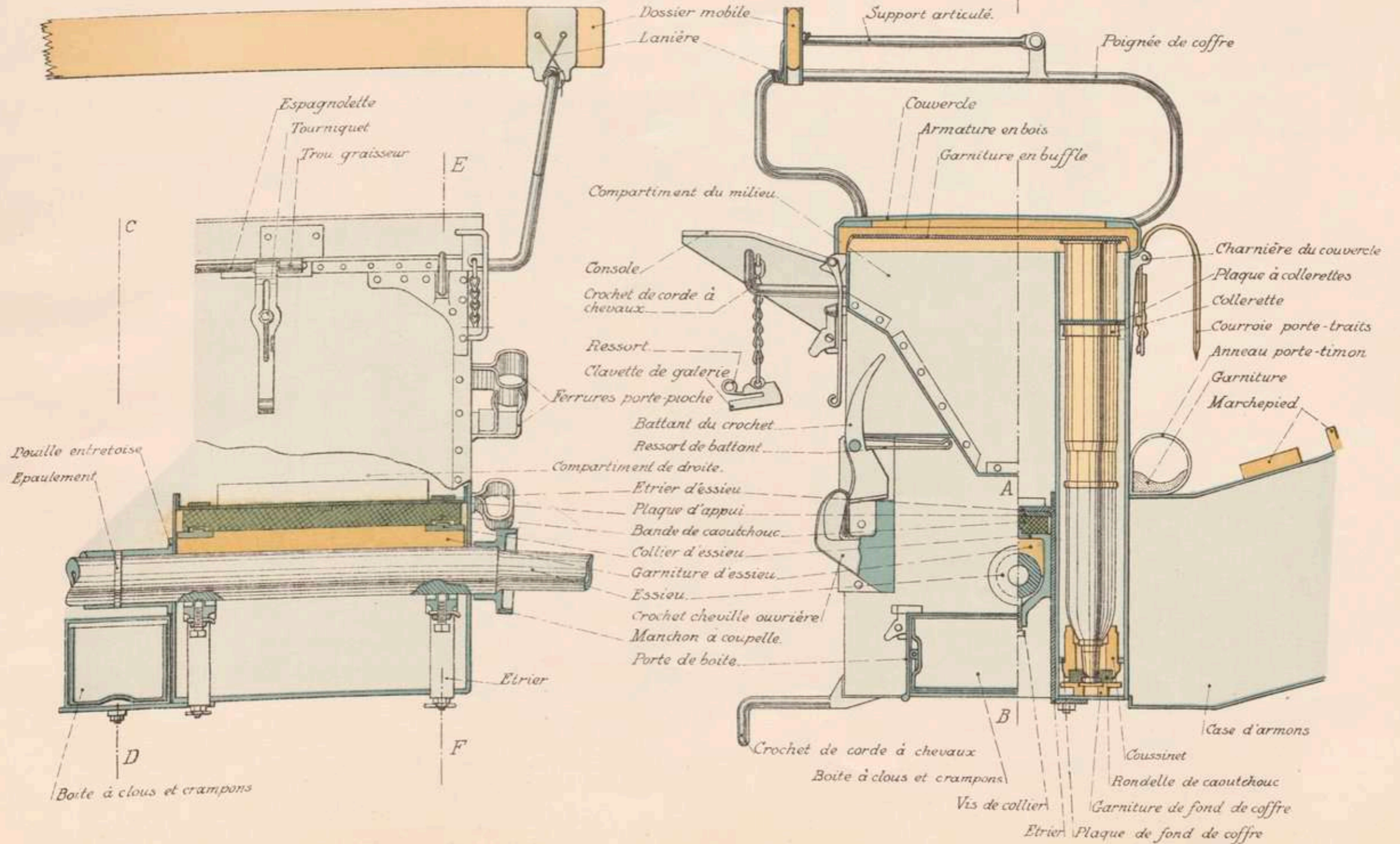

Arrière-train de caisson

(Le couvercle de droite enlevé)

Planche XXX

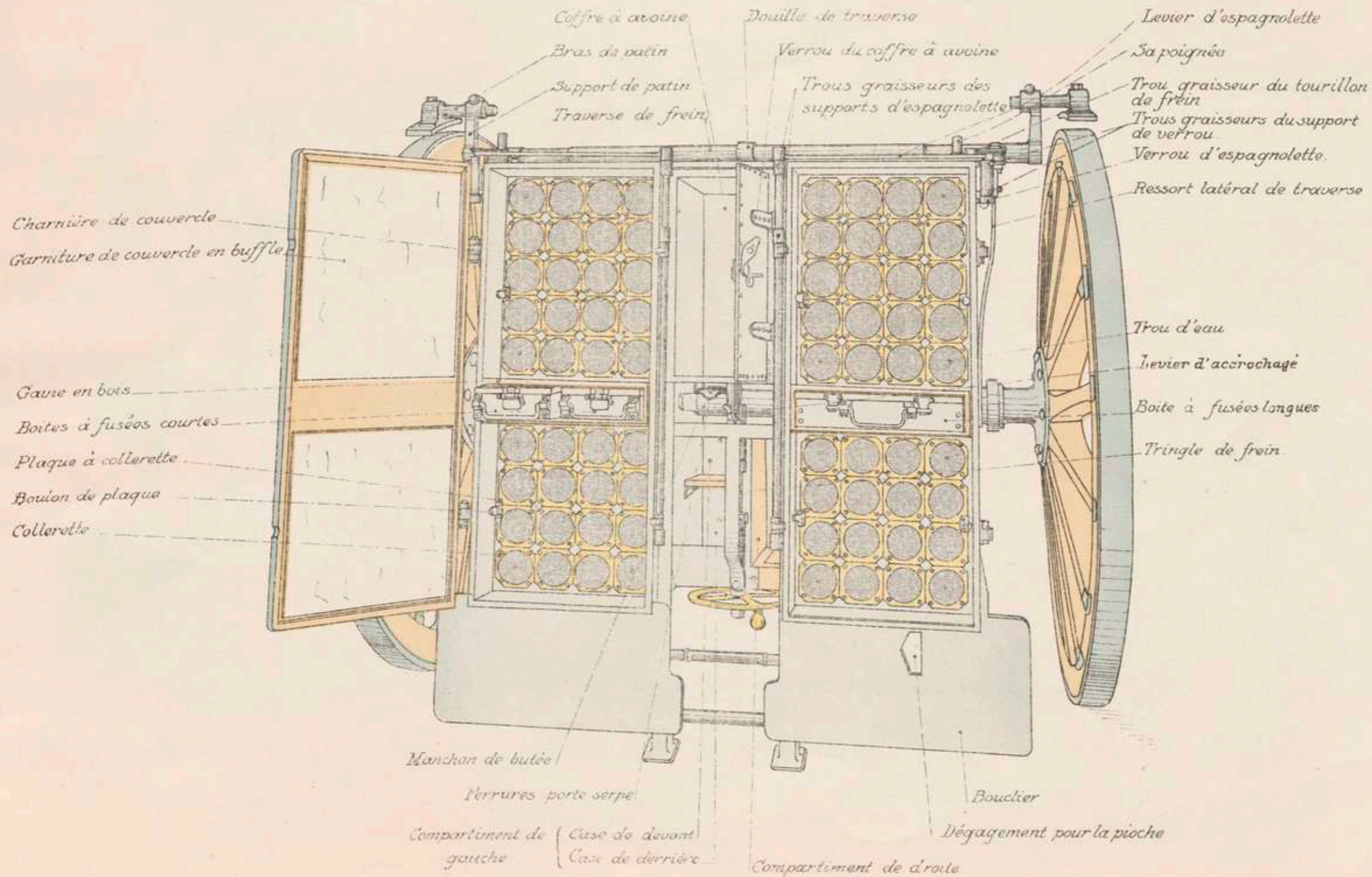

Arrière-train de Caisson

Coupe longitudinale par l'axe

Planche XXXI

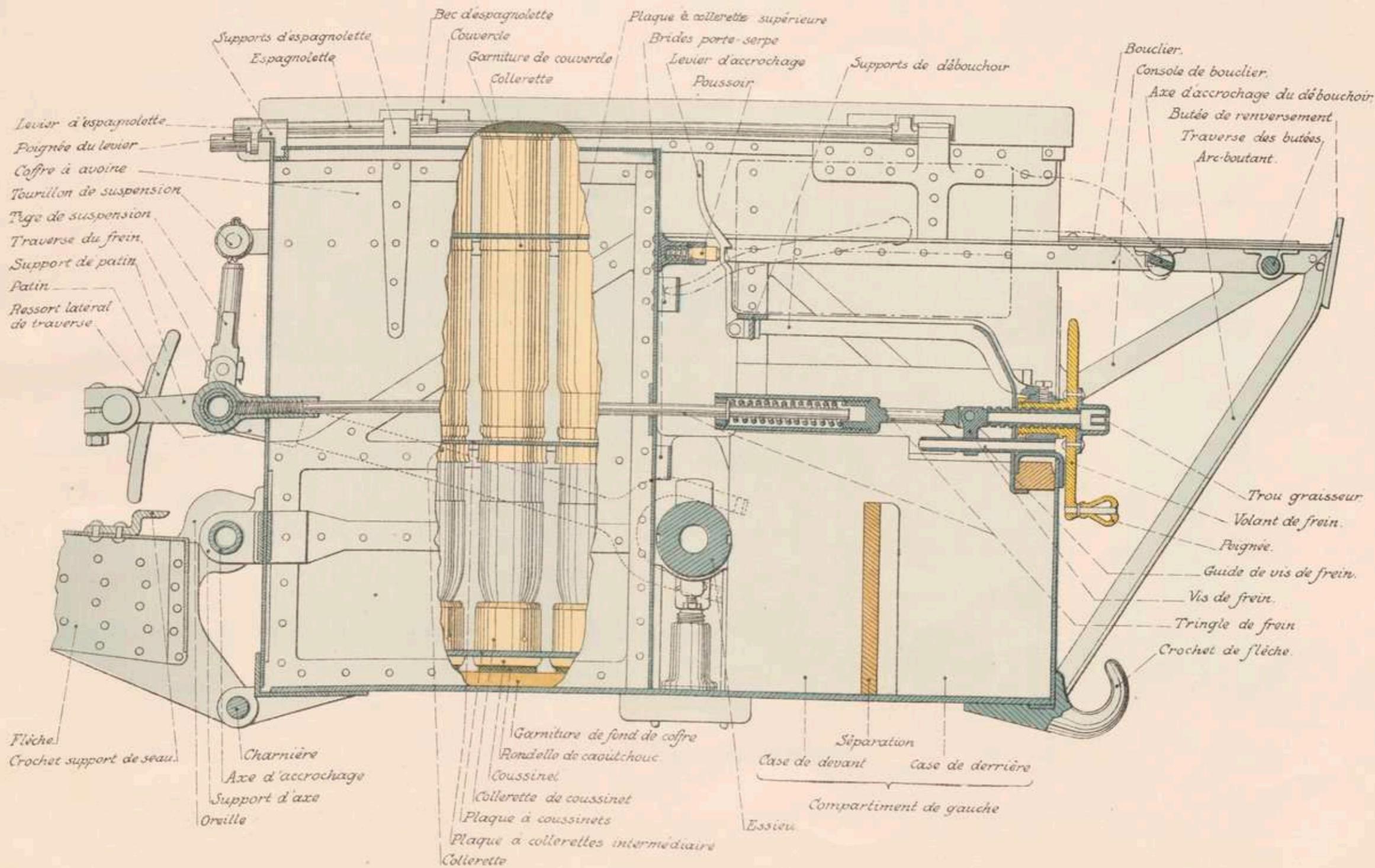

Arrière-train de caisson

Coupe par l'axe de l'essieu

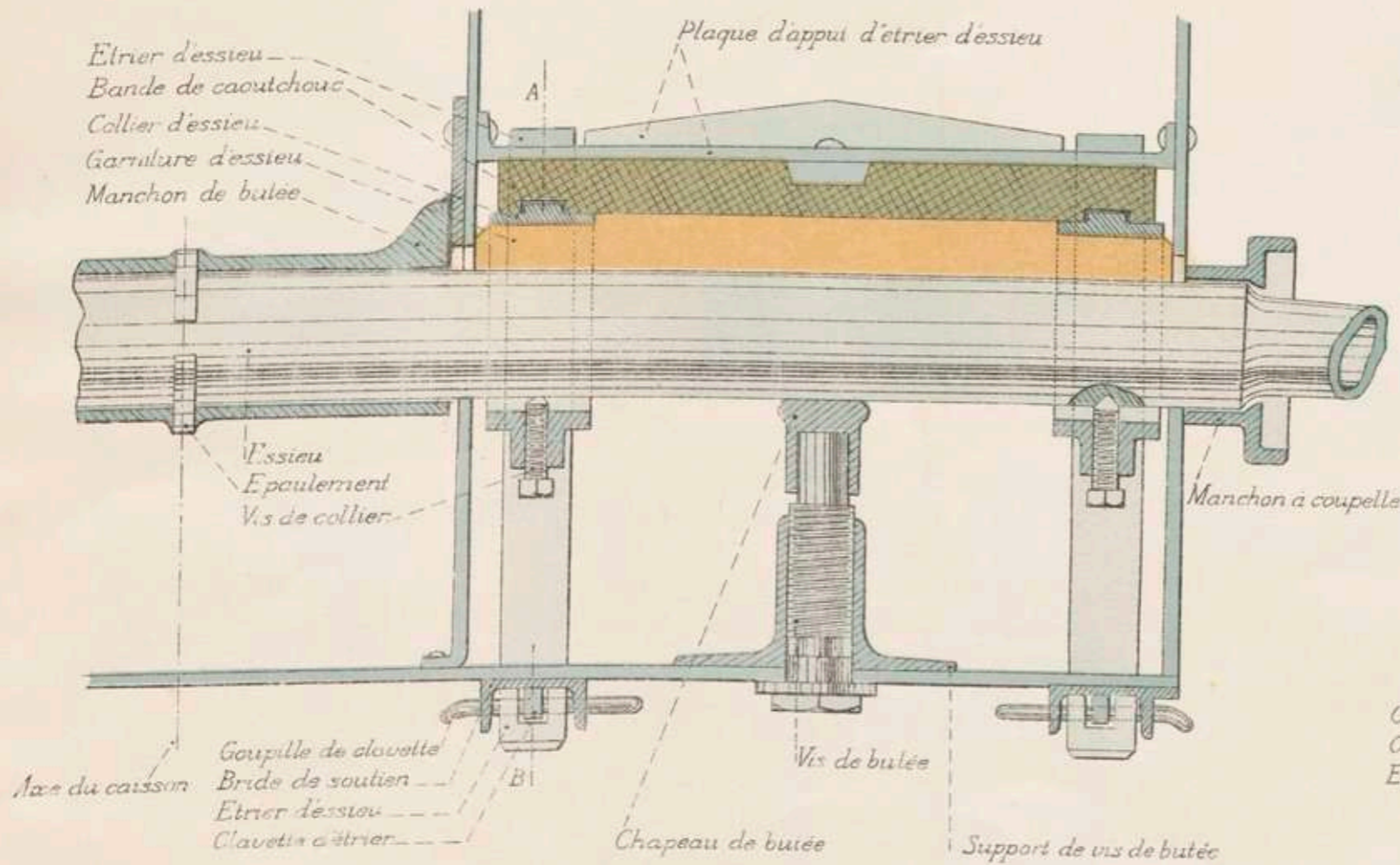

Coupe AB



Schéma des engrenages



Liaison de la boîte d'ogive et de la roue de 68 dents

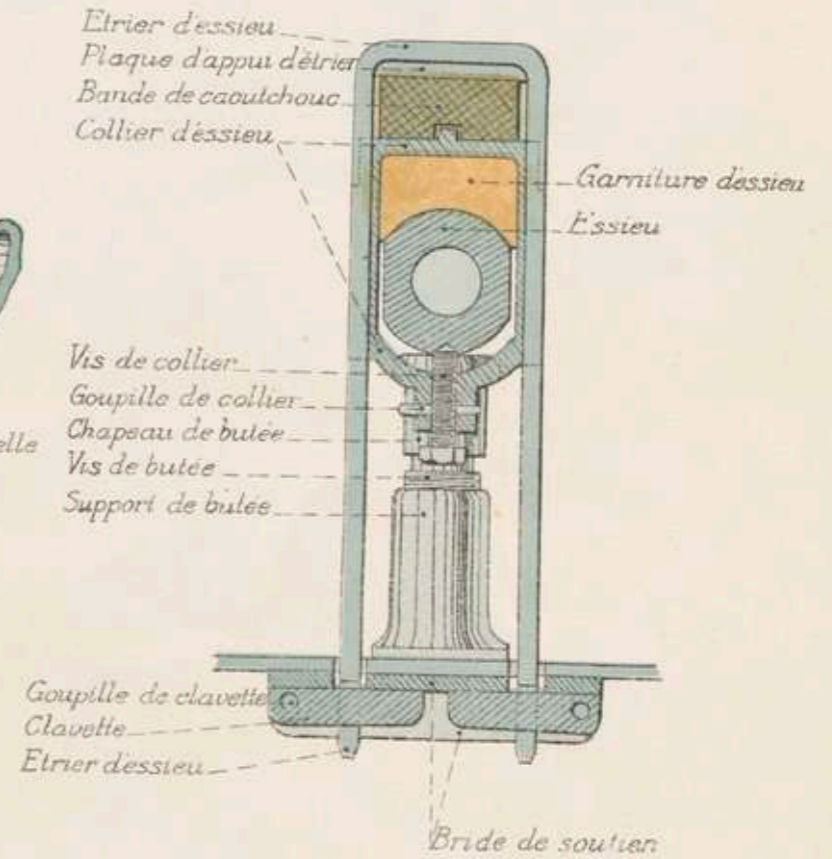
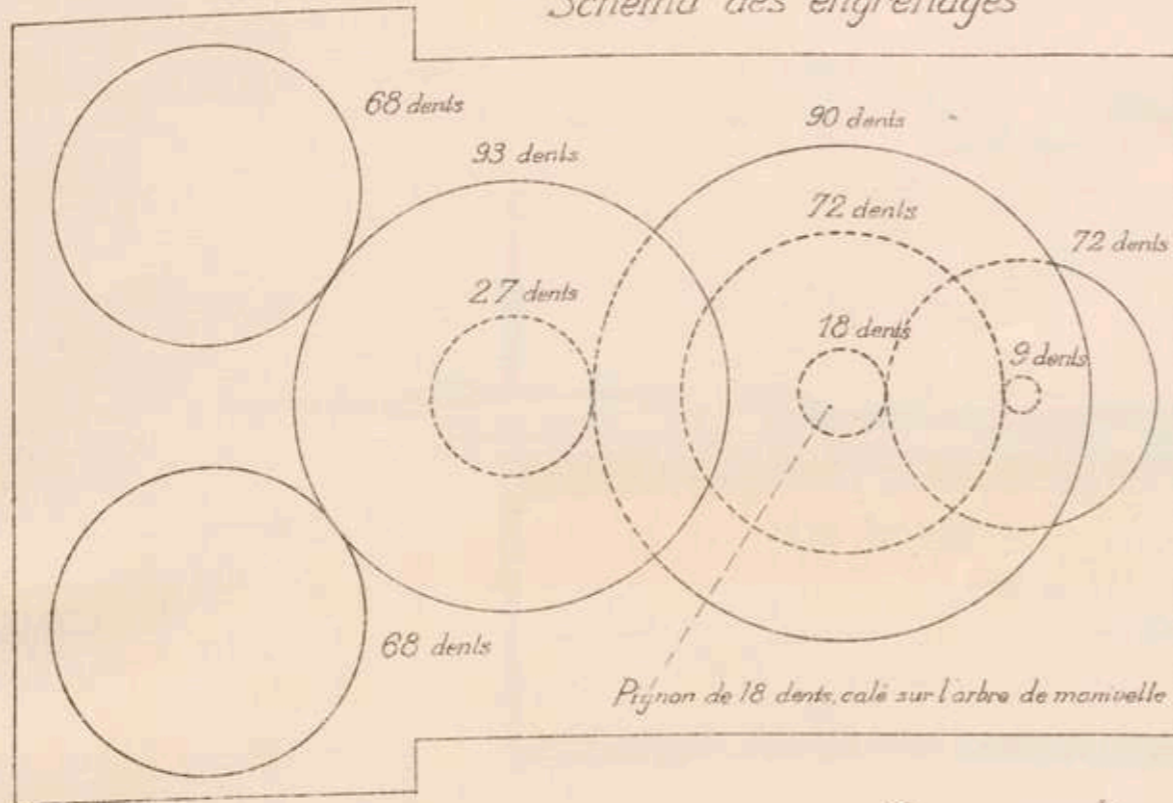
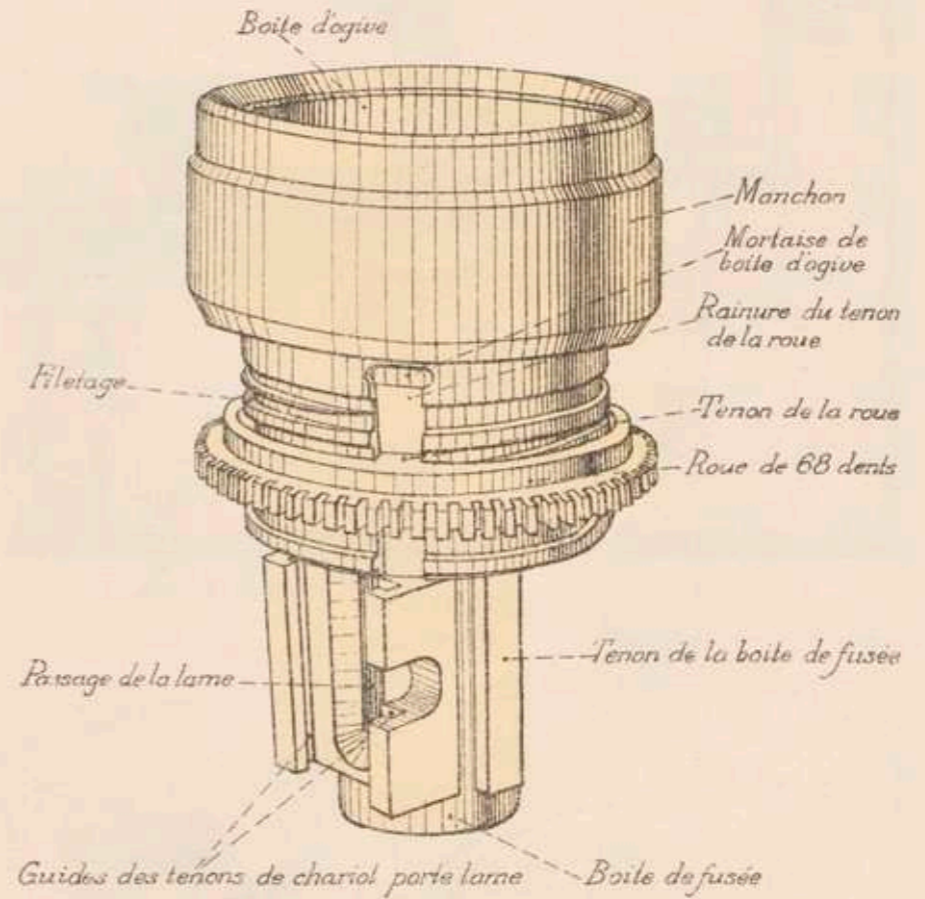

Coupe par l'axe

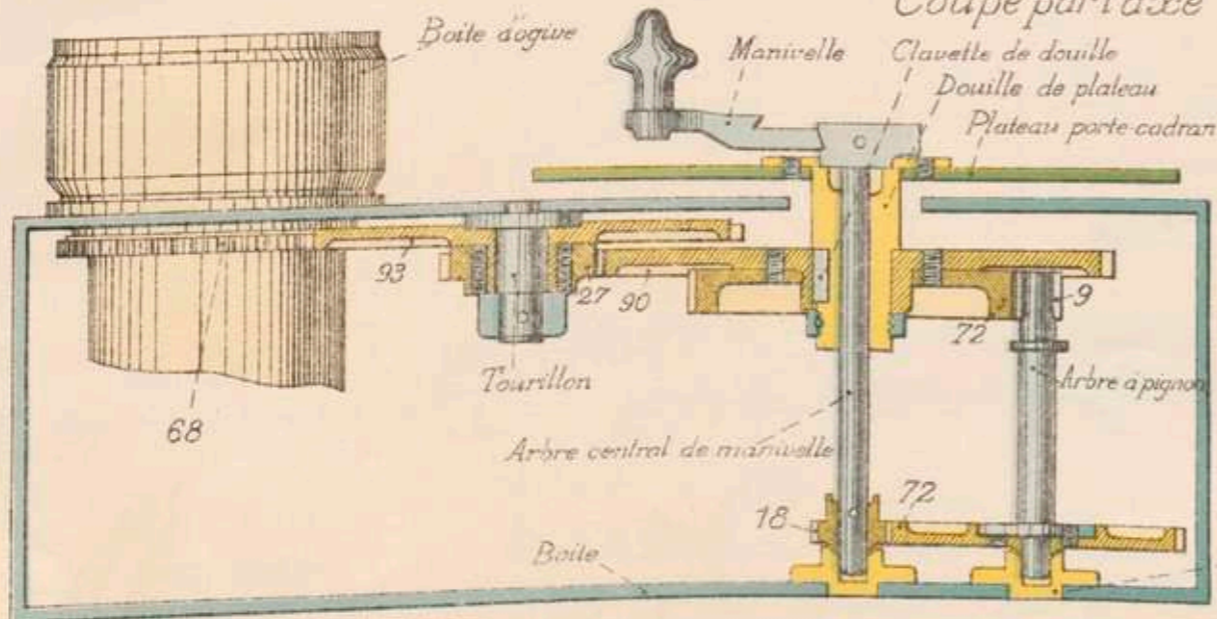

Porte-lame et chariot porte-lame

Logement du tenon de la fusée
Planche XXXIV
Boîte d'ogive
Bague

Coupe longitudinale
(Mouvement du cadran enlevé)

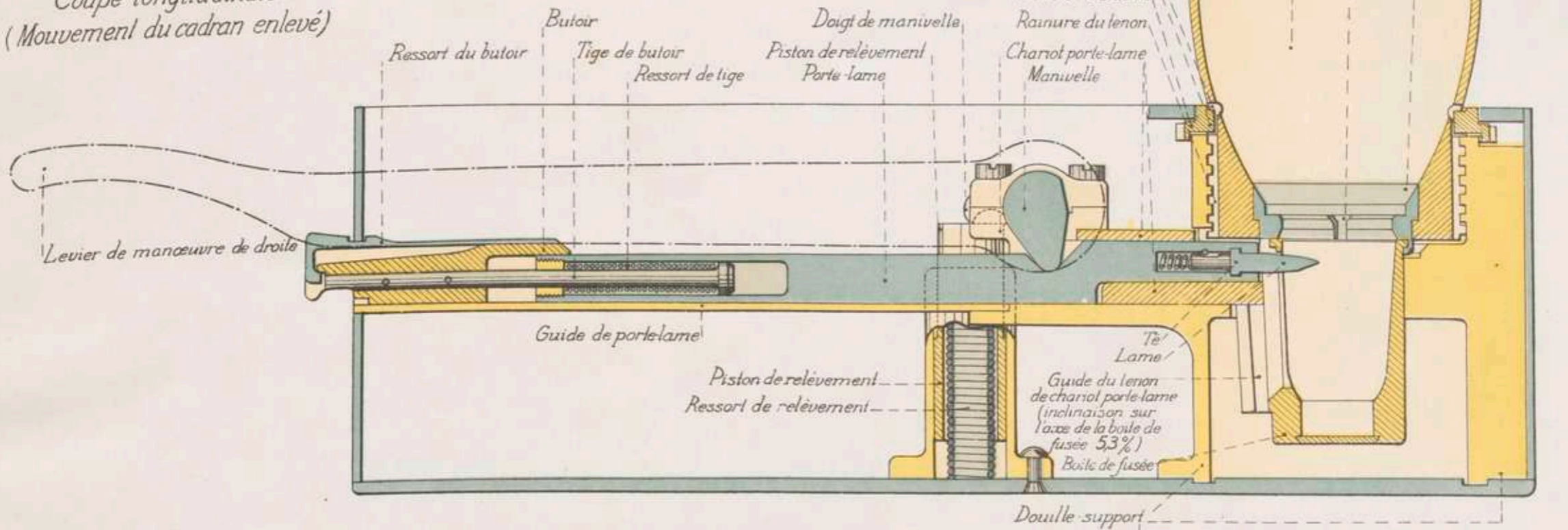

Plan
(Plaque supérieure, boîte d'ogive
et mouvement du cadran enlevés)

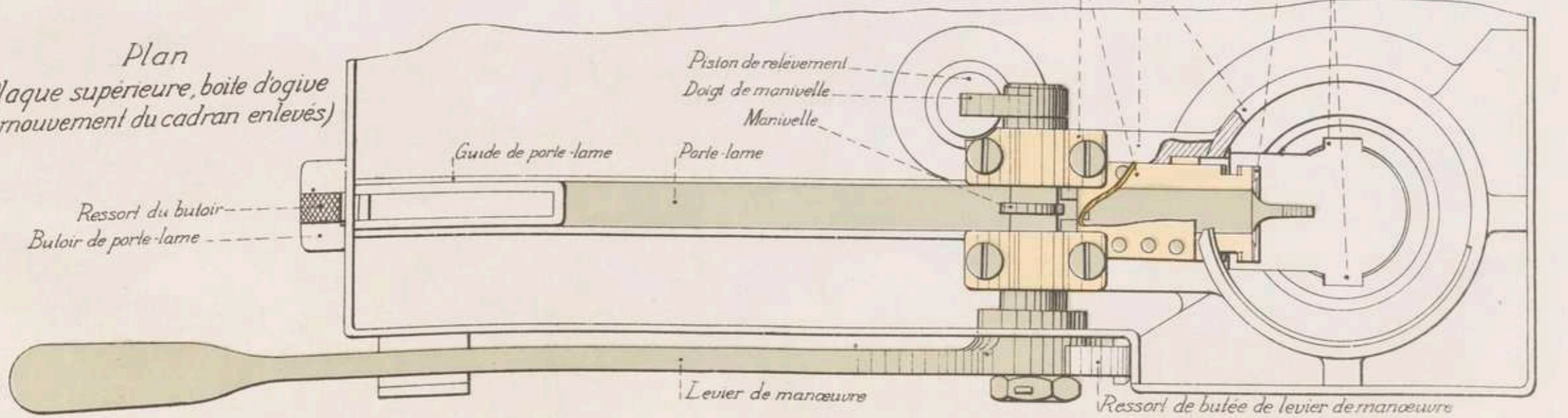

Pompe de Batterie M^{le} 1917

Remplisseur à vis

Ajutage de vidange du frein

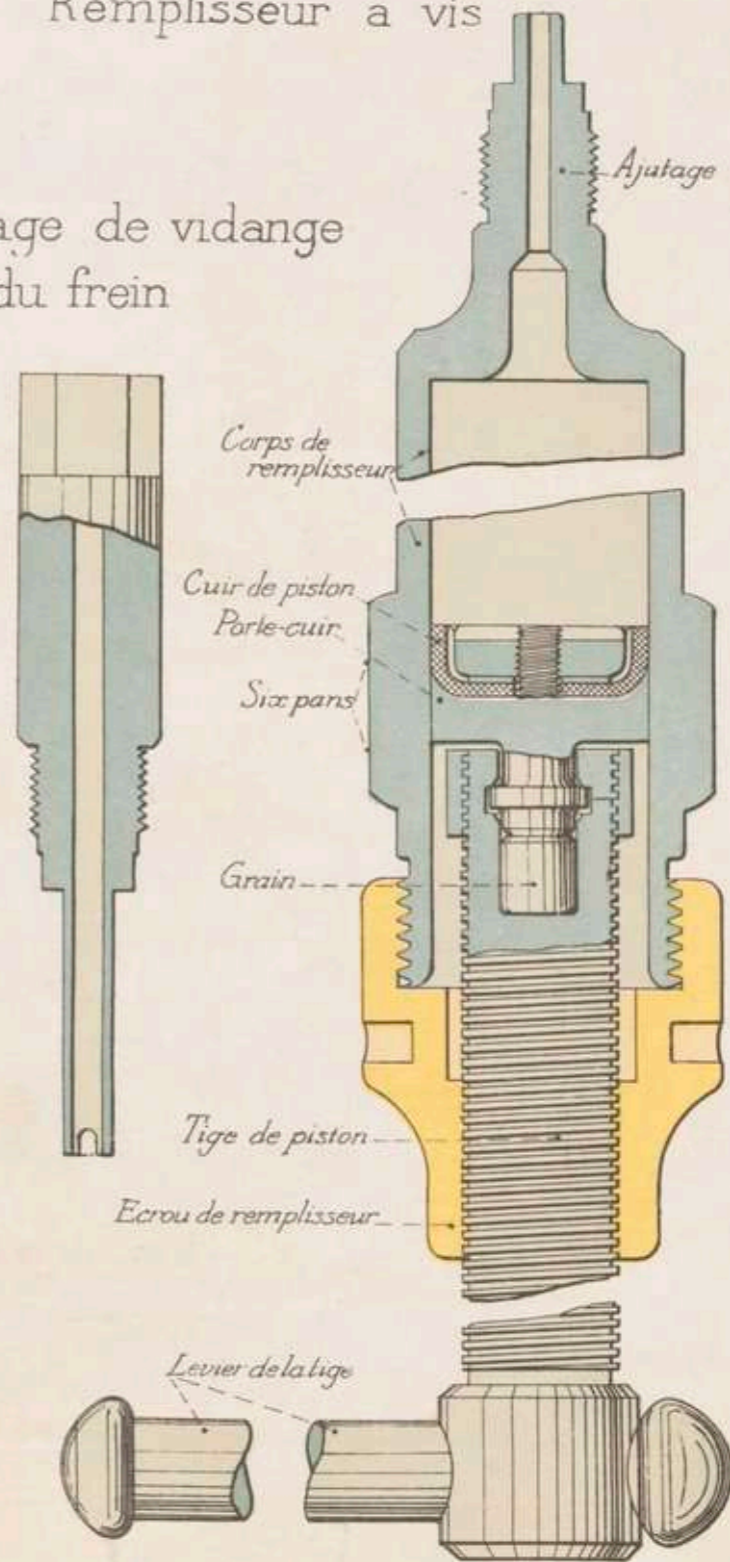
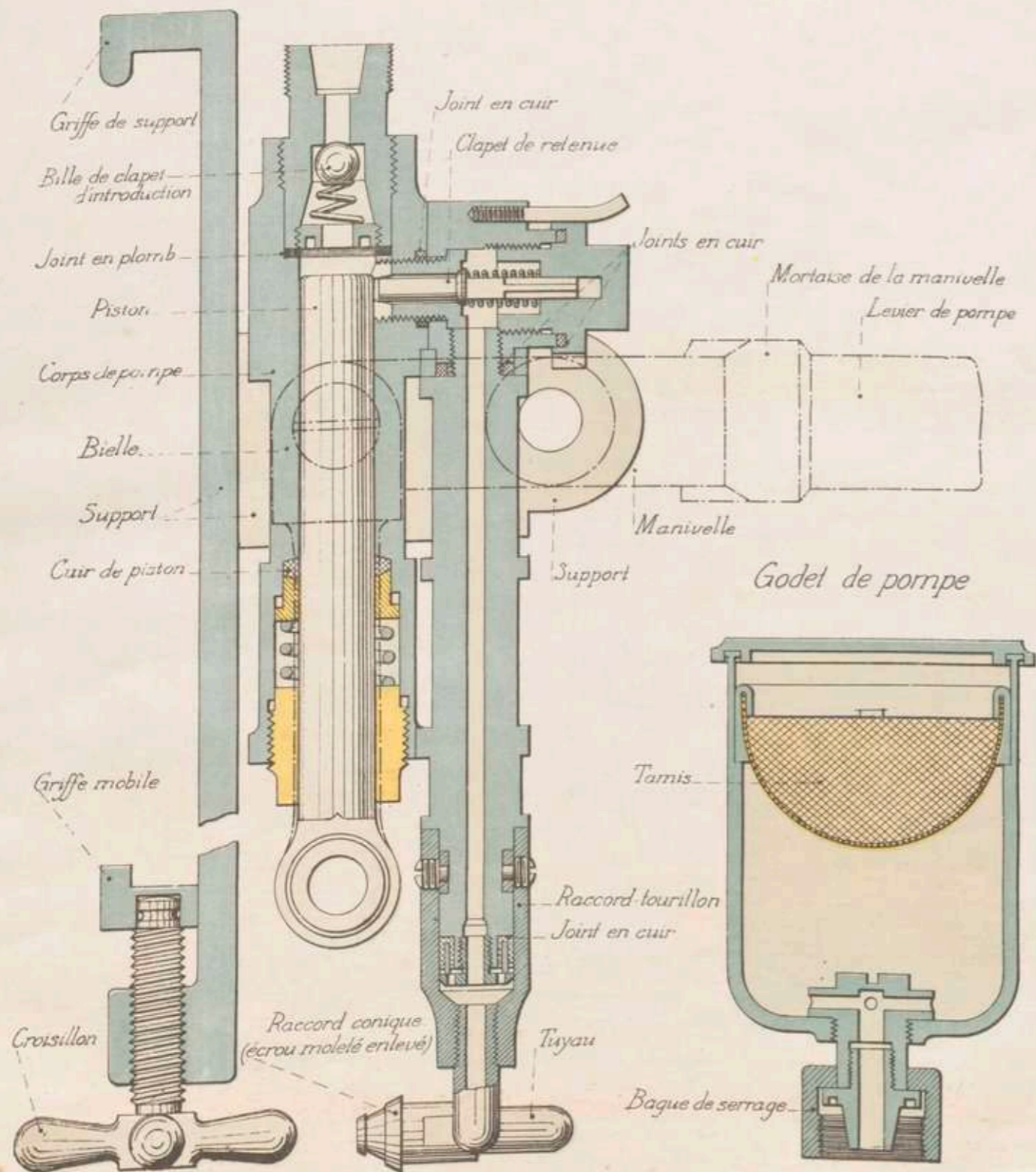

Timon de rechange – Bout de timon

Planche XXXVI

Ensemble vu en plan

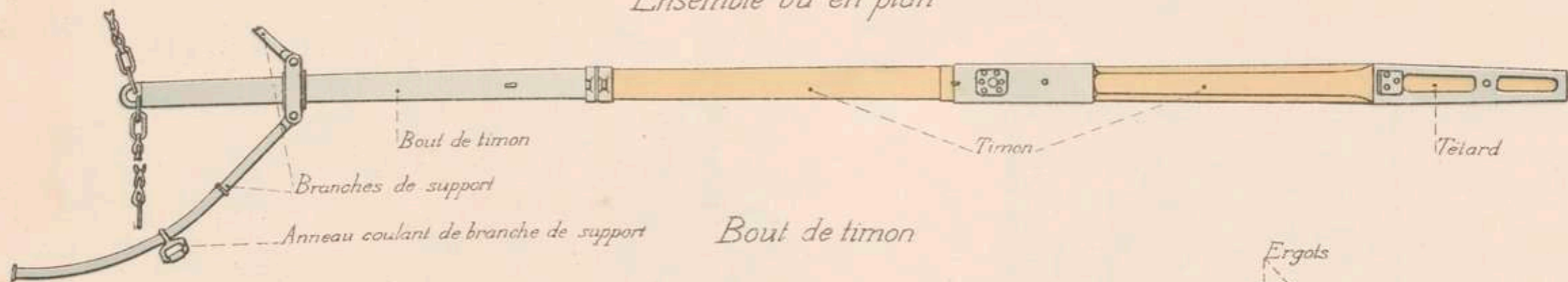

Bout de timon

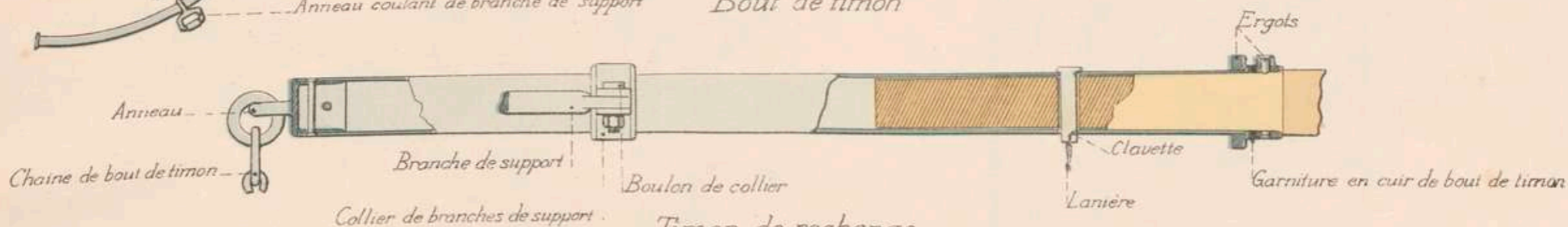

Timon de rechange
Partie intermédiaire



Partie arrière

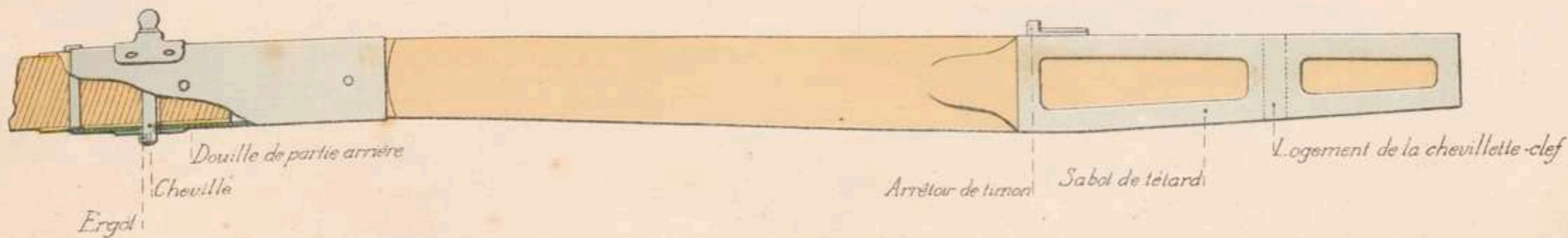

Galerie porte-sacs

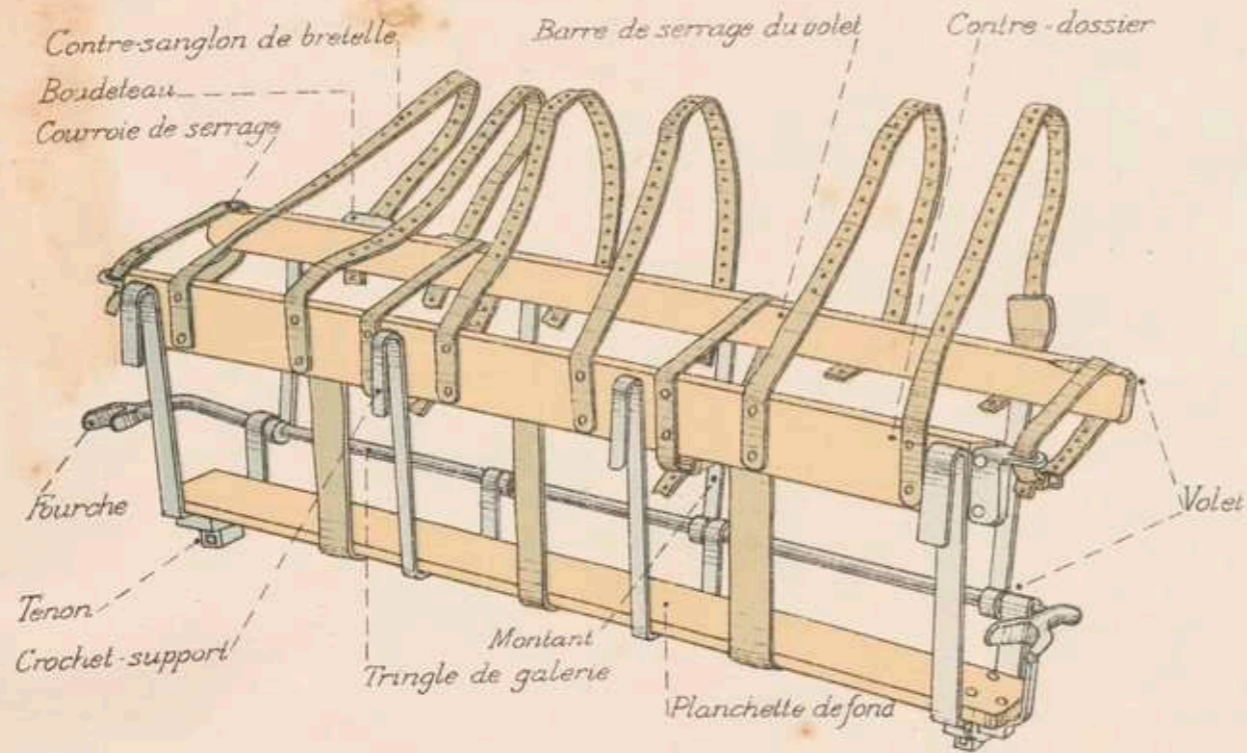

Sac aux armements Coupe AB

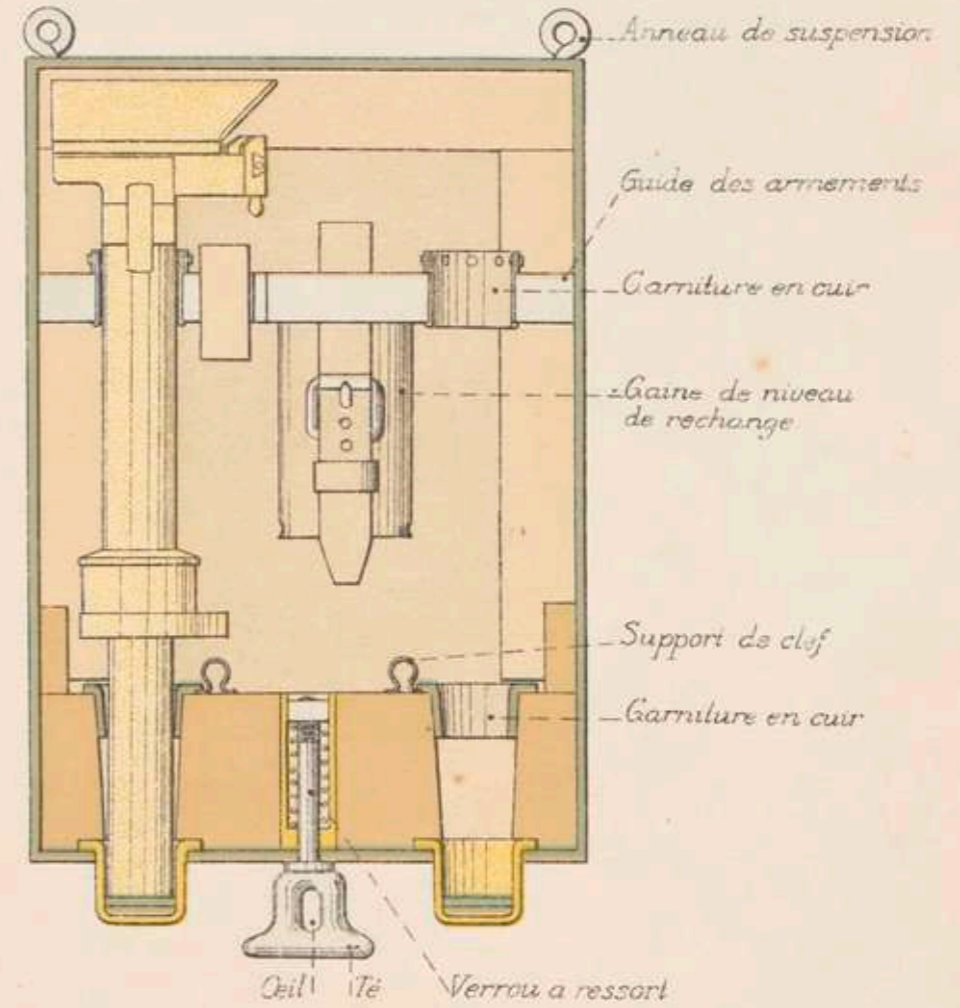

Refouloir à tête évidée

