



III  
64-2-9(11)

Biblioteca de Ingenieros del Ejercito.



Inscripción...	{	Folio.....	208
		Número.....	6180
Clasificación..	{	División.....	B
		Subdivisión	9-10
Colocación....	{	Estante.....	7
		Tabla.....	2ª
		Número.....	9

0-7 1-  
COLECCIÓN

DE

LÁMINAS DEL MATERIAL

DE LA

ARTILLERÍA ESPAÑOLA

---

---

**Tomo II del Apéndice**

---

---



MADRID

IMPRESA DE GERARDO SERRANO

FELIPE IV, NÚM. 11

1922

# INDICE

del tomo II del Apéndice de las láminas del Material de Artillería.



LAMINA	1. <sup>a</sup>	Atalaje modelo 1912	Car.	Montaña.	LÁMINA	34	Carro de batería n.º 1.
—	2. <sup>a</sup>	Idem	id.	id. id.	—	35	Idem id. id.
—	3. <sup>a</sup>	Idem	id.	id. id.	—	36	Idem id. id.
—	4. <sup>a</sup>	Idem	id.	id. id.	—	37	Idem id. id.
—	5. <sup>a</sup>	Idem	id.	id. id.	—	38	Idem id. id.
—	6. <sup>a</sup>	Idem	id.	id. id.	—	39	Idem id. id.
—	7. <sup>a</sup>	Aparato para engarzar proyectiles de campaña modelo 1914.			—	40	Idem id. id.
—	8. <sup>a</sup>	Idem	id.	id. id. id.	—	41	Idem id. id.
—	9. <sup>a</sup>	Idem	id.	id. de montaña.	—	42	Idem id. id.
—	10	Idem	id.	id. id.	—	43	Idem id. id.
—	11	Collerón para atalaje de campaña, modelo 1915.			—	44	Idem id. id.
—	12	Idem	id.	id. id. id.	—	45	Idem id. id.
—	13	Idem	id.	id. id. id.	—	46	Idem id. id.
—	14	Equipo y montura para los Regimientos montados del arma de Artillería, modelo 1914.			—	47	Idem id. id.
—	15	Idem			—	48	Idem id. id.
—	16	Idem			—	49	Idem id. id.
—	17	Idem			—	50	Idem id. id.
—	18	Idem			—	51	Idem id. id.
—	19	Idem			—	52	Carro de batería n.º 2.
—	20	Idem			—	53	Idem id. id.
—	21	Idem			—	54	Idem id. id.
—	22	Idem			—	55	Idem id. id.
—	23	Idem			—	56	Idem id. id.
—	24	Idem			—	57	Idem id. id.
—	25	Granada rompedora de 7'5 cm. para campaña.			—	58	Idem id. id.
—	26	Cajón de empaque para transporte de cartuchos para C. de campaña de 7'5 cm.			—	59	Idem id. id.
—	27	Llave automática para graduar espoletas de tiempo de 47" md. 1913.			—	60	Idem id. id.
—	28	Idem	id.	id. id. id. id.	—	61	Idem id. id.
—	29	Idem	id.	id. id. id. id.	—	62	Idem id. id.
—	30	Carro de batería n.º 1.			—	63	Carro de Grupo.
—	31	Idem	id.	id.	—	64	Idem id.
—	32	Idem	id.	id.	—	65	Idem id.
—	33	Idem	id.	id.	—	66	Cargas de proyección para M. de Bc. de 21 cm. modelo 1895.
					—	67	Cartuchos y cargas para O. de Bc. de 15 cm. modelo 1891.
					—	68	Carga y cartuchos para O. de Bc. de 21 cm. modelo 1885.
					—	69	Cargas de proyección de pólvoras sin humo para M. de Bc. de 9 cm. modelo 1891.

# ATALAJE Md. 1912 Car. Mña.

Escala 1/5

Collerón.

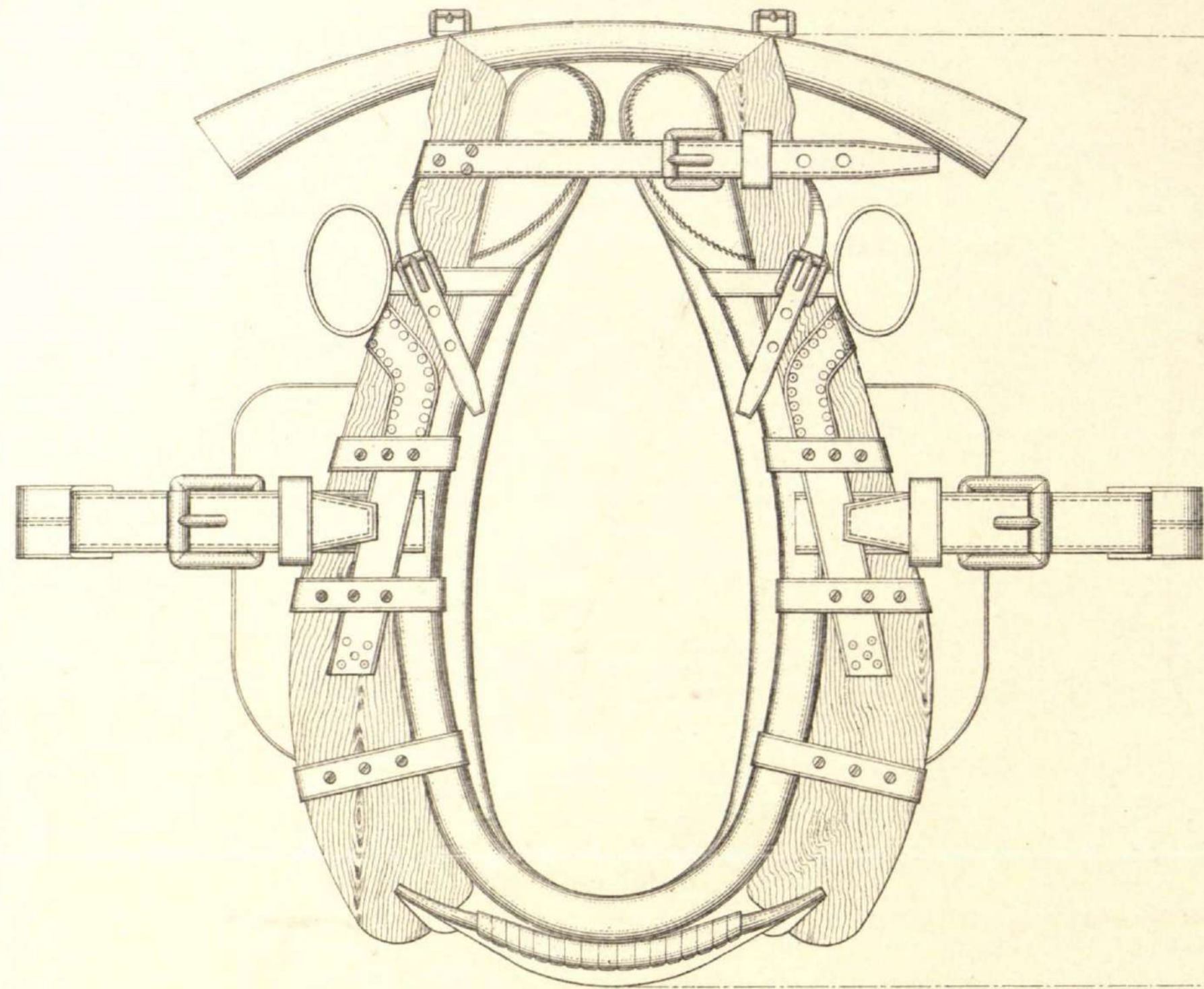

Bridón.

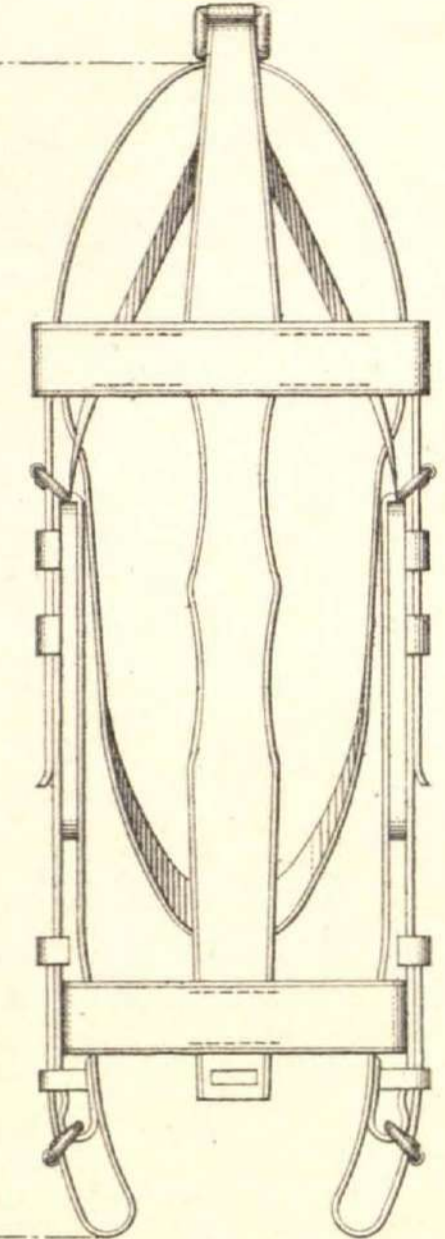
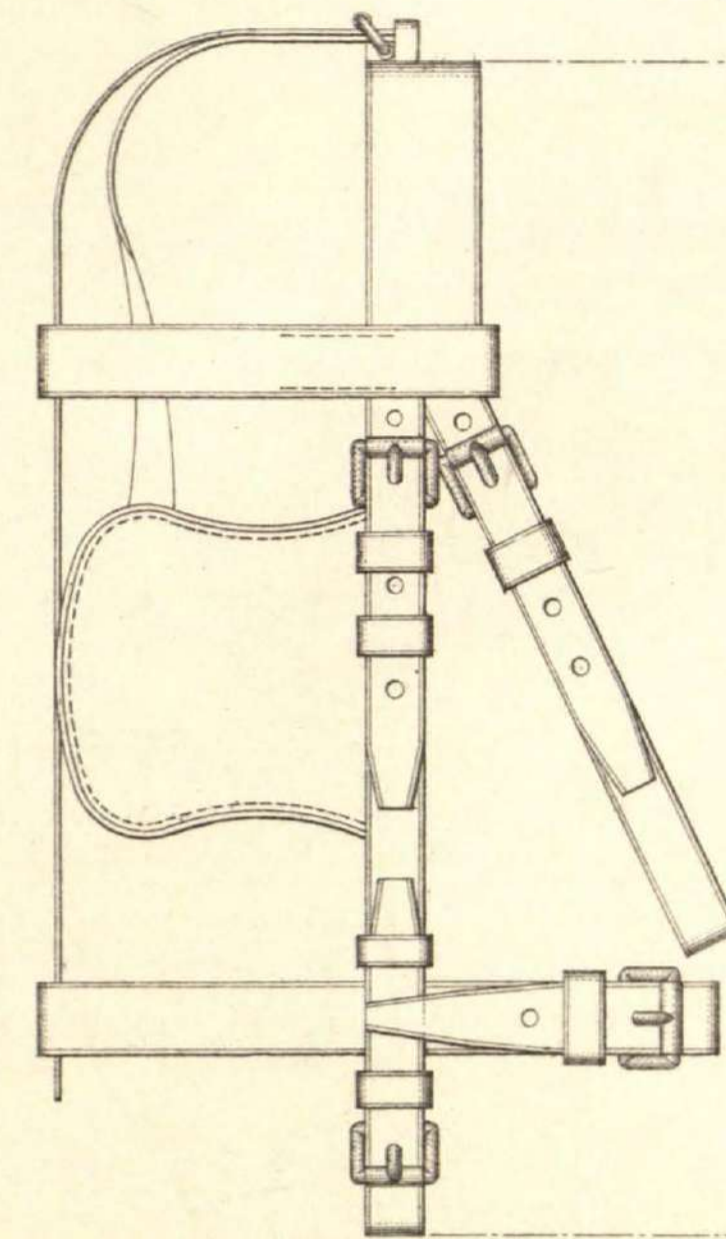
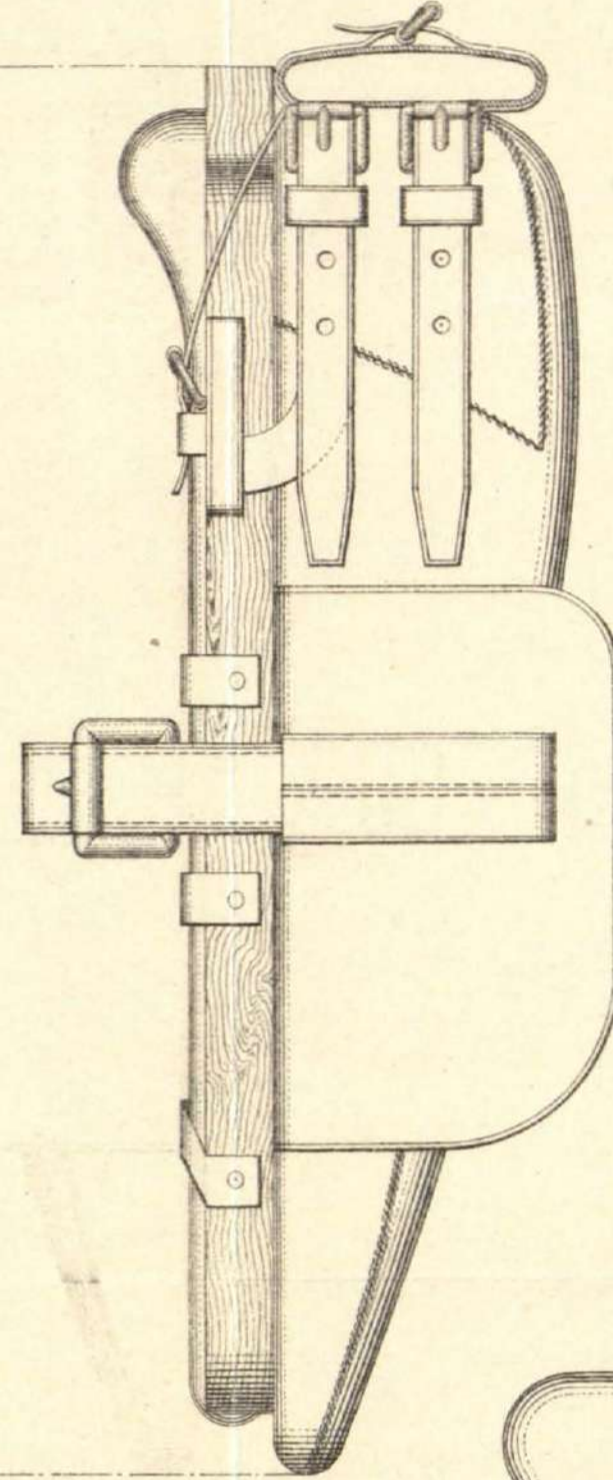

Cuerpo del collerón.

Monterilla del collerón.

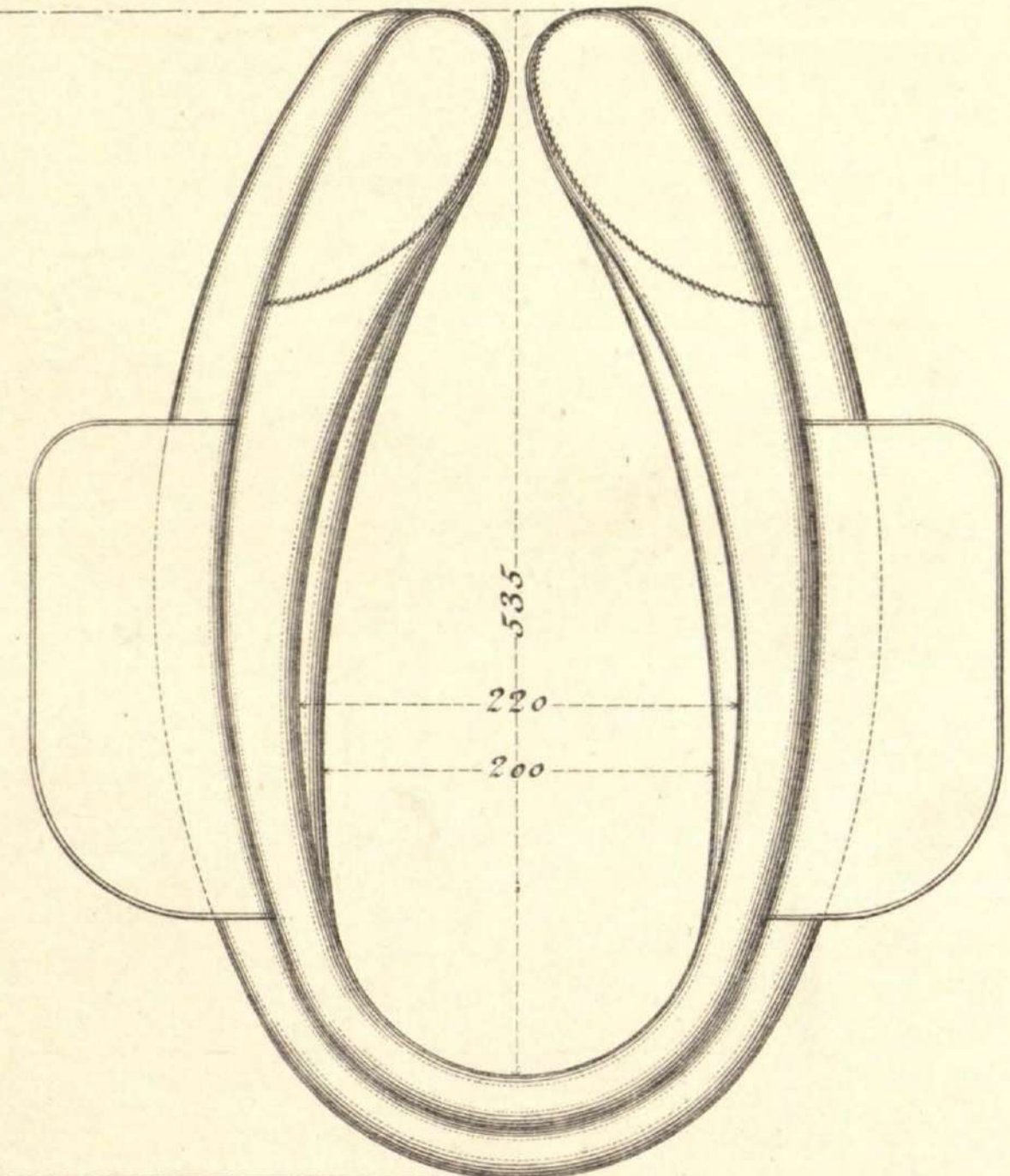
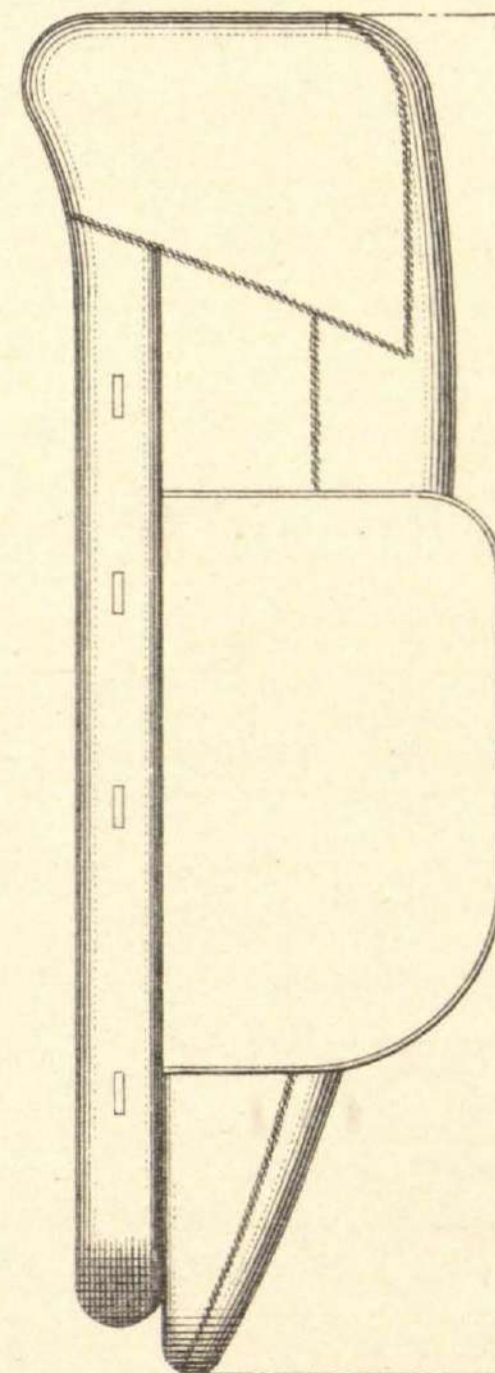
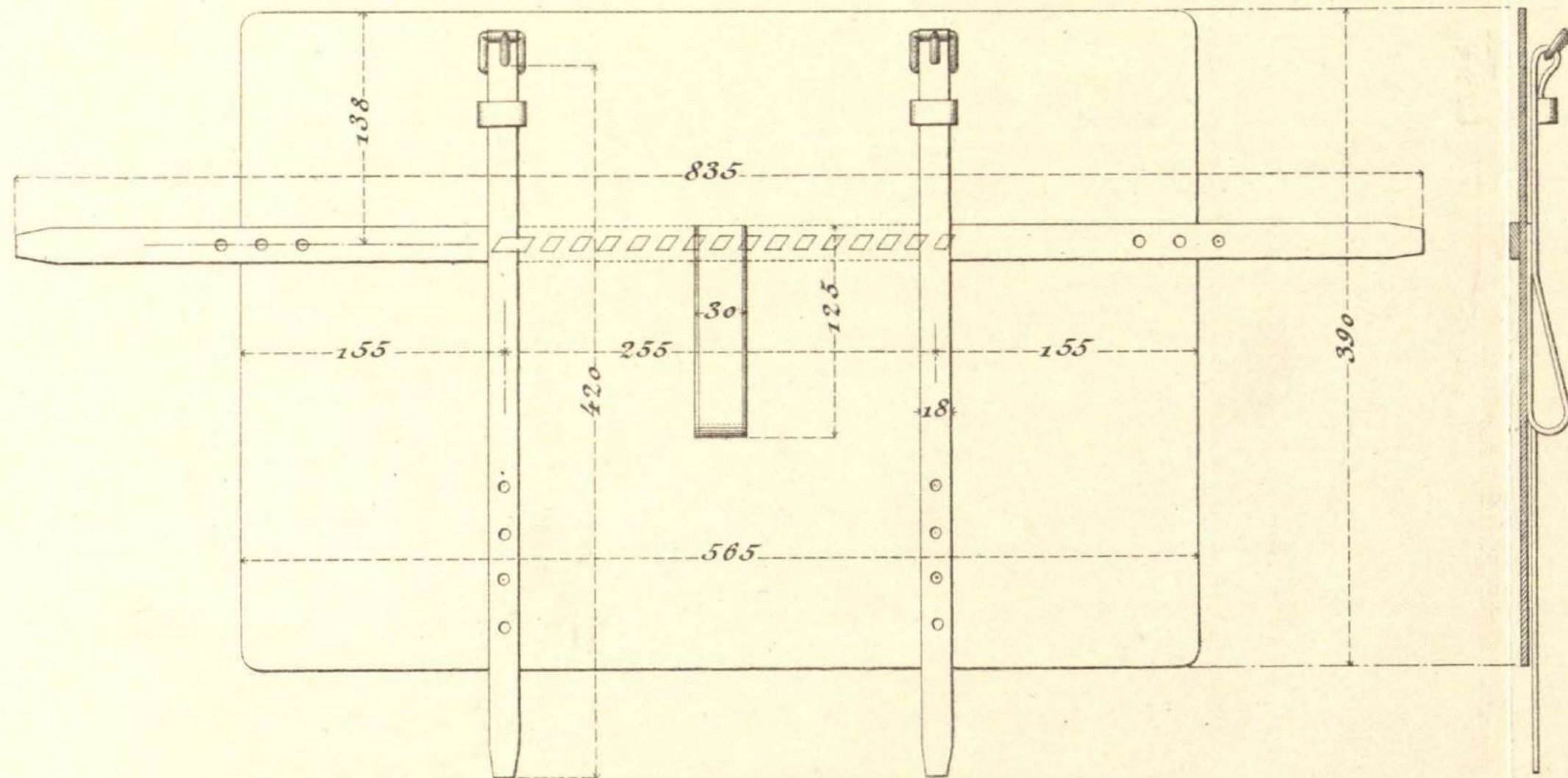

# ATALAJE Md. 1912 Car. Mña.

Atalaje de varas. (E=1/10.)

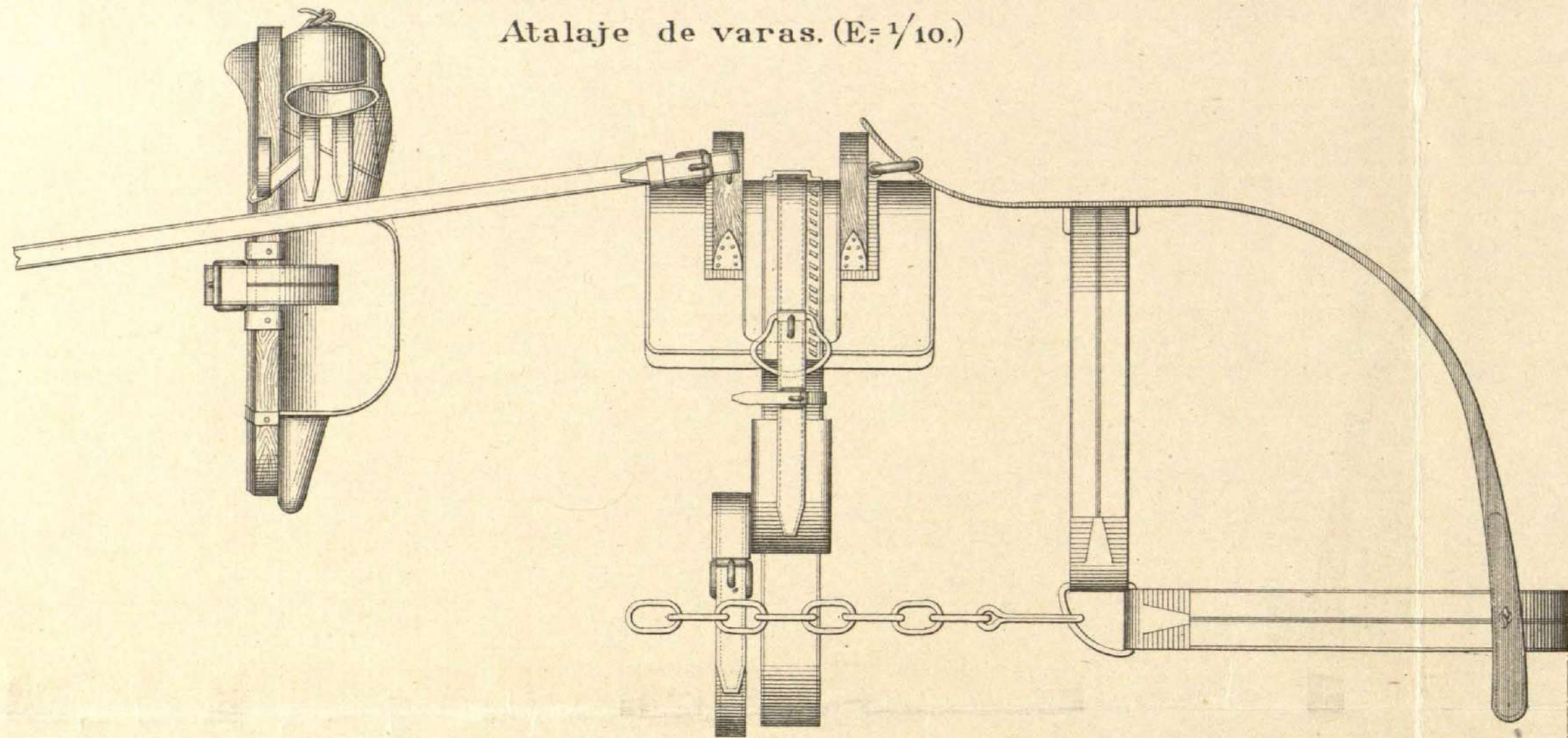

Cabezada. (E=1/5.)

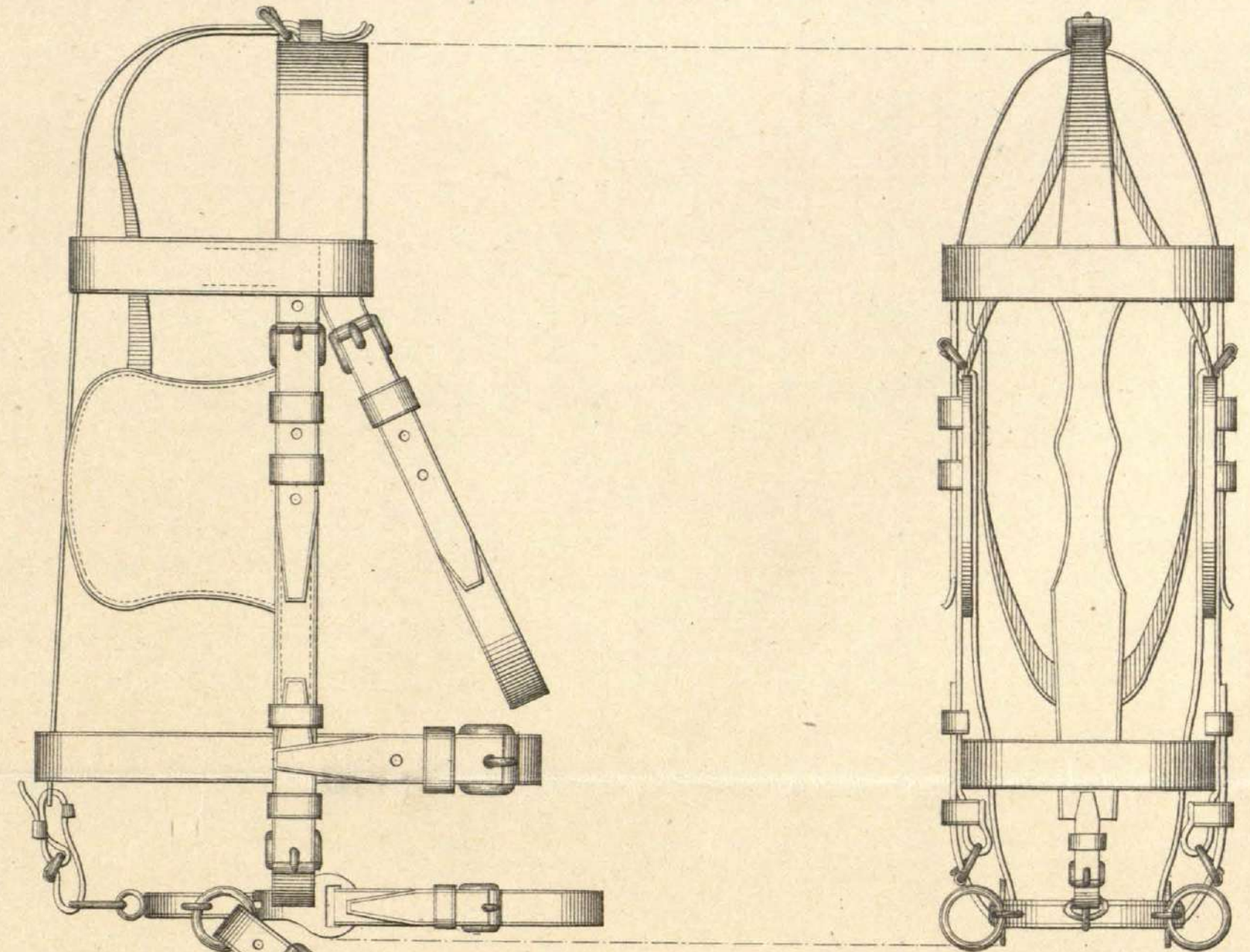

Anleojeras. (E=1/5.)

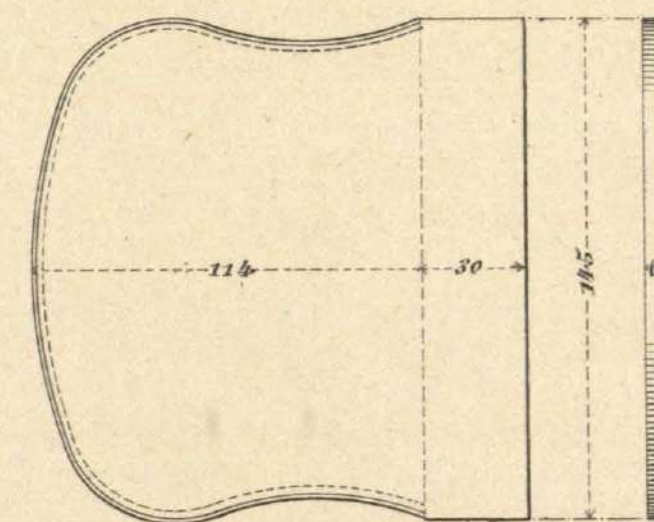

Barbada de serreta. (E=1/5.)

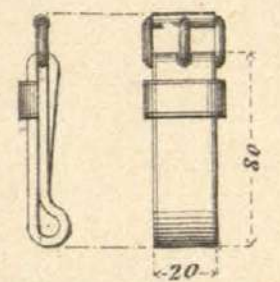
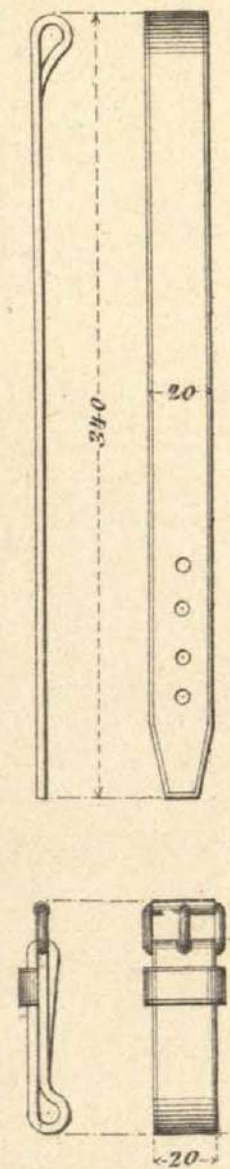

# ATALAJE Md. 1912 Car. Mña.

Escala 1/5.

Silopin.

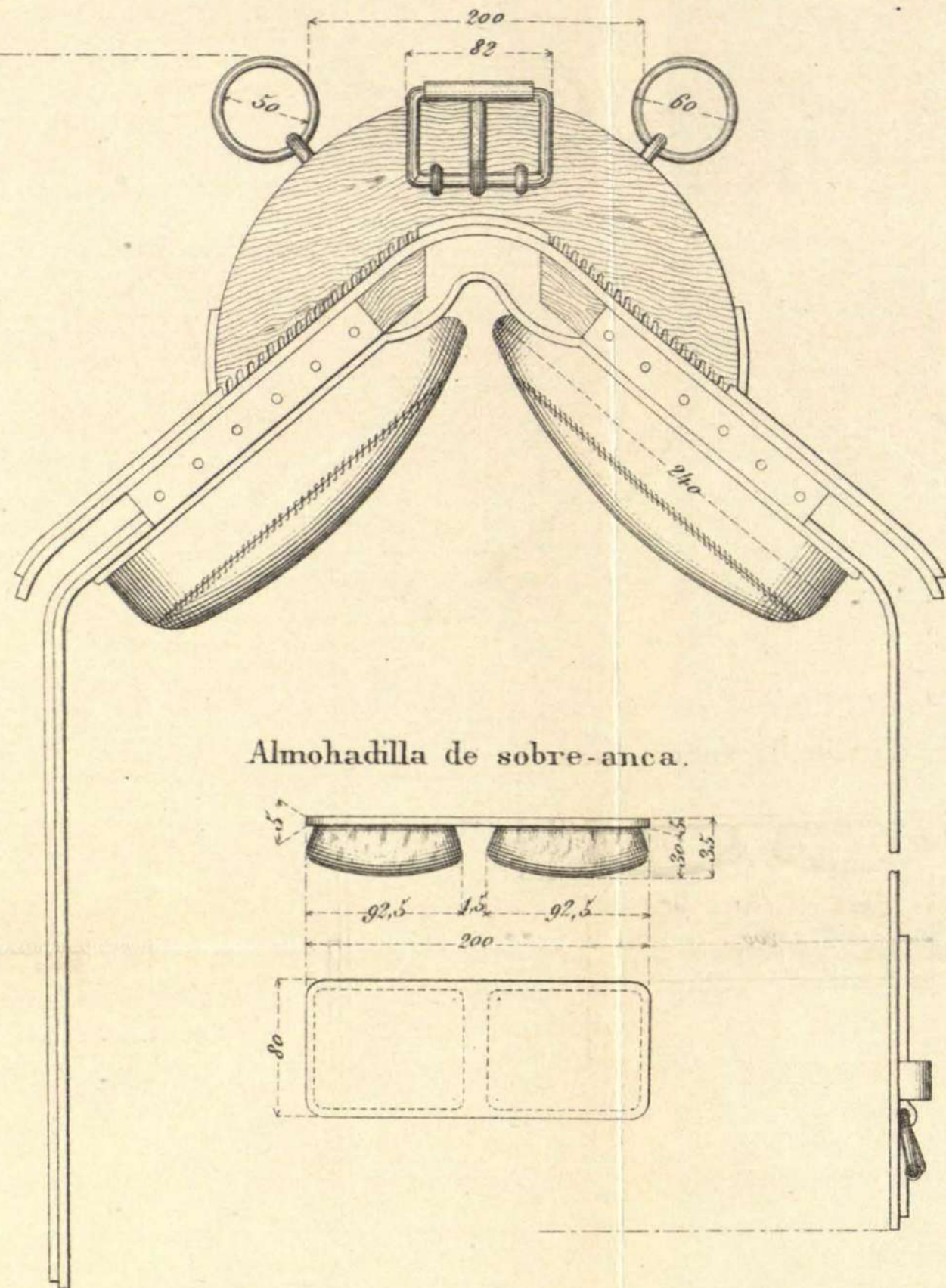
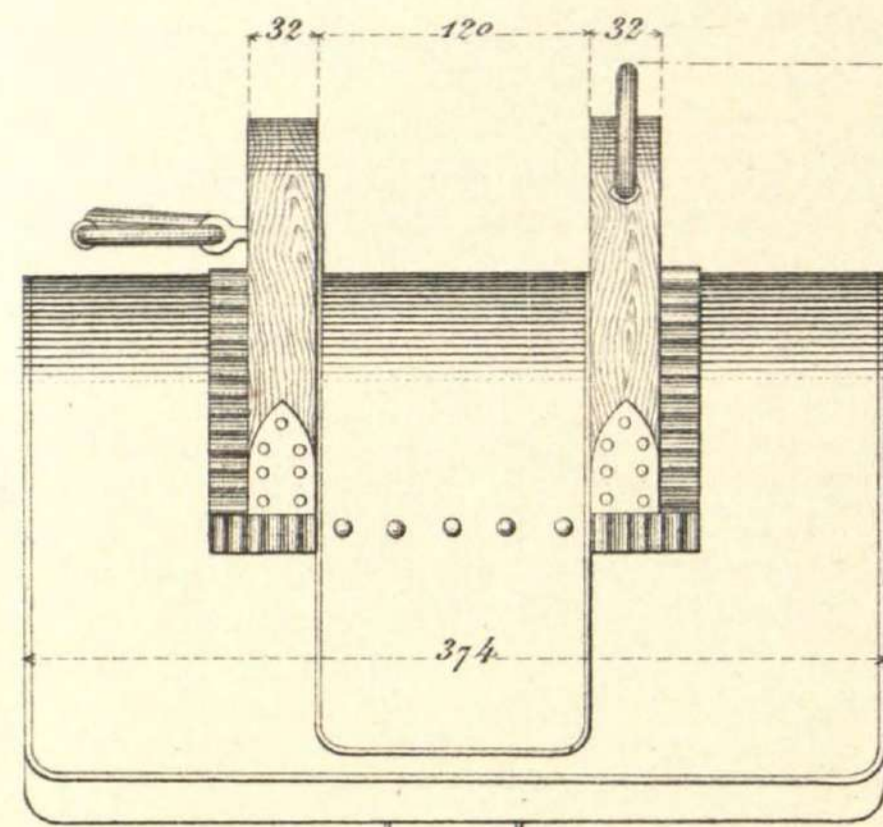

Armadura del silopin.

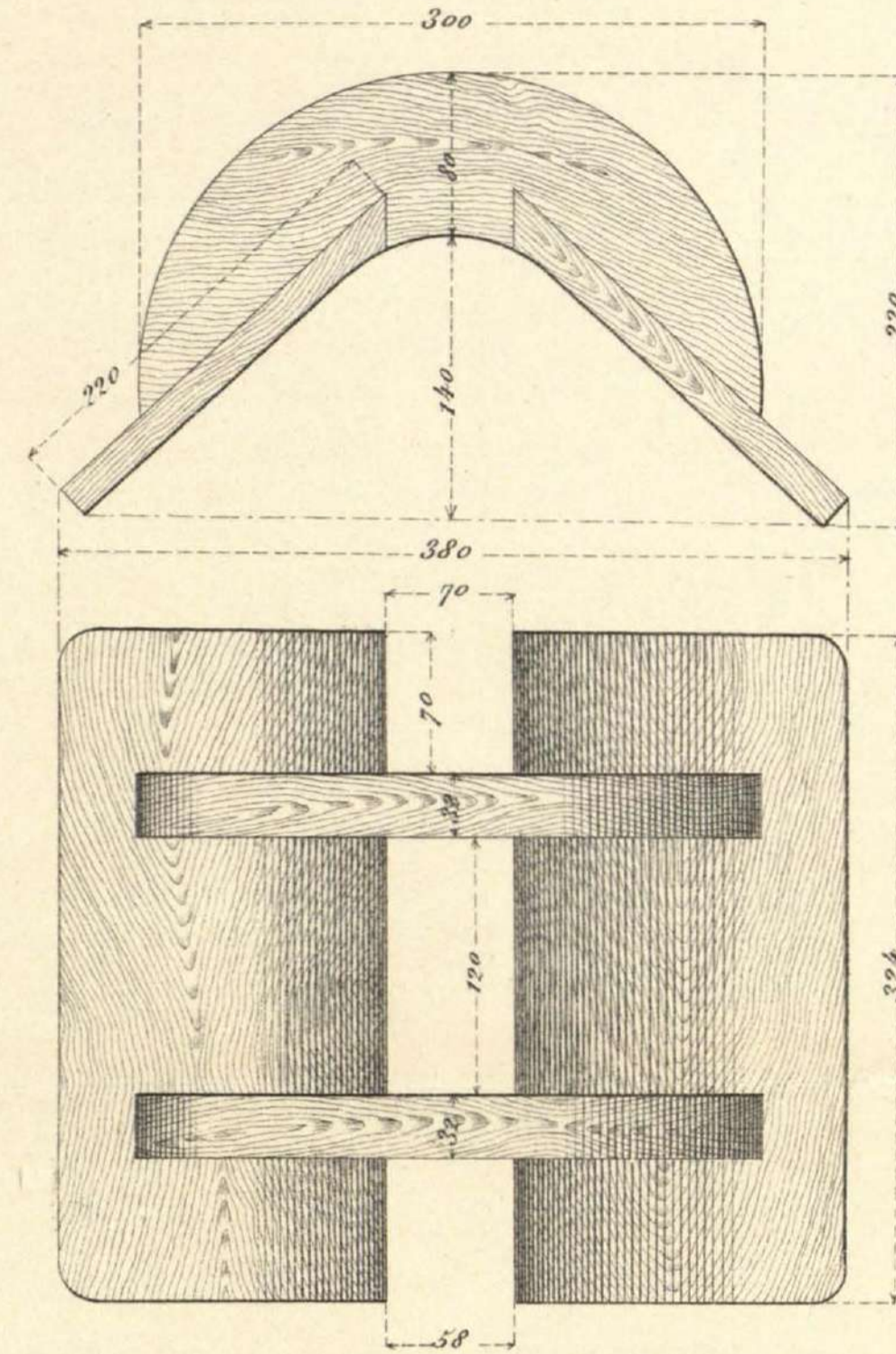

Rozadero del silopin.

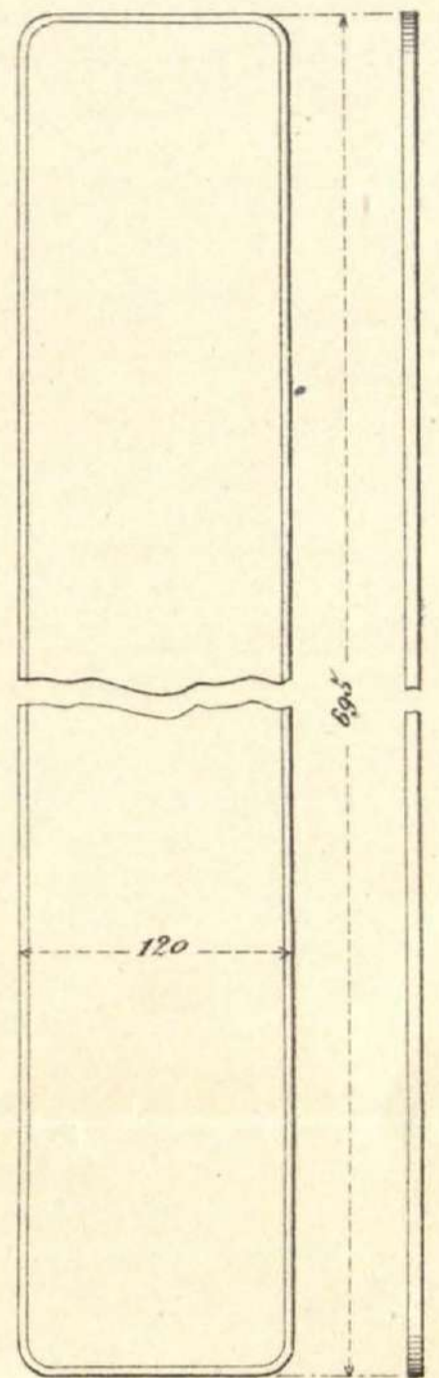

Almohadilla de sobre-anca.

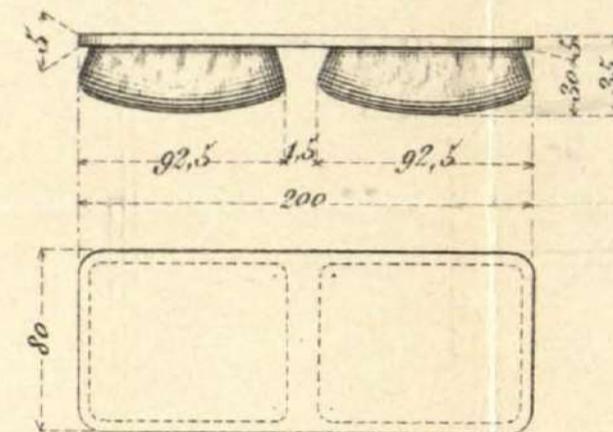

Faldones del silopin.

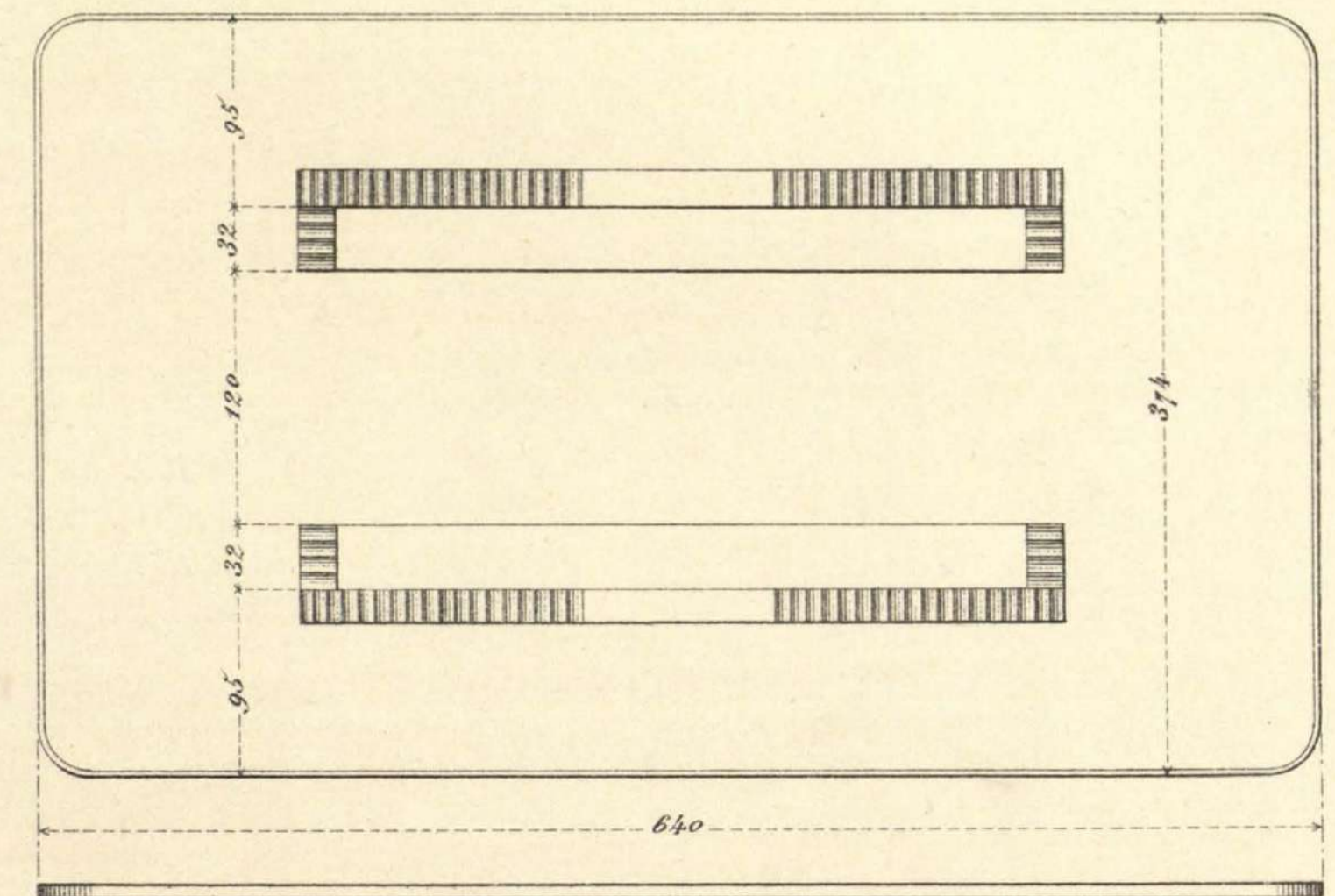

Barriguera del silopin.

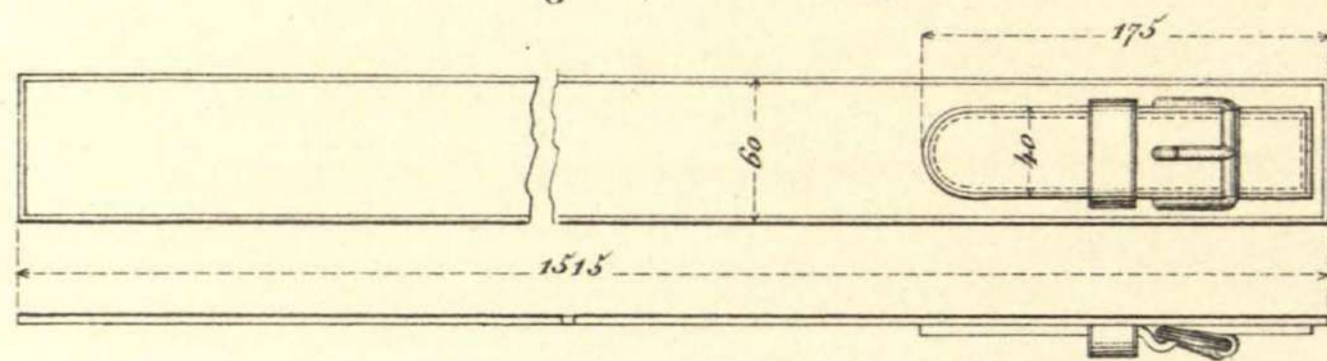

Punta de la barriguera.

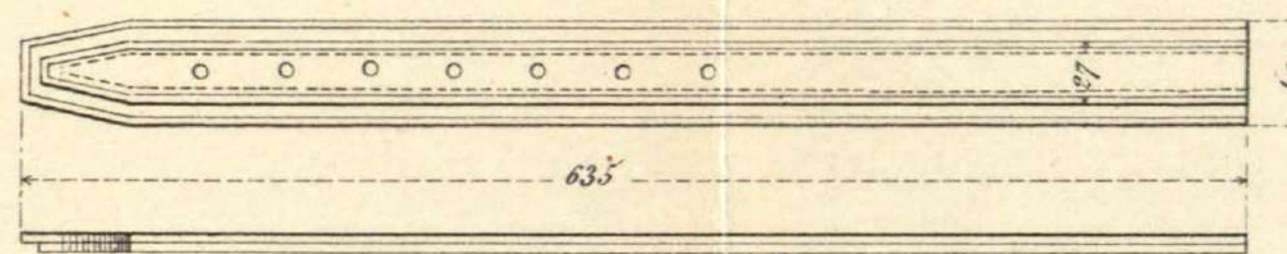

Barriguera de varas.

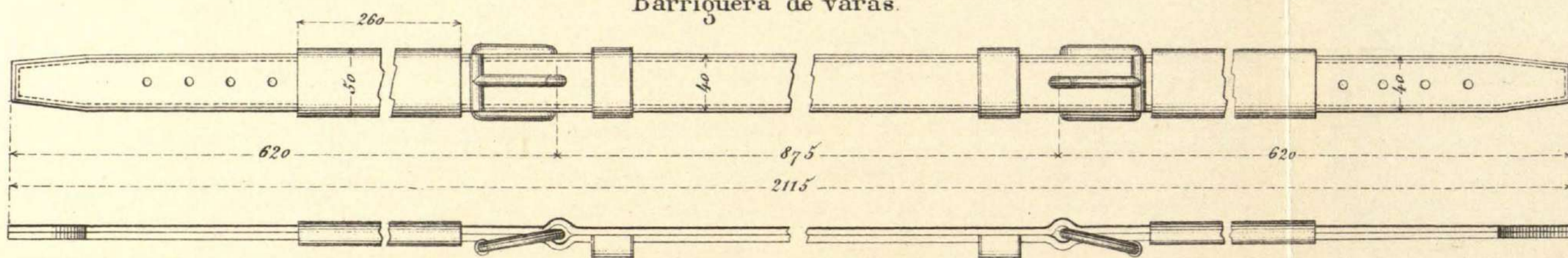

# ATALAJE Md. 1912 Car. Mña.

Escala 1/5

Sufra

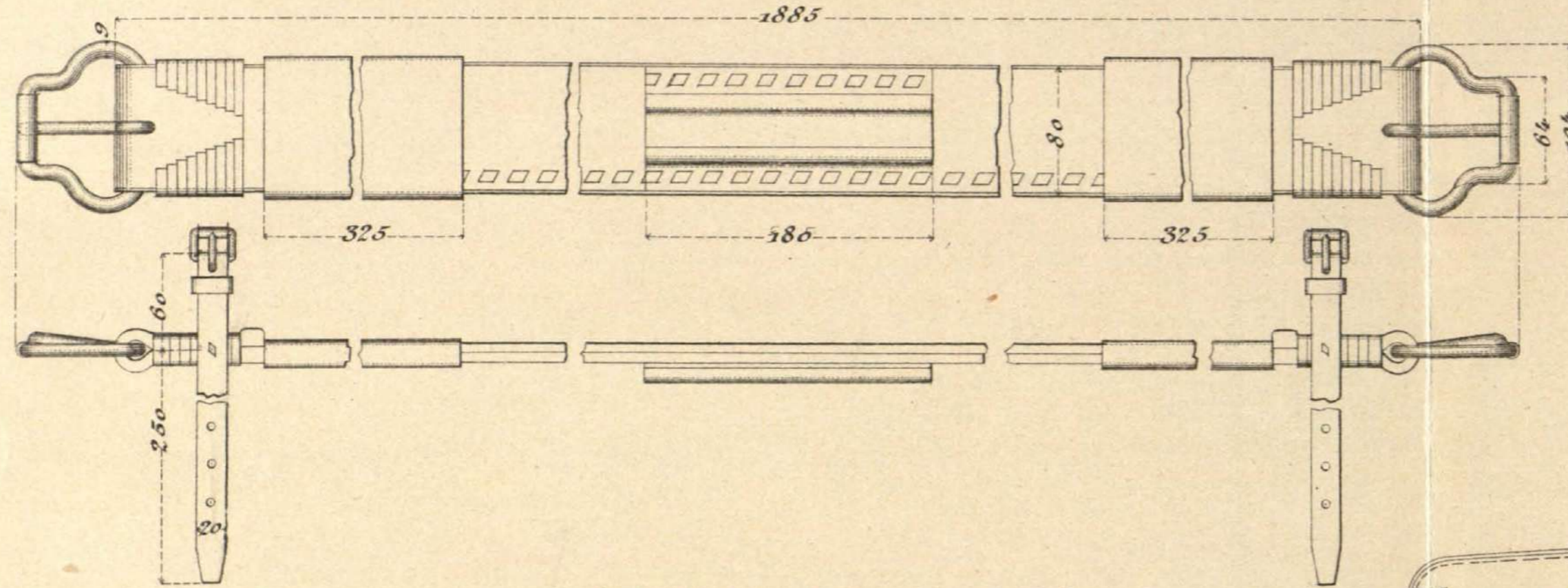

Cadenas de retranca

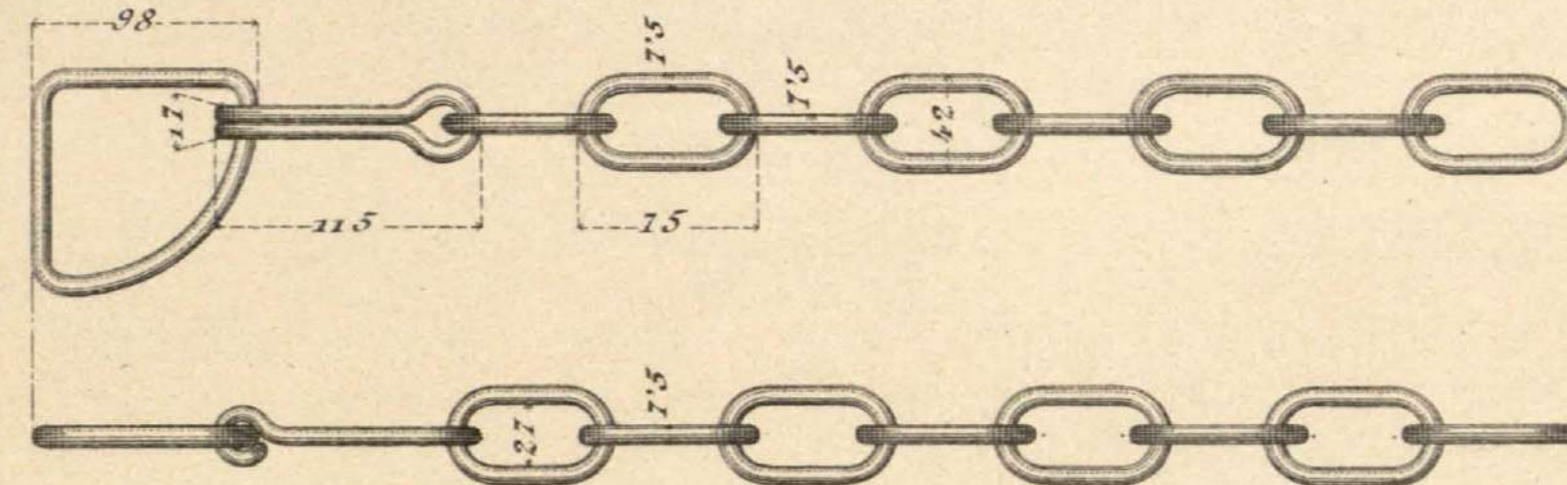

Francalete de la sufra

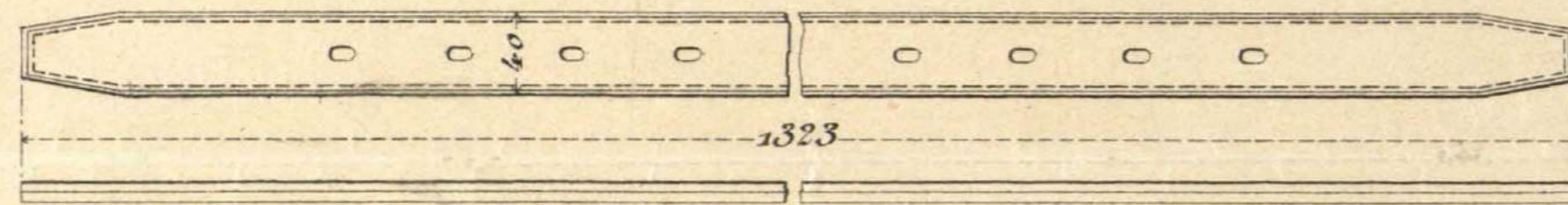

Caida de retranca.

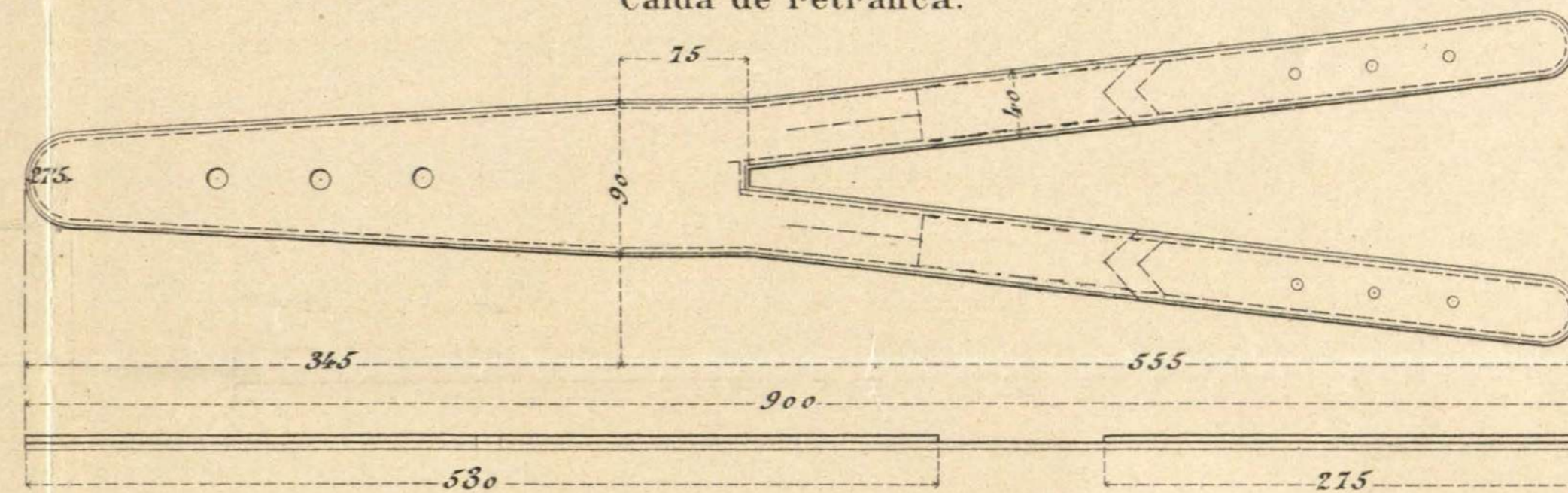

Riendas

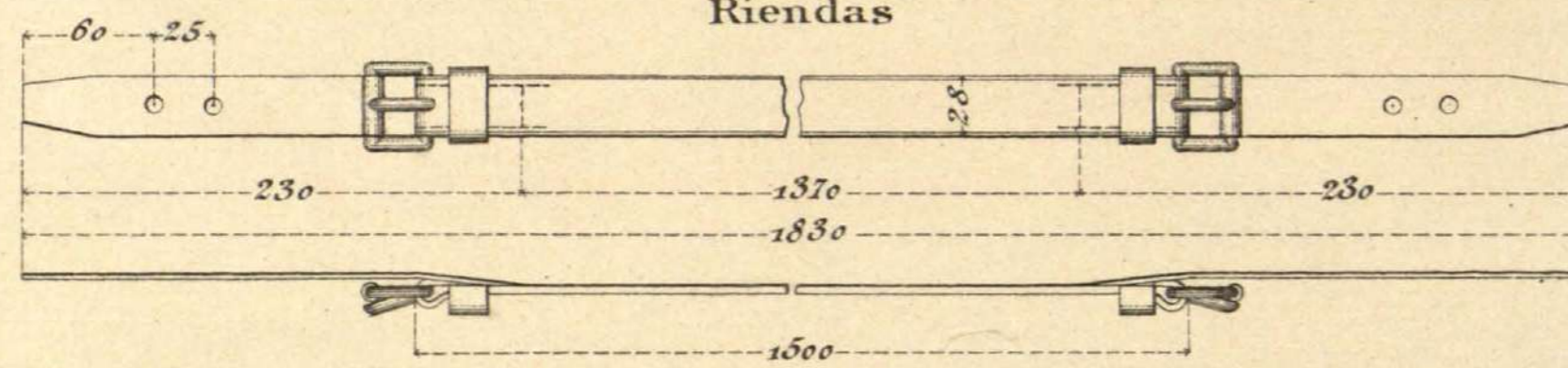

Retranca

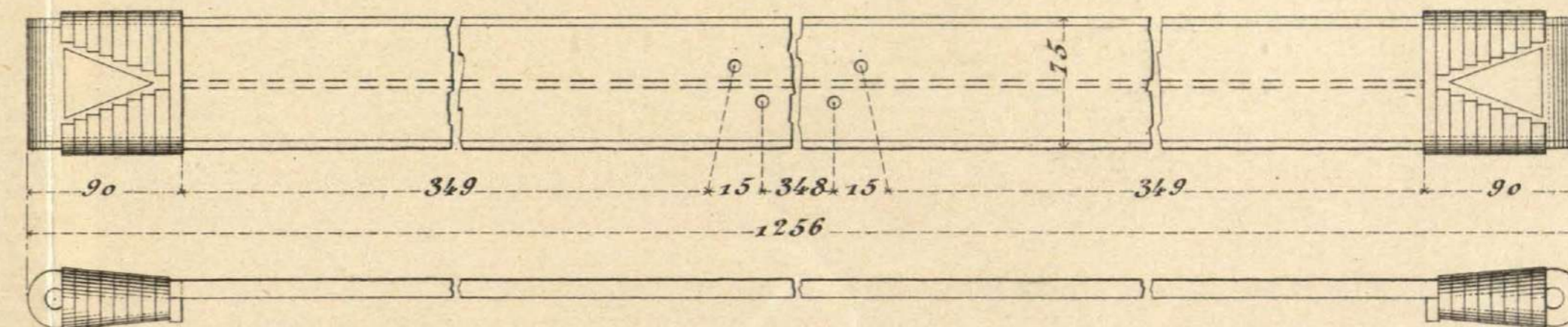

Rozaderos de los francaletes de enganche del collarón

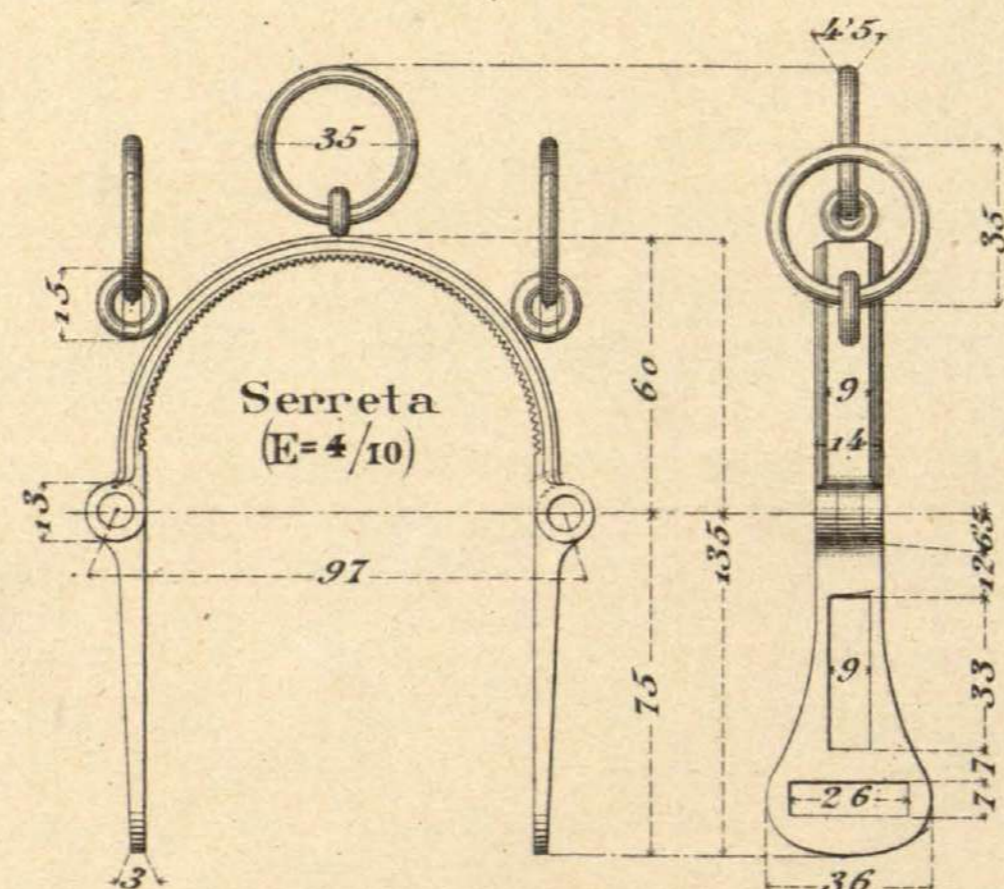
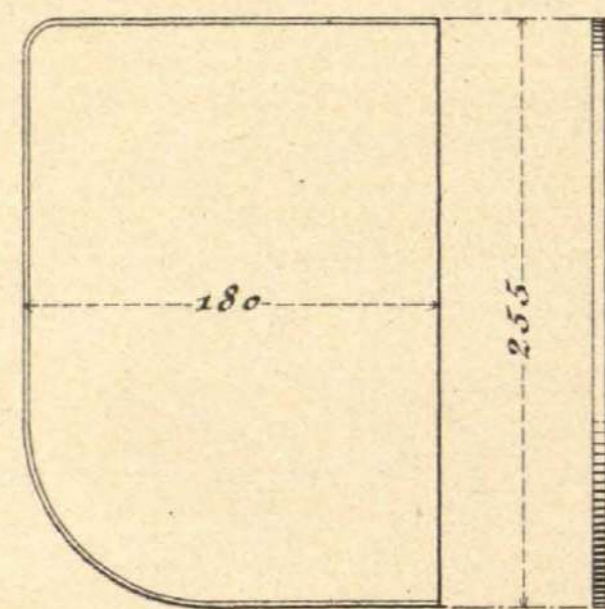

Sobre anca

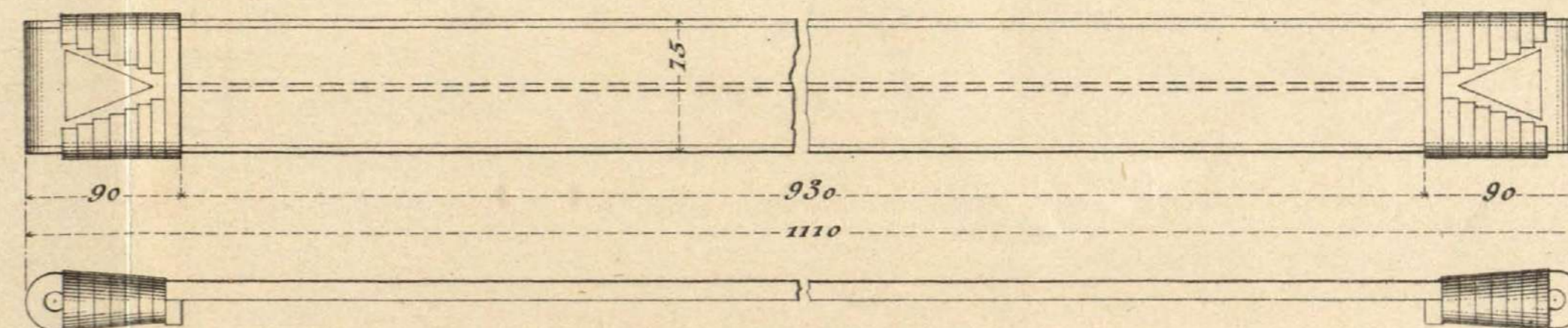



# ATALAJE Md. 1912 Car. Mña.

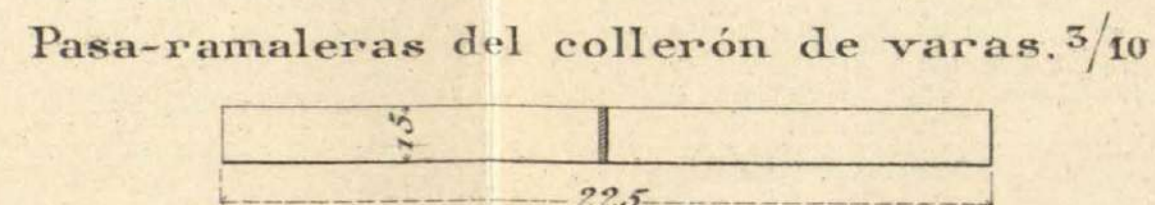
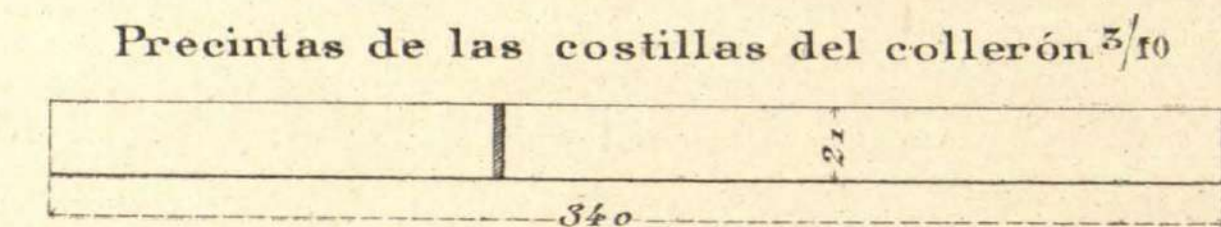
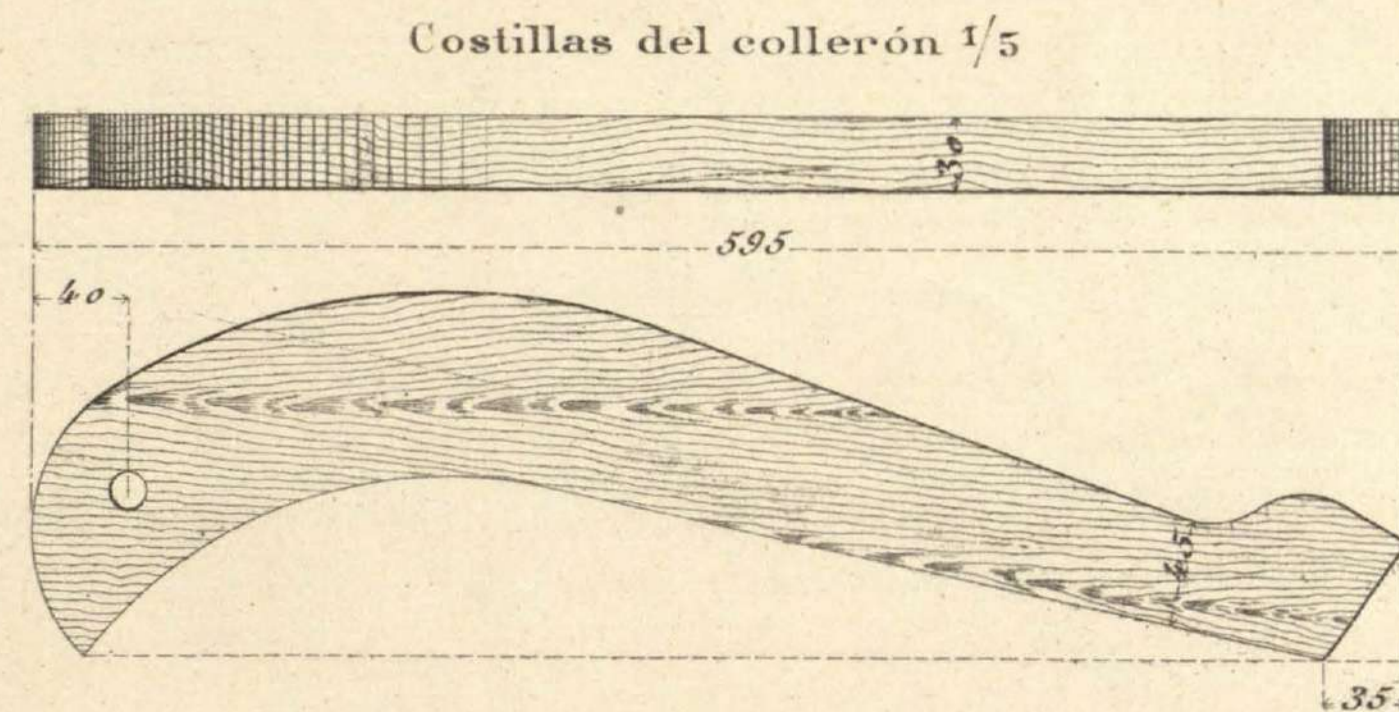
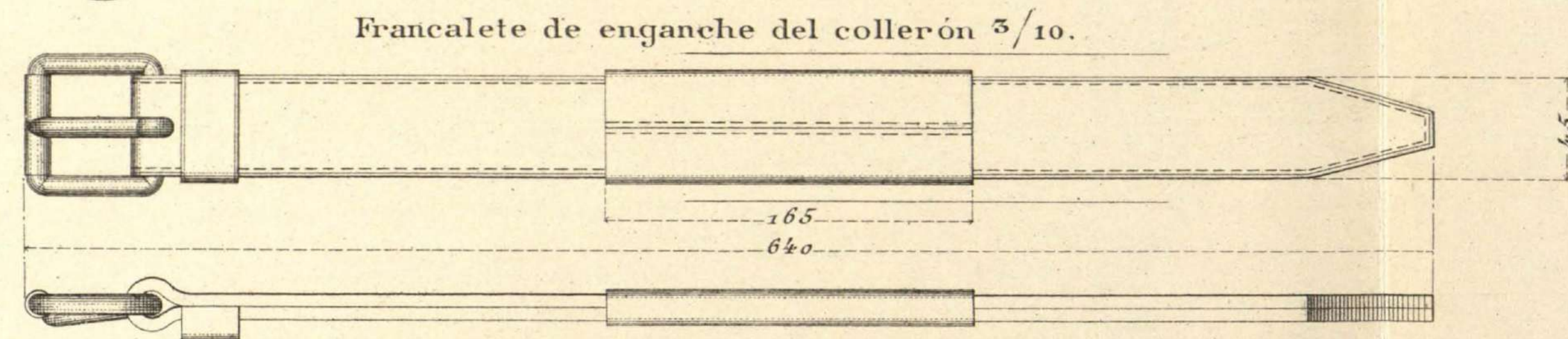
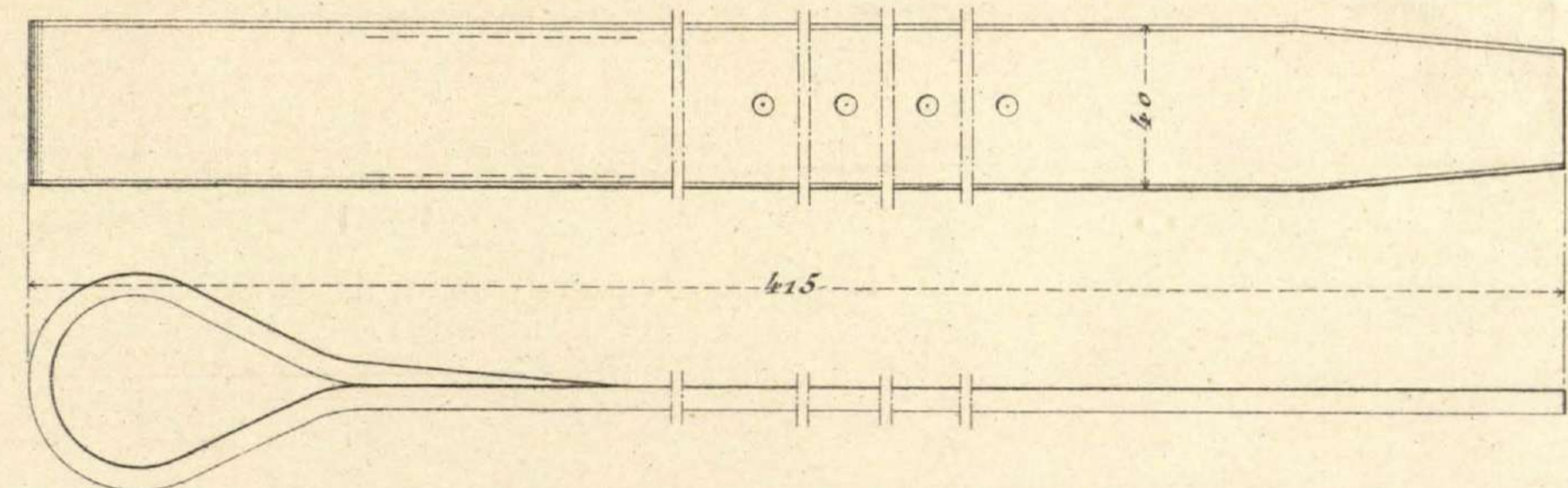
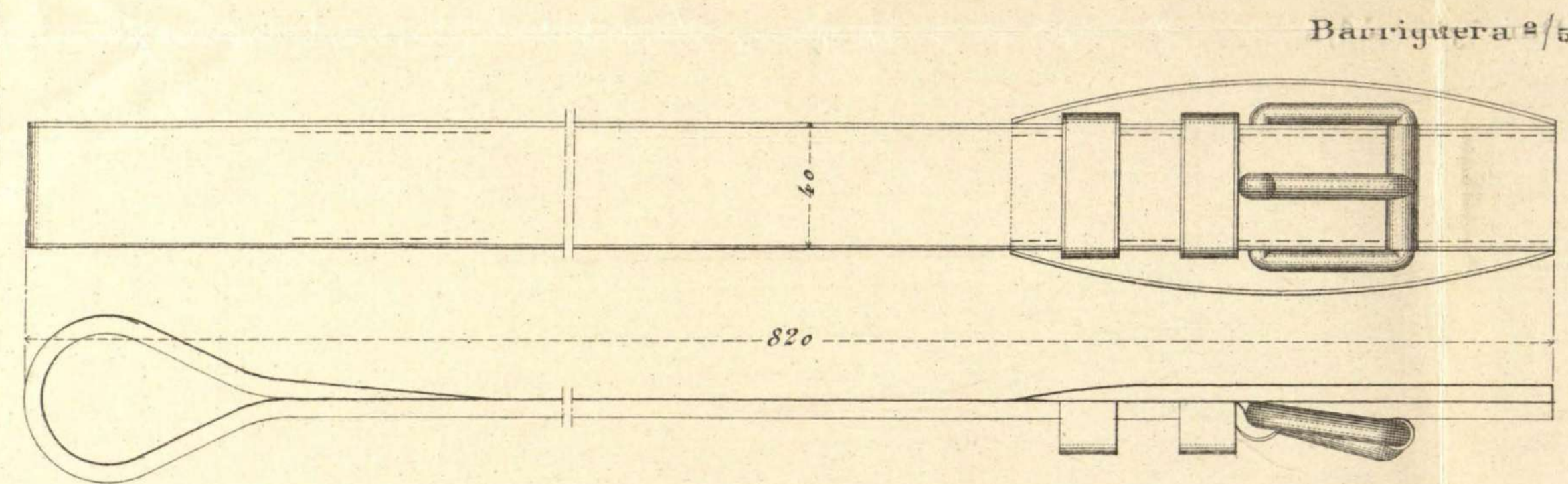
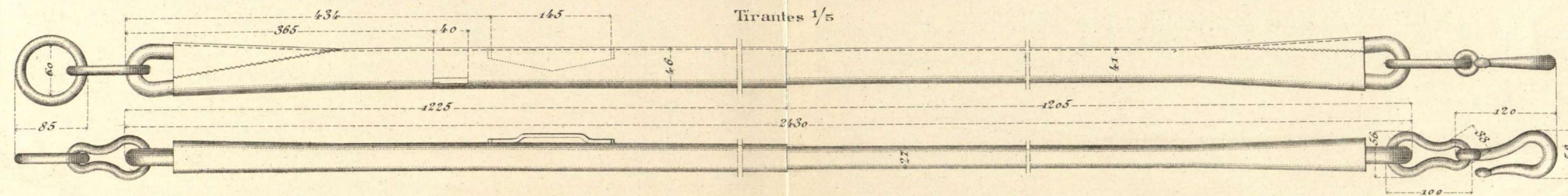
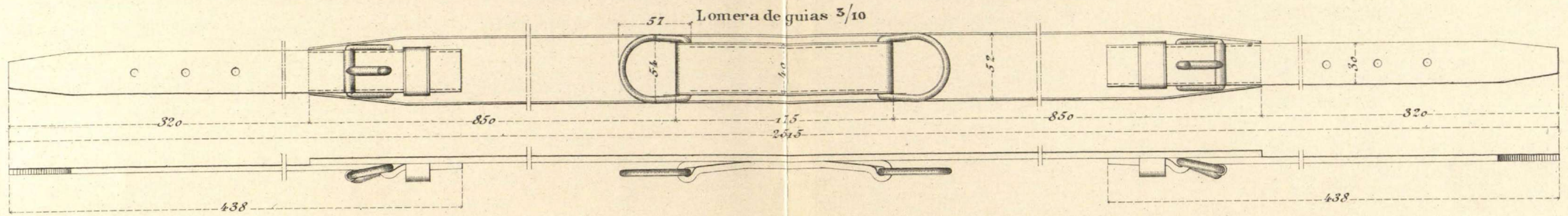

# ATALAJE Md. 1912. Car. Mña.

Llave larga del collarón. (E.=1/3.)

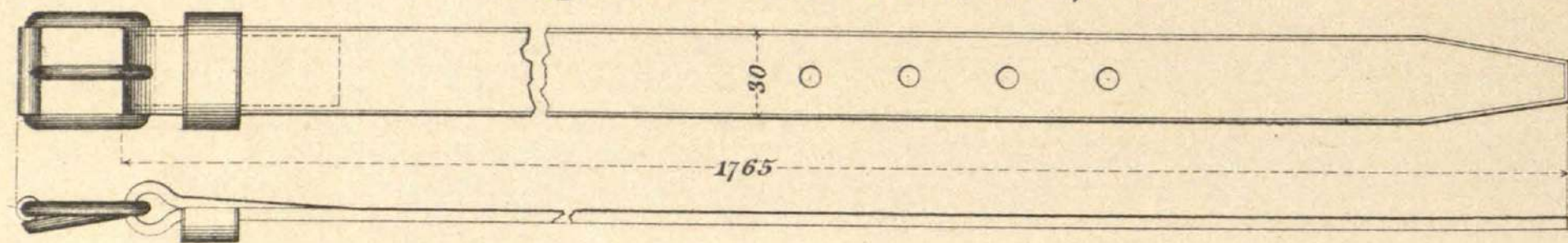

2 Chapas de sujeción del guarda-polvo. (E.=1/2.)

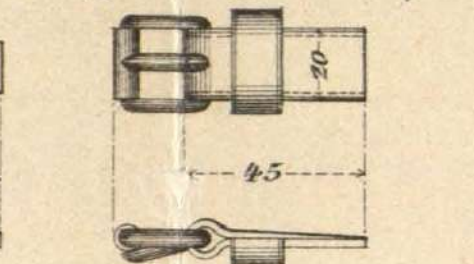

Correa de la llave larga del collarón. (E.=1/3.)

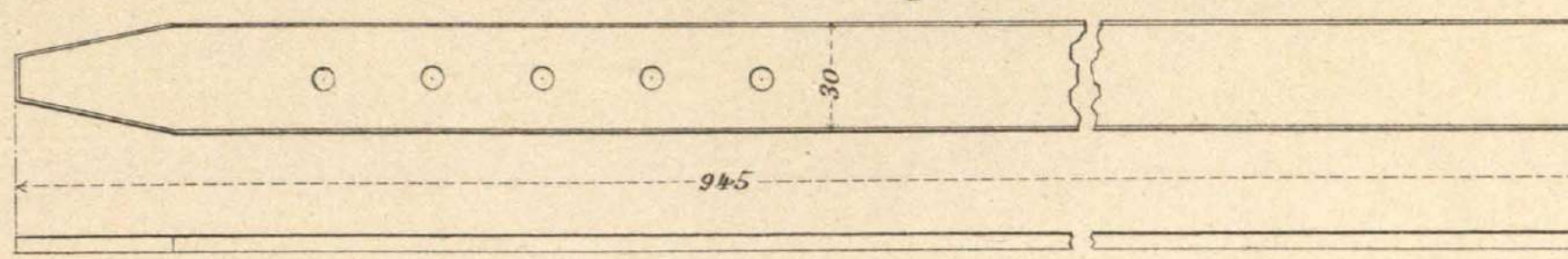

Llave corta del collarón. (E.=1/3.)

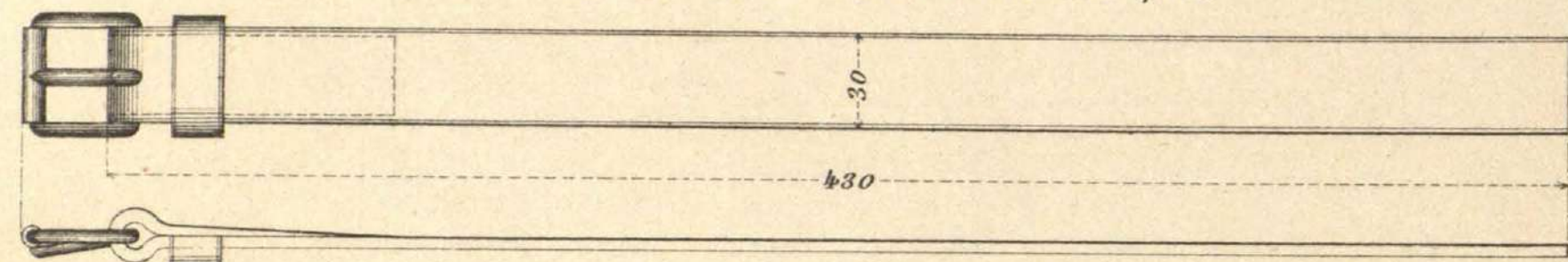

Llave de las costillas del collarón. (E.=1/3.)

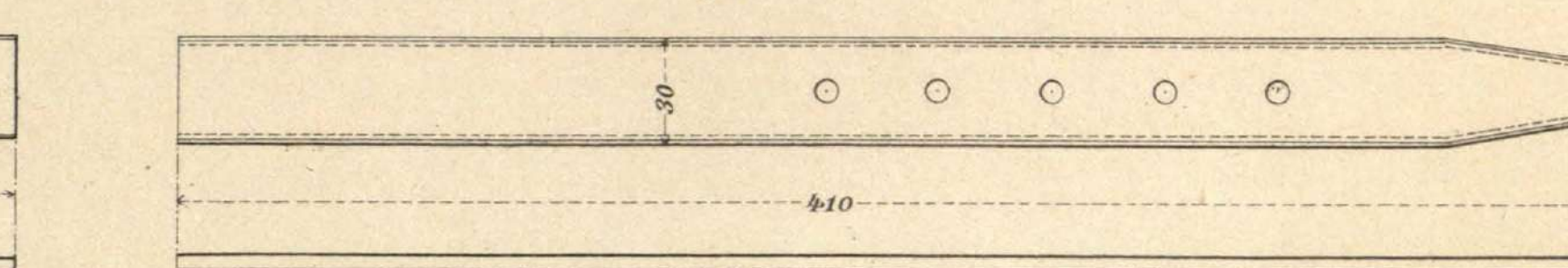
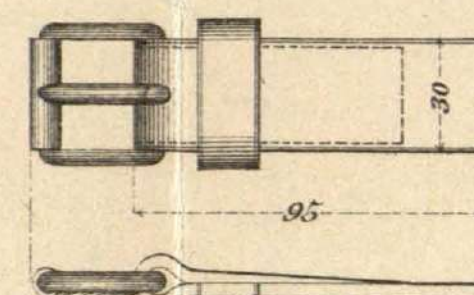

Testera. (E.=1/3.)

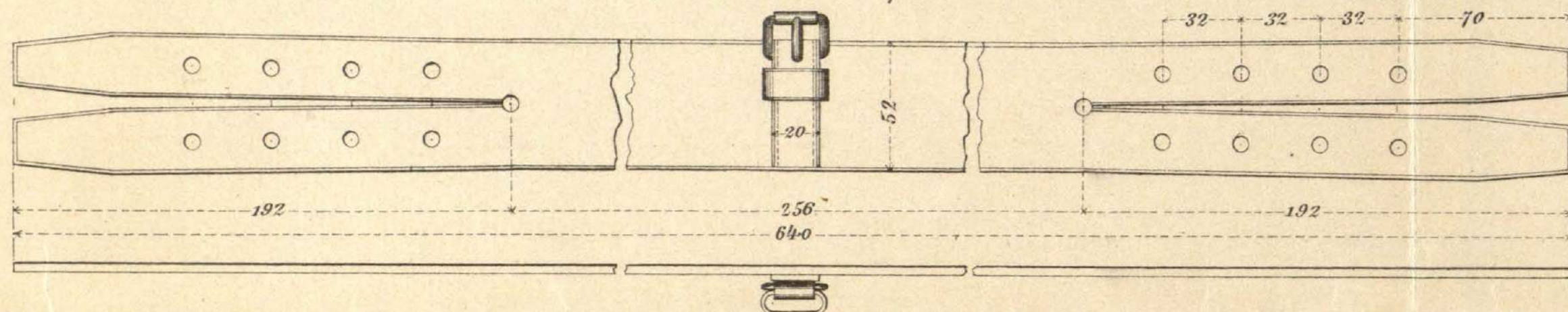

Frontalera. (E.=1/3.)

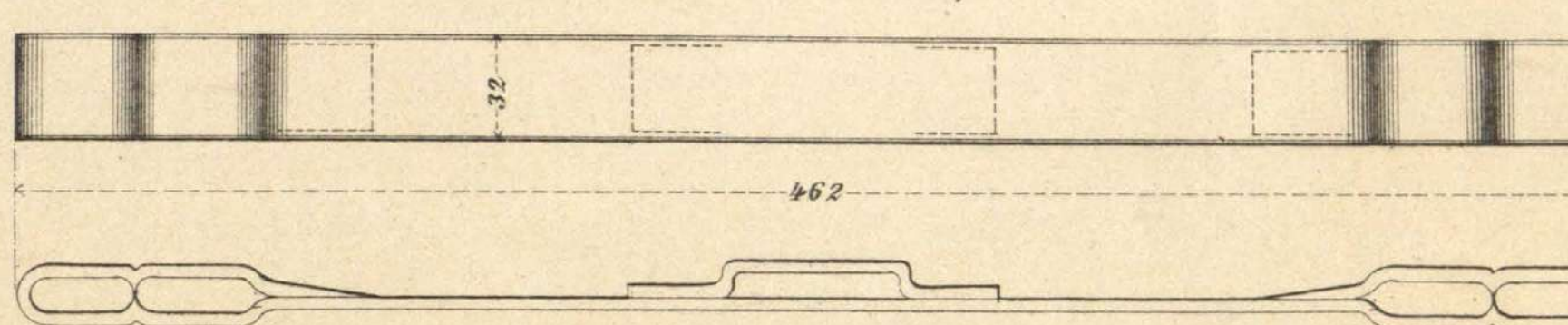

Ahogadero. (E.=1/3.)

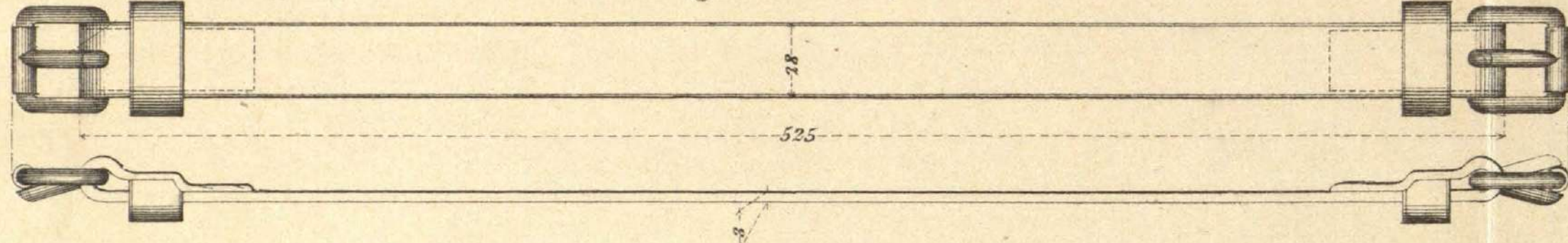

Tijerilla de anteojera. (E.=1/2.)

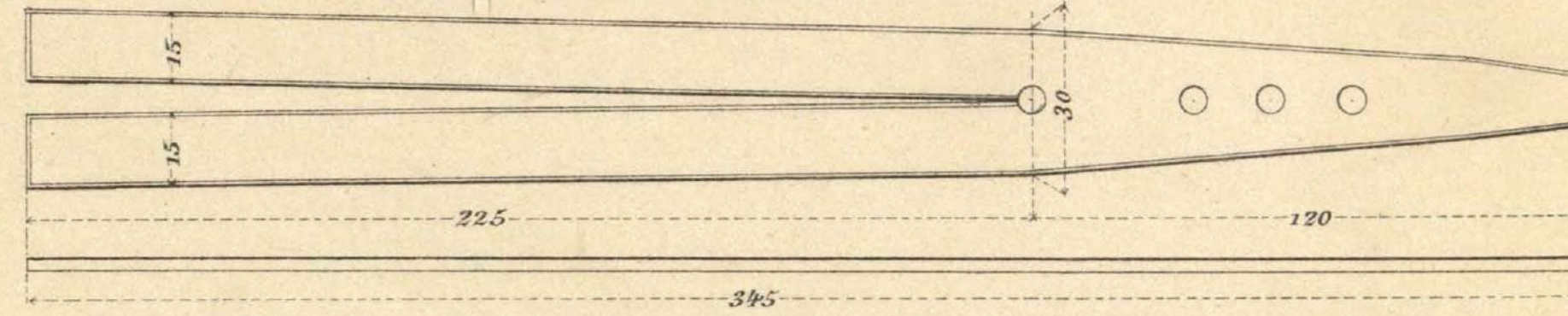

Carrilleras. (E.=1/2.)

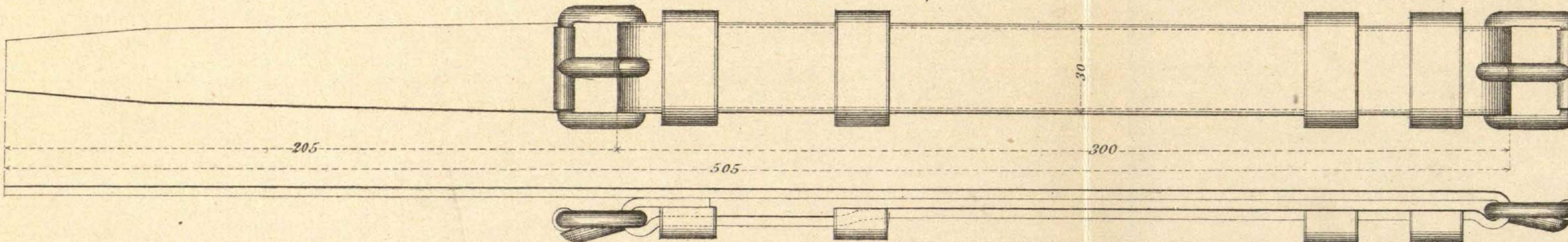

Francalete de suspensión de serreta. (E.=1/2.)

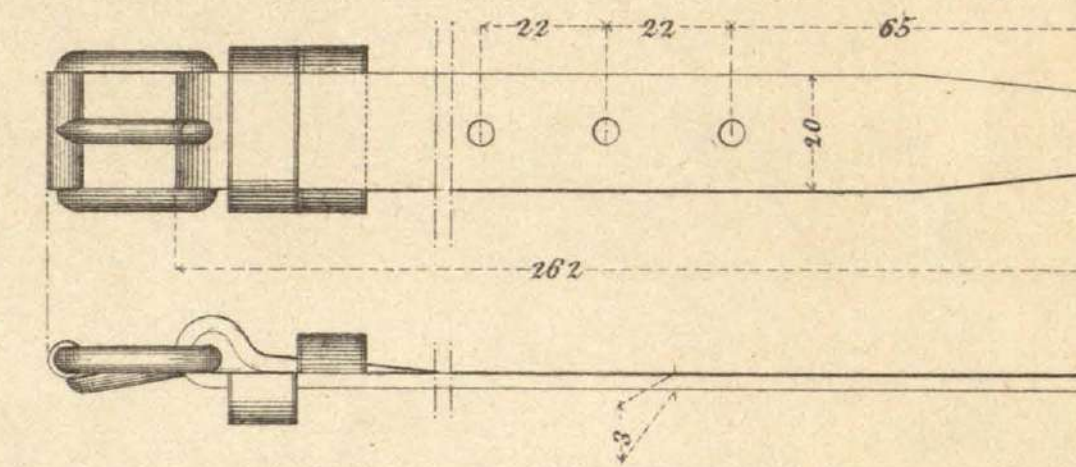

Muserola. (E.=1/3.)

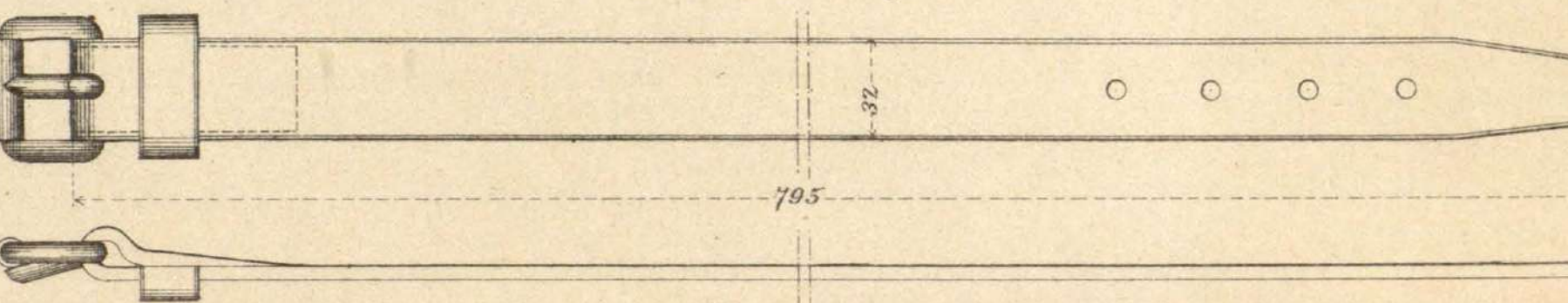

Correa de cara. (E.=1/3.)

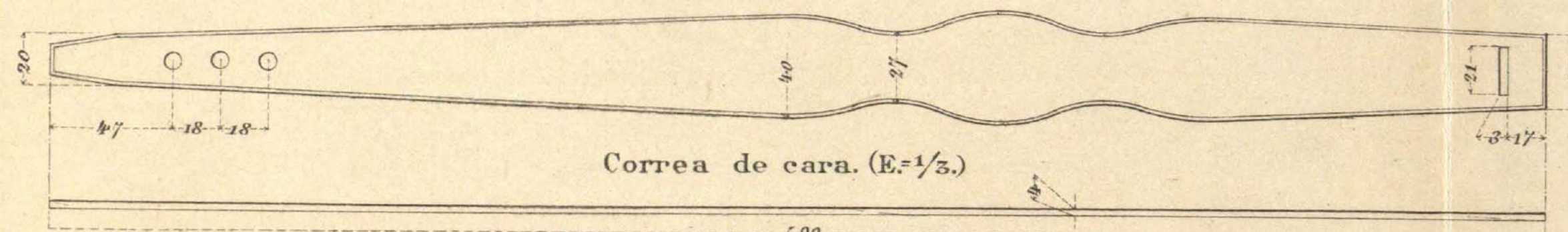



# APARATO PARA ENGARZAR PROYECTILES DE CAMPAÑA MODELO 1914.

Escala  $\frac{4}{10}$ .

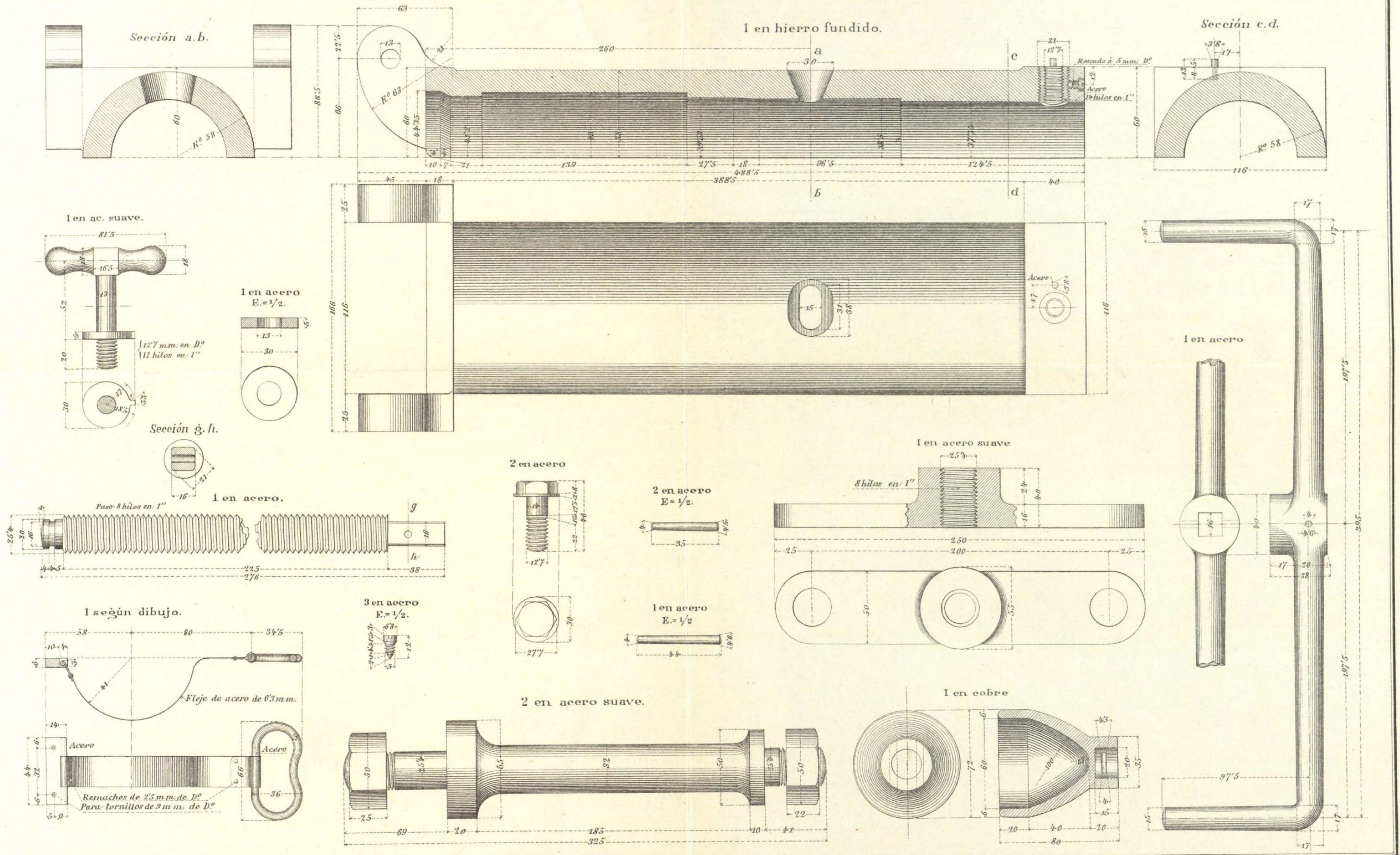

# APARATO PARA ENGARZAR PROYECTILES DE MONTAÑA MODELO 1914

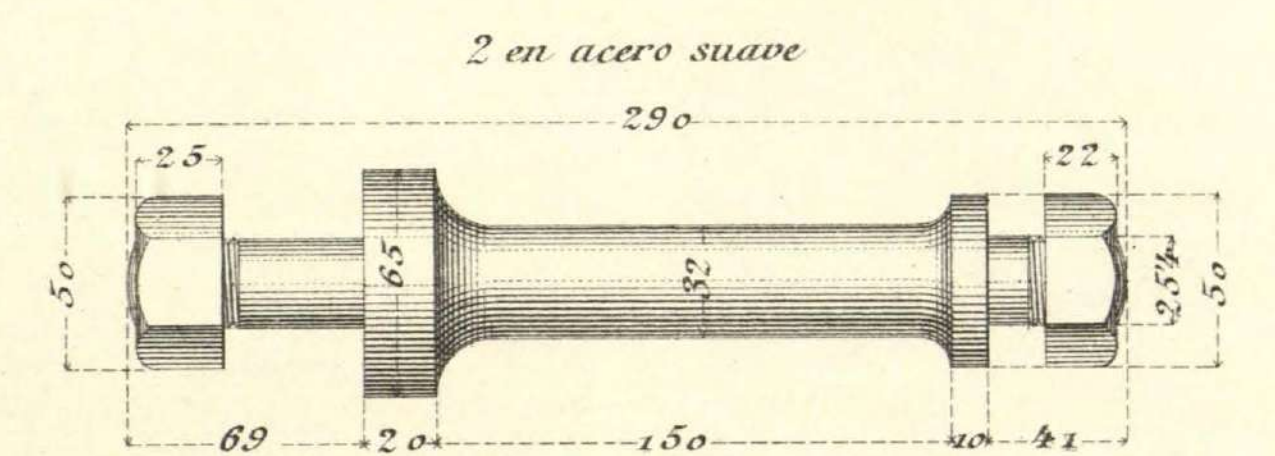
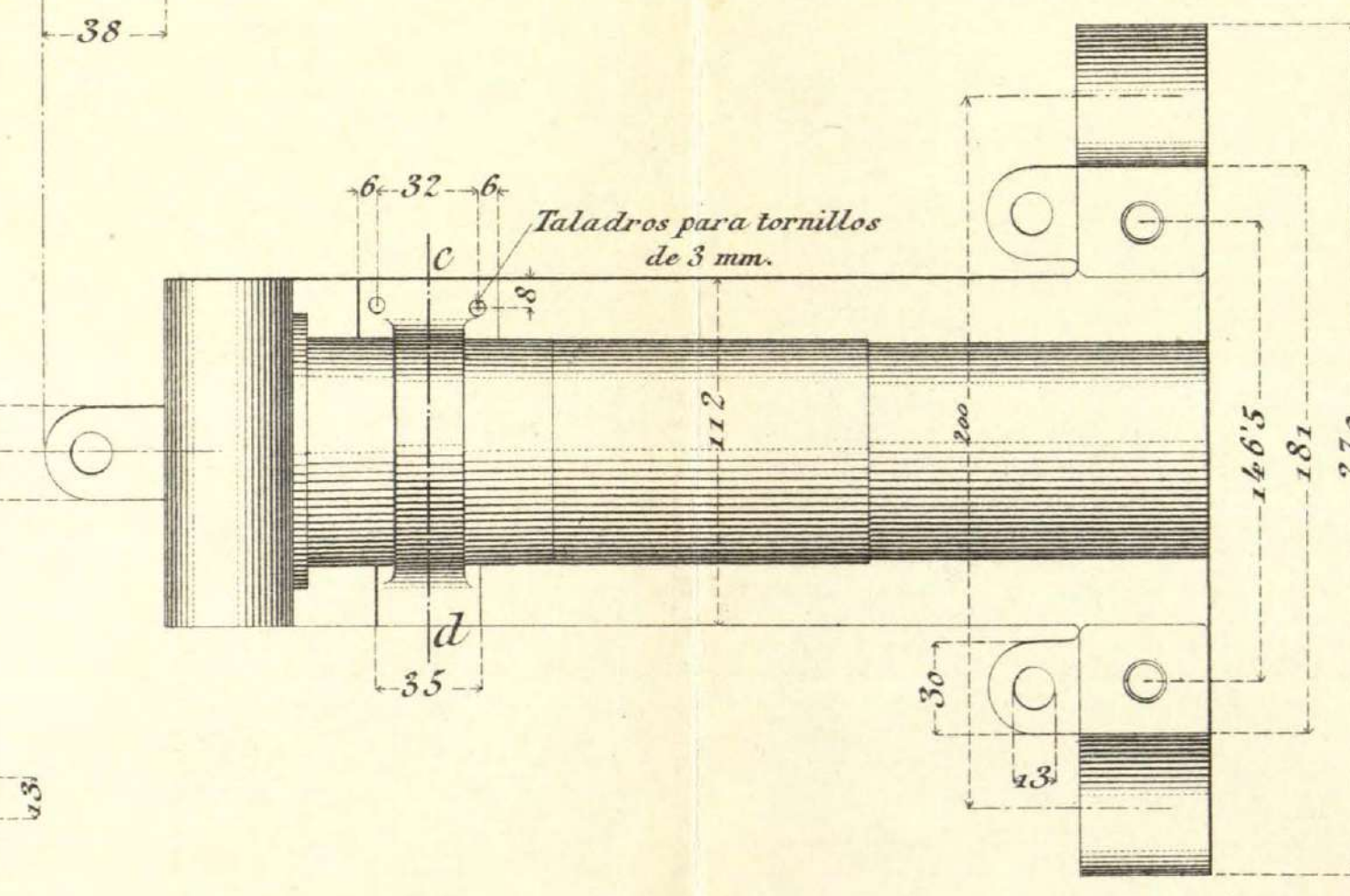
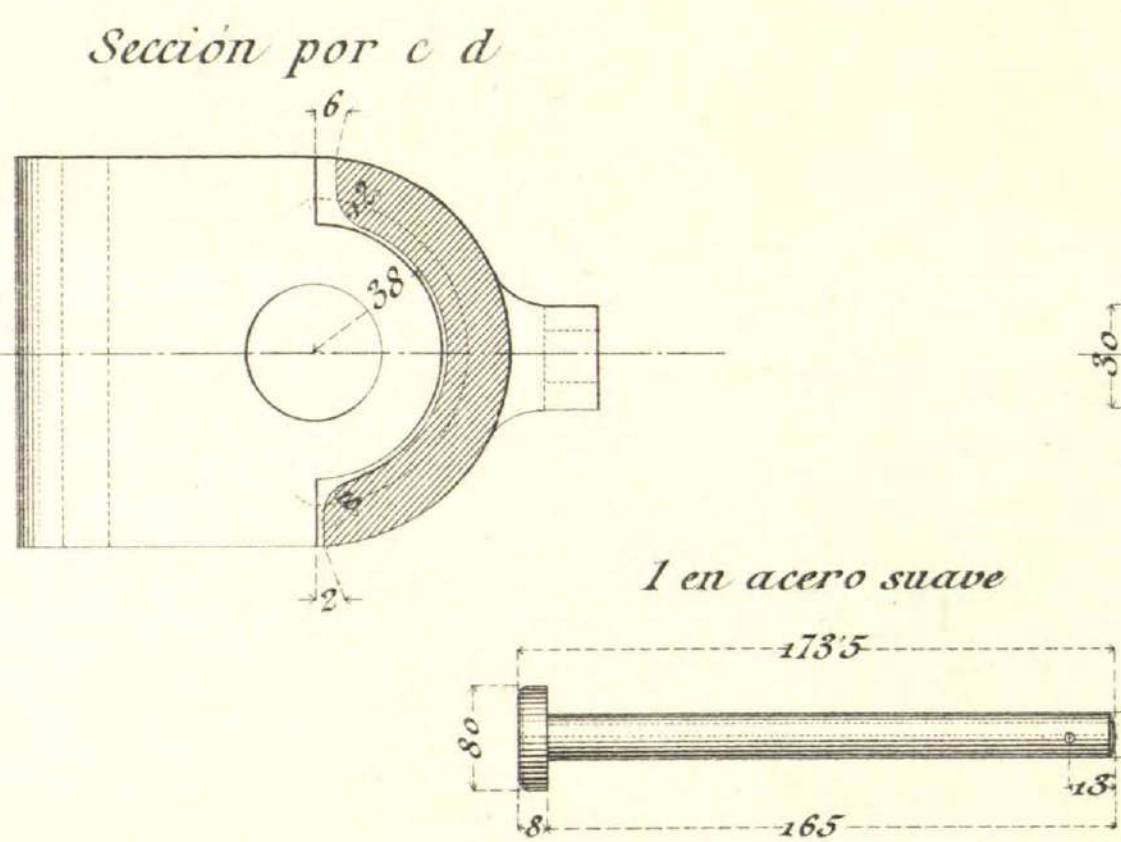
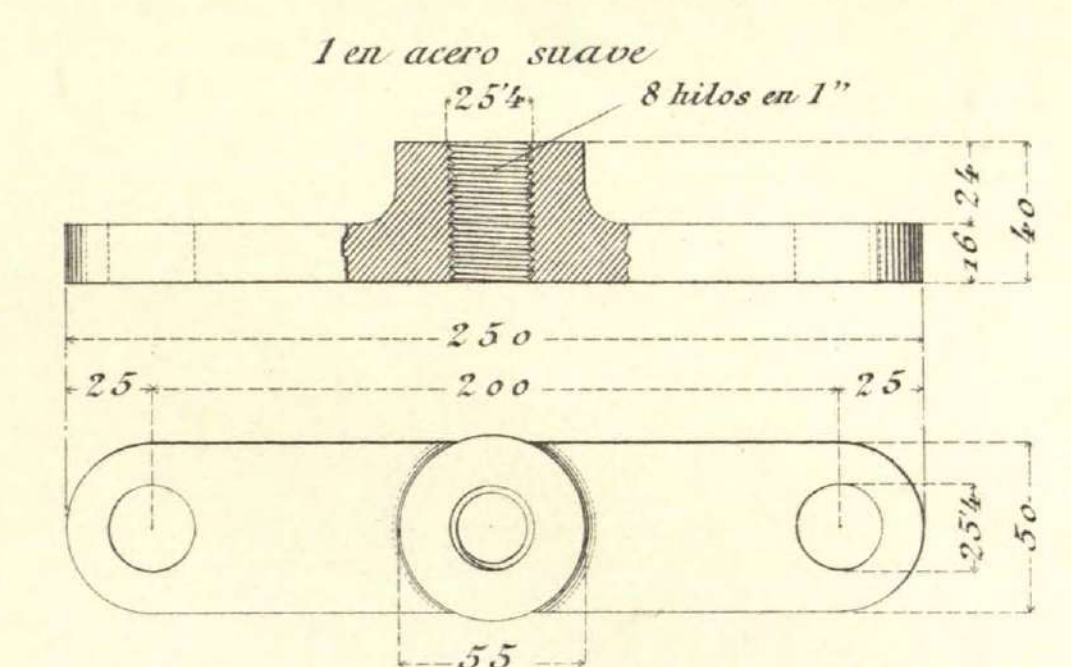
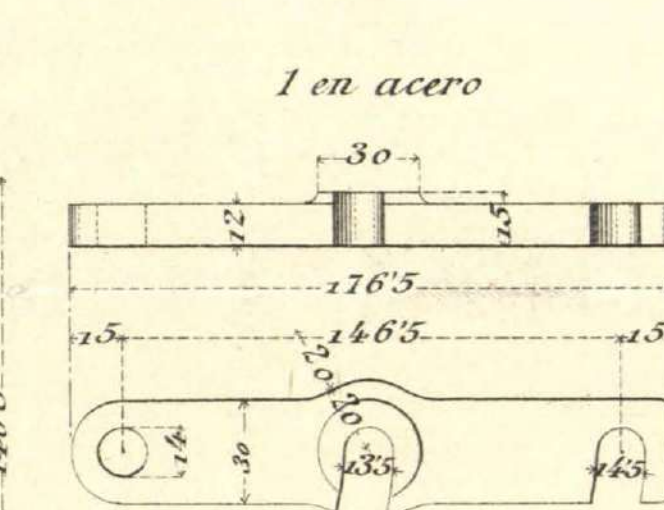
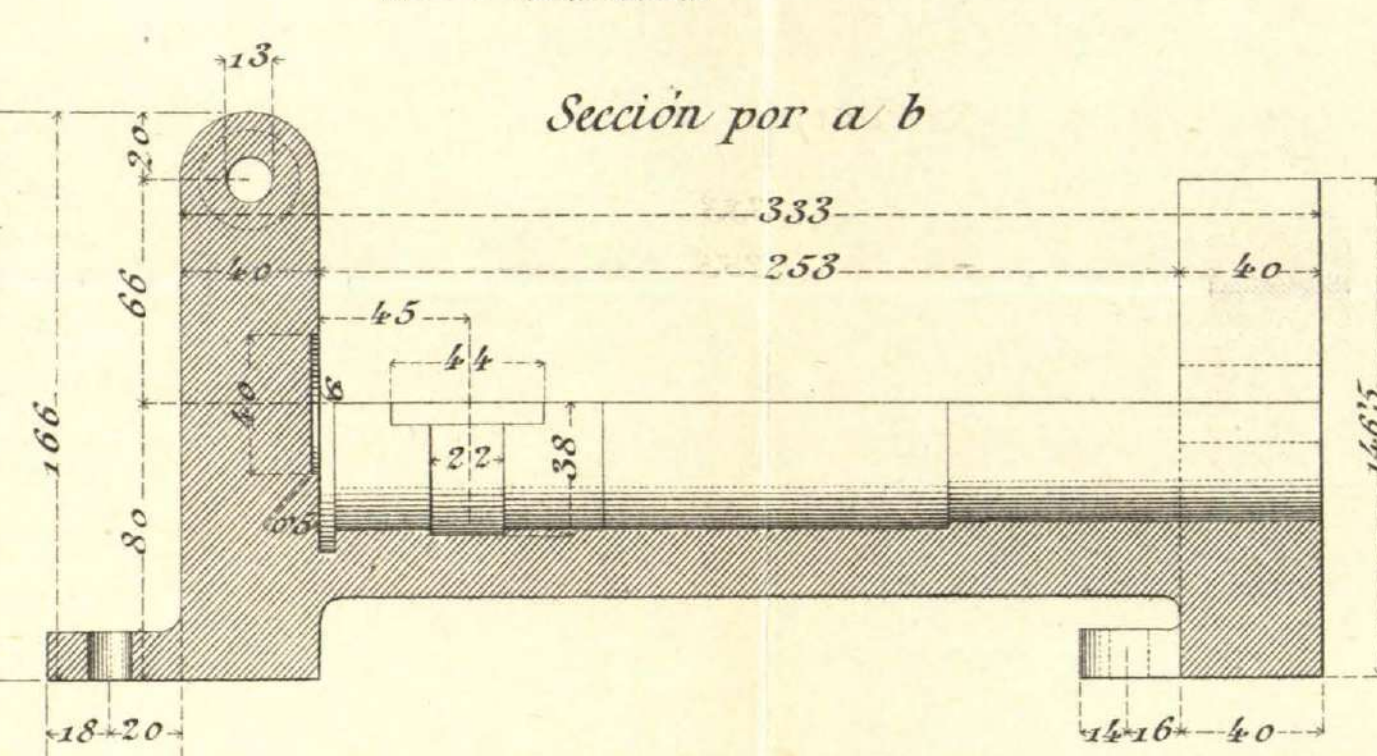
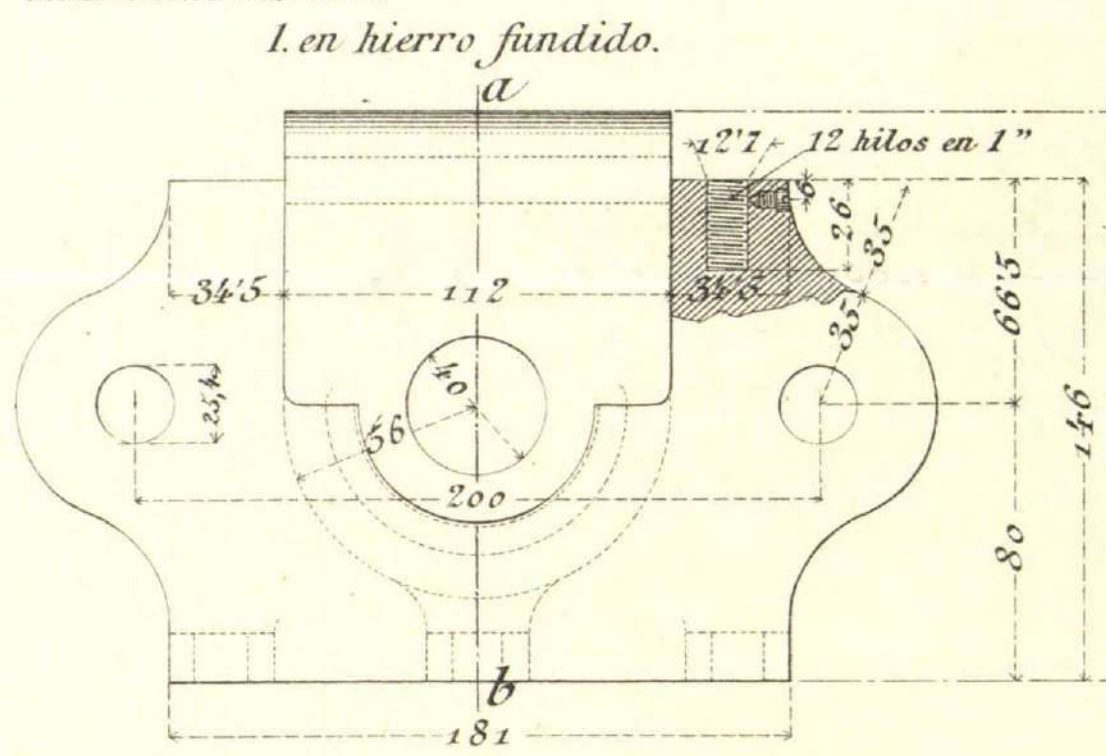
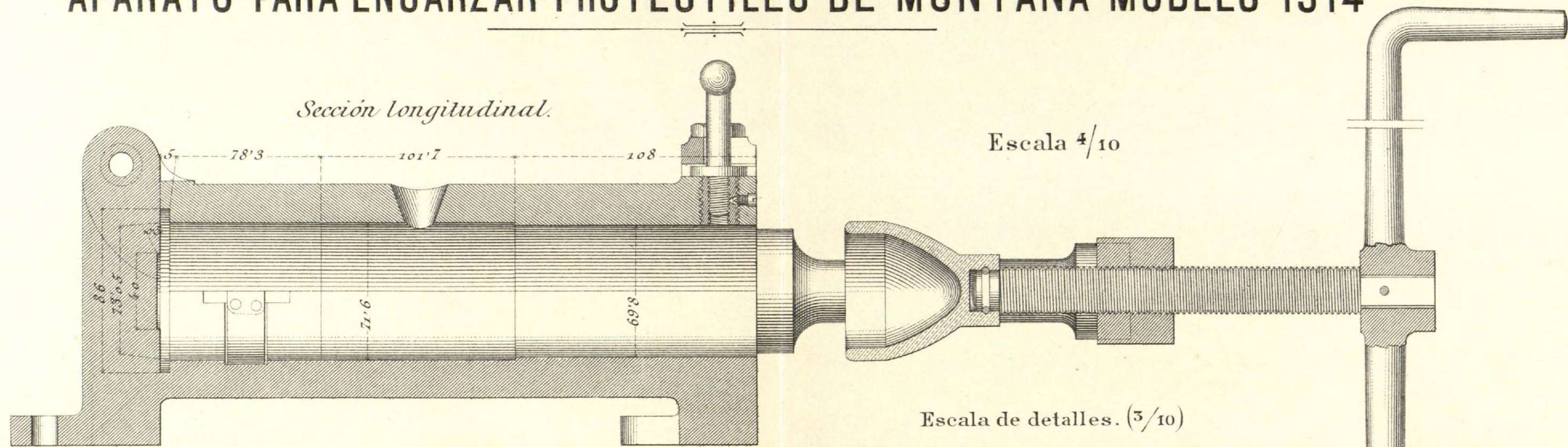



# COLLERON PARA ATALAJE DE CAMPAÑA Md. 1915.

Vista anterior

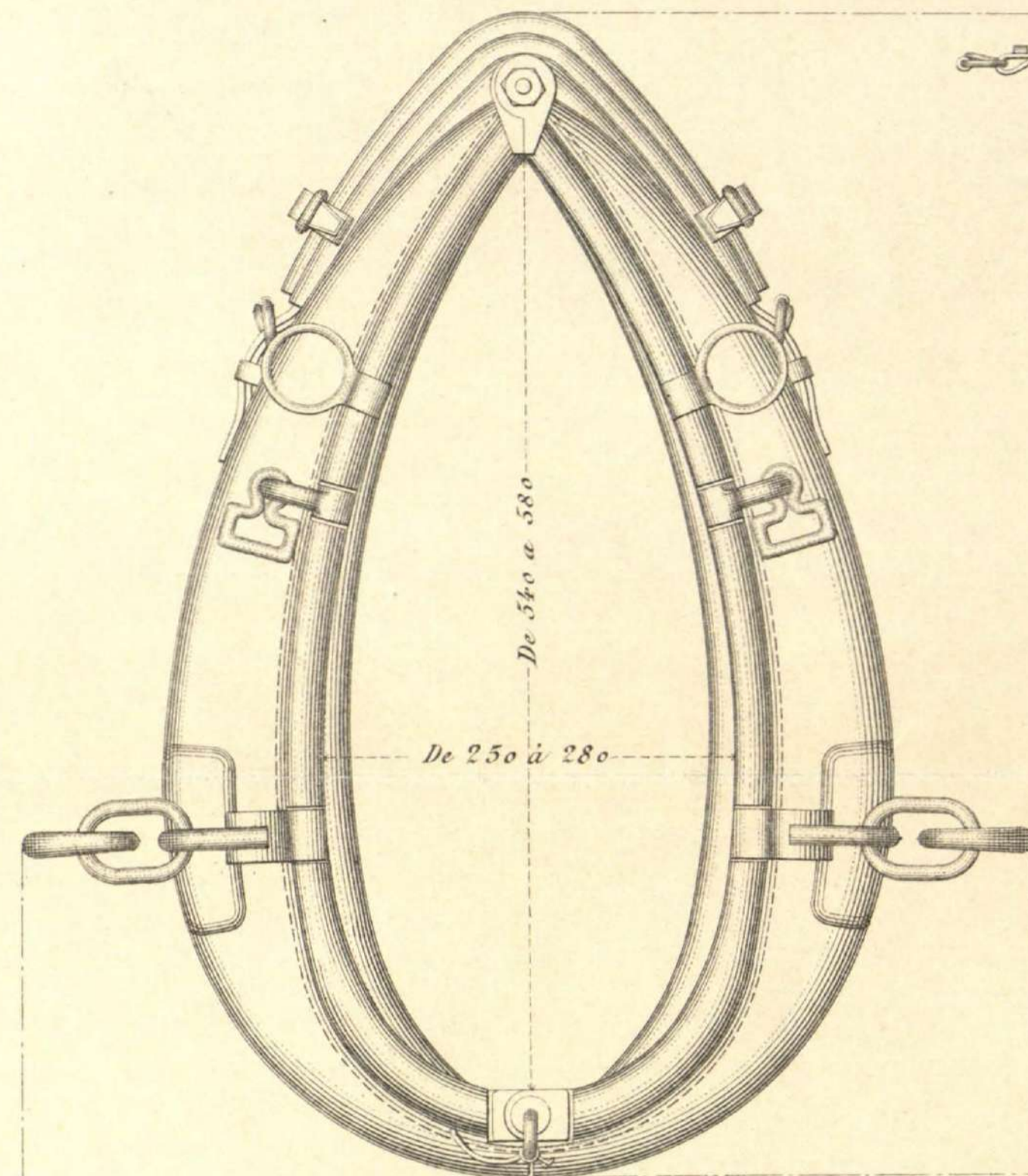

Vista de costado.

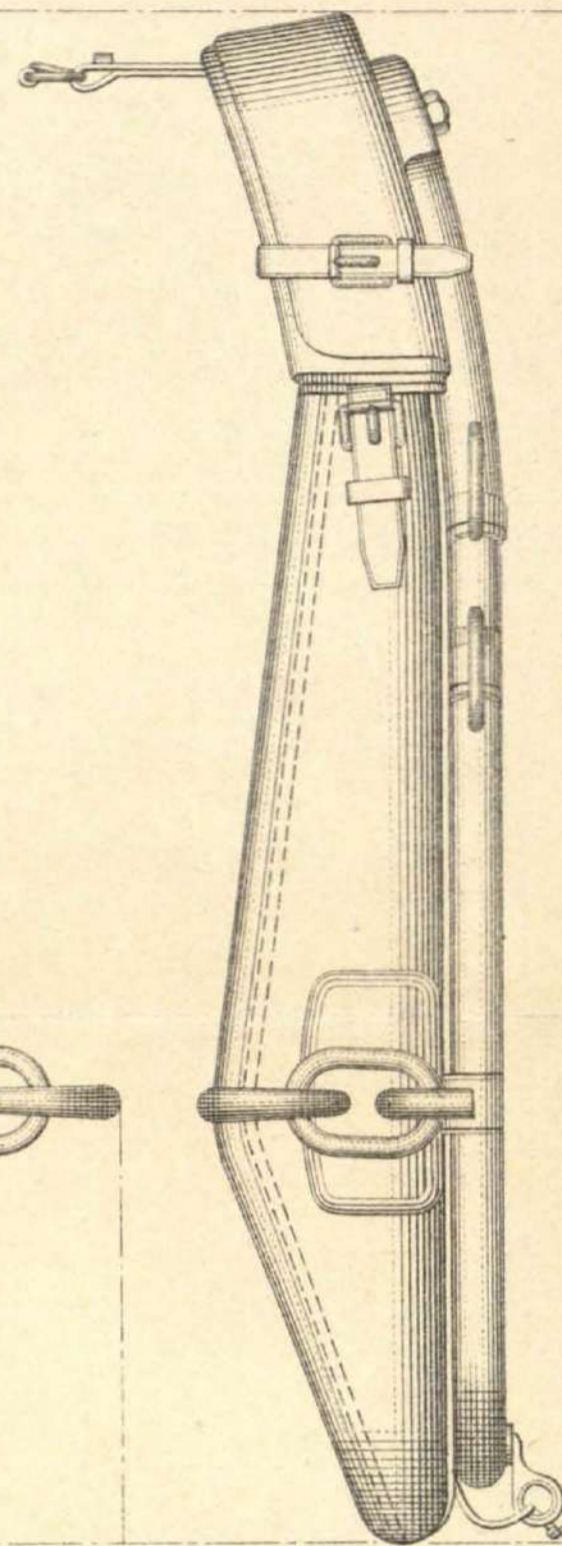

Escala 1/5

Vista posterior.

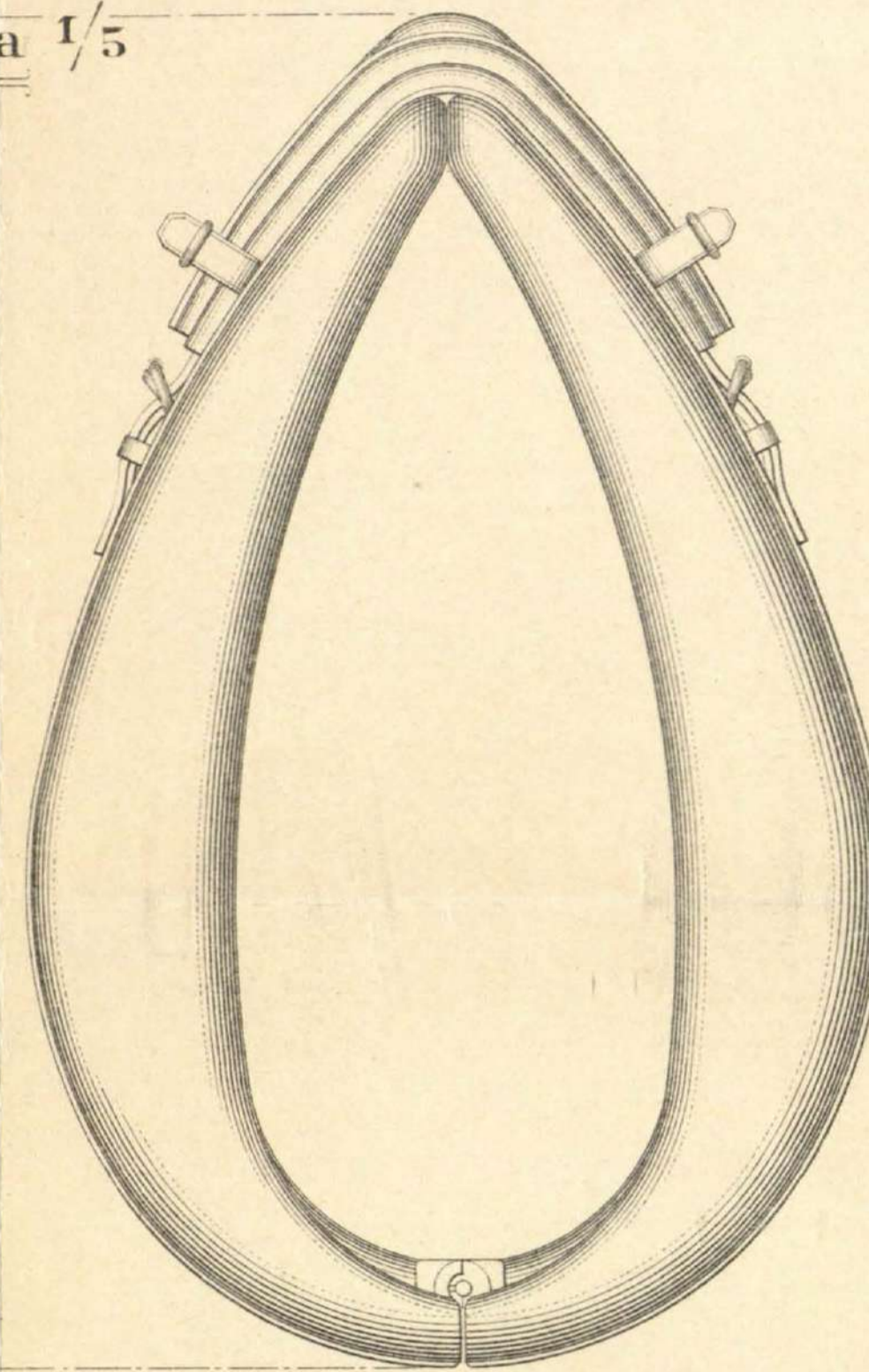

Monterilla

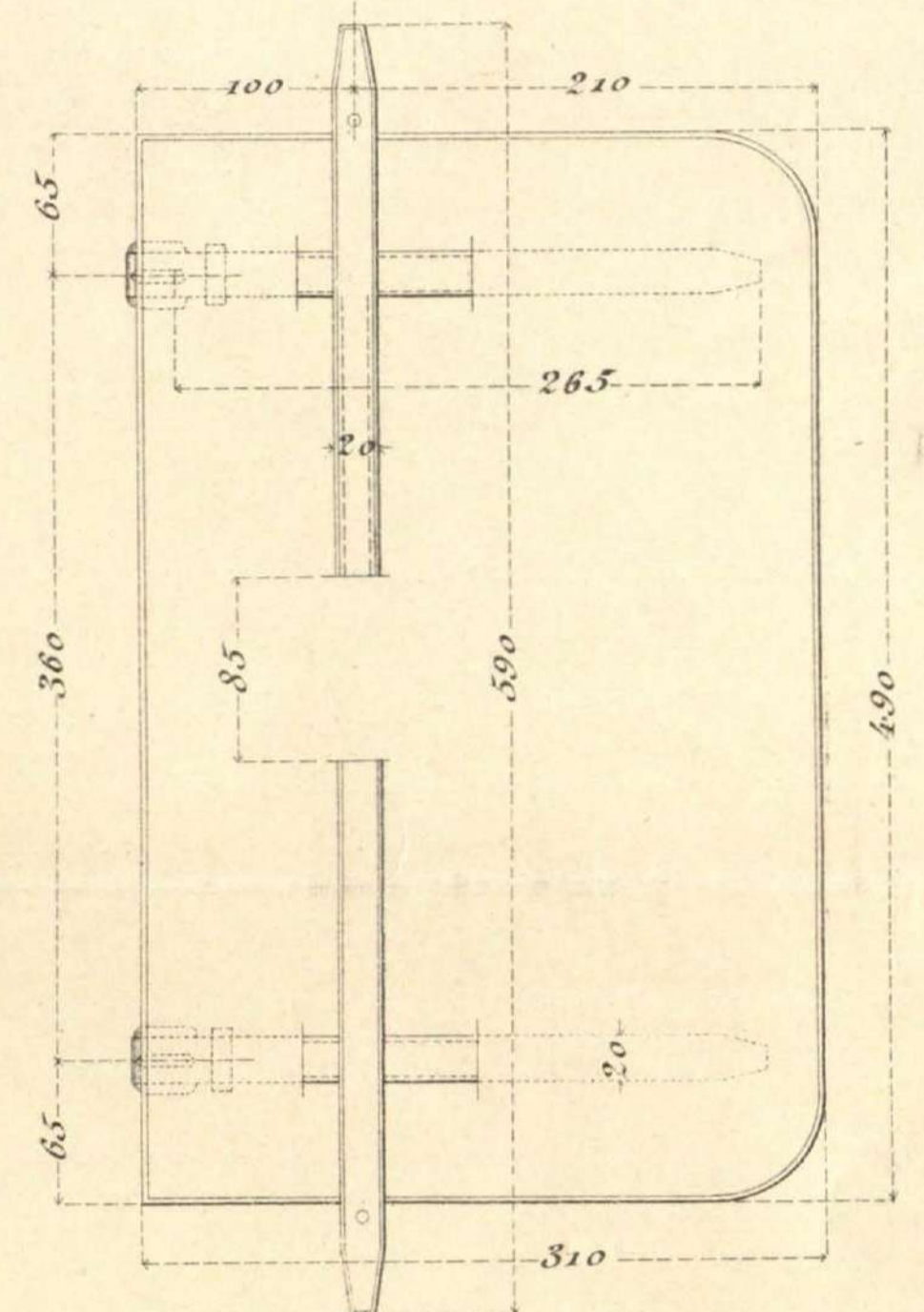

Vista horizontal.

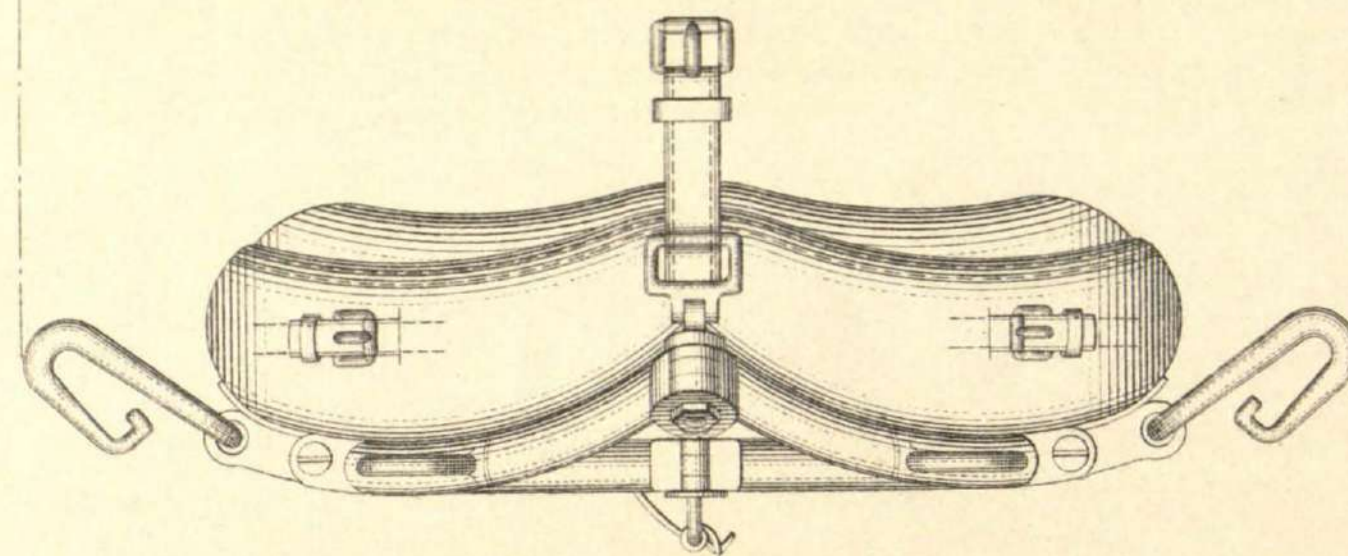

1 Cuerpo de la monterilla

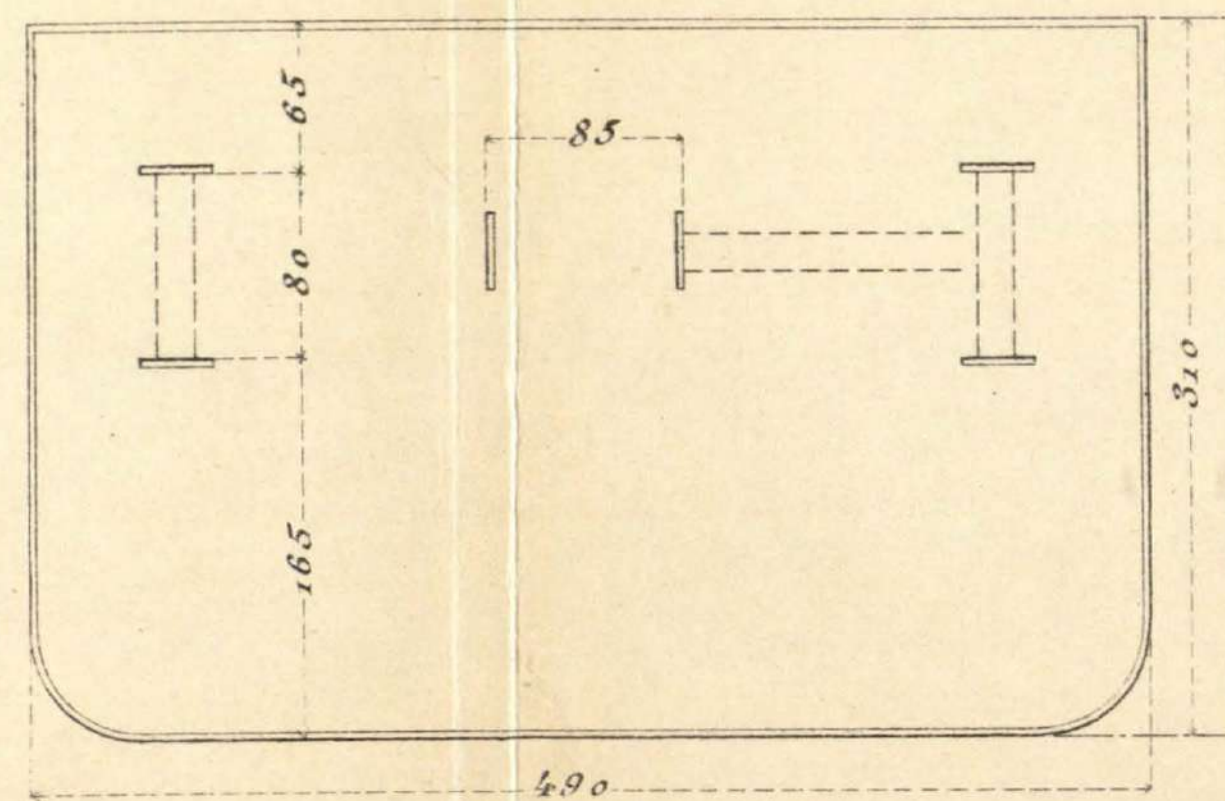

1 Punta para fijar la monterilla.

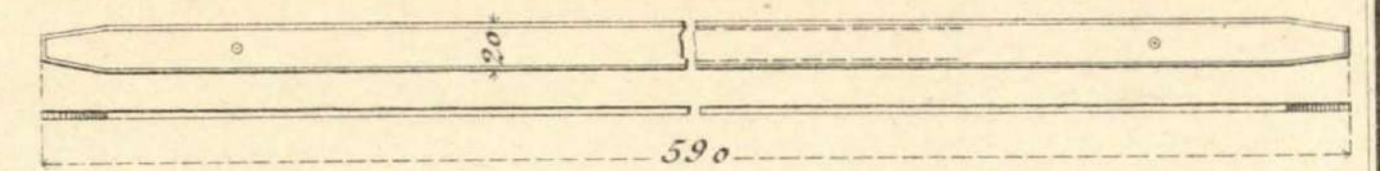

2 Francaletes

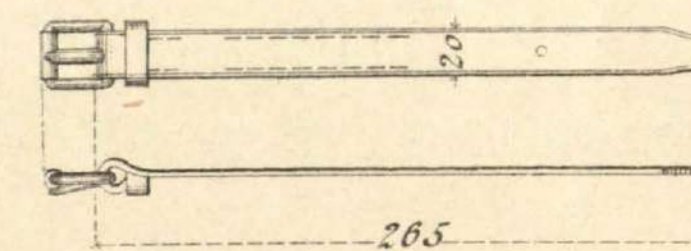

1 Dragona

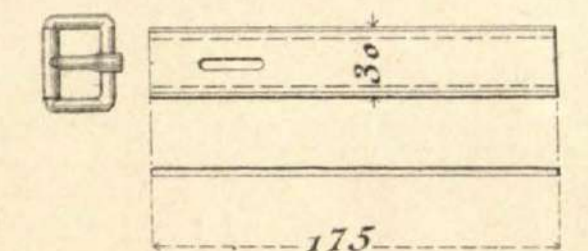

# COLLERÓN PARA ATALAJE DE CAMPAÑA MD. 1915.

Escala 1/5.

1 Cuerpo. (Paja de centeno.)

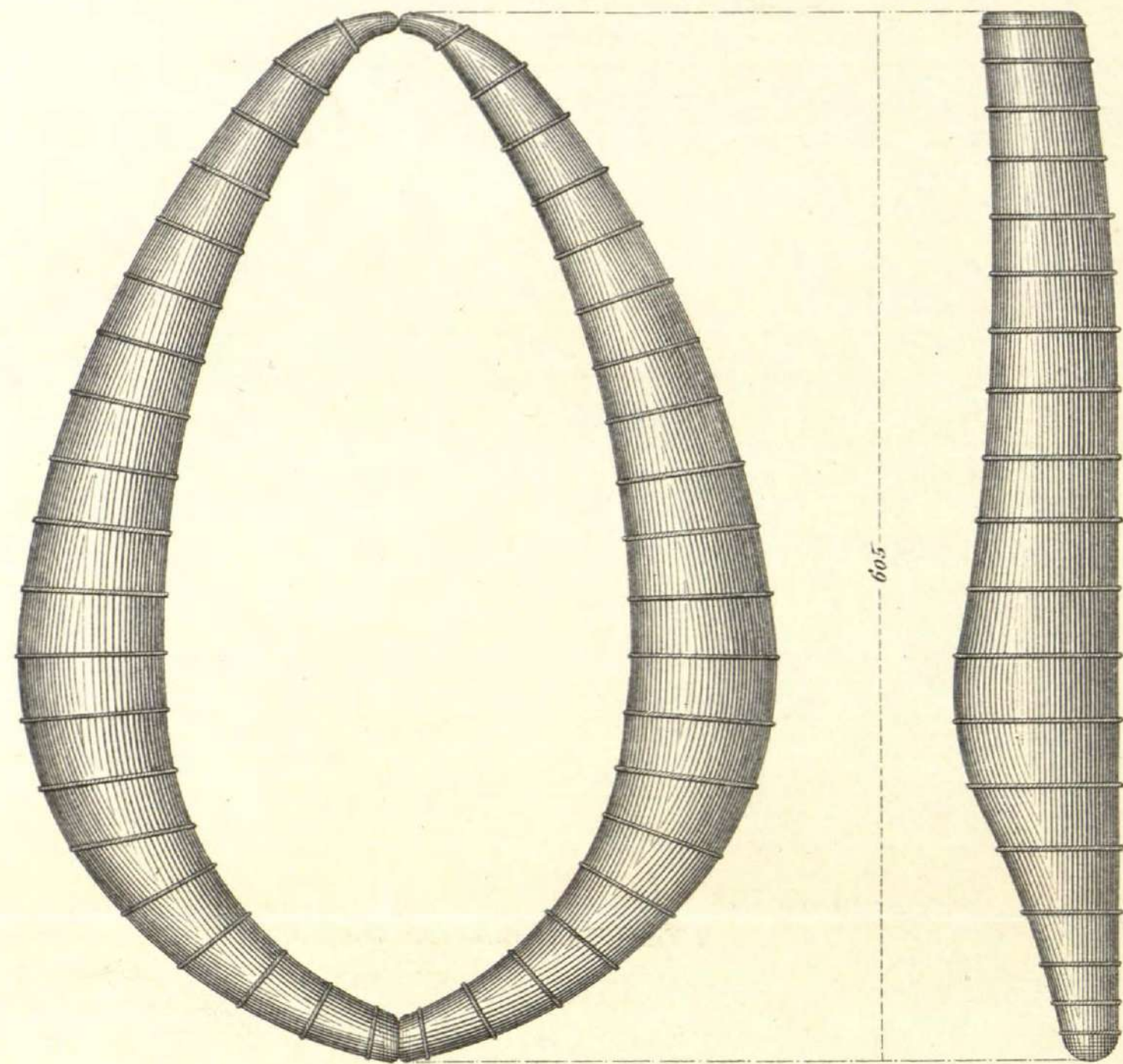

2 Calzones. (Becerro castellano.)

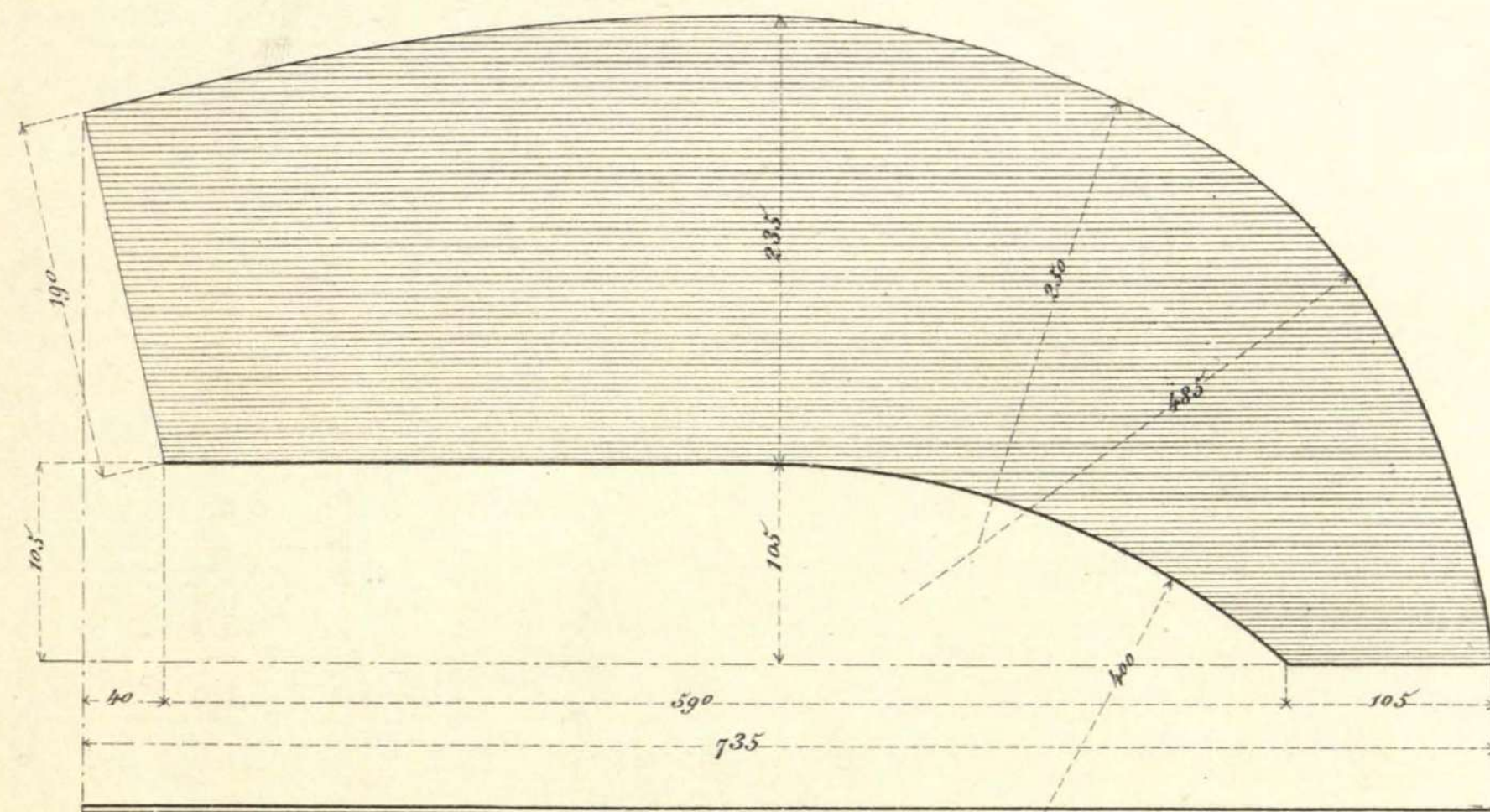

2 Rivetes de las faldillas.



2 Faldillas. (Cuero color avellana.)

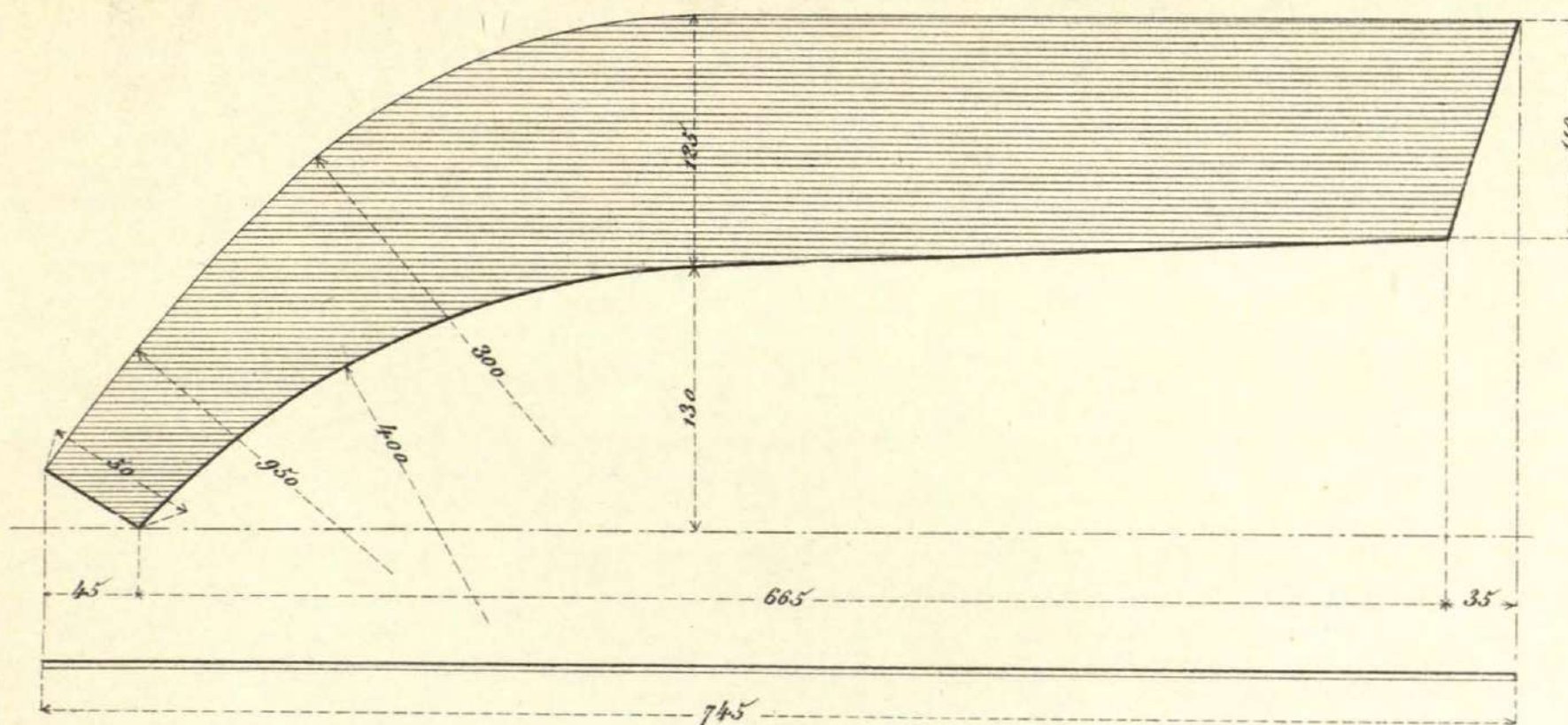

2 Tirantes. (Becerro castellano.)

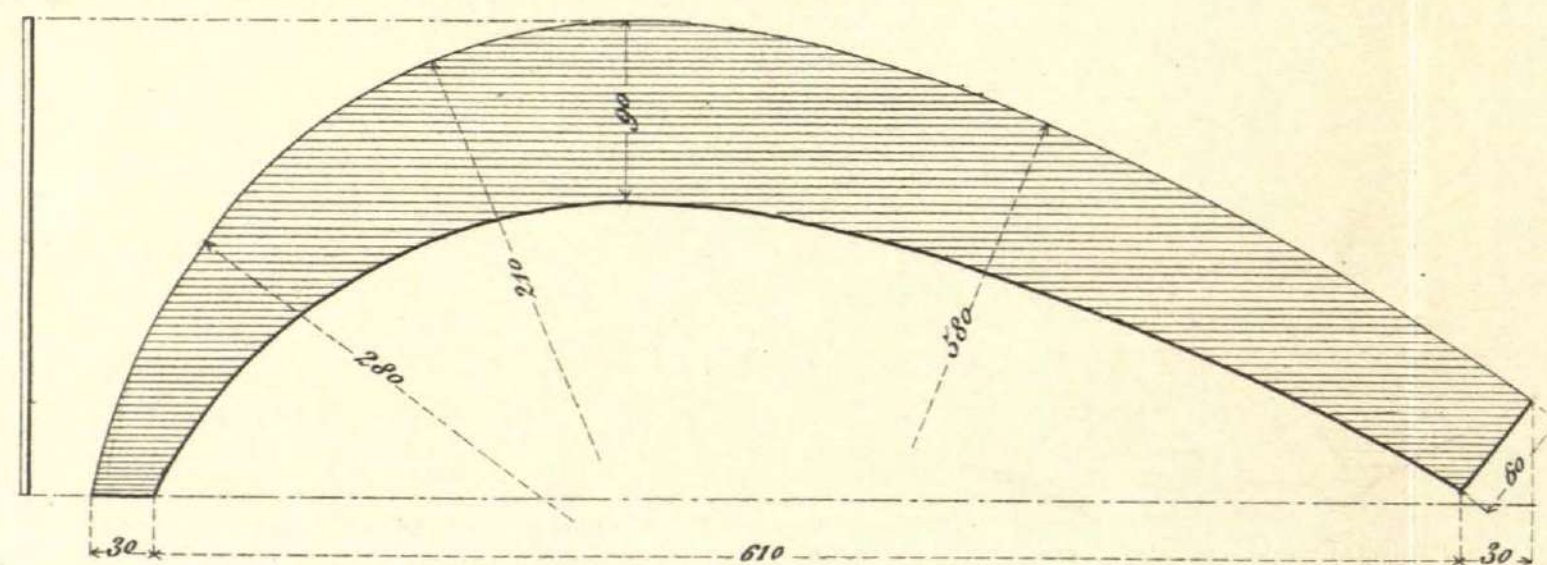

2 Chapas de faldilla.

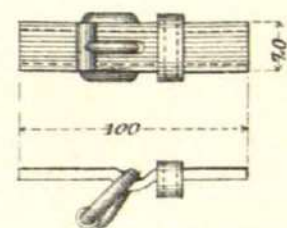

Forros del tubo. (Cuero color avellana.)

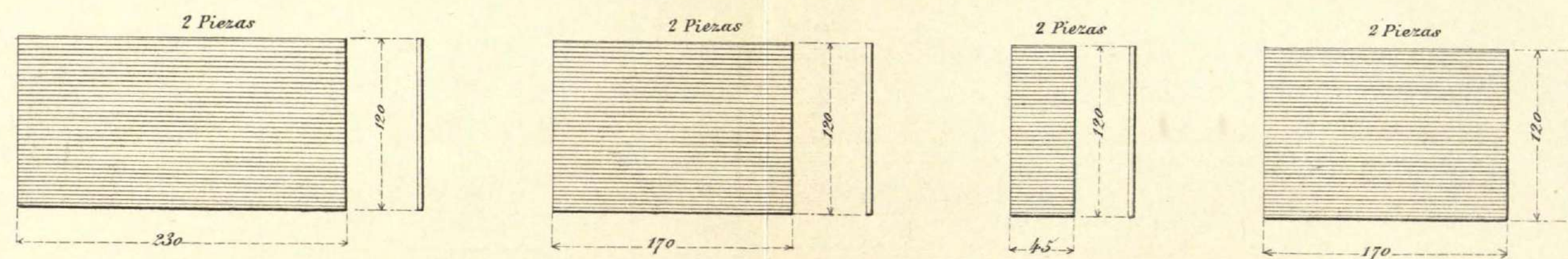

Unión de las faldillas

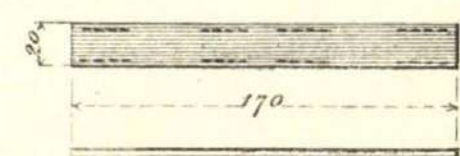

2 Rozaderos de los ganchos

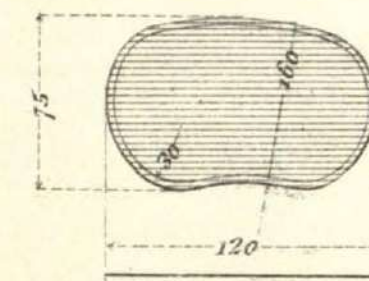





### EQUIPO Y MONTURA PARA LOS REGIMIENTOS MONTADOS DEL ARMA DE ARTILLERIA Md. 1914.

Equipo de plaza montada guías y cuartas

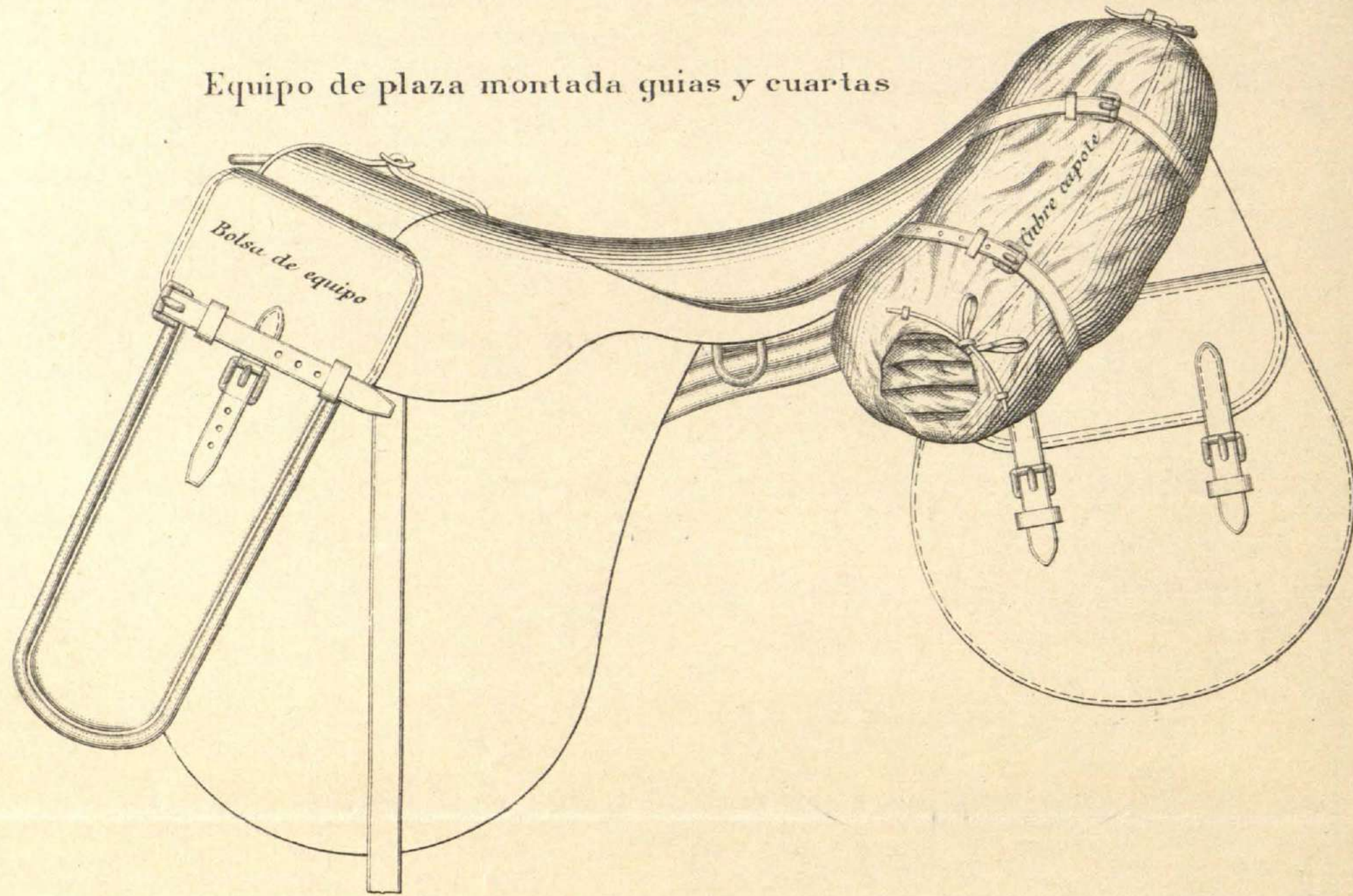

Equipo de caballo de silla de tronco.

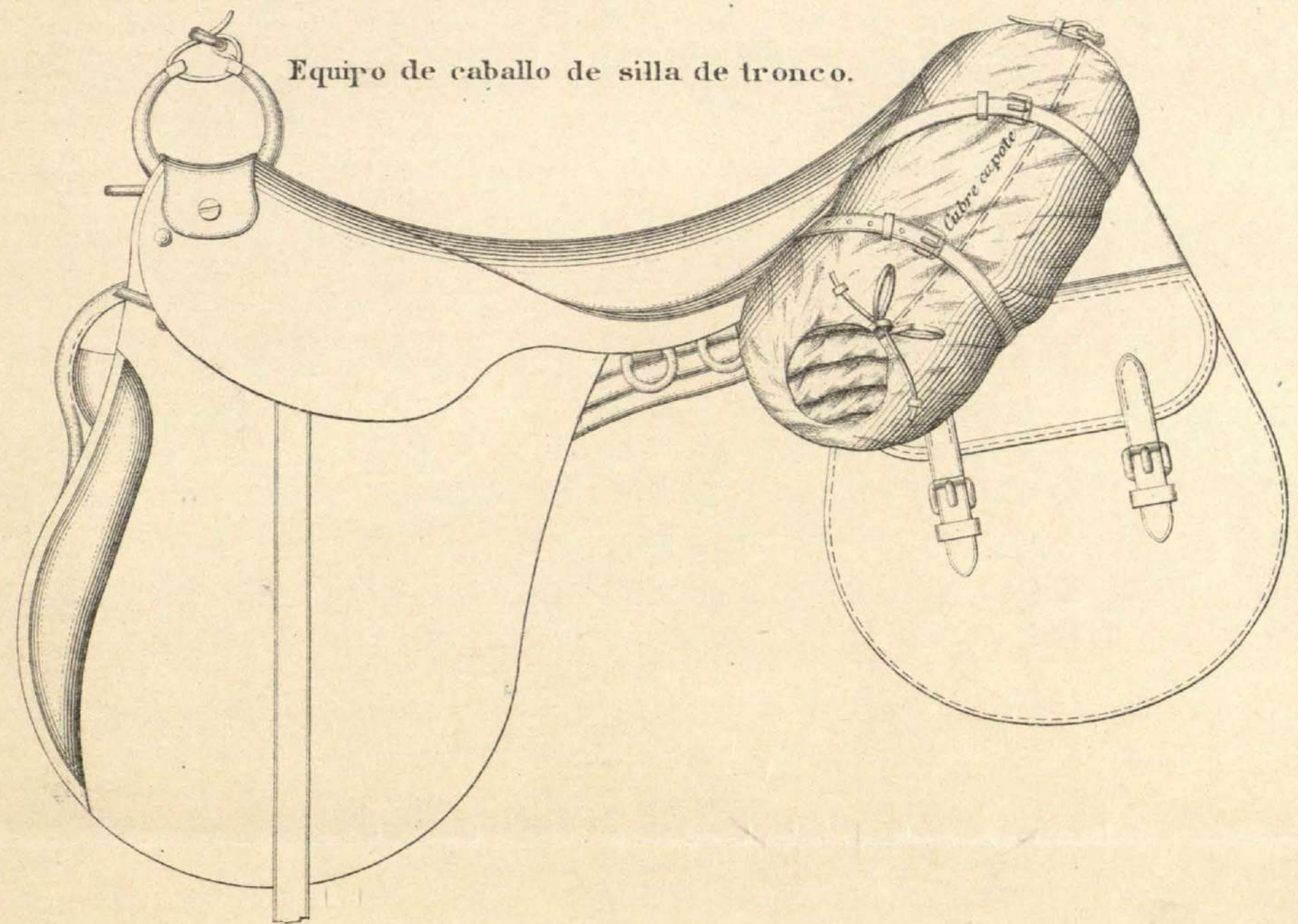

Escala 1/5

Equipo de caballo de mano de tronco

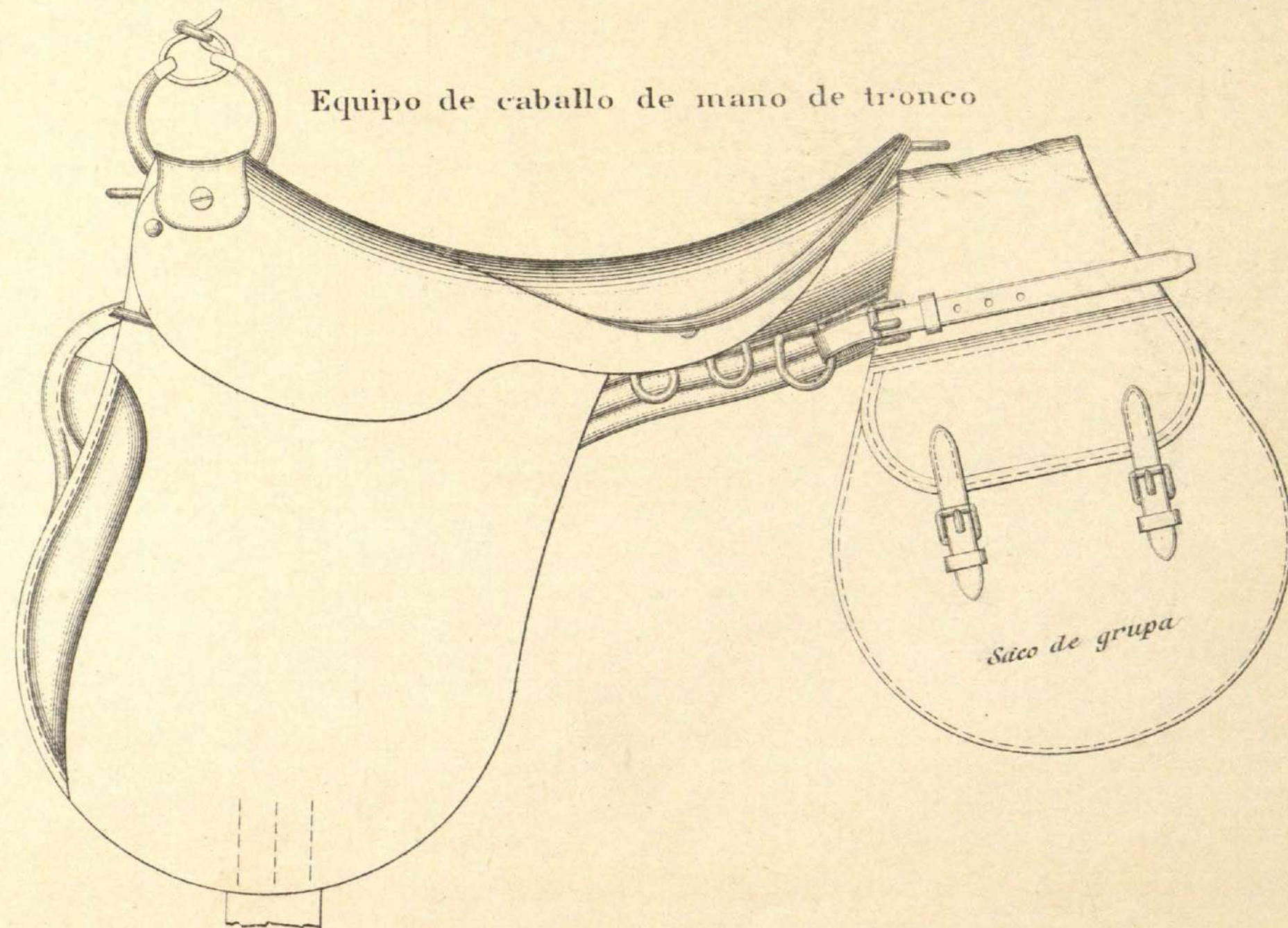

Equipo de gala de caballo de oficial

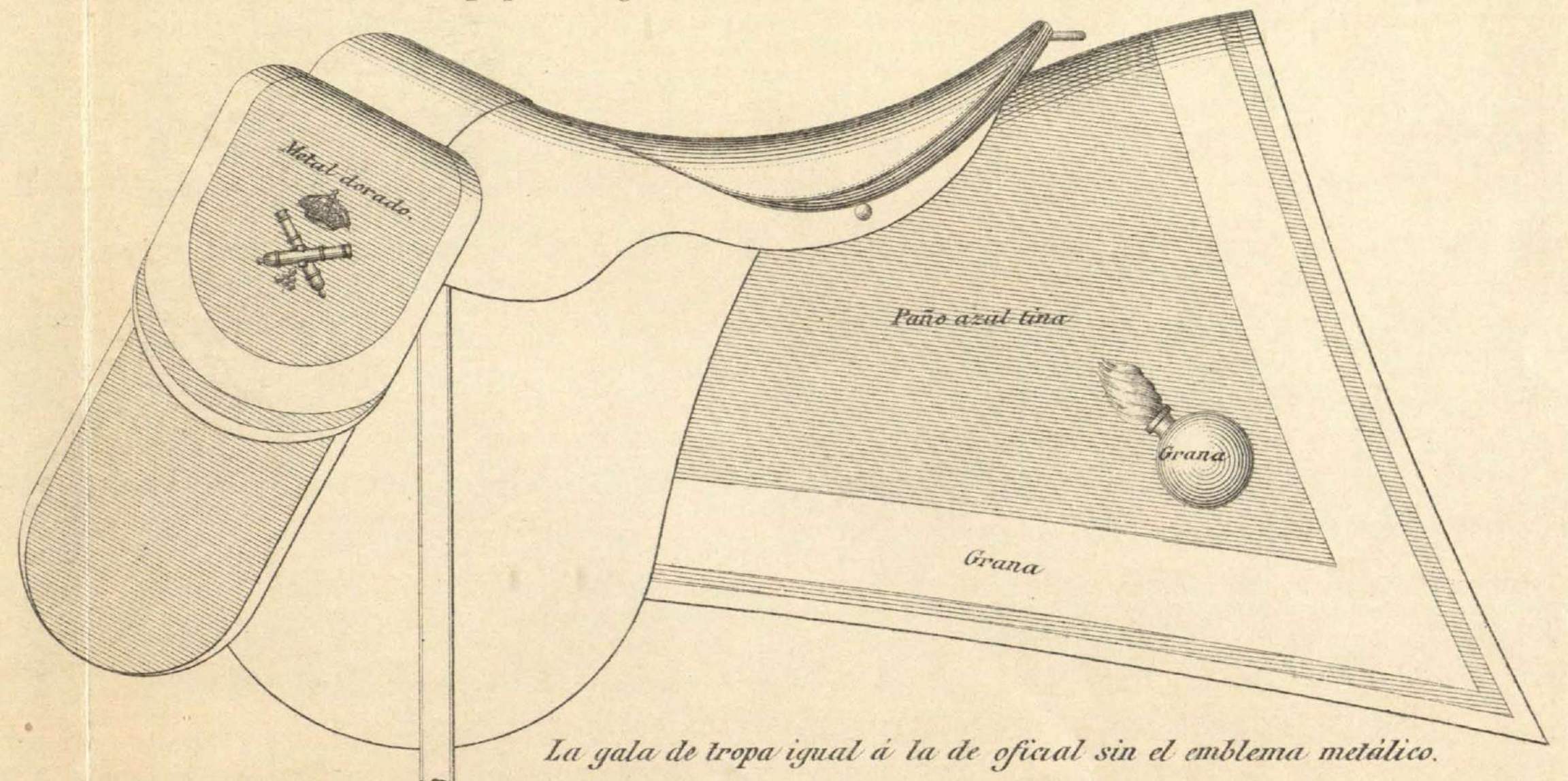

La gala de tropa igual á la de oficial sin el emblema metálico.

# EQUIPO Y MONTURA PARA LOS REGIMIENTOS MONTADOS DEL ARMA DE ARTILLERÍA Md. 1914.

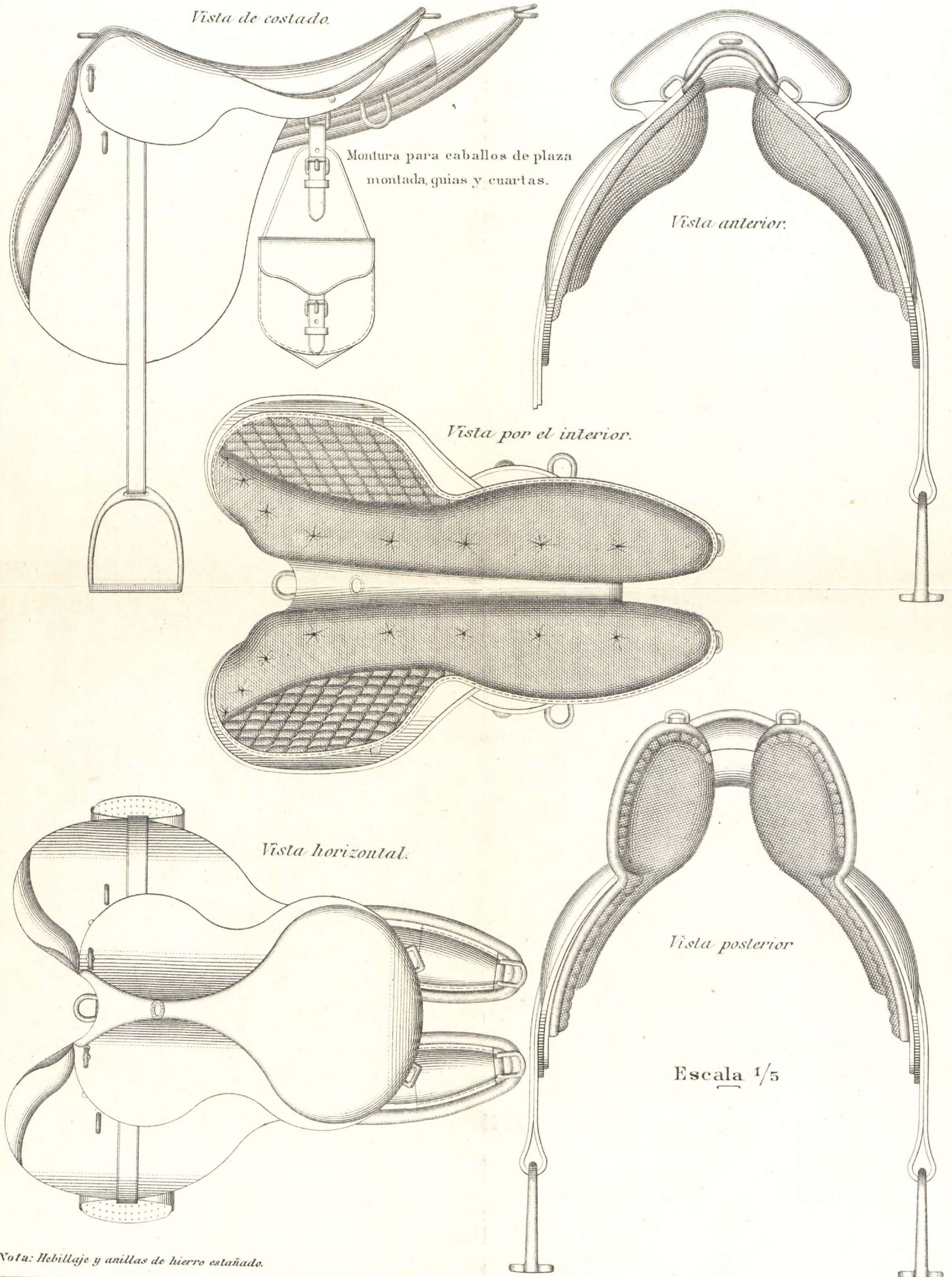

Nota: Hebillaje y anillas de hierro estañado.

# EQUIPO Y MONTURA PARA LOS REGIMIENTOS MONTADOS DEL ARMA DE ARTILLERÍA Md. 1914.

## DETALLES DE LA MONTURA DE PLAZA MONTADA GUIAS Y CUARTAS.

Fuste ó armadura. (E.-1/5.)

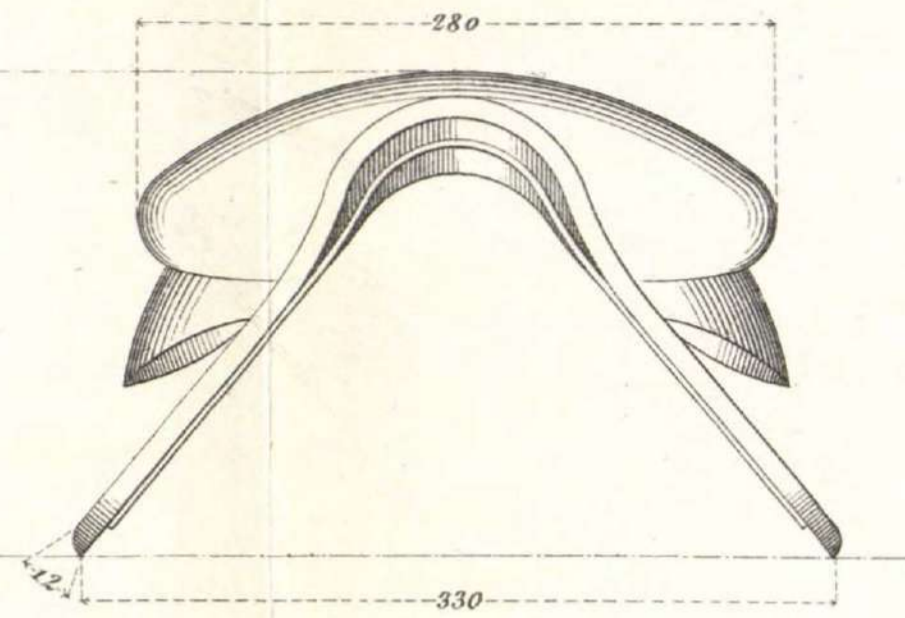
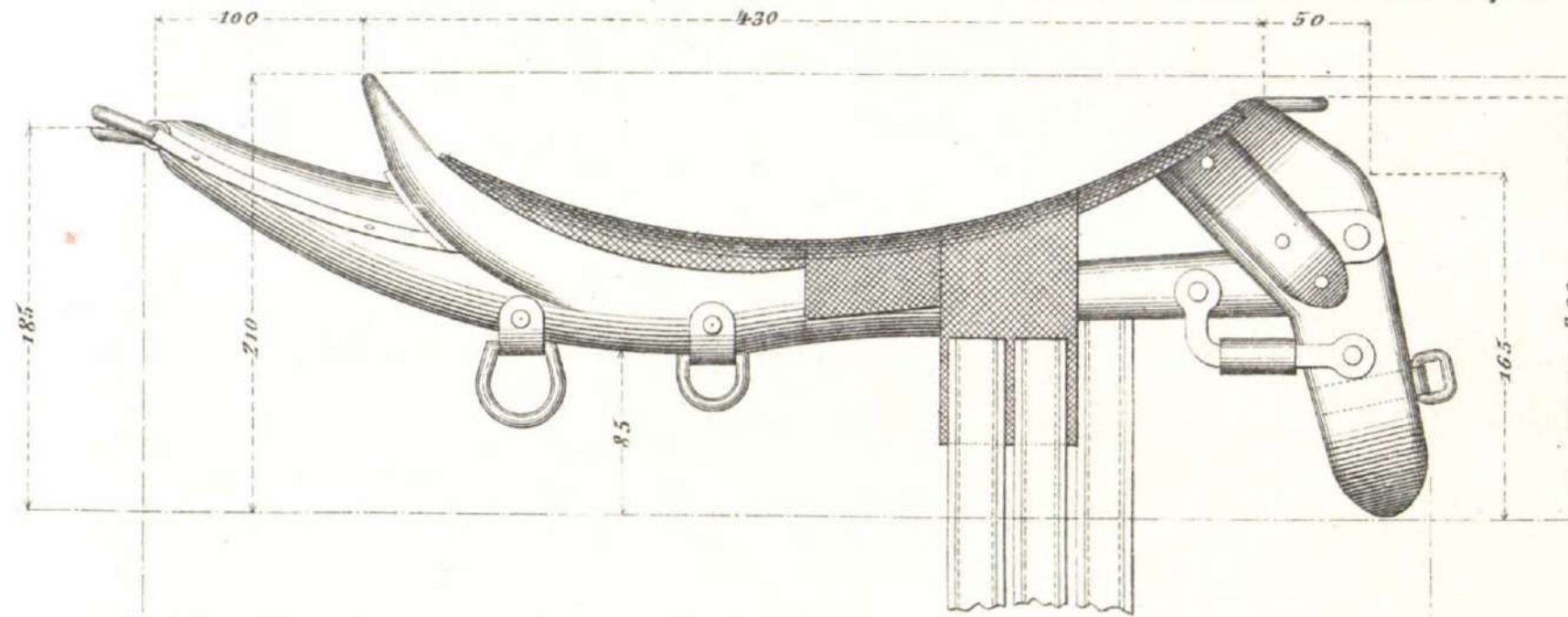

Refuerzo del coçotillo. (E.-1/2.)

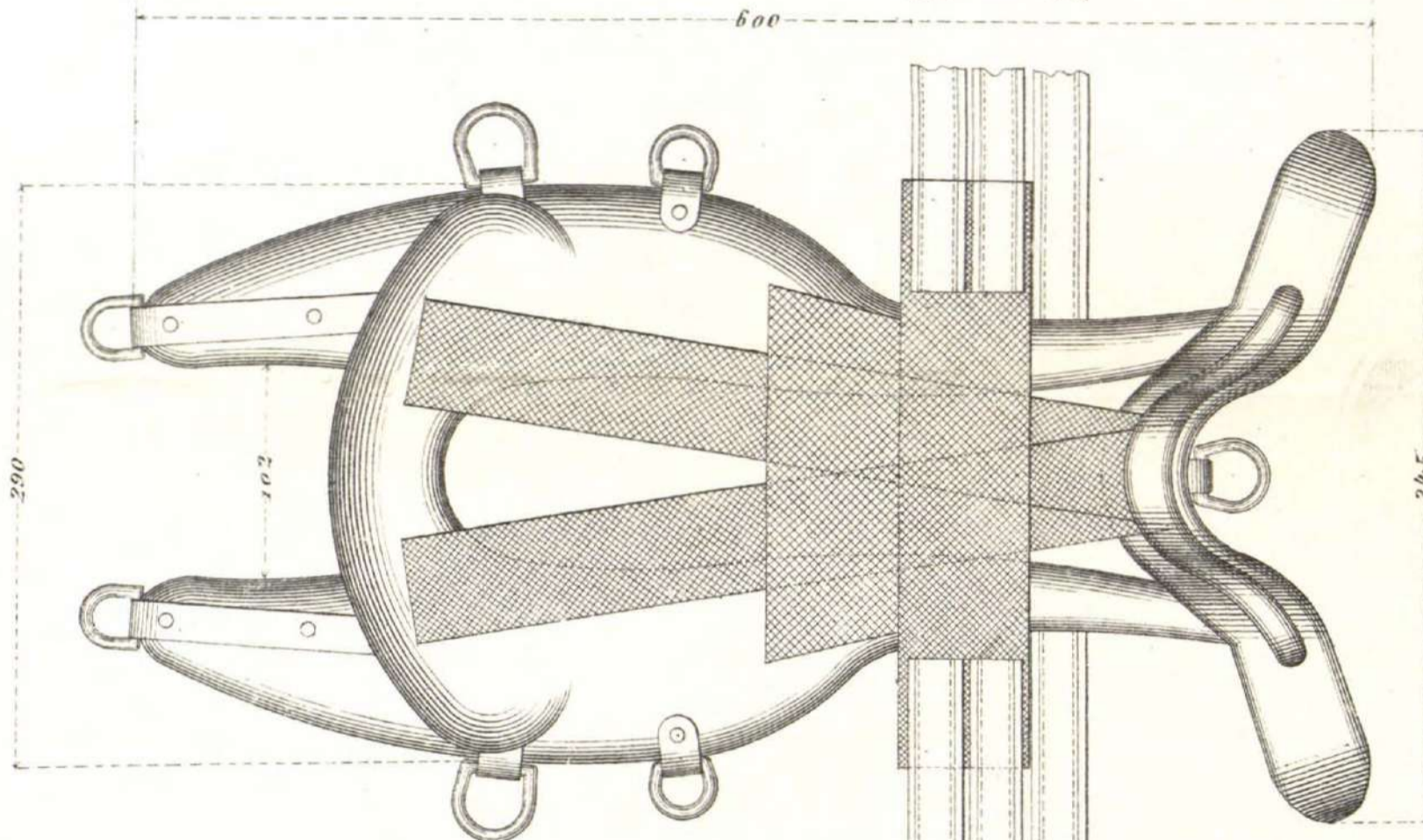
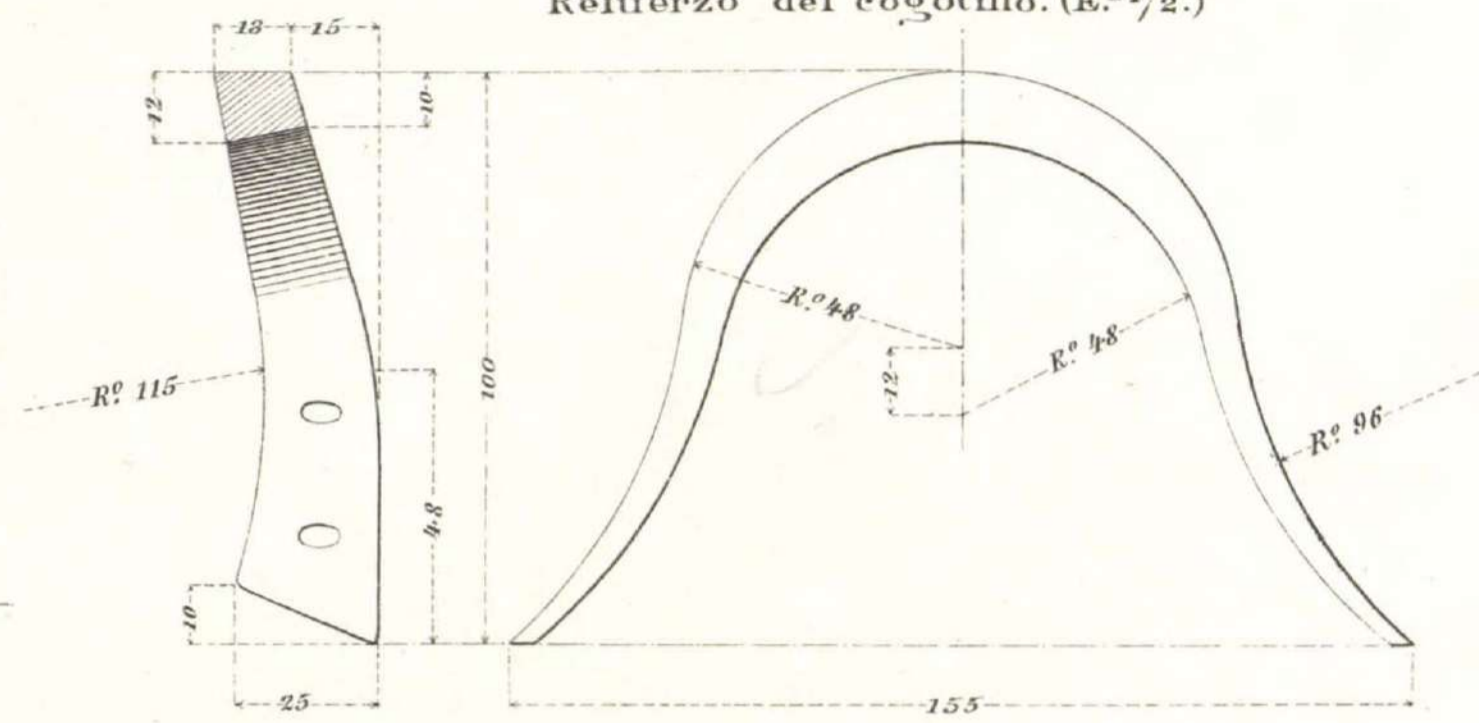

Chapa inferior del coçotillo (E.-3/10.)

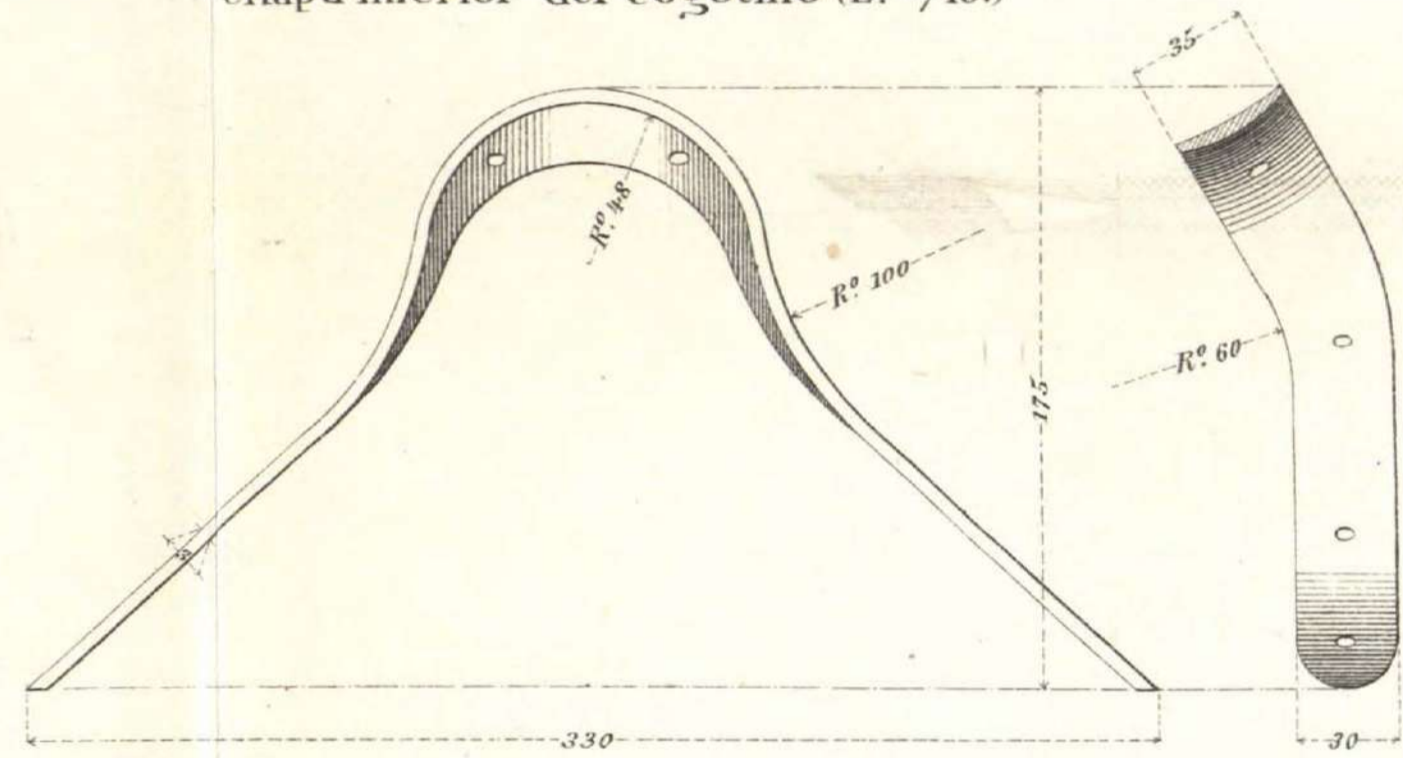

Sección por a.b. (E.-1/1.)

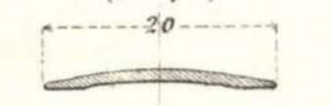

Grapas traseras. (E.-1/2.)

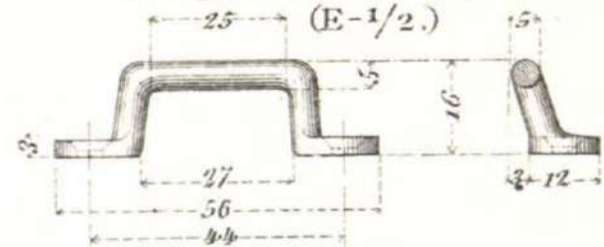

Refuerzo del fuste trasero. (E.-1/5.)

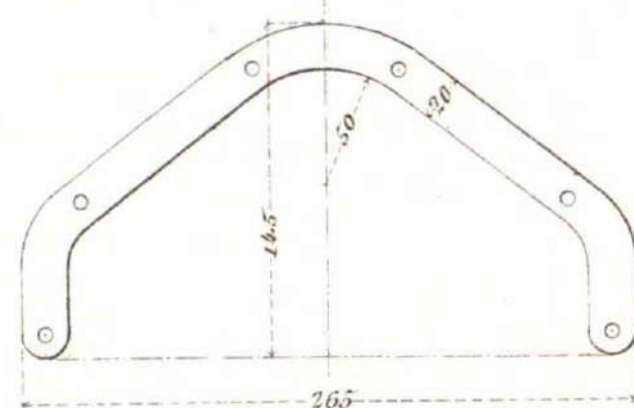

Chapa superior del coçotillo. (E.-1/2.)

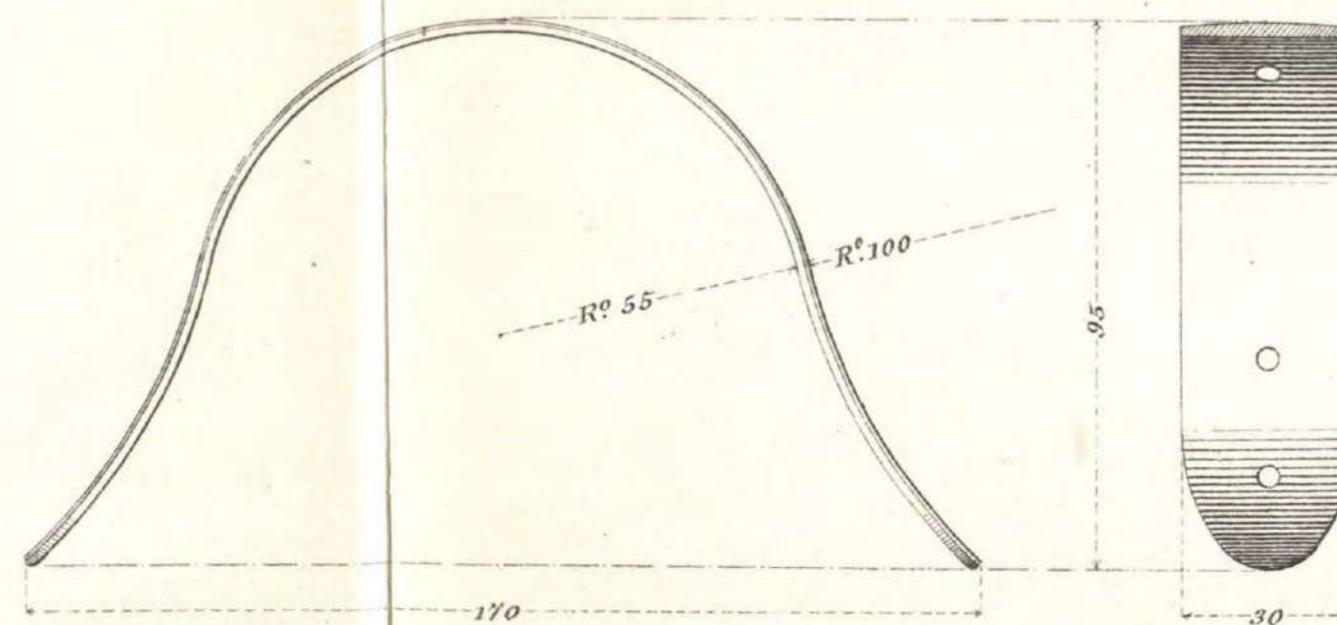

Anillas de las caidas. (E.-3/10.)

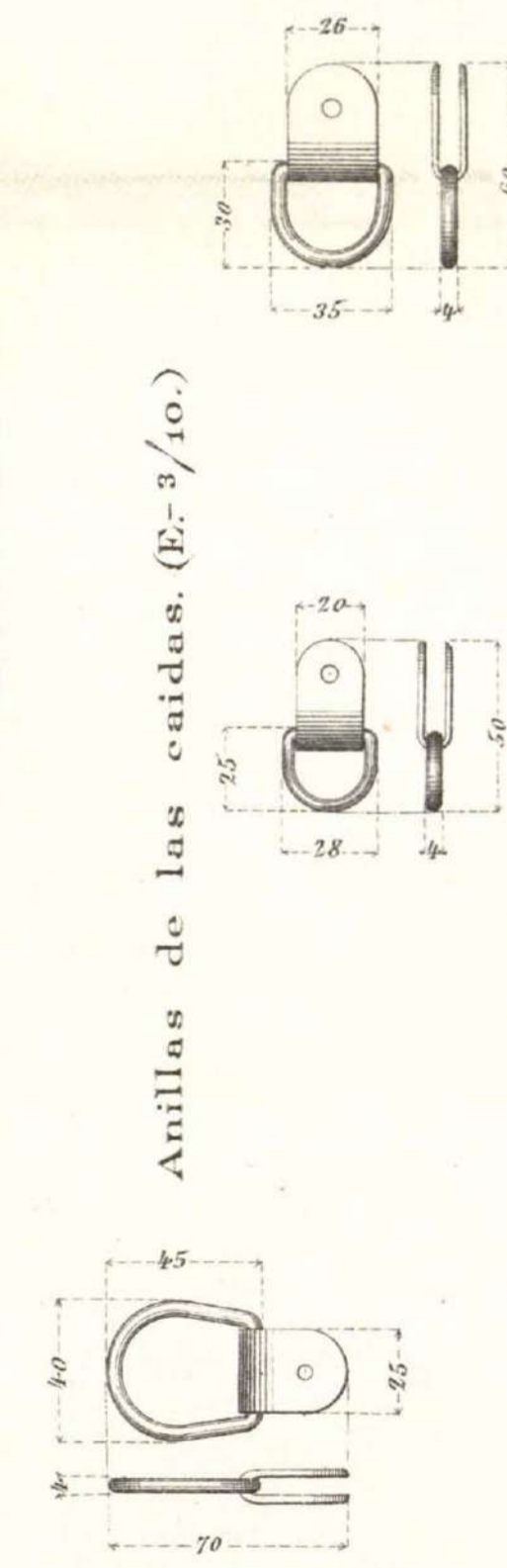

Refuerzos de las bandas. (E.-1/5.)

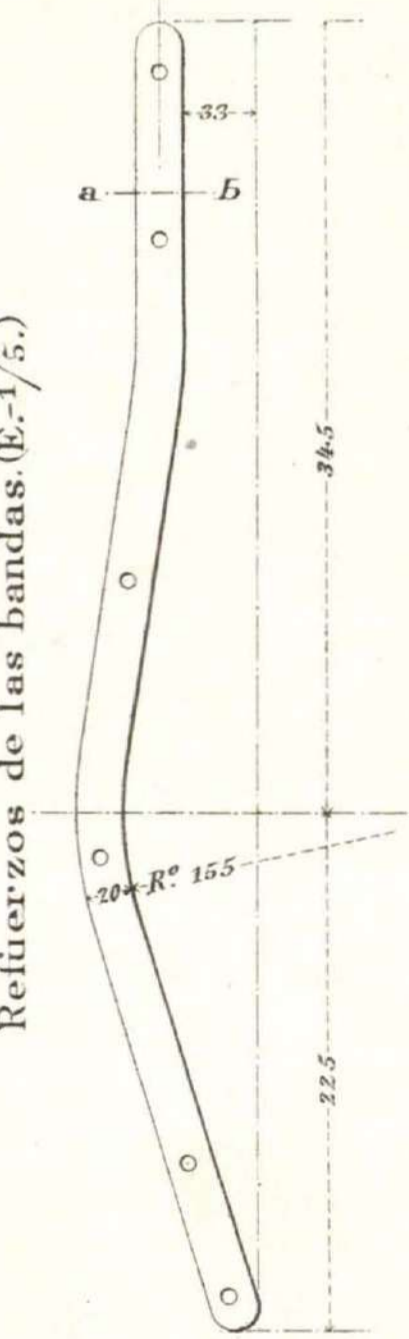

NOTA: Hebilla y Anillas de hierro estañado.



# EQUIPO Y MONTURA PARA LOS REGIMIENTOS MONTADOS DEL ARMA DE ARTILLERIA Md. 1914.

## DETALLES DE LA MONTURA PARA CABALLOS DE TRONCO.

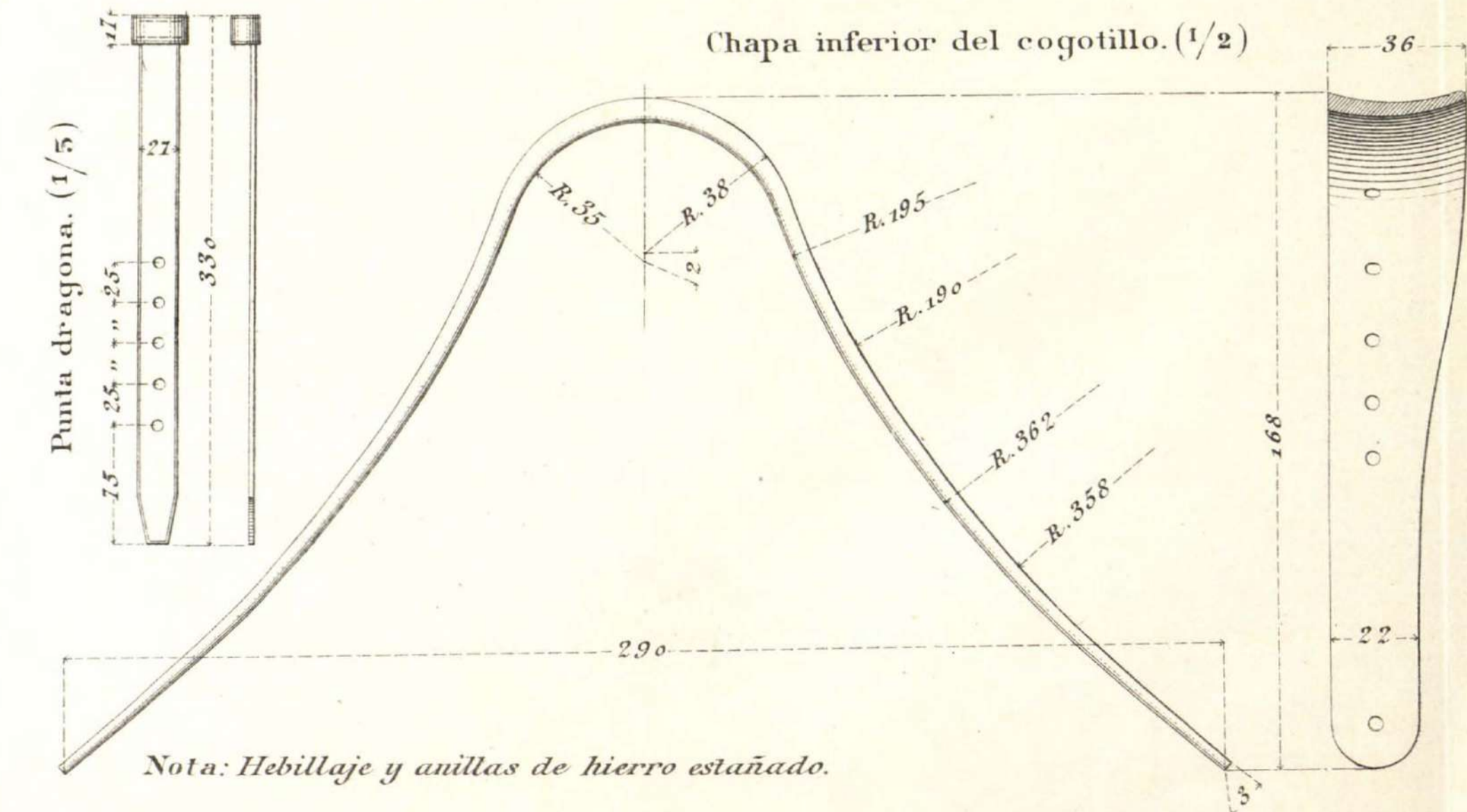
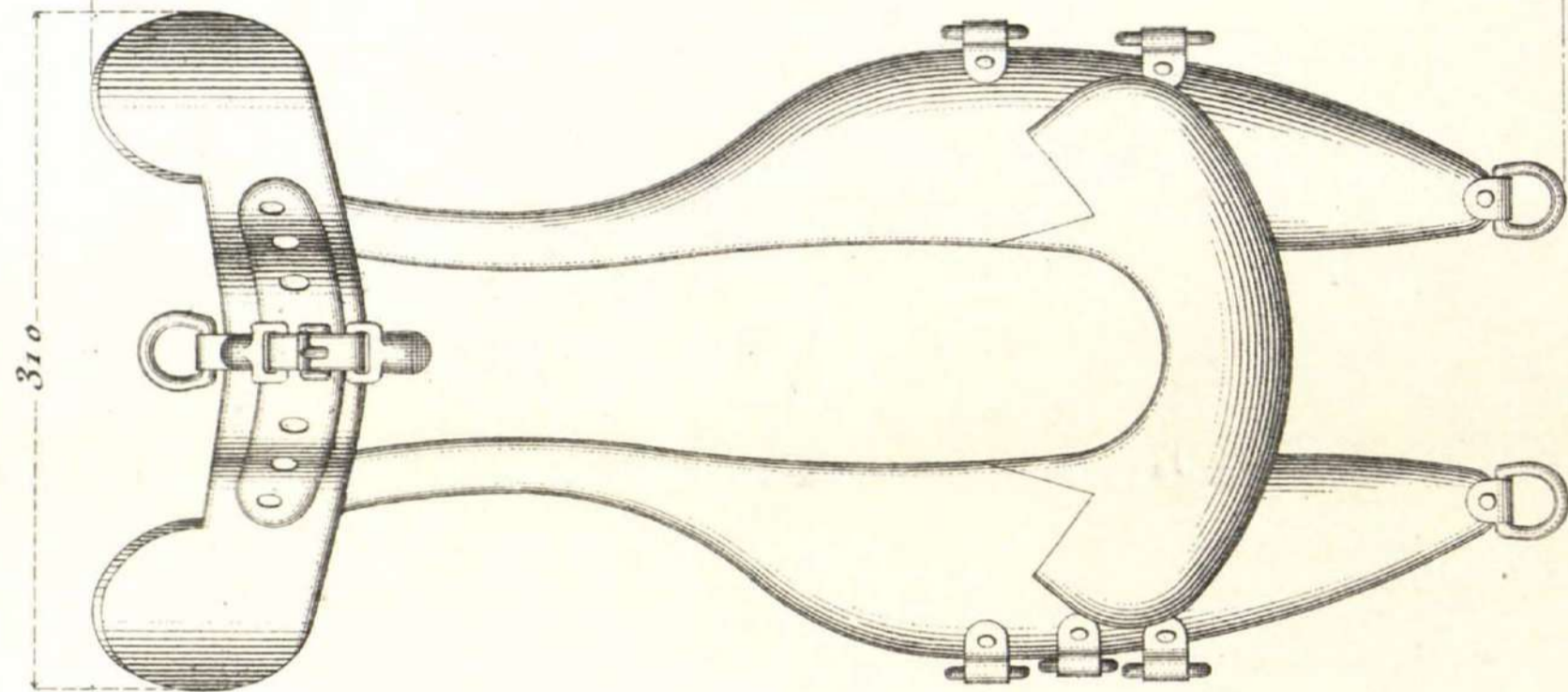
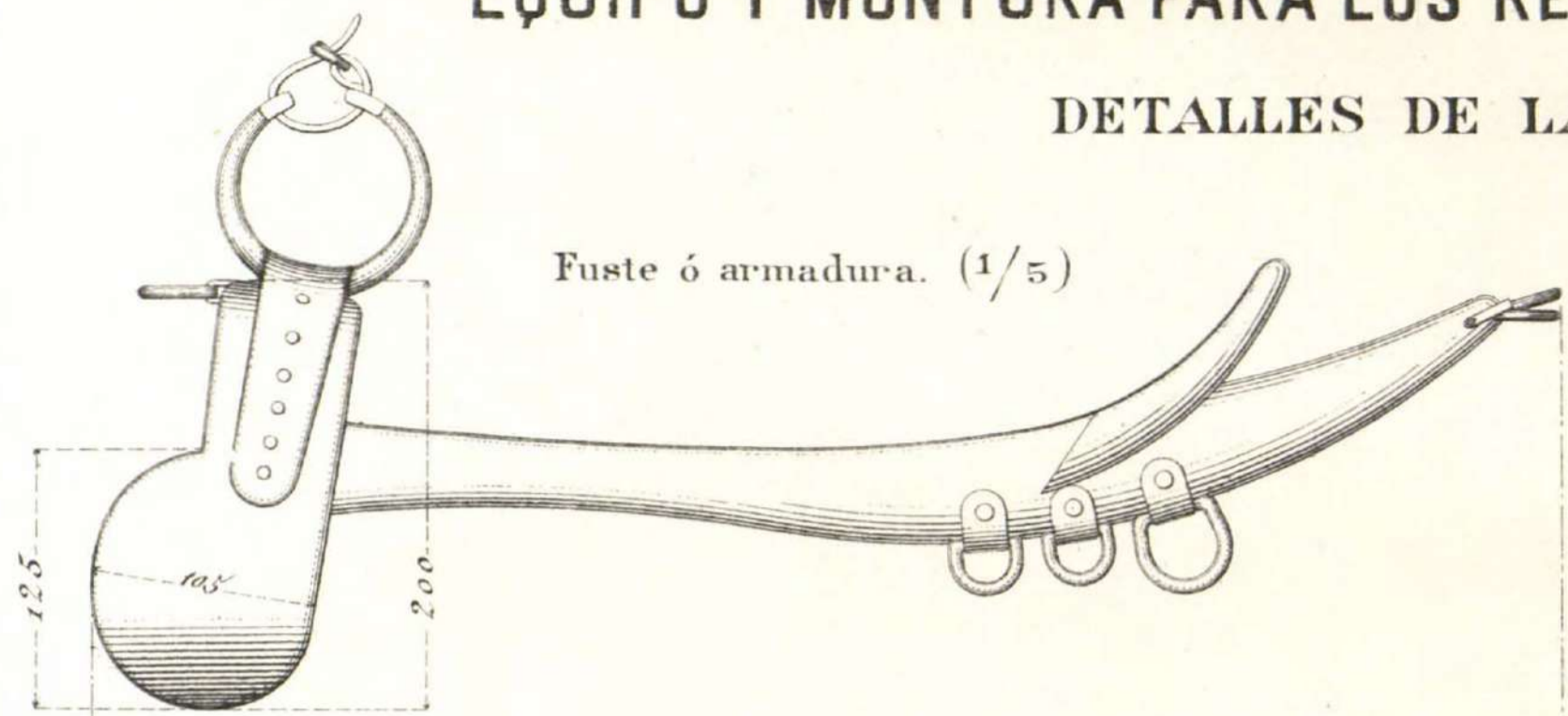

Nota: Hebillaje y anillas de hierro estañado.

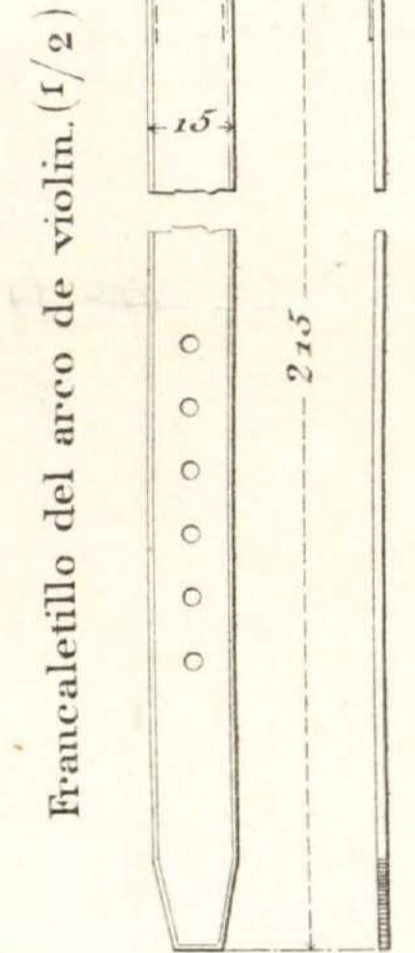
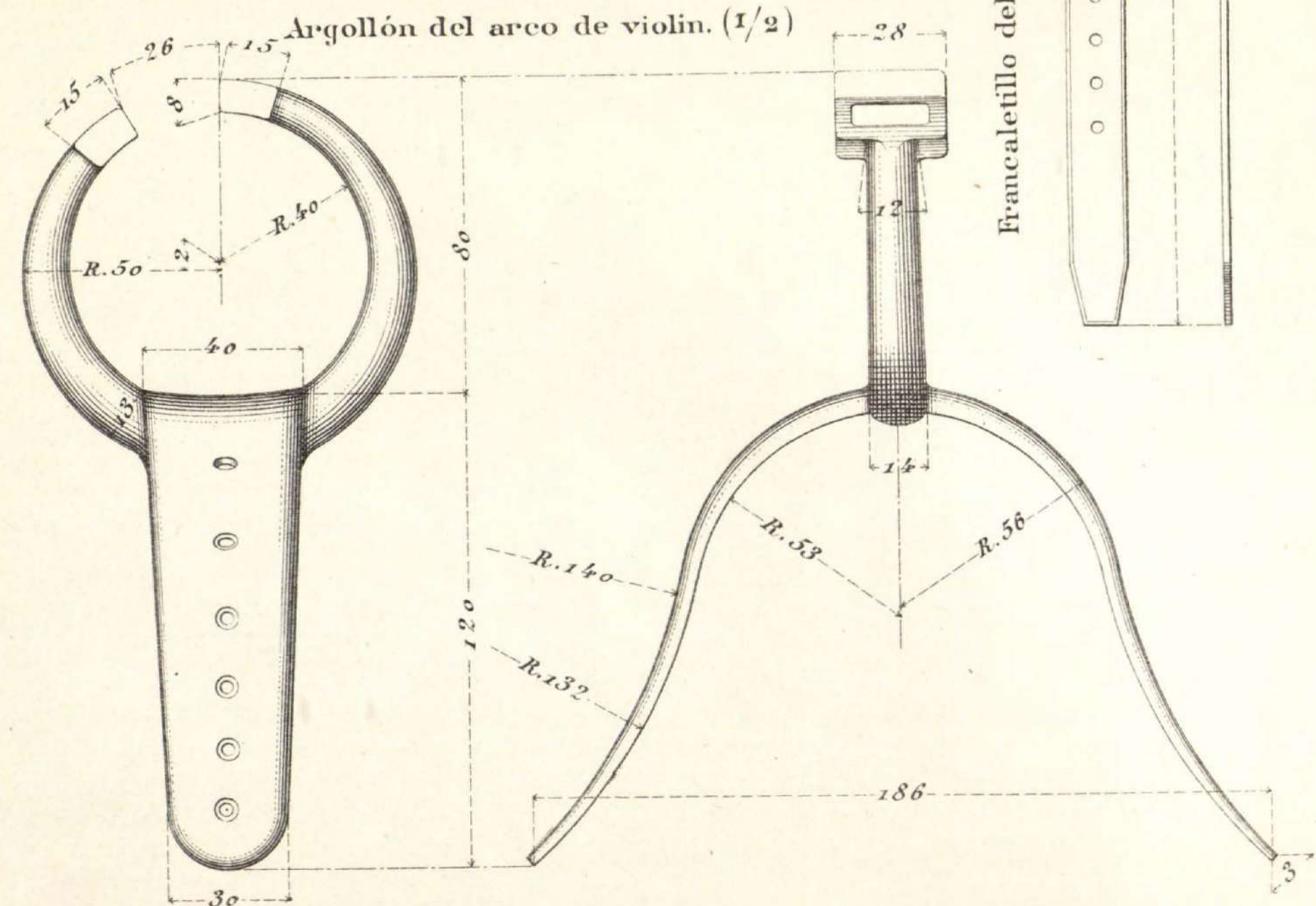
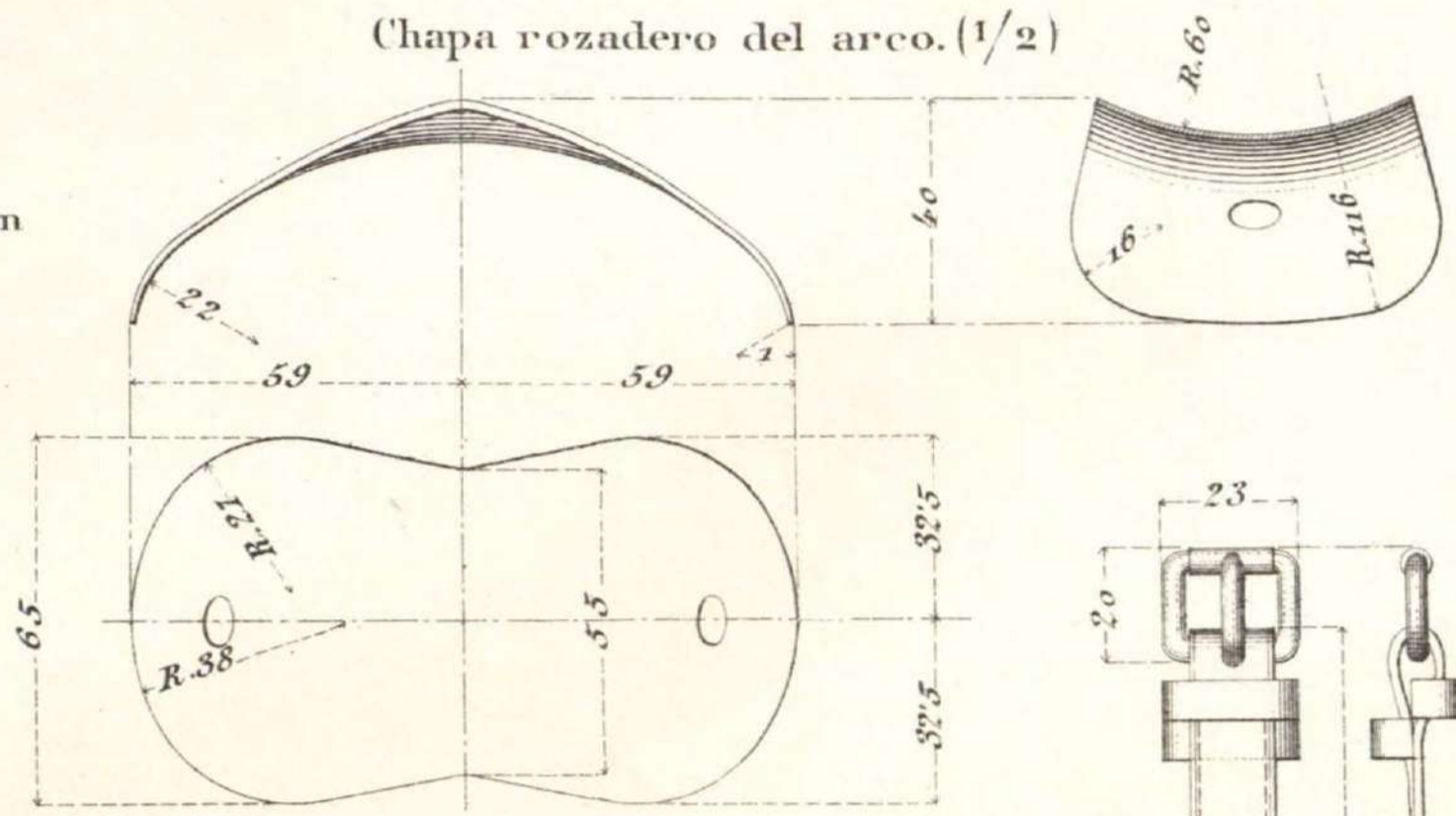
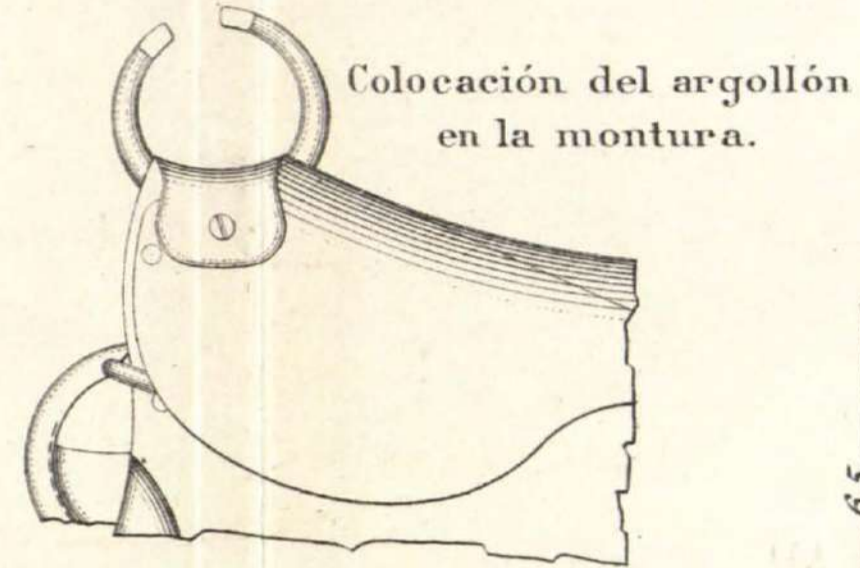



# EQUIPO Y MONTURA PARA LOS REGIMIENTOS MONTADOS DEL ARMA DE ARTILLERÍA Md. 1914.

Escala 1/5.

Cabezada de brida y de pesebre.

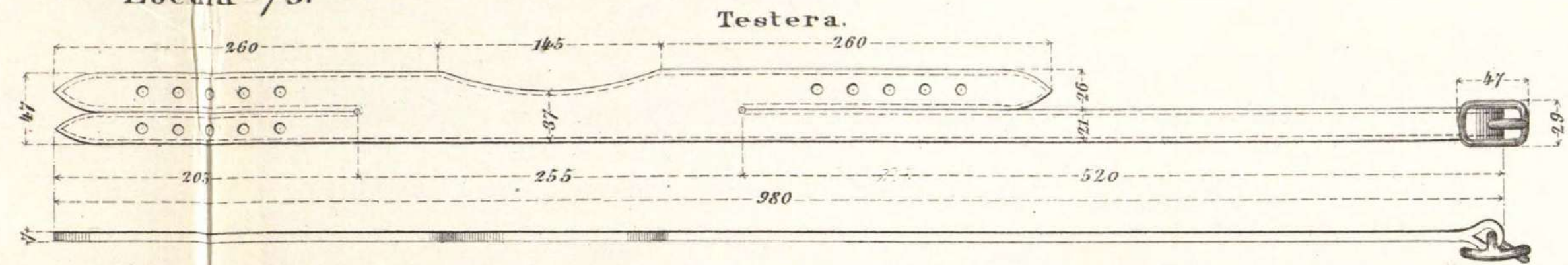
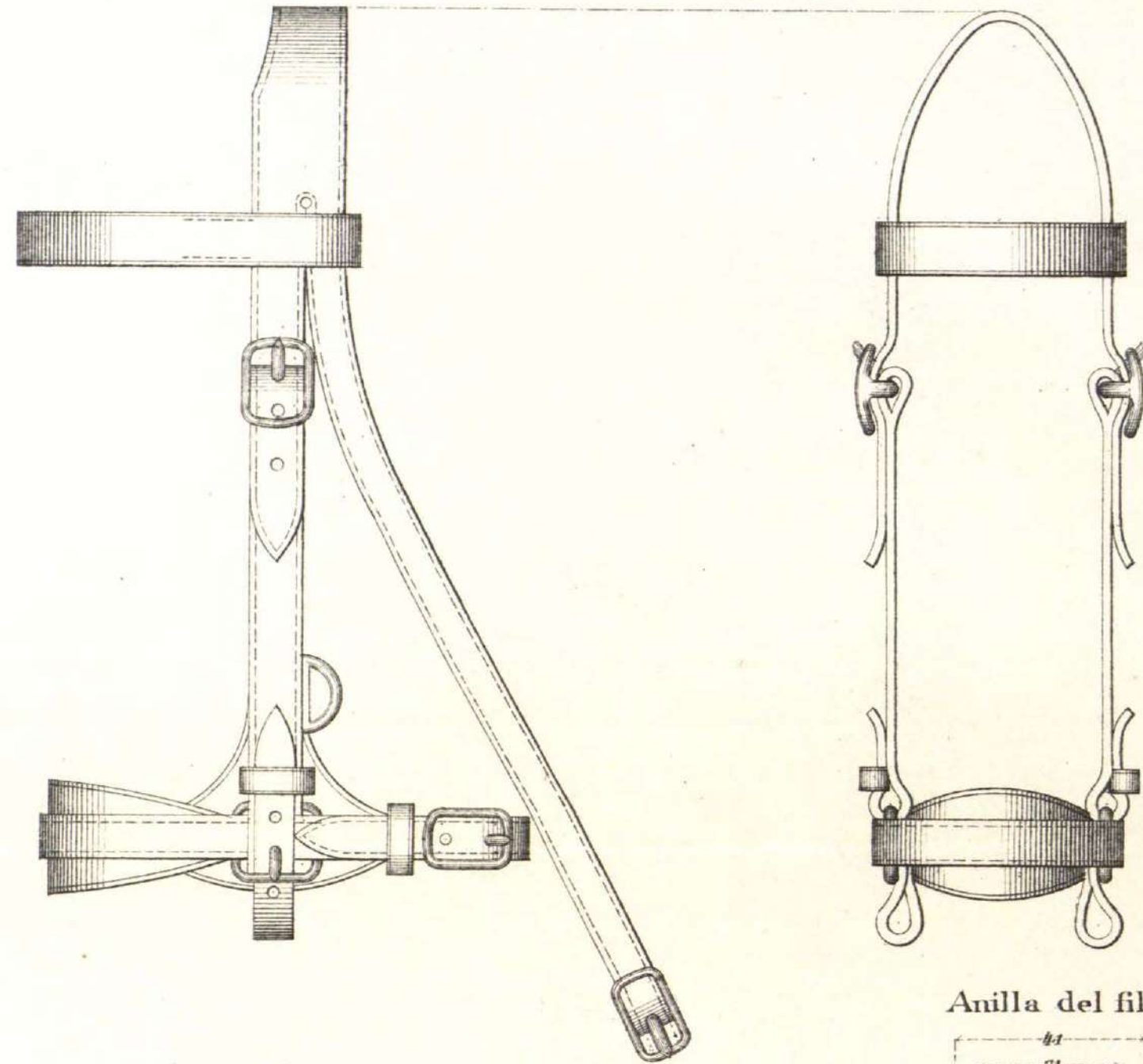

Quijera y bozo.

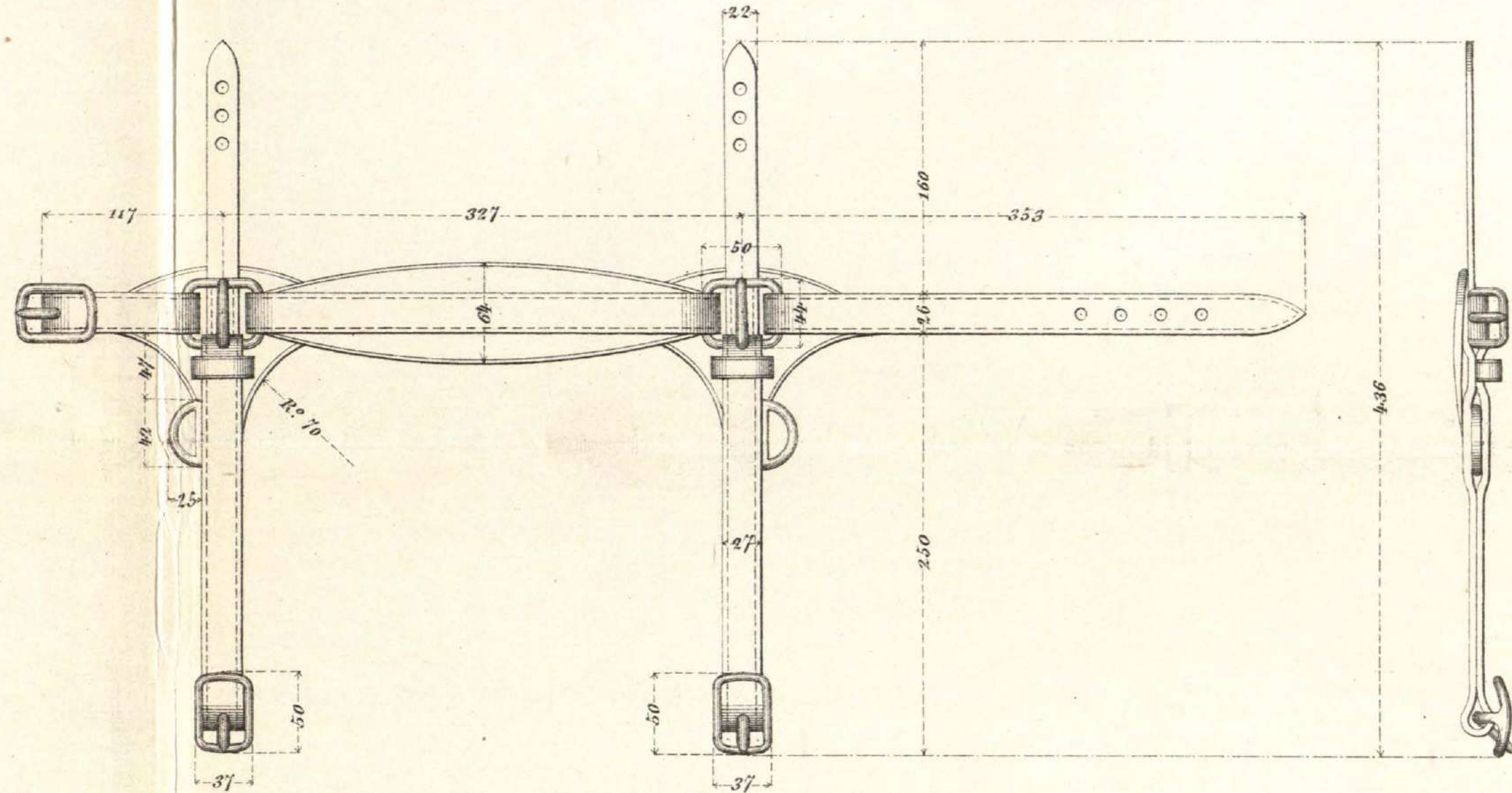

Desarrollo del trocillo de ahogadero.

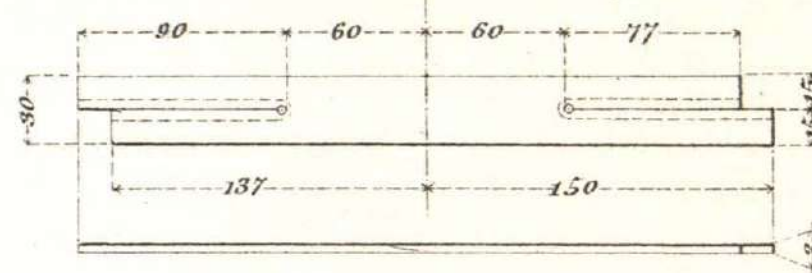

Anilla del filete. (1/2)

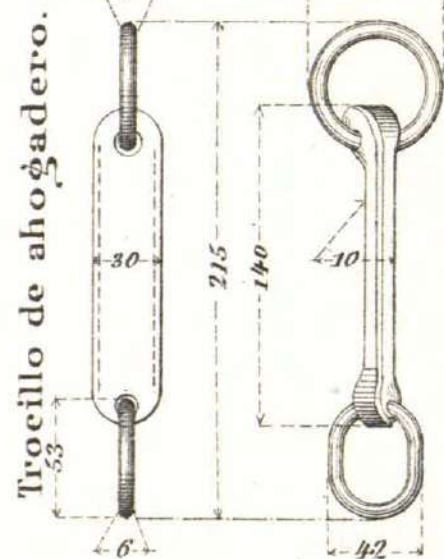
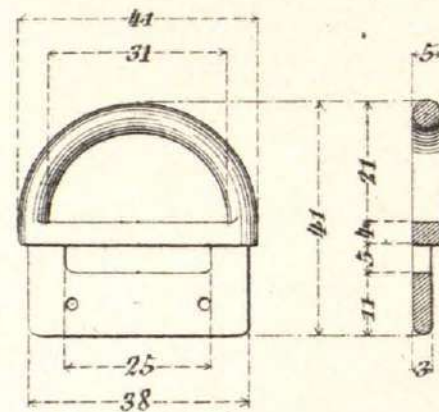

Rienda.

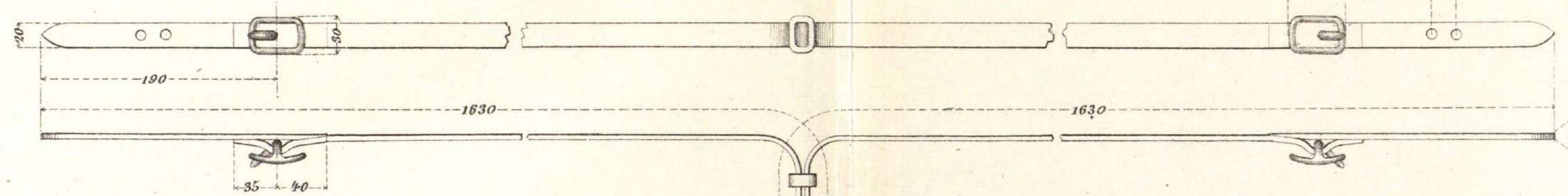

Falsa rienda.

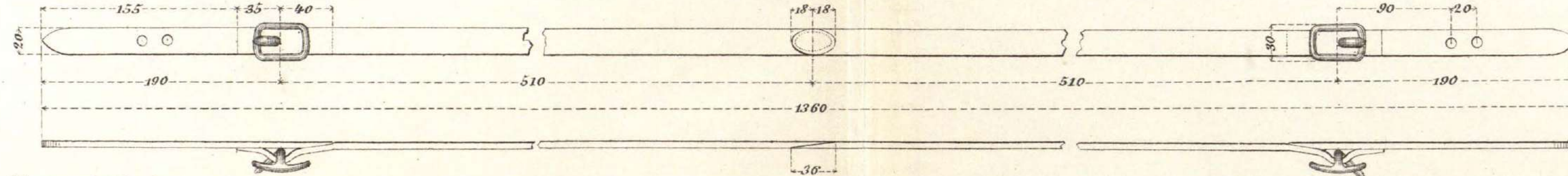

Frontalera.

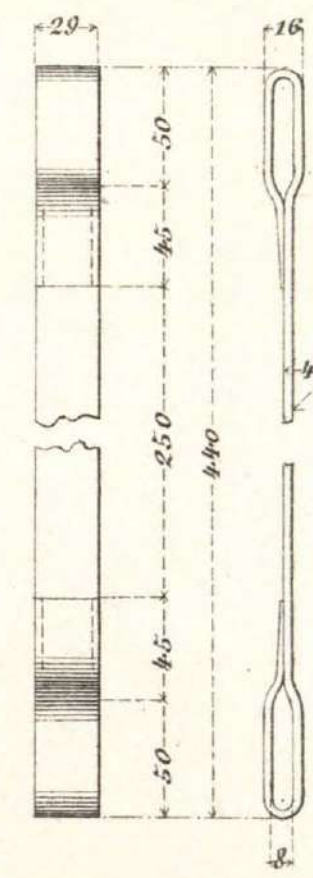

NOTA: Hebillaje y anillas de hierro estañado.



# EQUIPO Y MONTURA PARA LOS REGIMIENTOS MONTADOS DEL ARMA DE ARTILLERIA Md. 1914.

Pecho pretal.

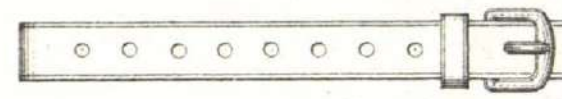

Escala 1/5

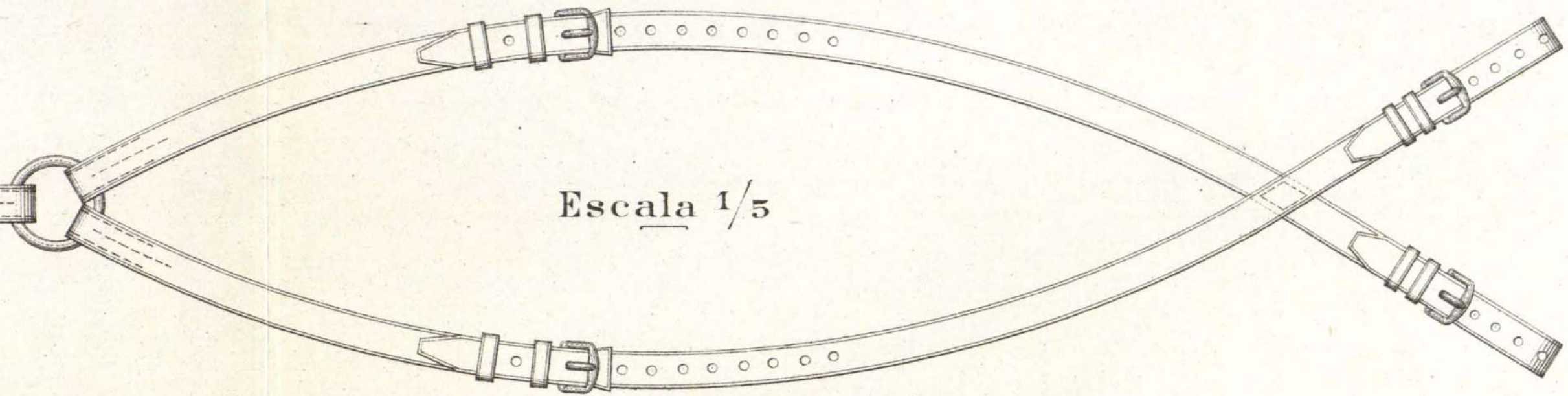

Gamarra

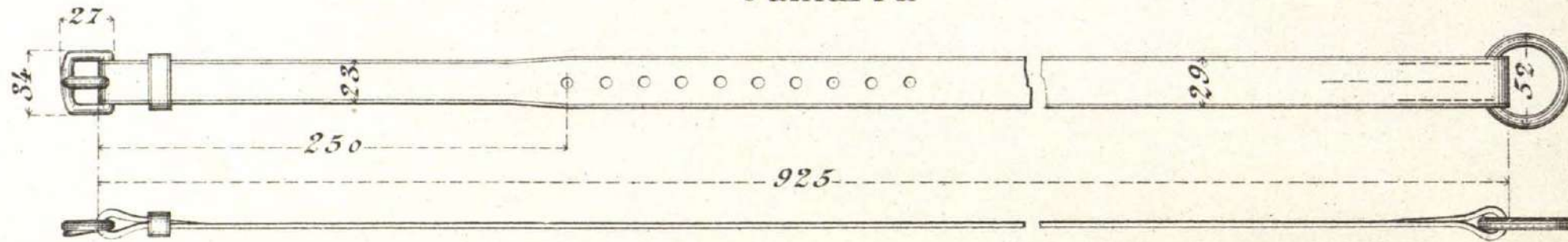

Tijerilla del pretal.

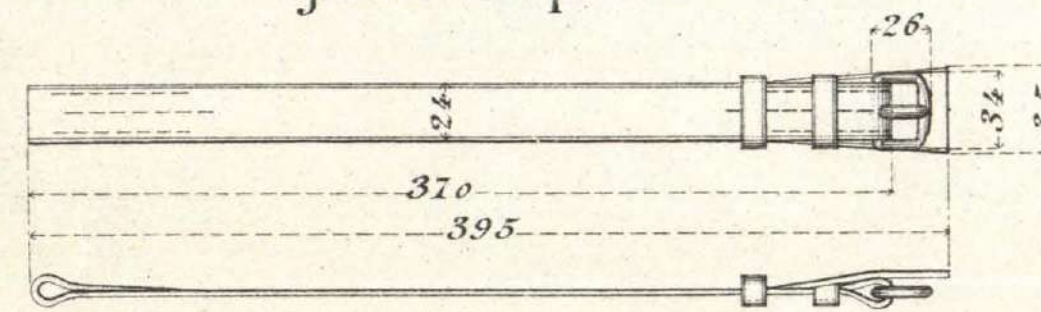

Tahali y bolsa de herraje.

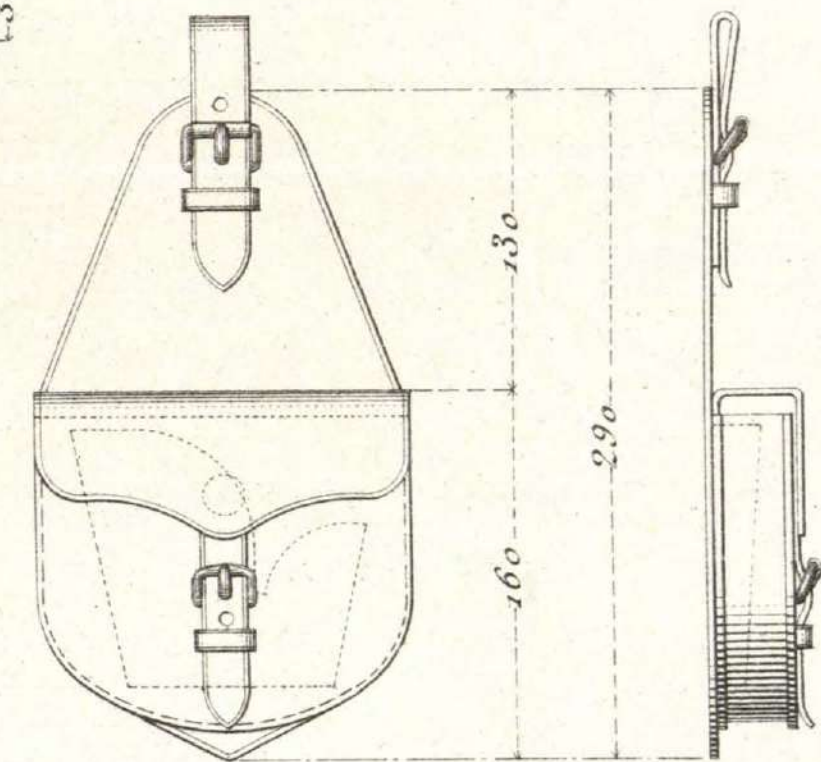

Piernas del pretal.

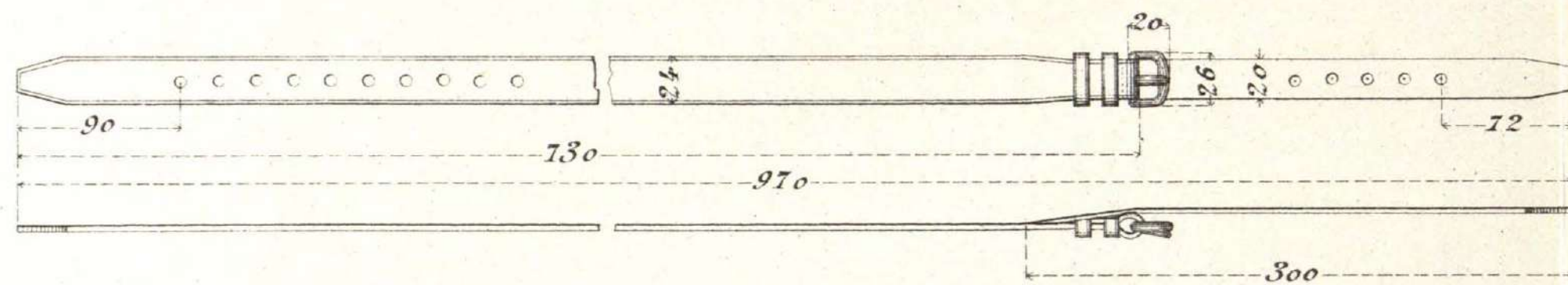

Fuelle de la bolsa.

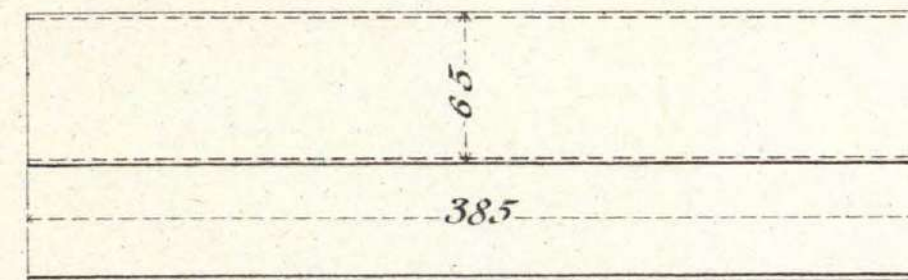

Respaldo de la bolsa.

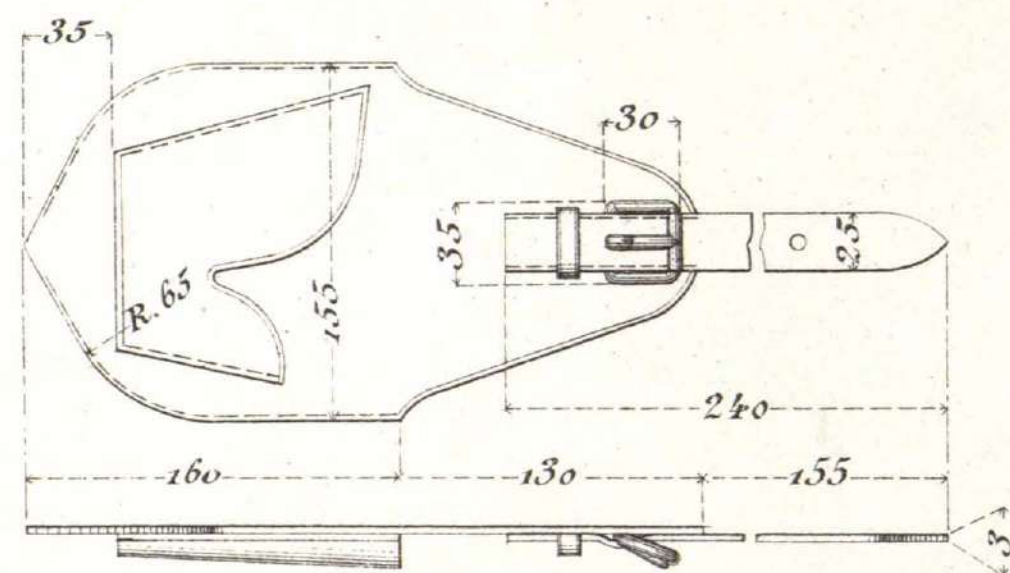

Cara del tahali.

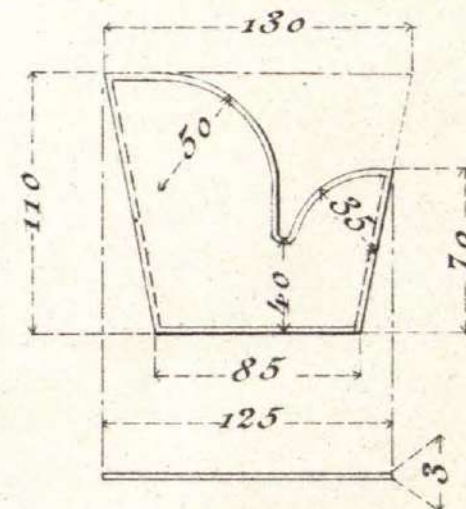

Cara de la bolsa.

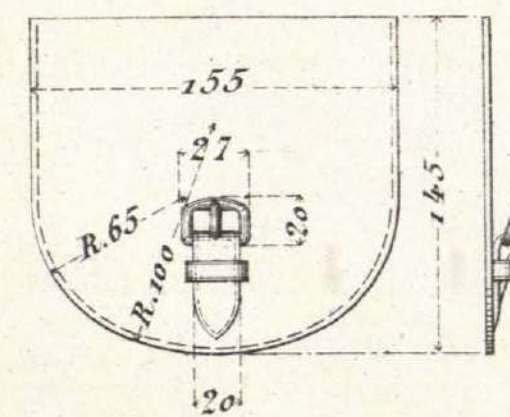

Tapa de la bolsa.

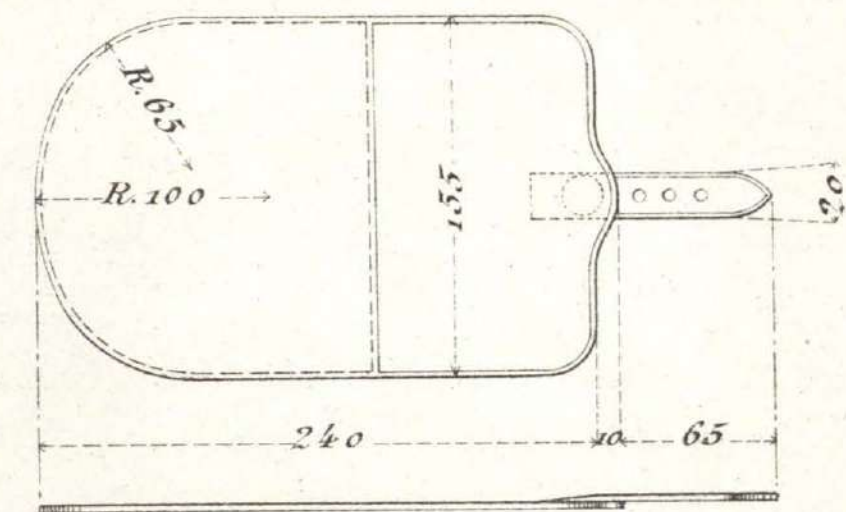

Nota: Hebillaje y anillas de hierro estañado.



# EQUIPO Y MONTURA PARA LOS REGIMIENTOS MONTADOS DEL ARMA DE ARTILLERIA Md. 1914.

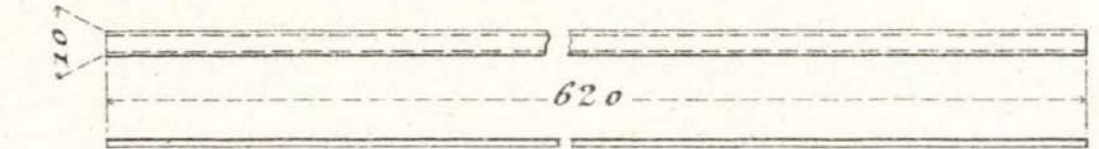
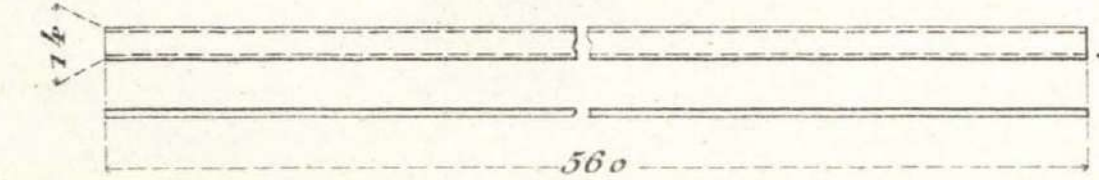
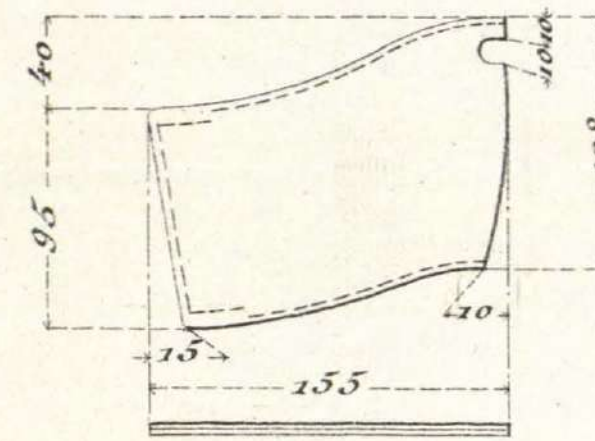
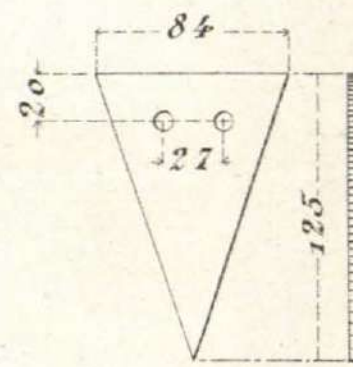
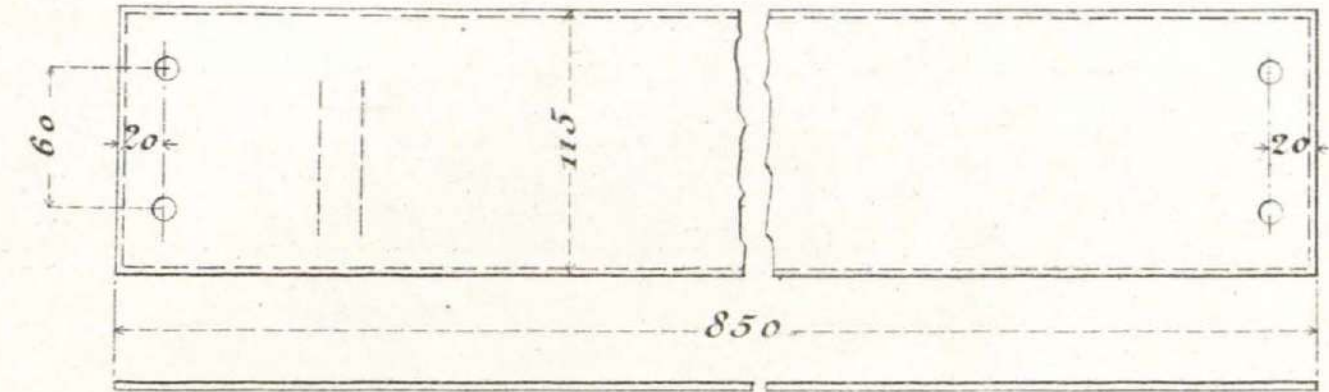
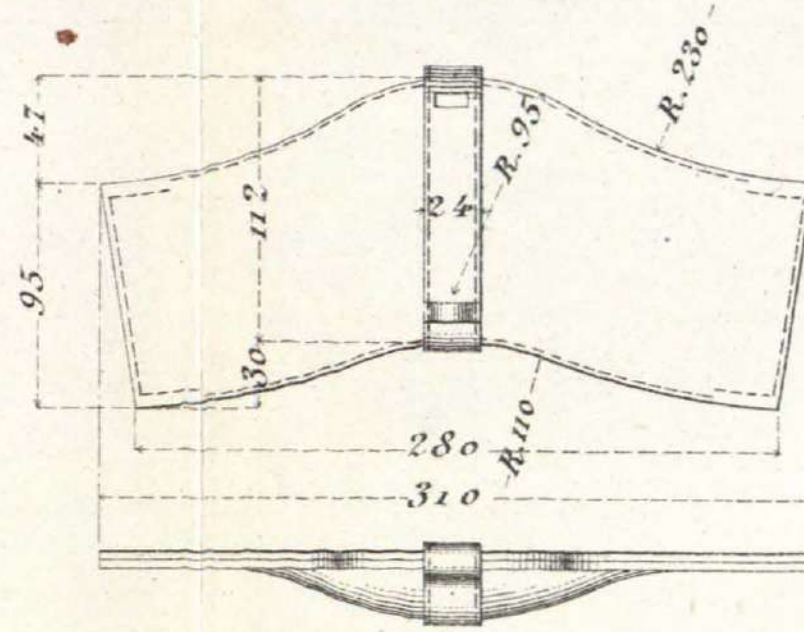
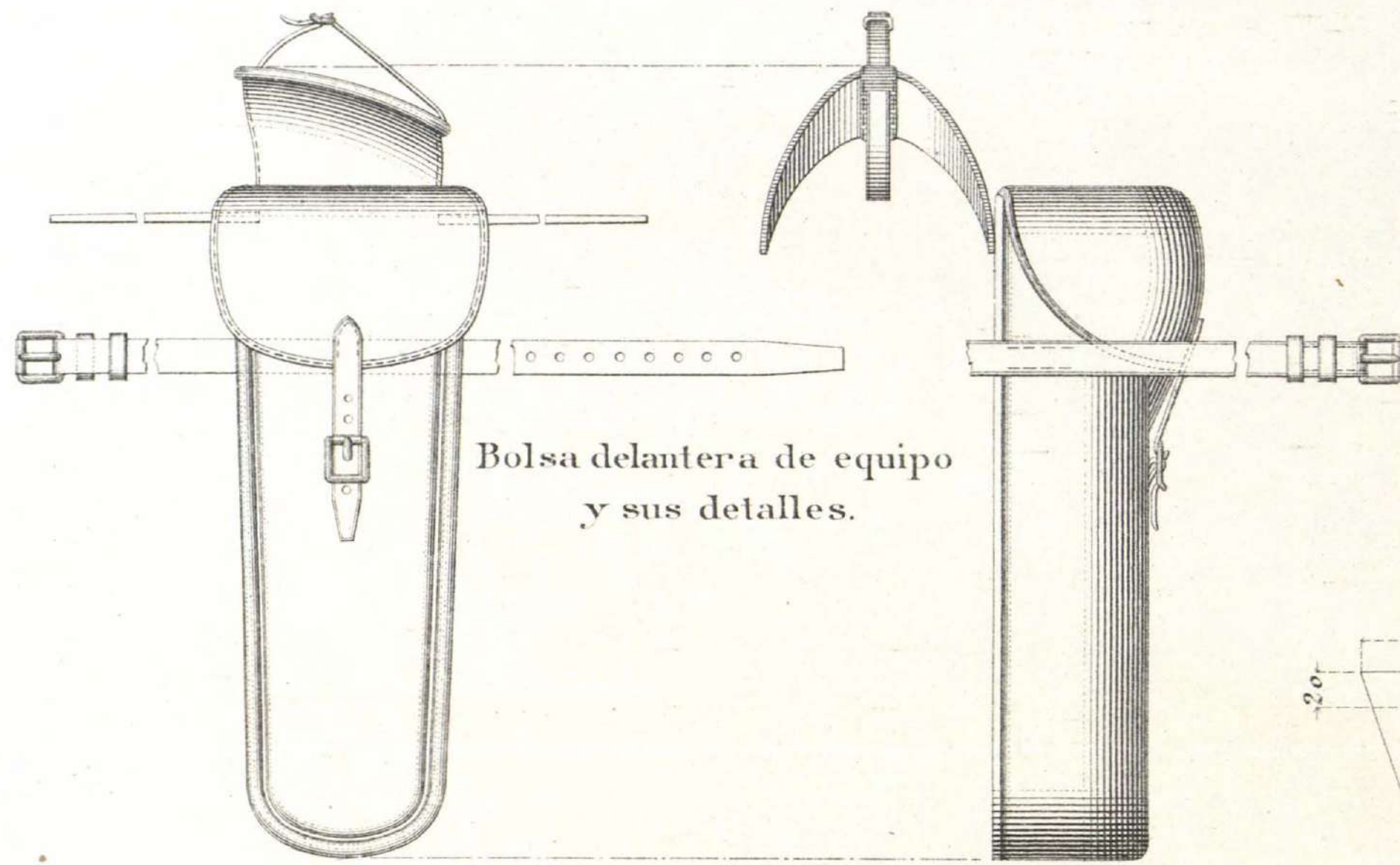

Escala 1/5

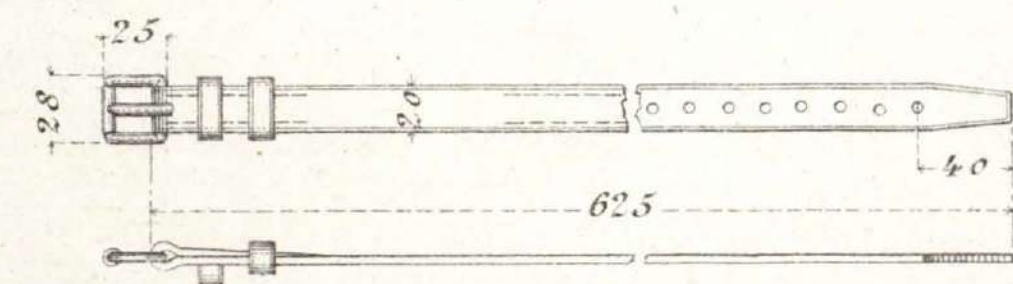
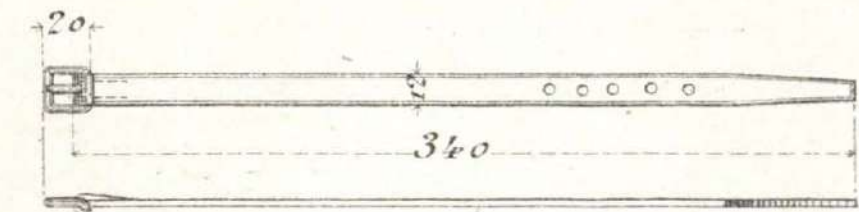
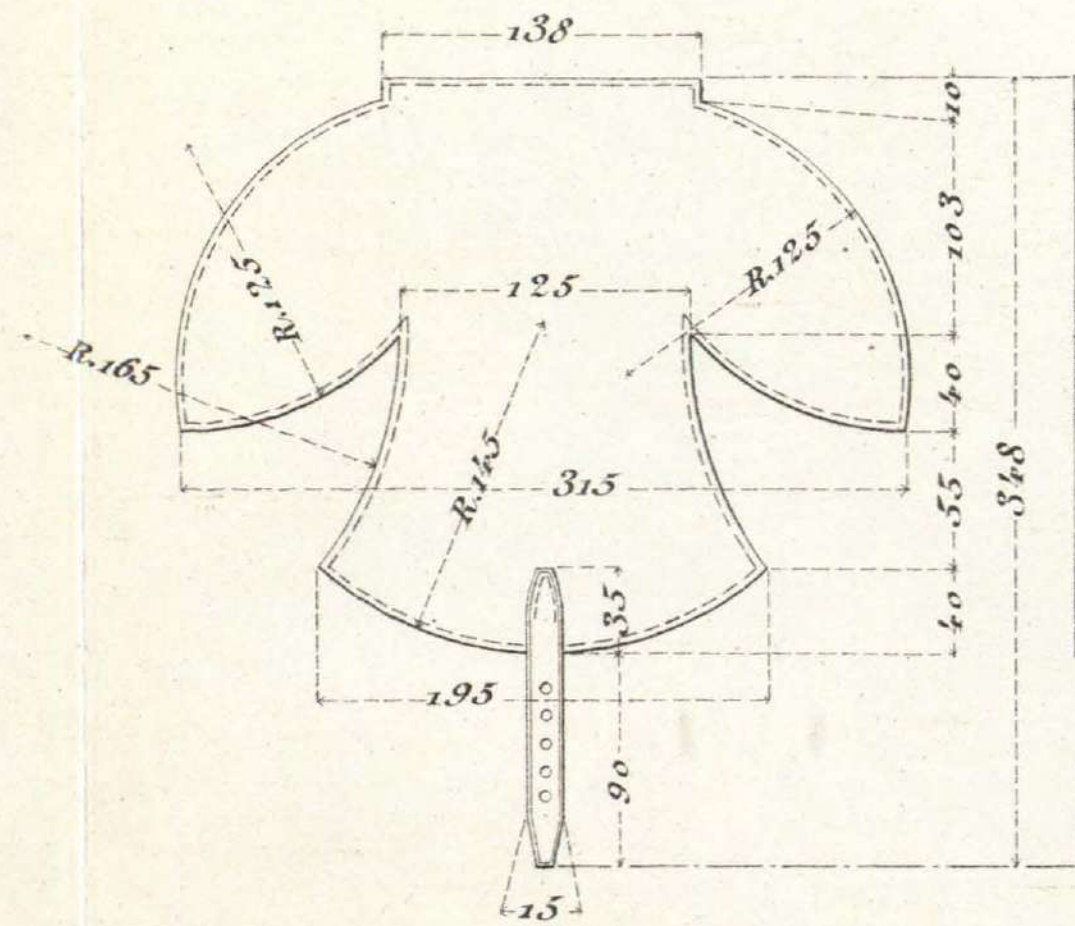
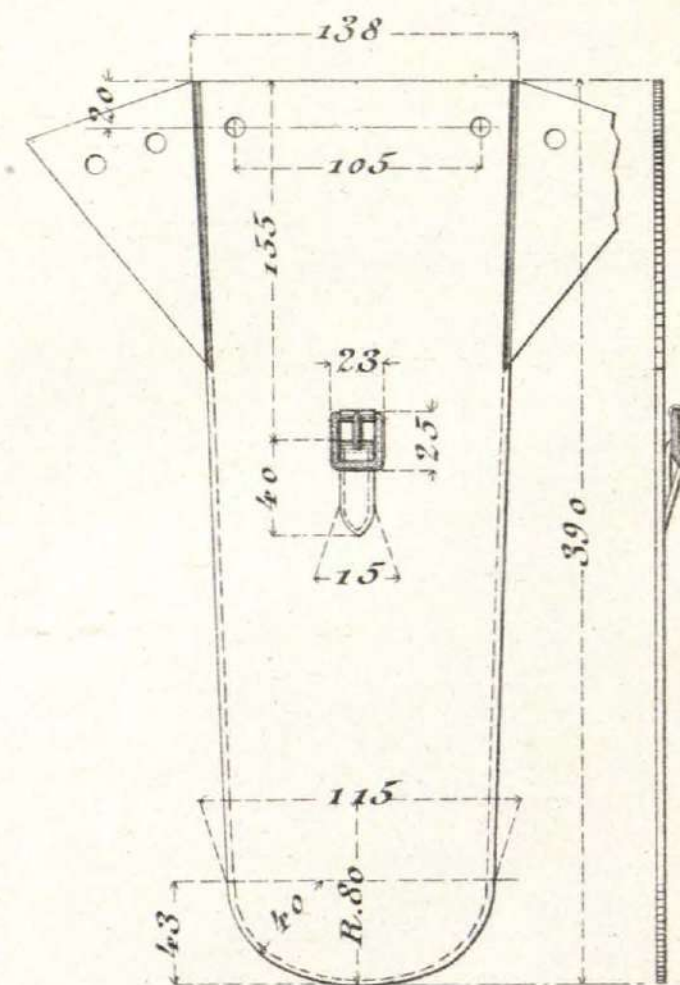
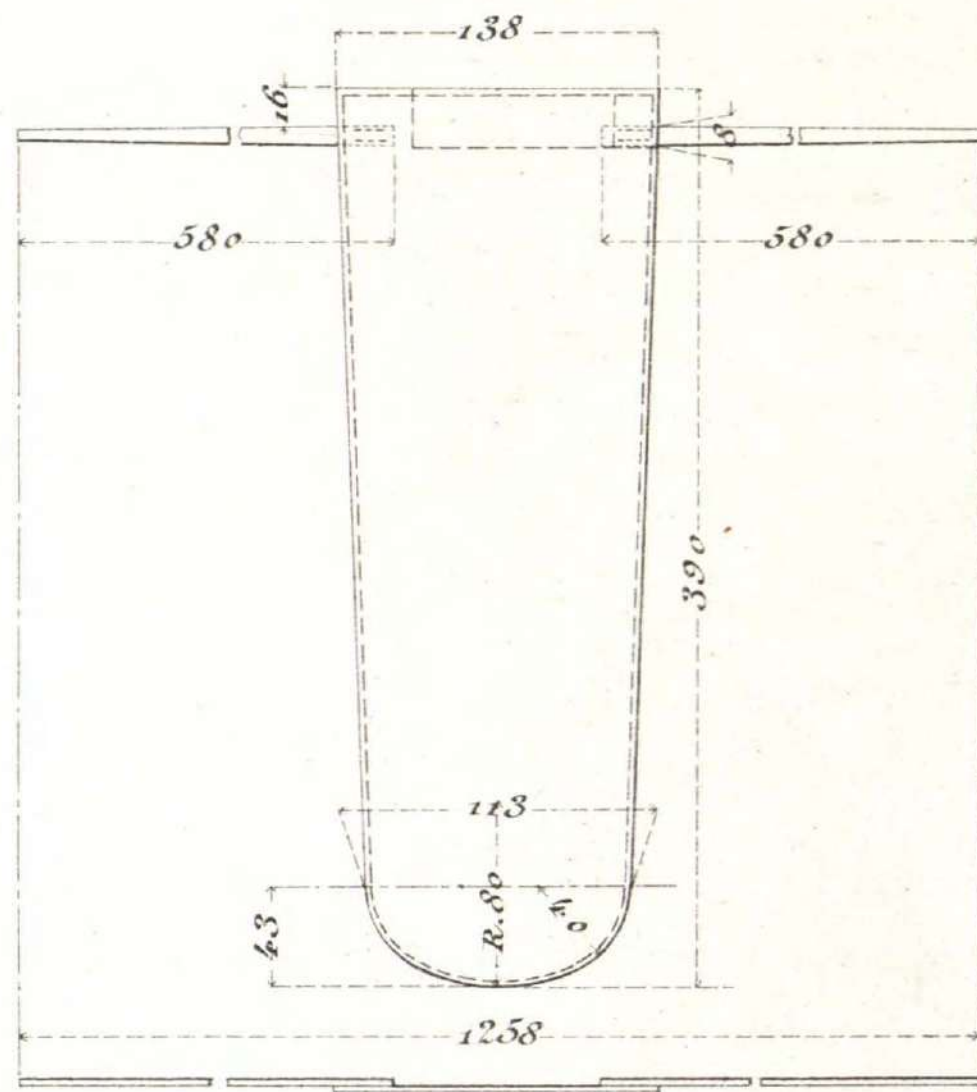

Nota: Hebillaje y anillas de hierro estañado.

# EQUIPO Y MONTURA PARA LOS REGIMIENTOS MONTADOS DEL ARMA DE ARTILLERÍA Md. 1914.

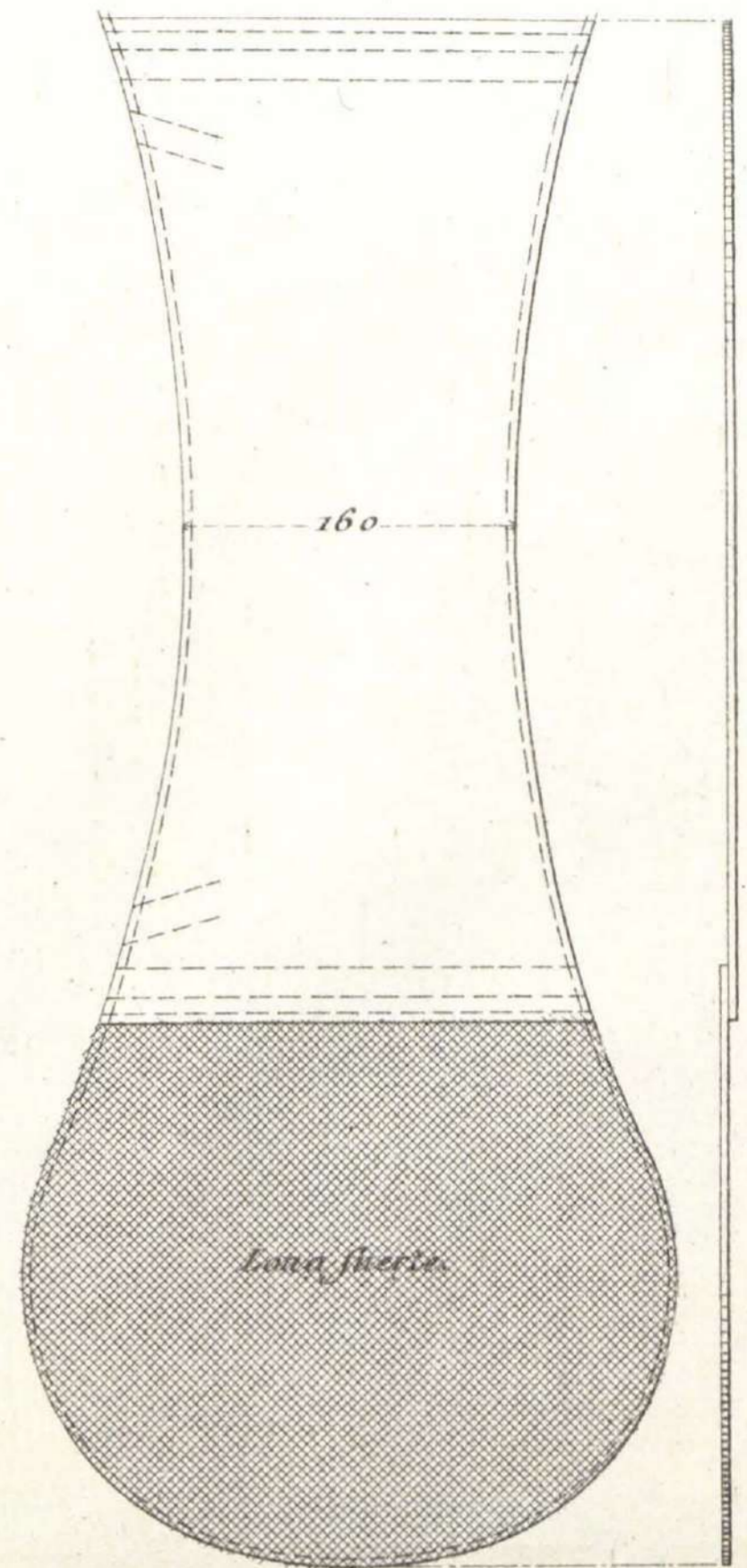
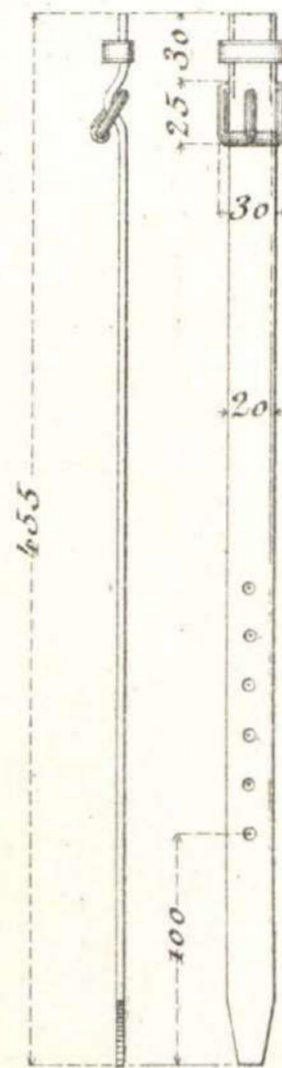
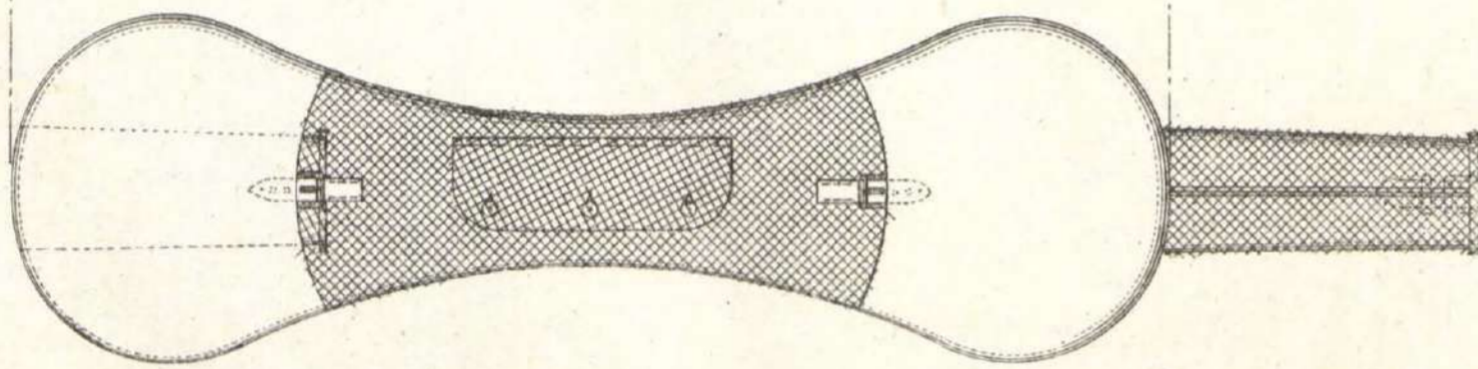
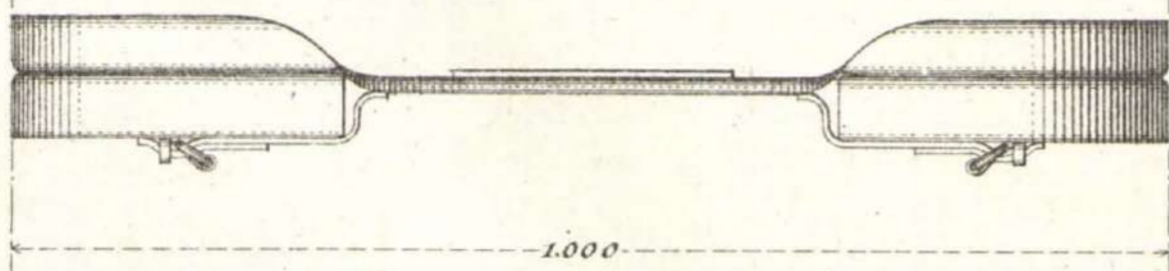
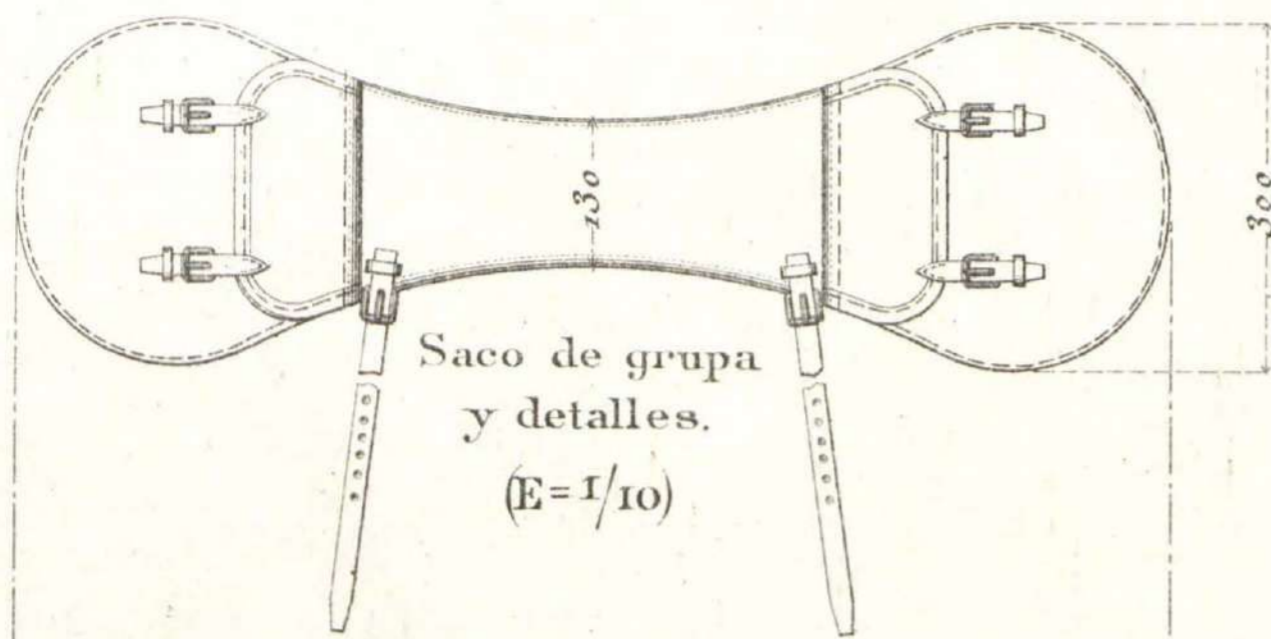

Escala para los detalles. 1/5.

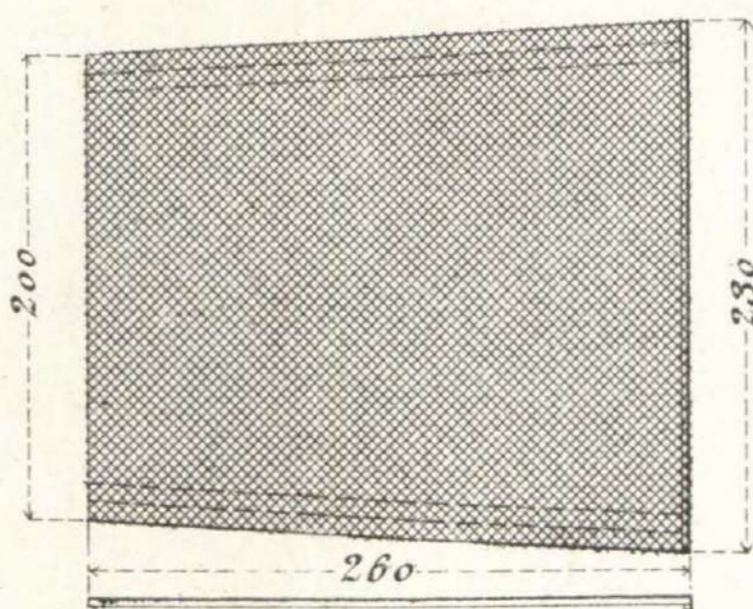
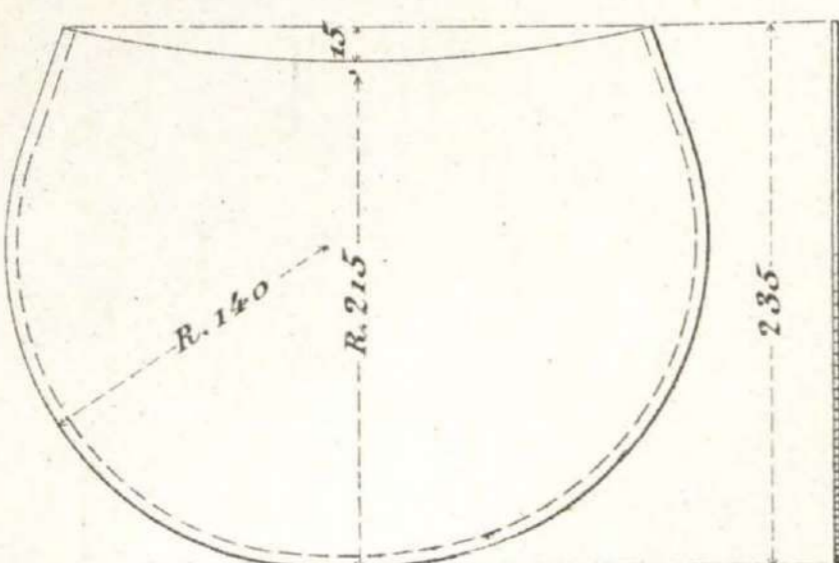
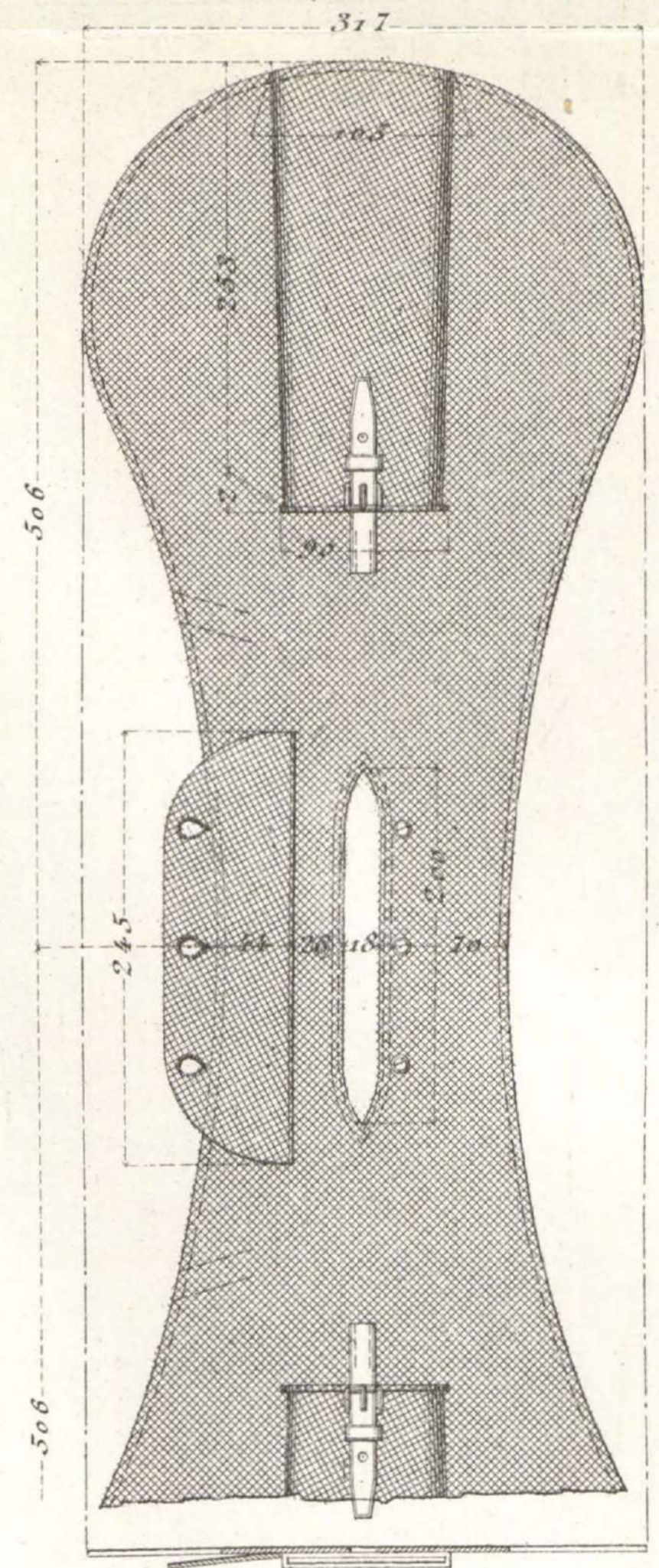
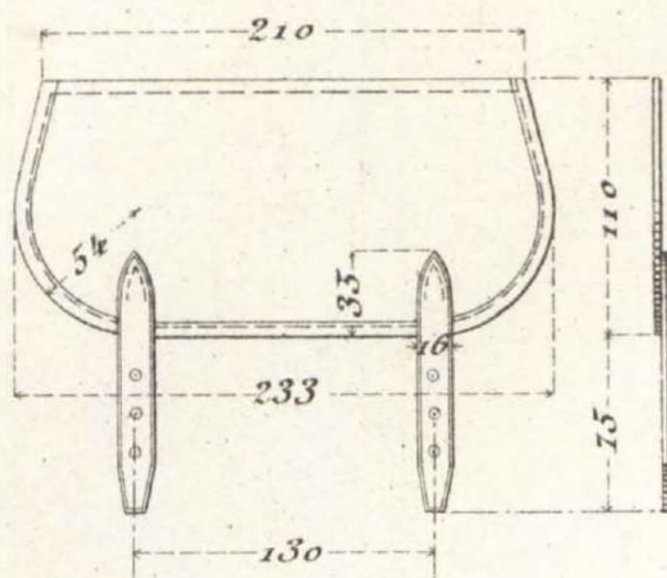
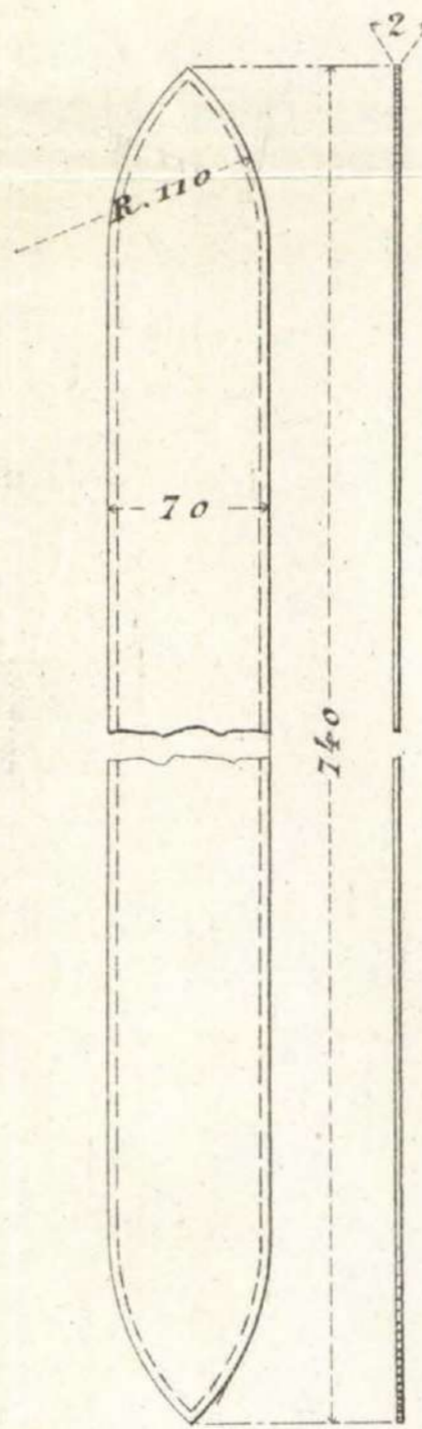
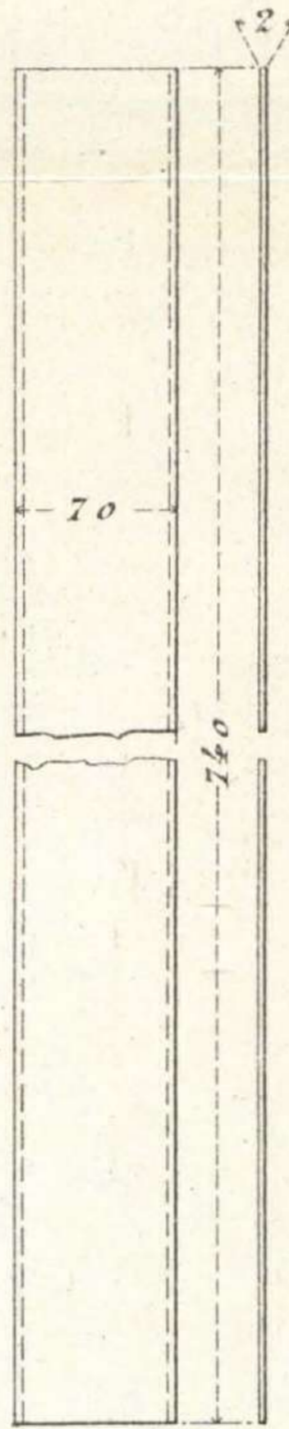
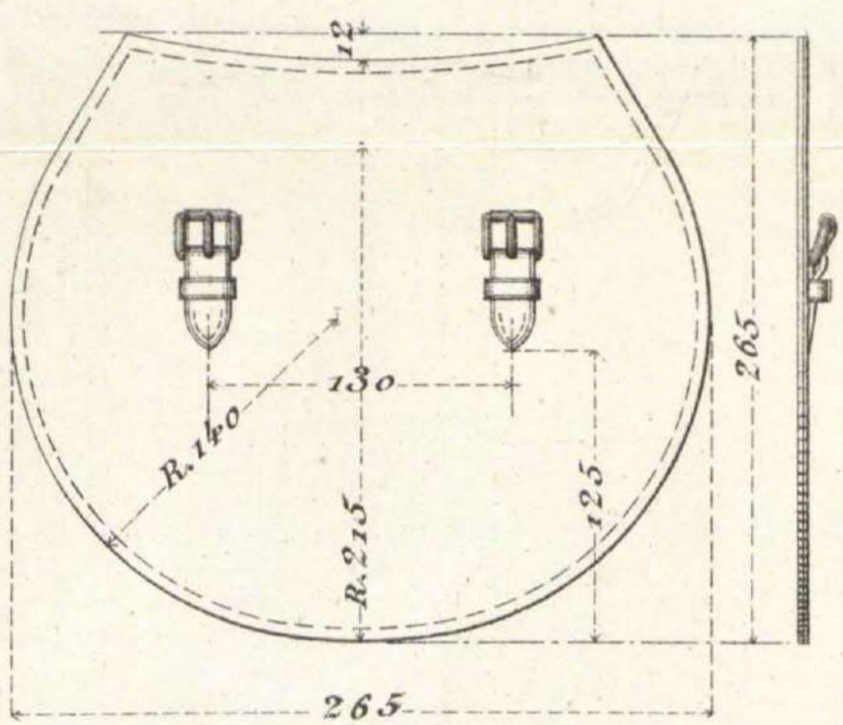

Nota: Hebillaje y anillas de hierro estañado.

# CAJON DE EMPAQUE.

PARA TRANSPORTE DE CARTUCHOS PARA C. CP<sup>NA</sup> 7'5 Cm.  
Escala 2/10.

Sección A.B.-C.D.-E.F.

Sección G.H.

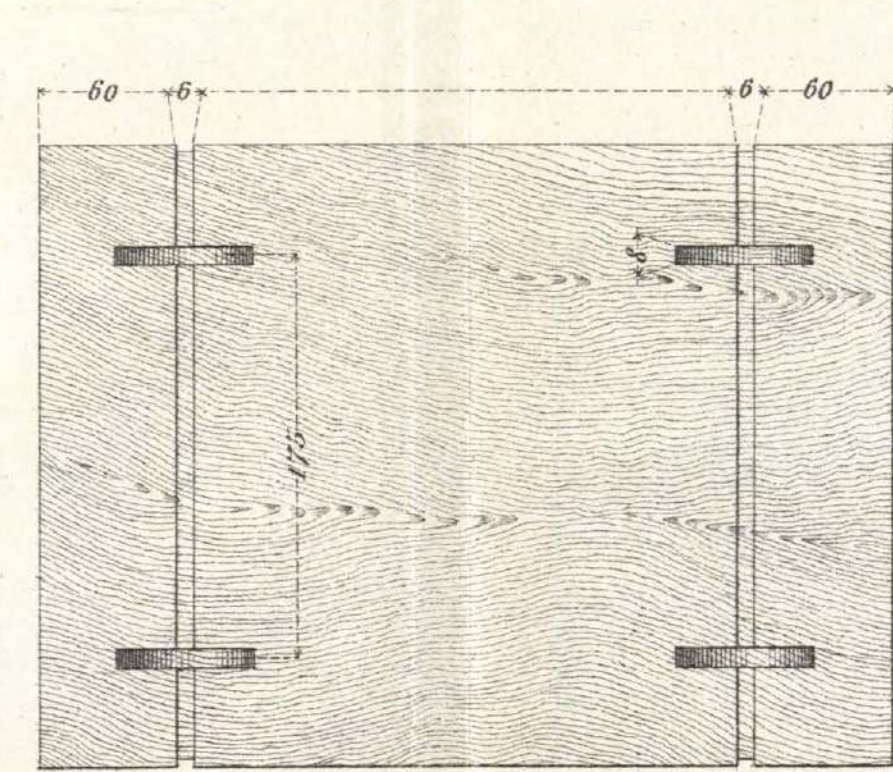
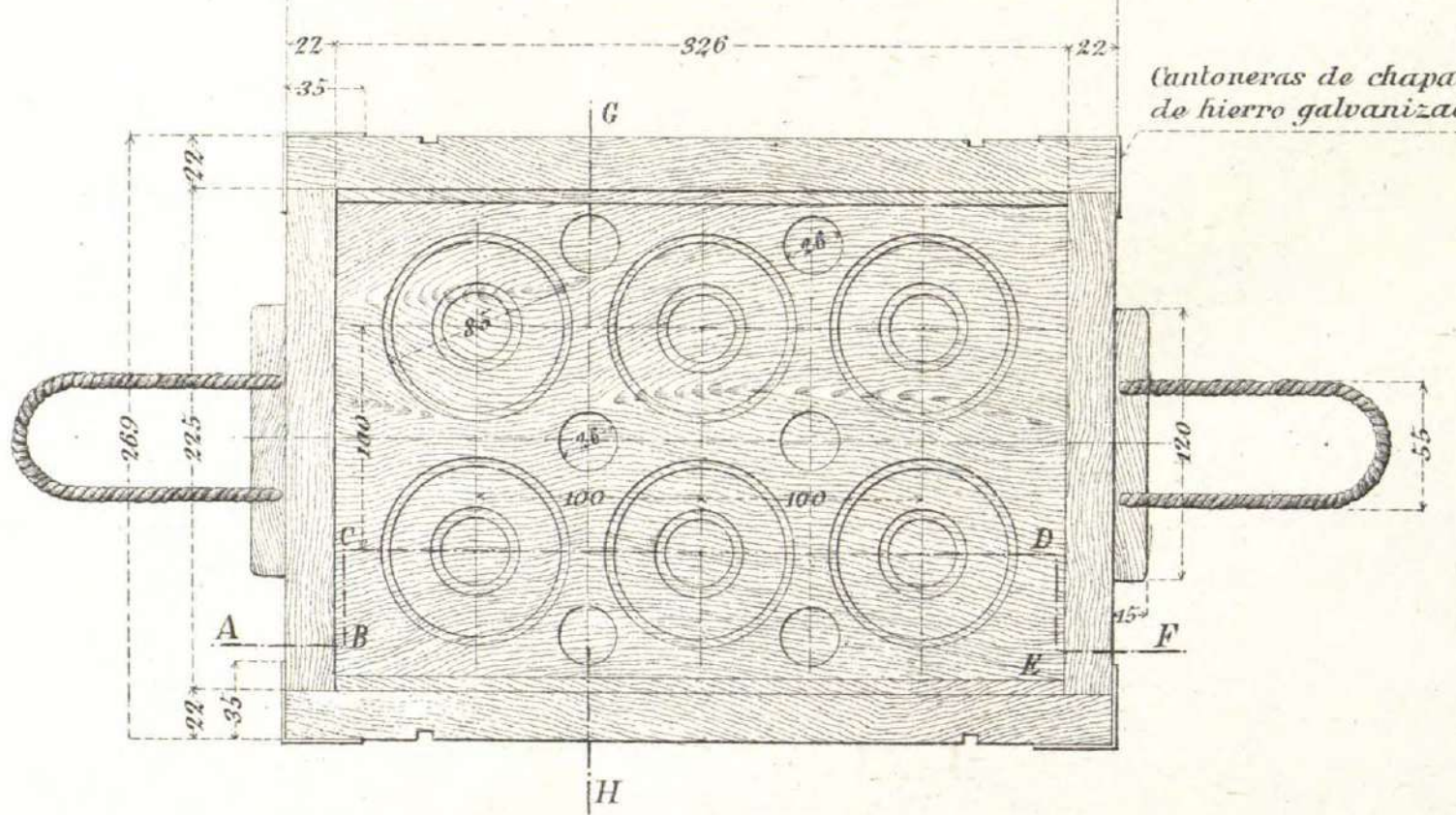
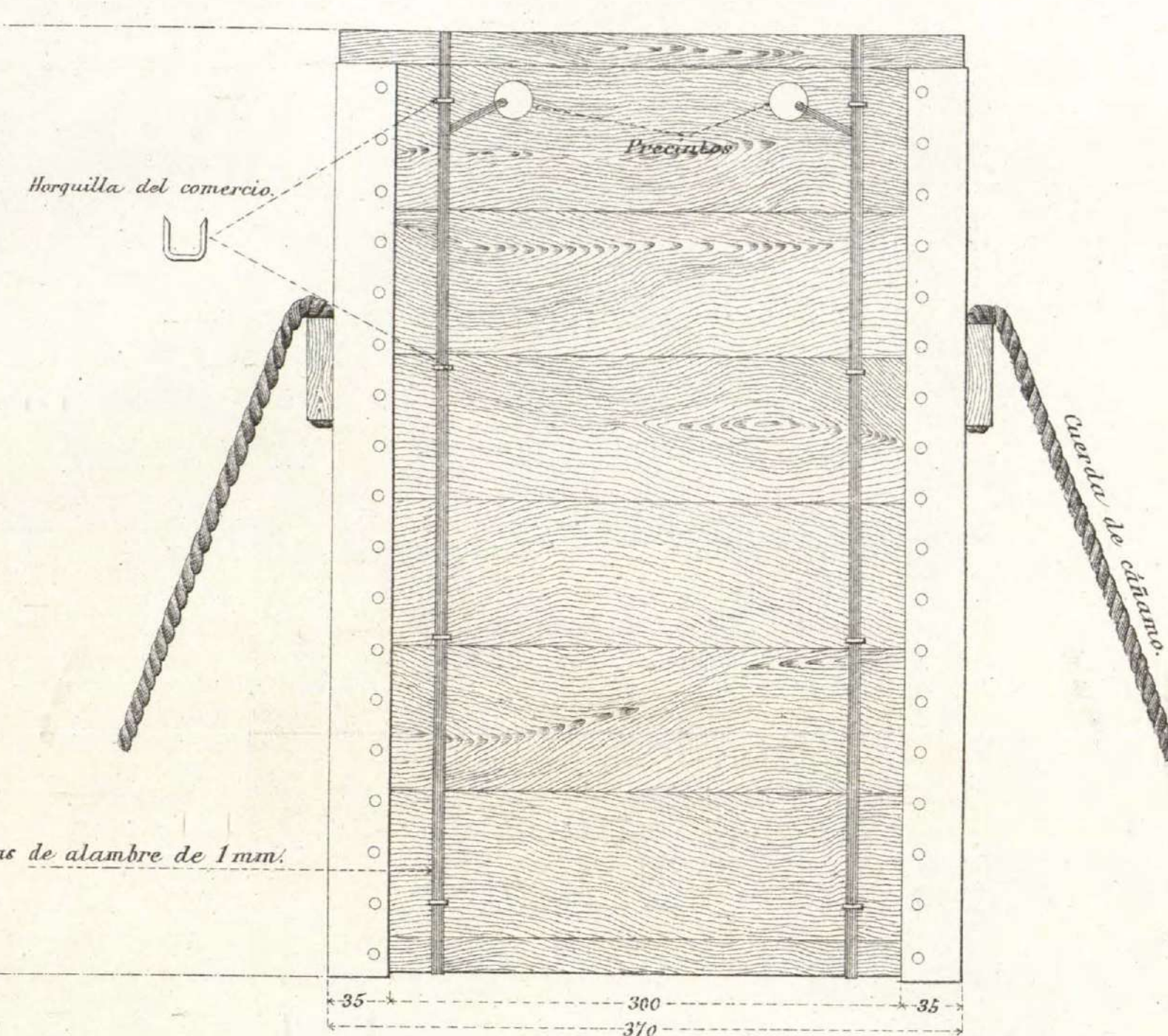
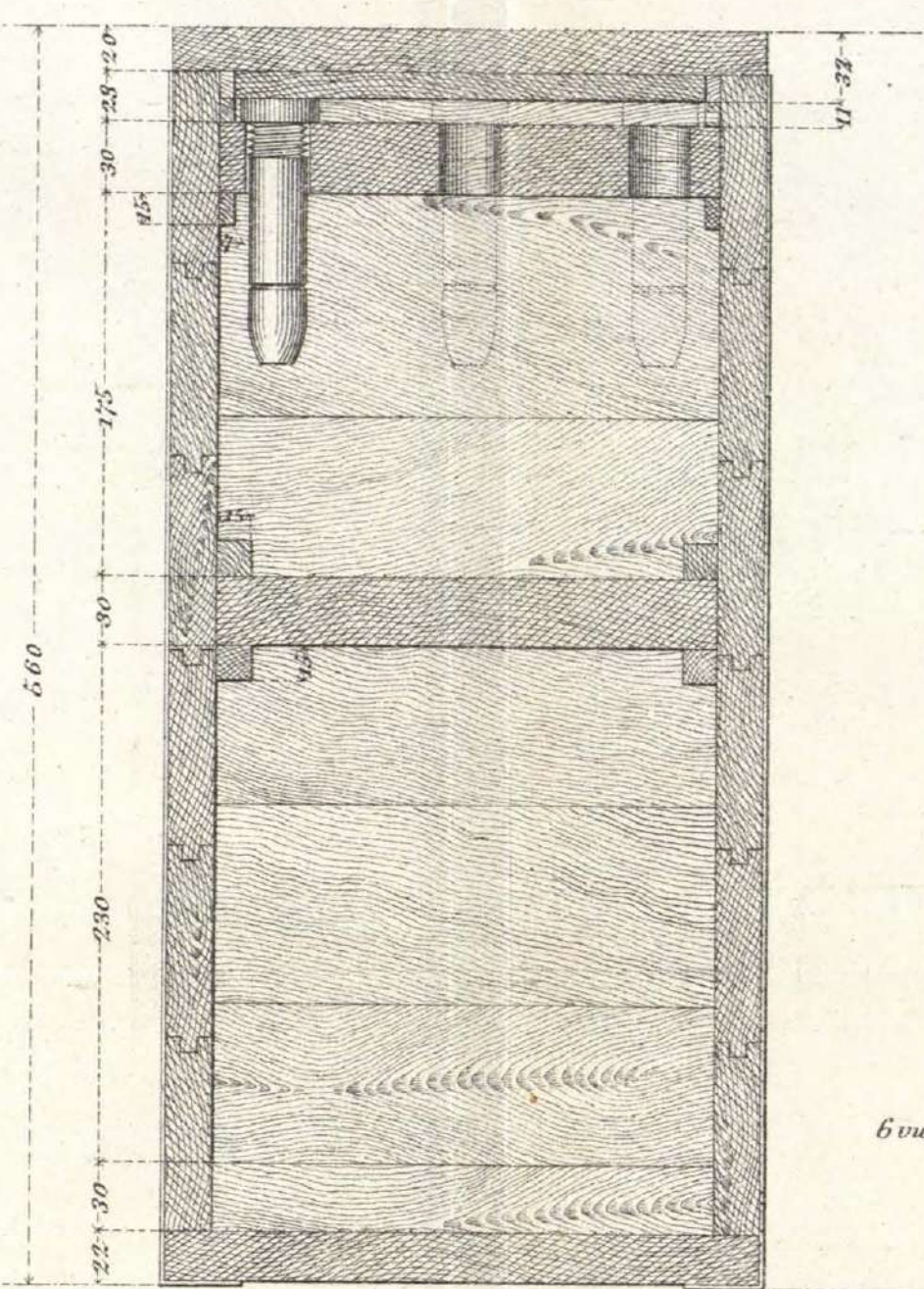
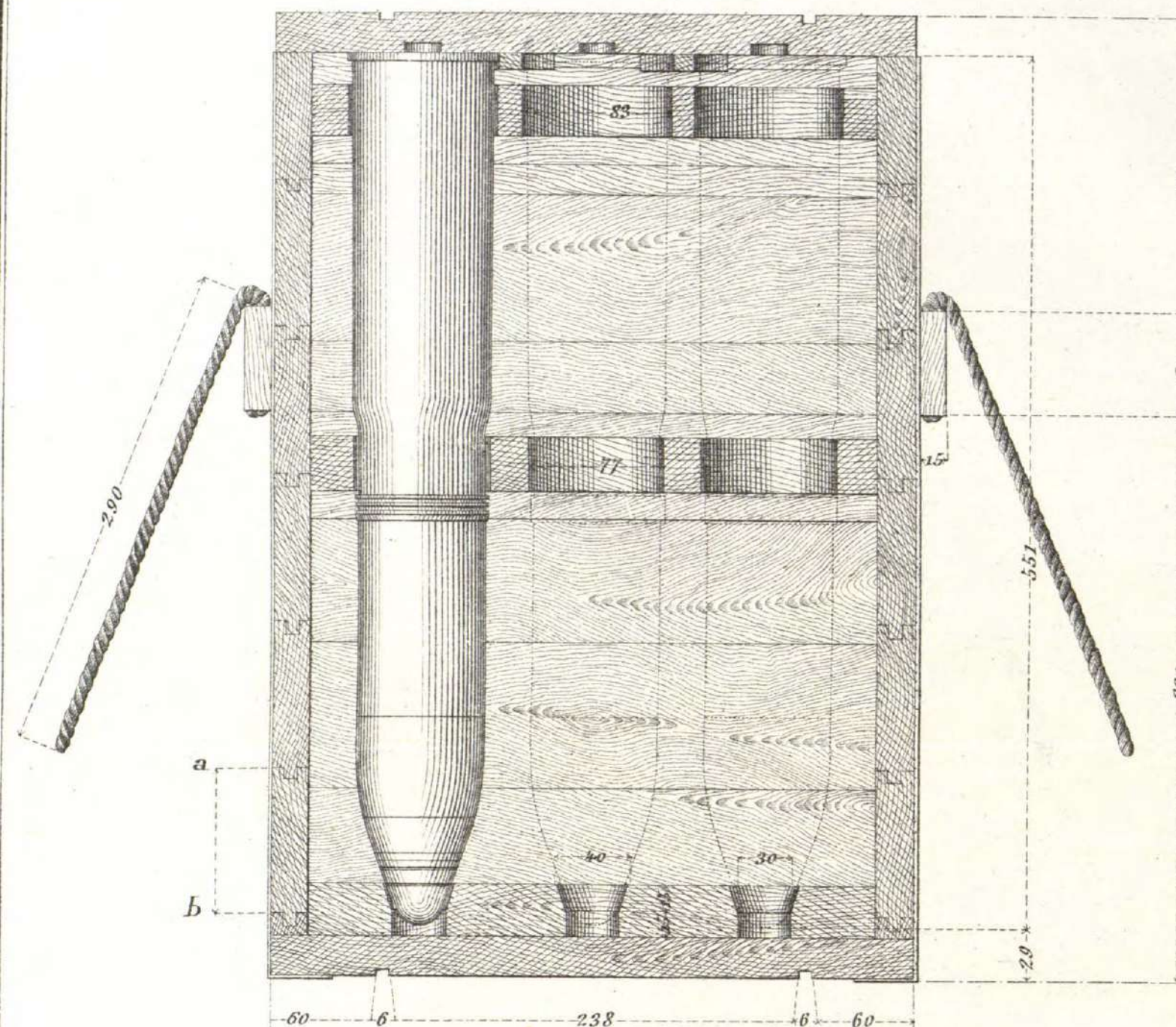

Tapa.  
Sección K.L.

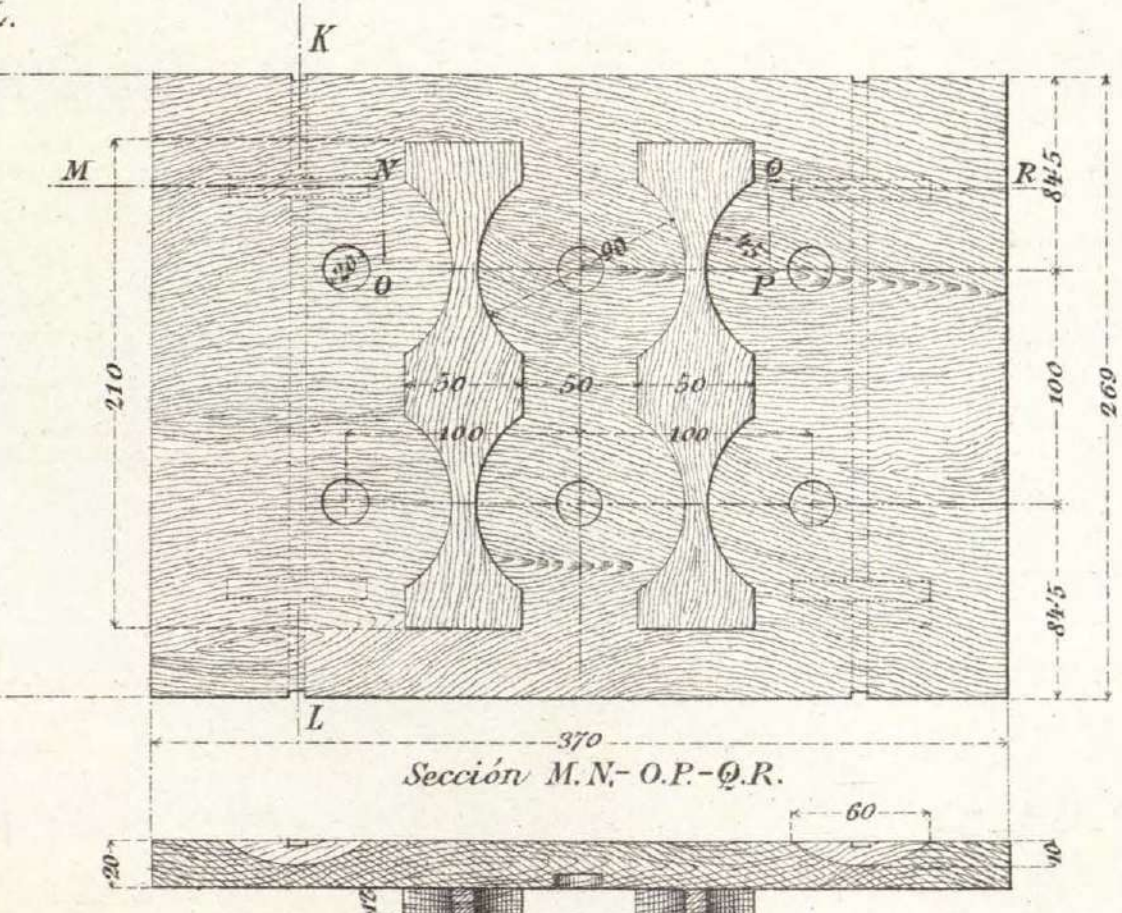

NOTAS: La dimensión a.b. de las tablas de los costados tapa y fondo será la indicada en el plano u otra mayor.  
Las uniones de las tablas de los costados estarán contrapeadas.  
Las tablas de los aljambes de las givas han de estar clavadas a los costados y fondo.



# LLAVE AUTOMÁTICA PARA GRADUAR ESPOLETAS DE TIEMPOS DE 47" Md. 1913

Escala 1/1

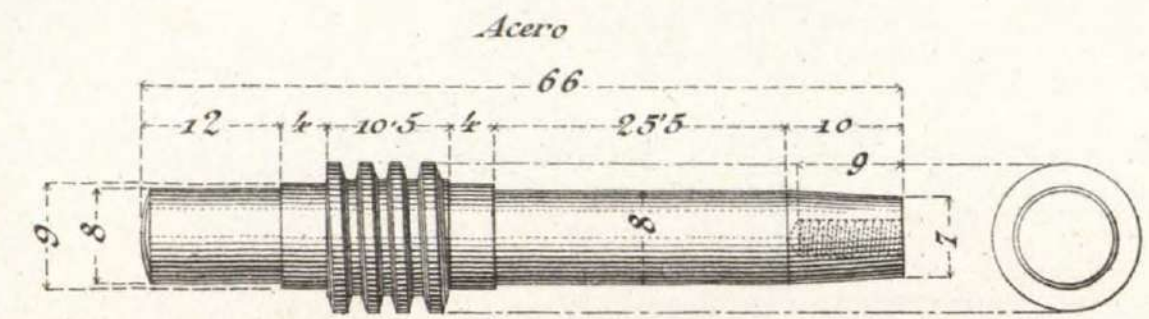
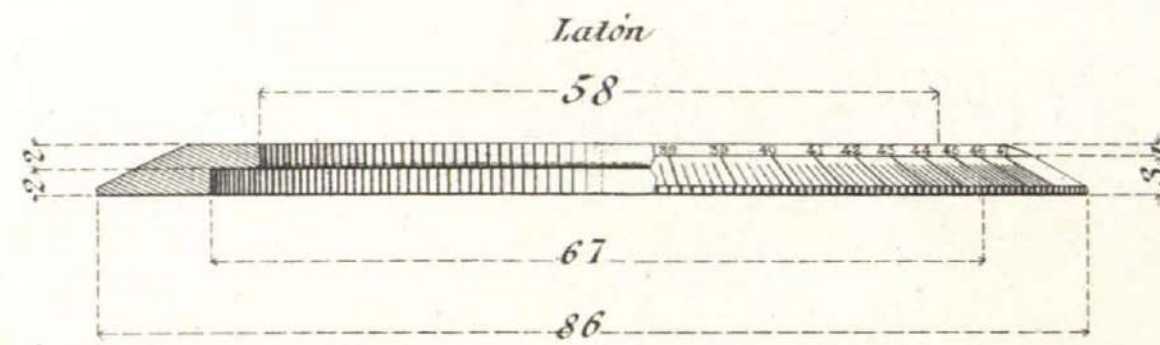
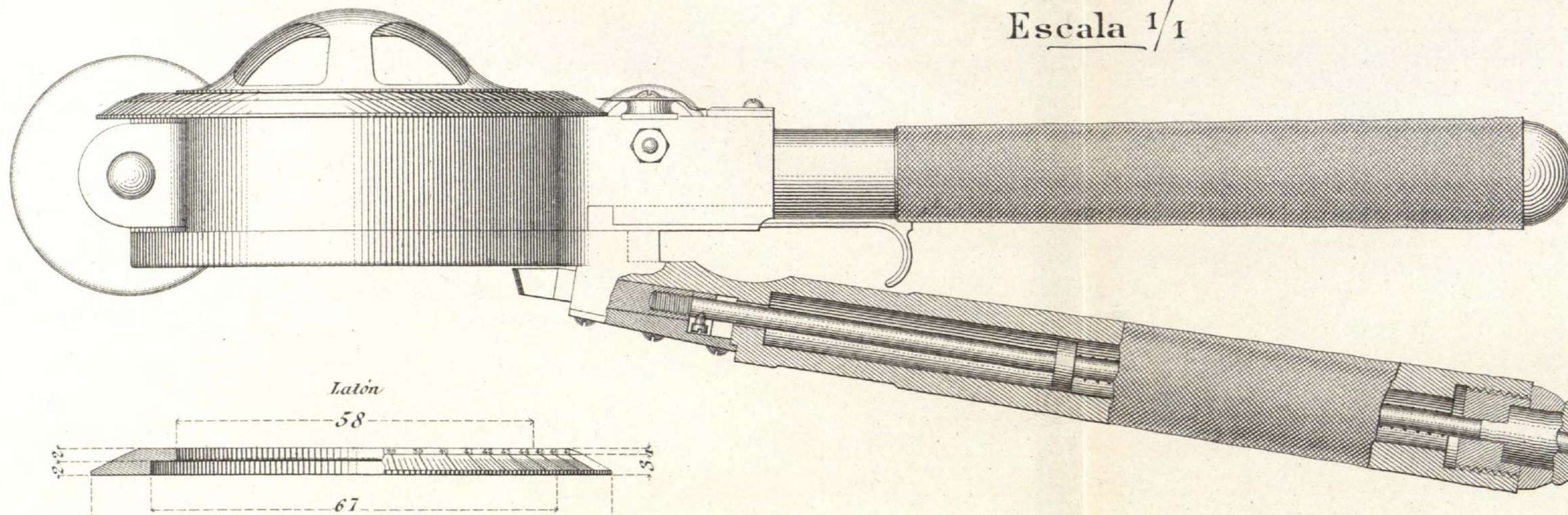

**Rosca**

Díametro mayor	13
id. menor	10
id. del círculo primitivo	11' 7-16
Paso	3' 115

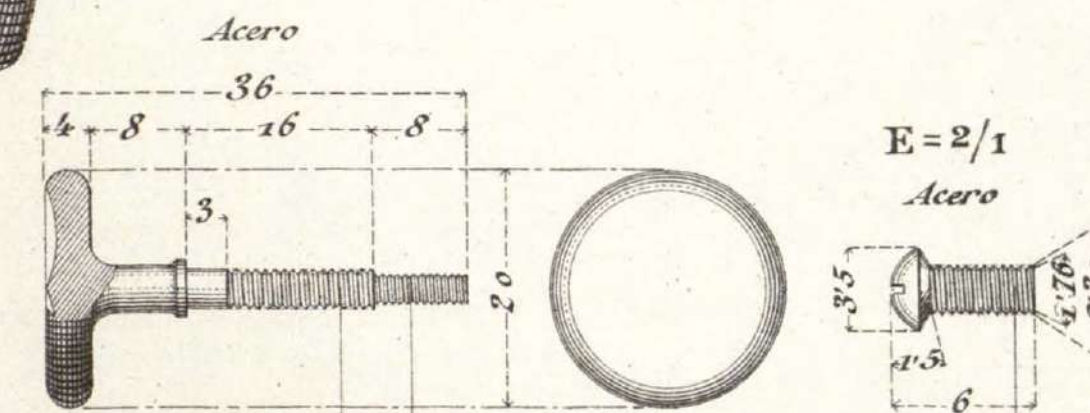
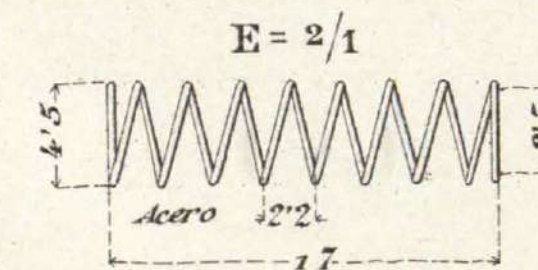
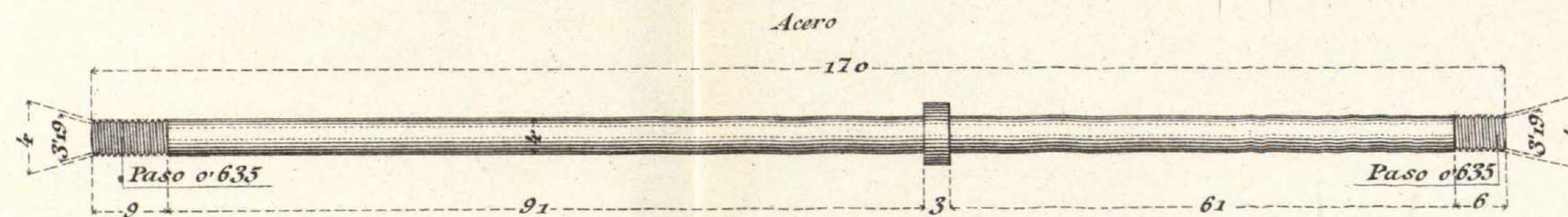
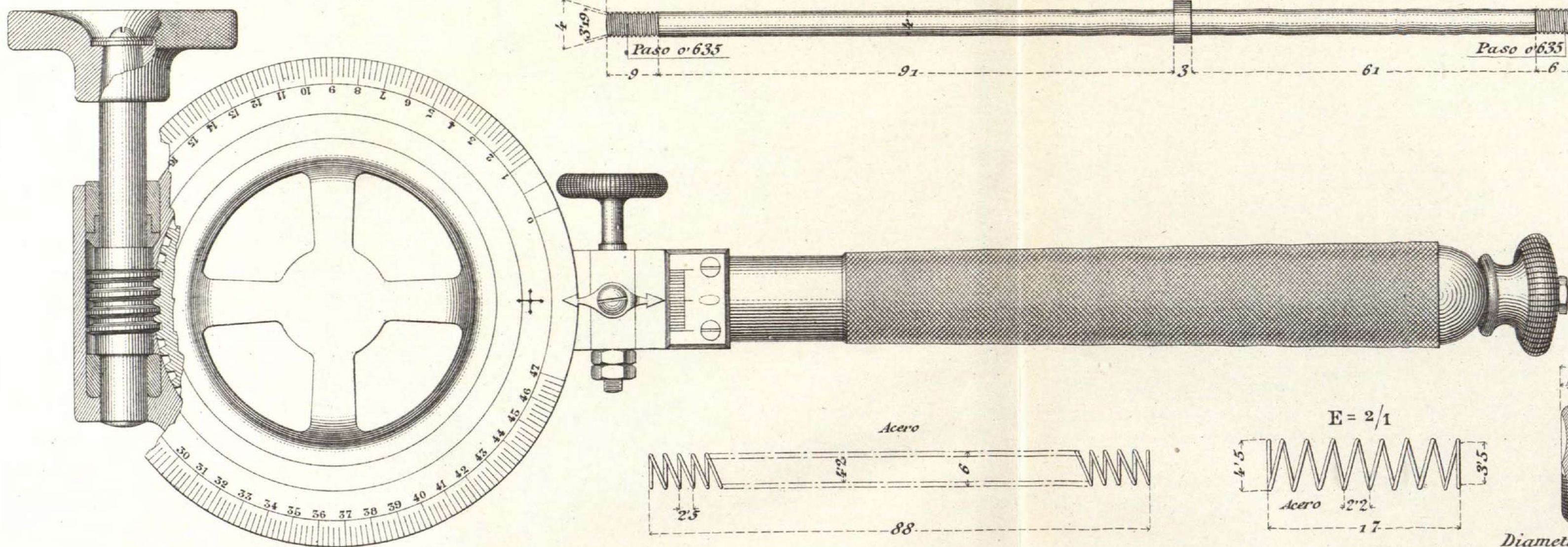
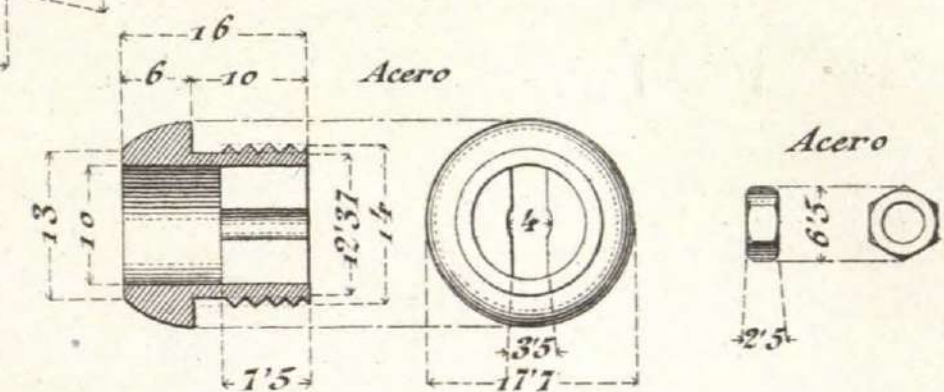
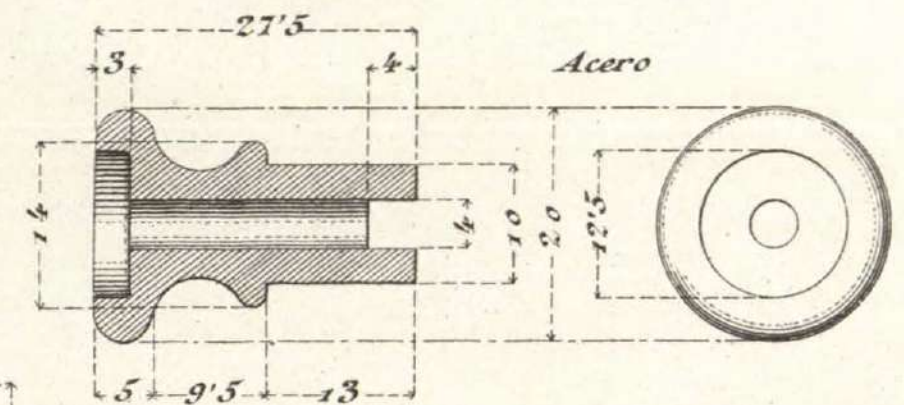
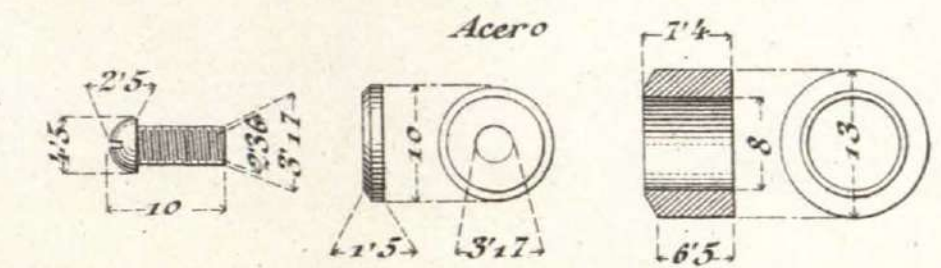

Díametro mayor	3'85
id. menor	3
Paso	0'635
Díametro mayor	3'17
id. menor	2'36
Paso	0'635
Paso	0'423







# CARRO DE BATERIA NÚMERO 1

Escala 1/15

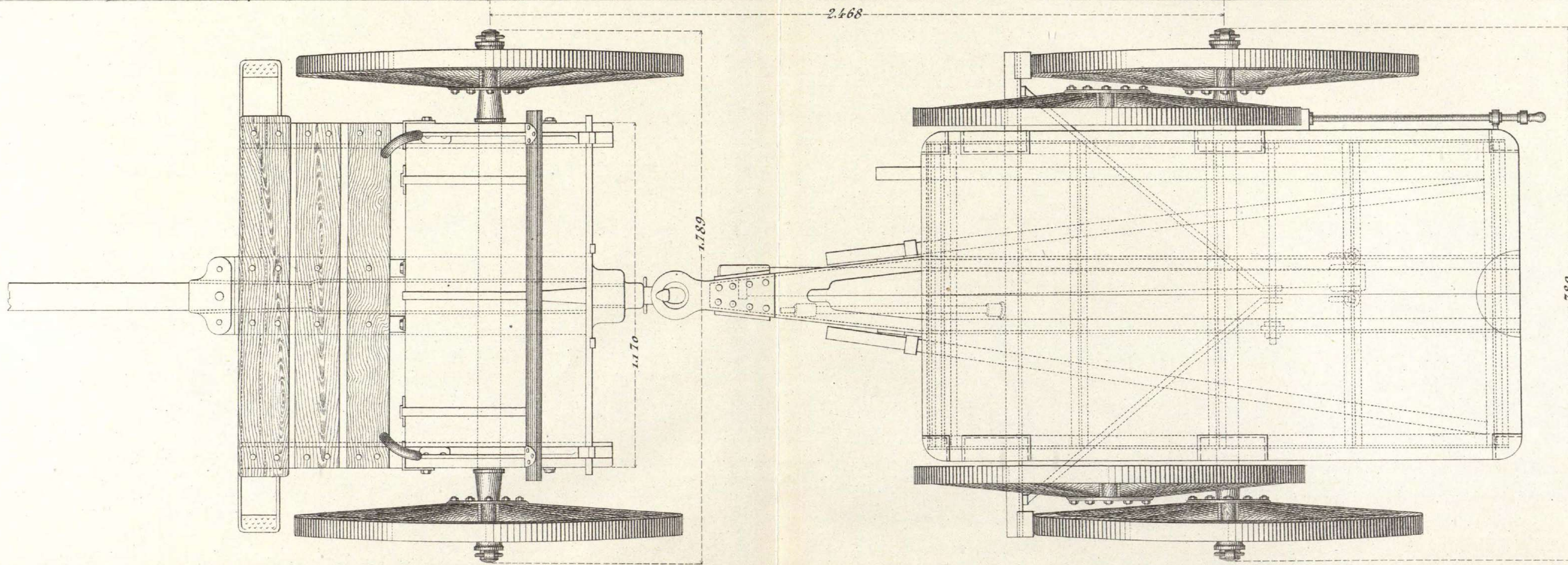
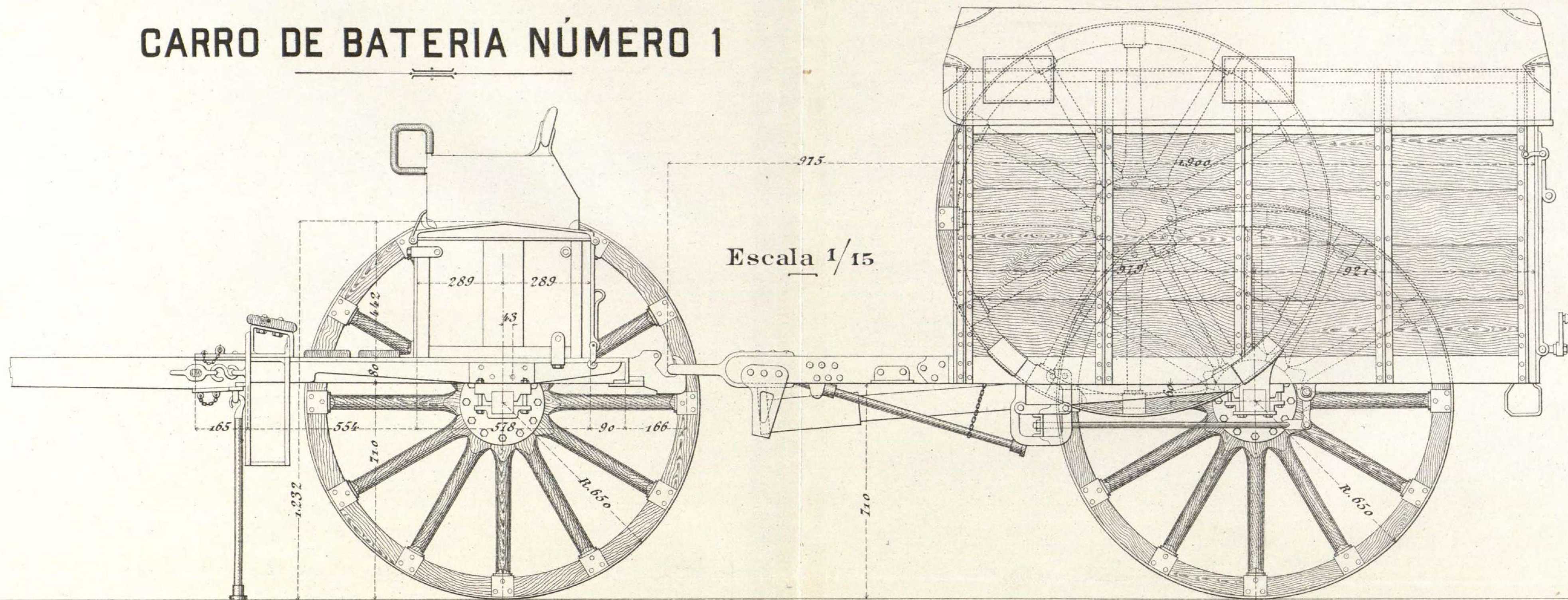



# CARRO DE BATERÍA NÚMERO 1.

### Cabecero posterior. (E=2/10.)

Acero suave

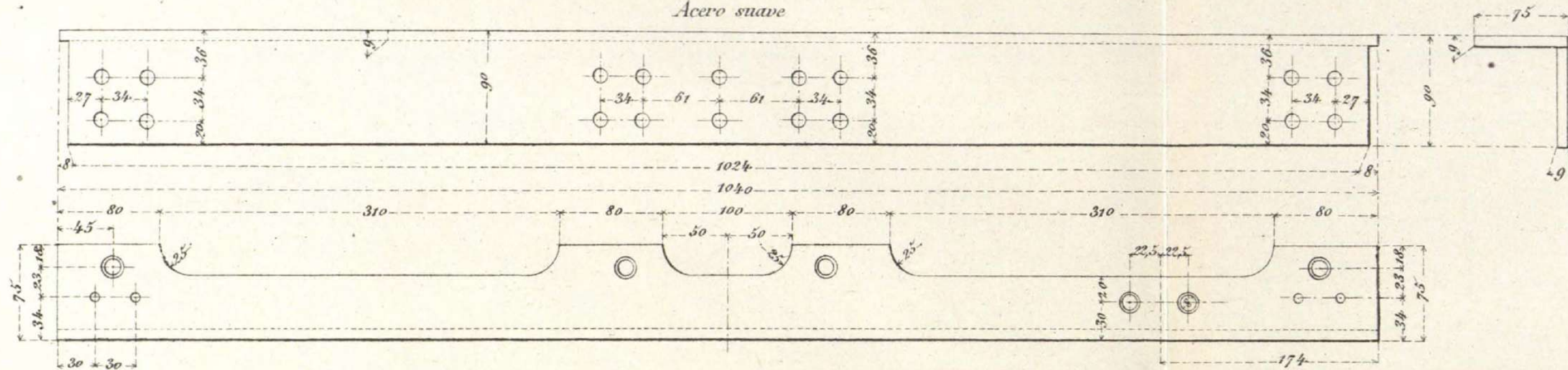

### Soporte del tentemozo.

Acero suave

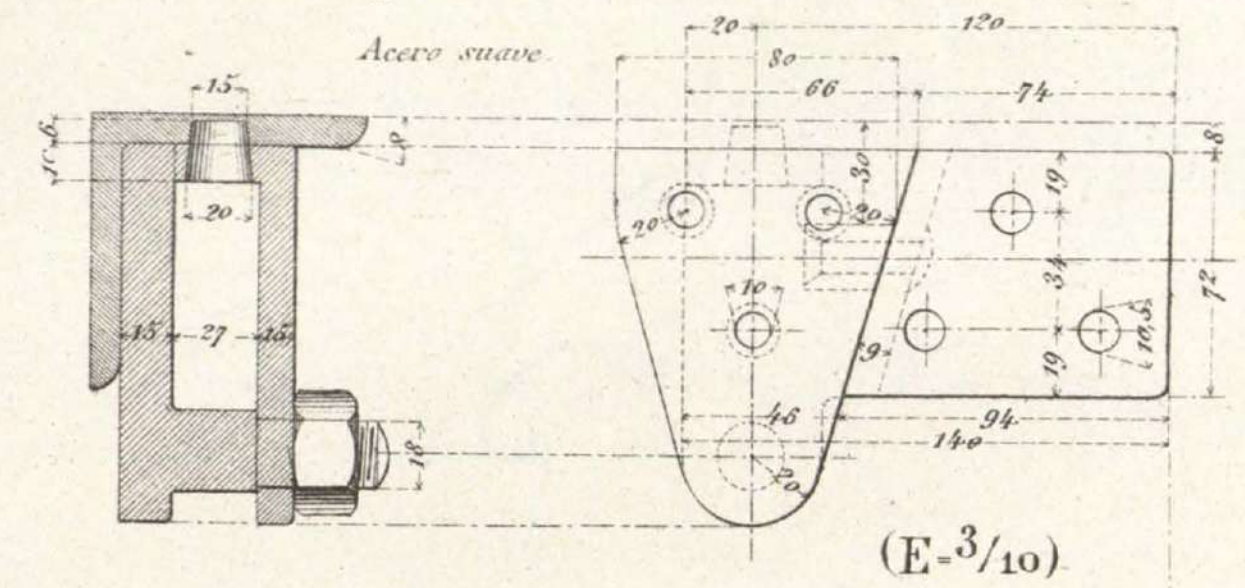

### Cabecero anterior. (E=2/10.)

Acero suave.

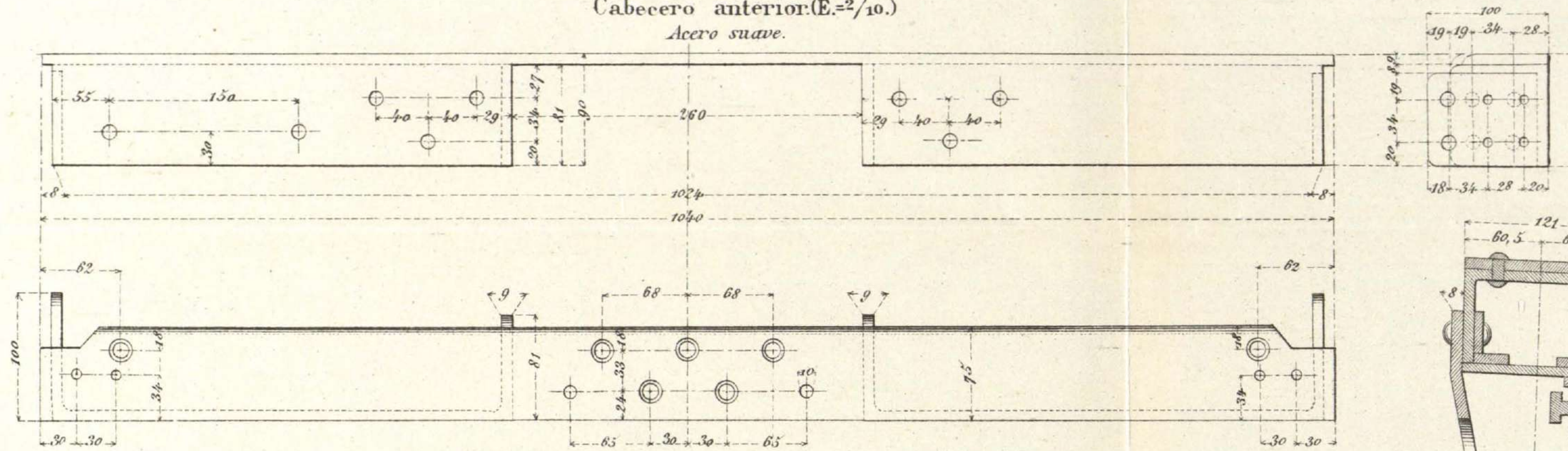

### Mastil. (E=2/10)

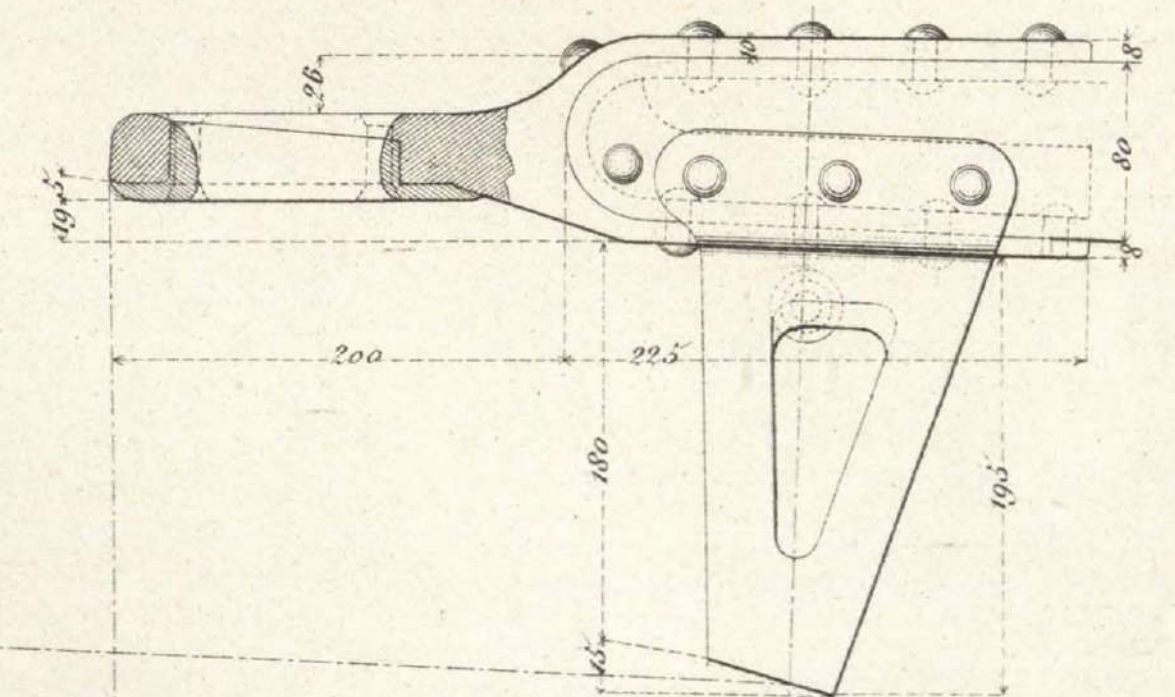

### Tentemozo del retrotren. (E=5/10)

Acero suave.

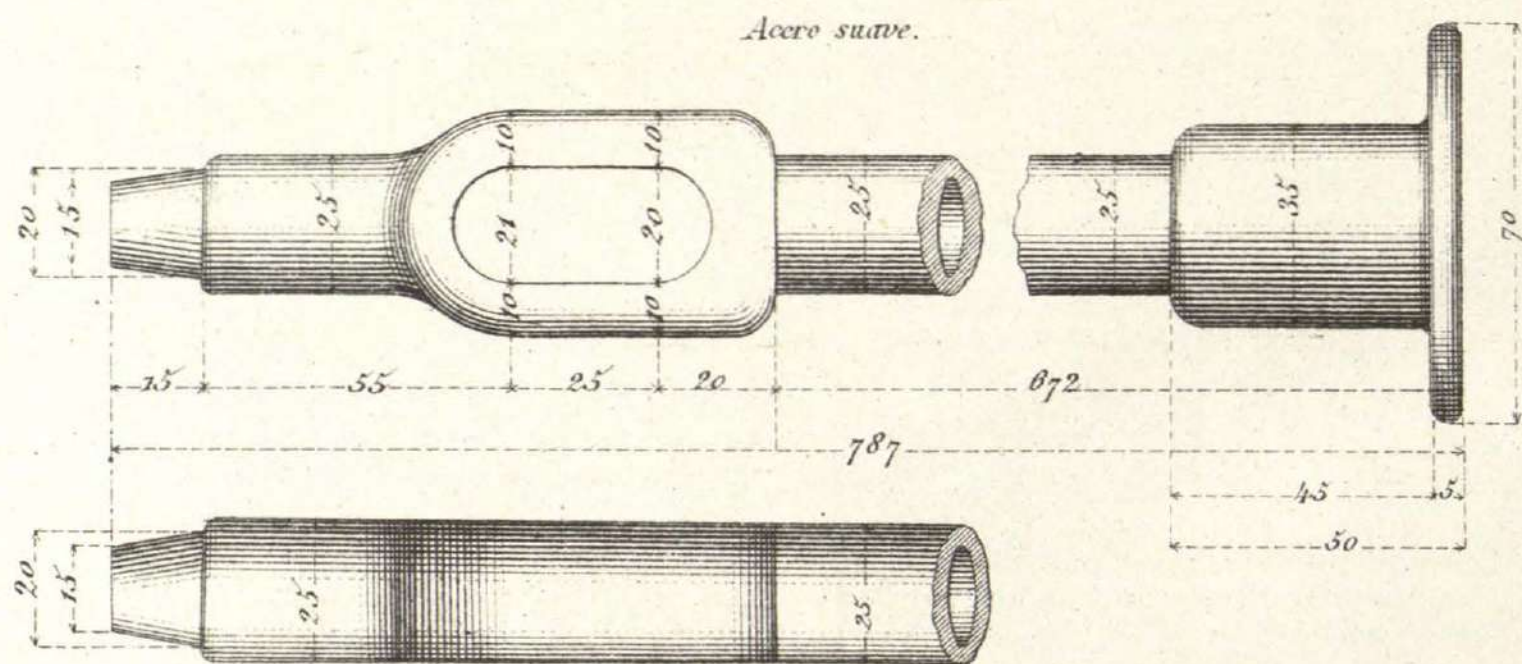

### Gancho y cadenilla de suspensión del tentemozo. (E=5/10.)

Acero suave.

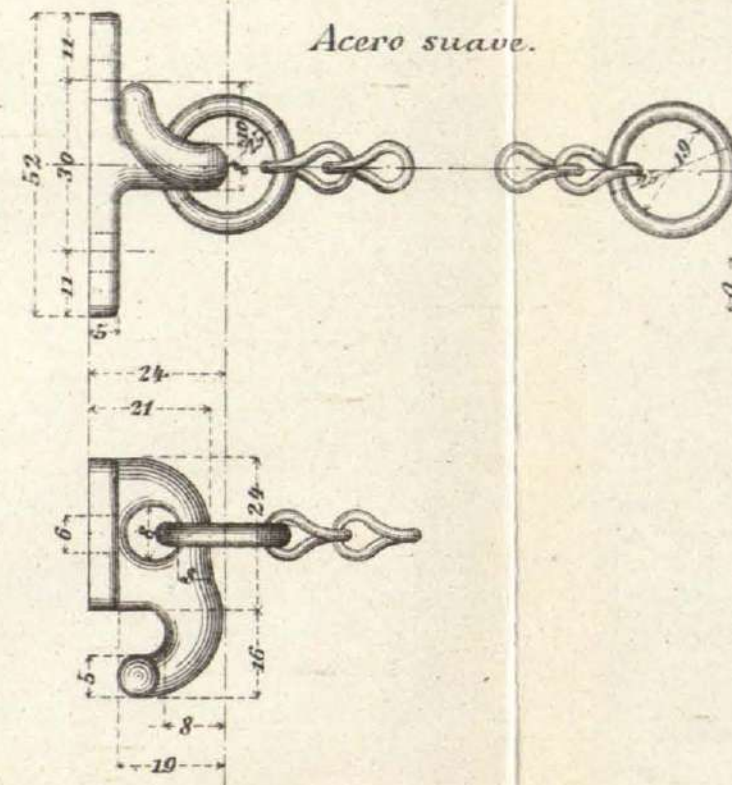

### Telera de la viqueta. (E=15/10)

Acero suave.

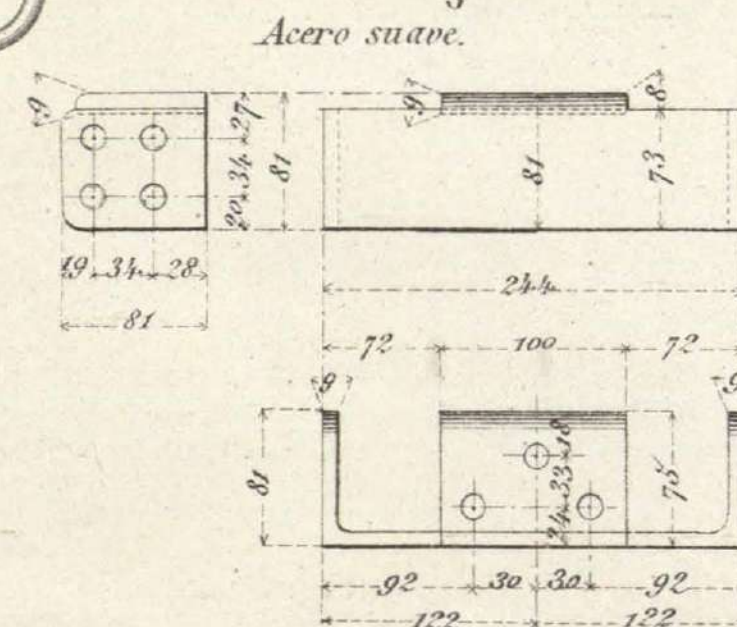

# CARRO DE BATERÍA NUMERO 1.

DETALLES DEL FRENO.  
Escala 3/10.

1 Tuerca  
Acero suave.

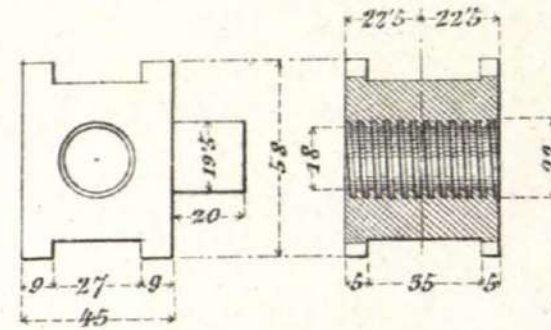

1 Husillo-eje.  
Acero suave



1 Barra. Acero suave.

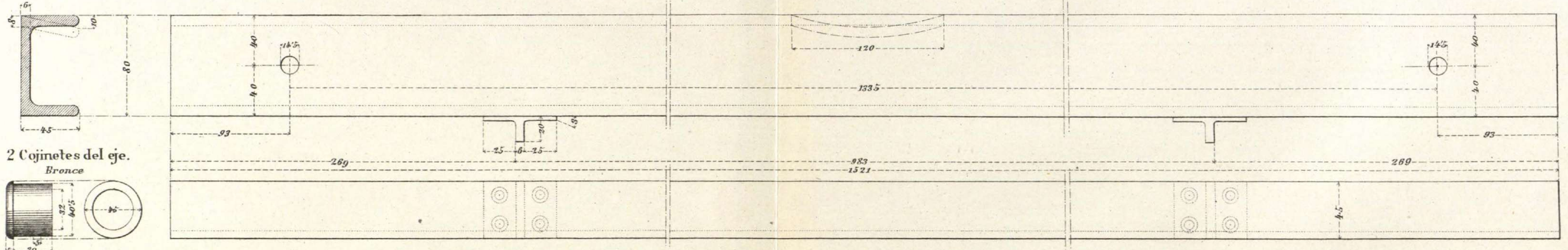

2 Cojinetes del eje.  
Bronce

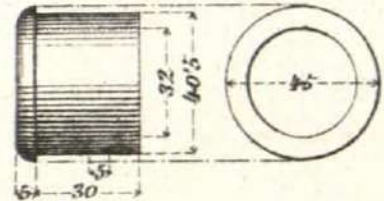

1 Soporte de la tuerca del freno.  
Acero suave.

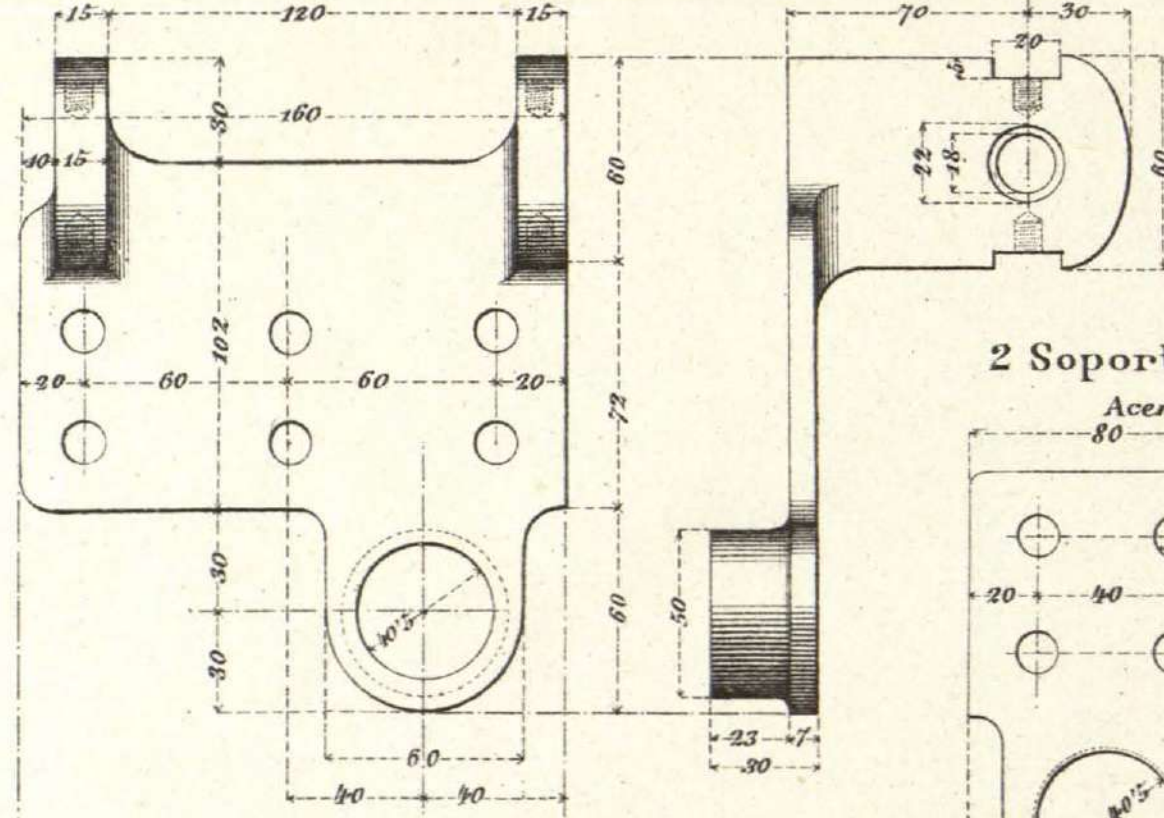

1 Palanca lateral.  
Acero suave.

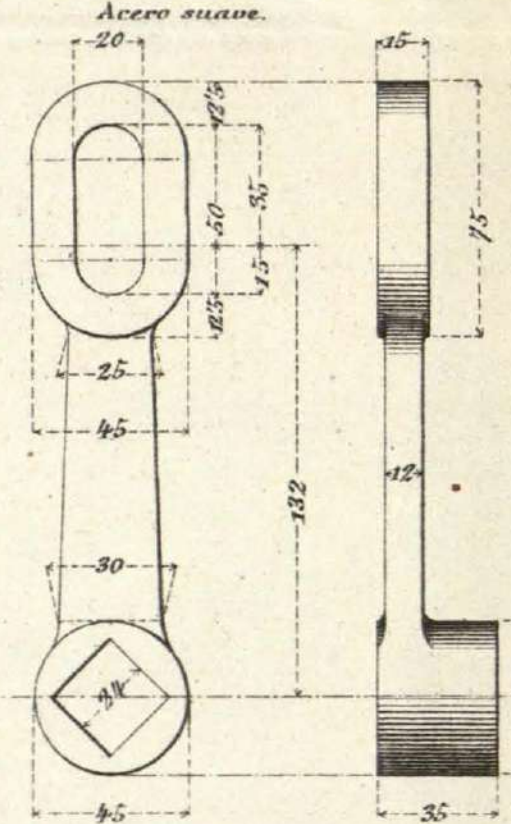

Manivela.

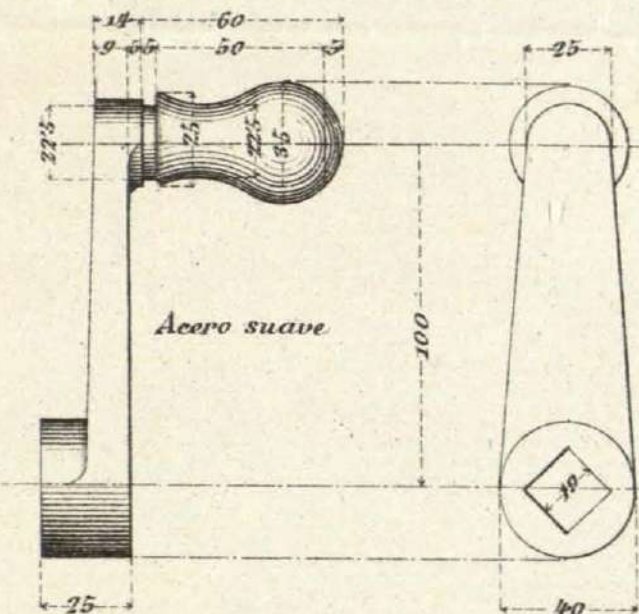

1 Soporte del husillo.  
Acero suave.

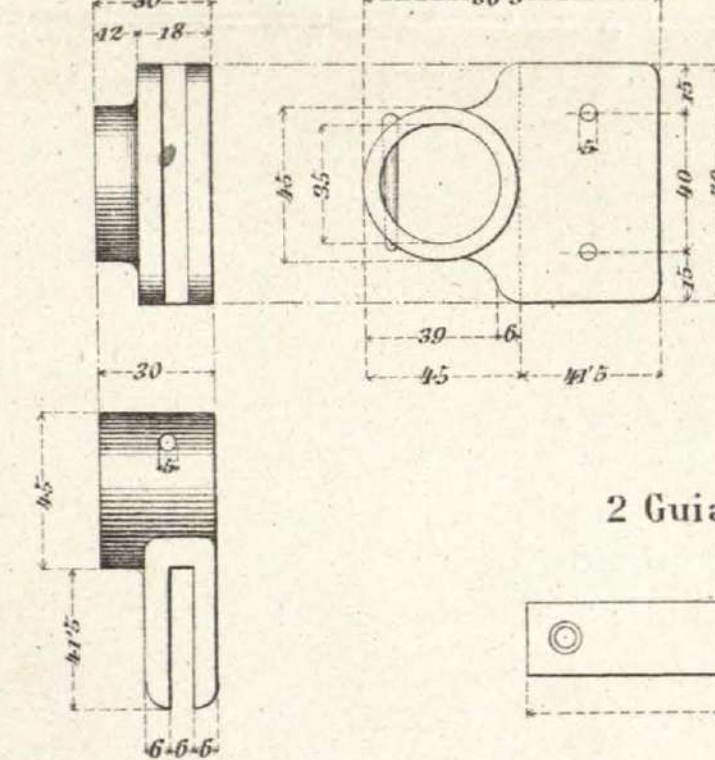

1 Bolon.  
Acero suave.

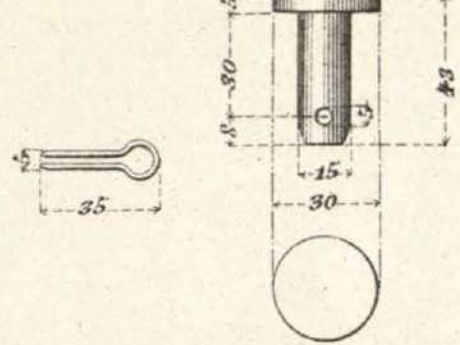

2 Soportes del eje.  
Acero suave.

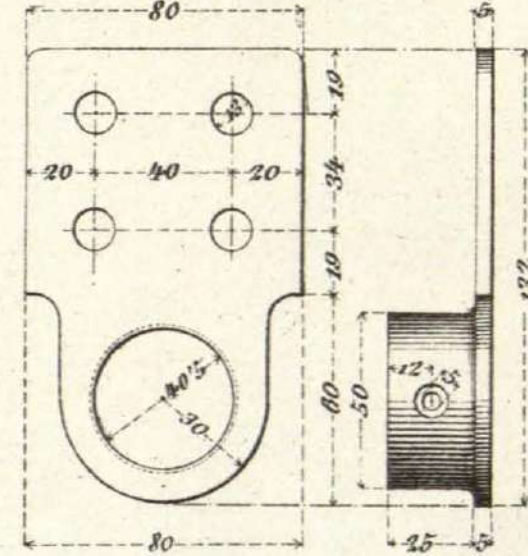

Cojinete del eje.  
Bronce.

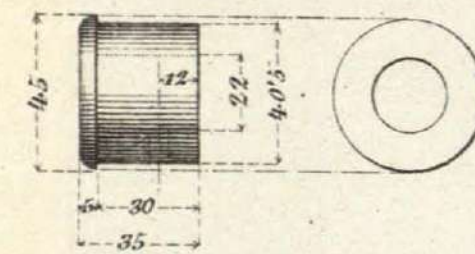

2 Guías de la tuerca.  
Acero suave.

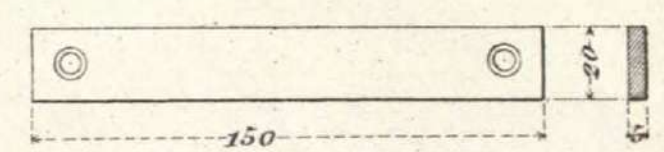

Palanca central.  
Acero suave.

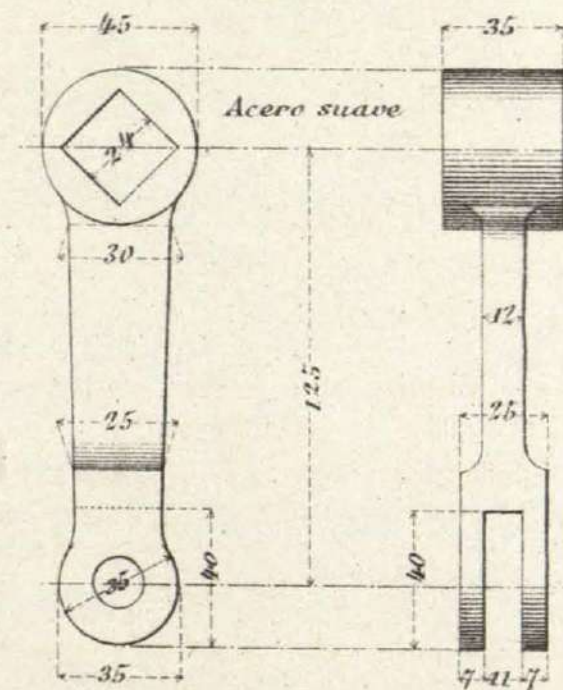

2 Zapatas del freno.  
Acero suave.

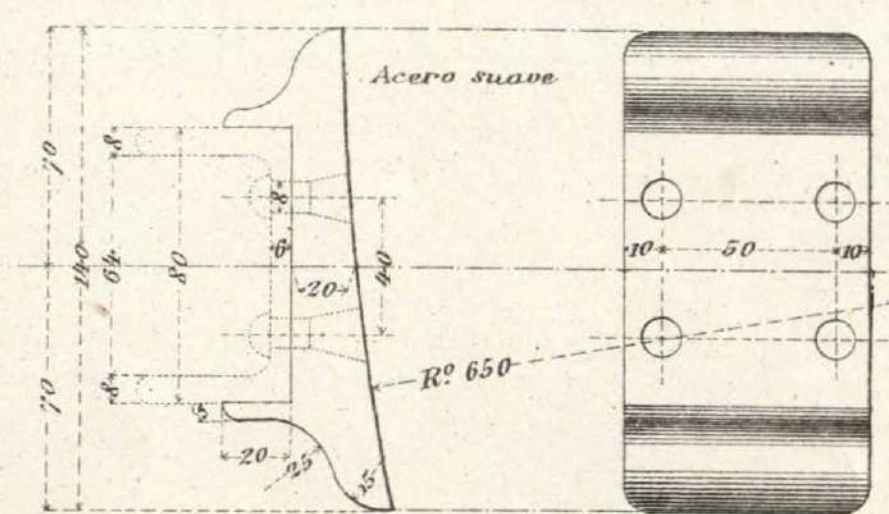

Grapas de sujeción de los lechos.  
Acero suave.

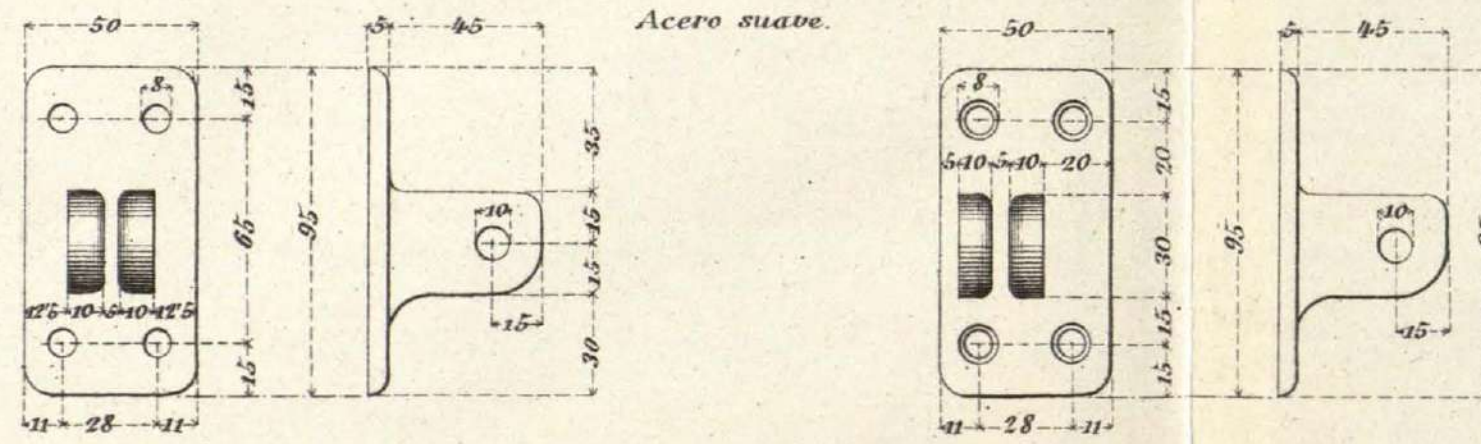





# CARRO DE BATERIA NÚMERO 1.

1 Armadura posterior del toldo. (2/10)

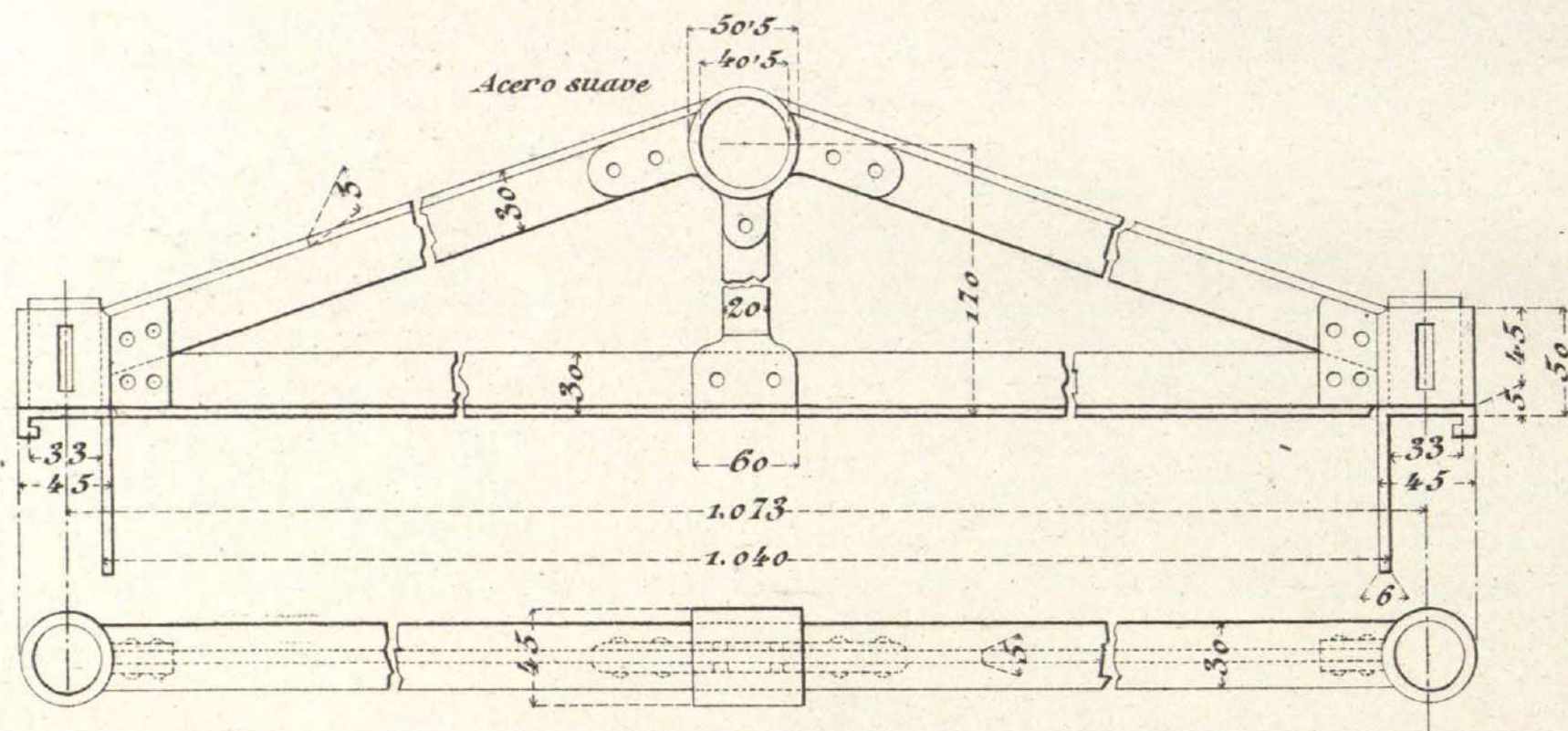

1 Armadura anterior del toldo. (2/10)

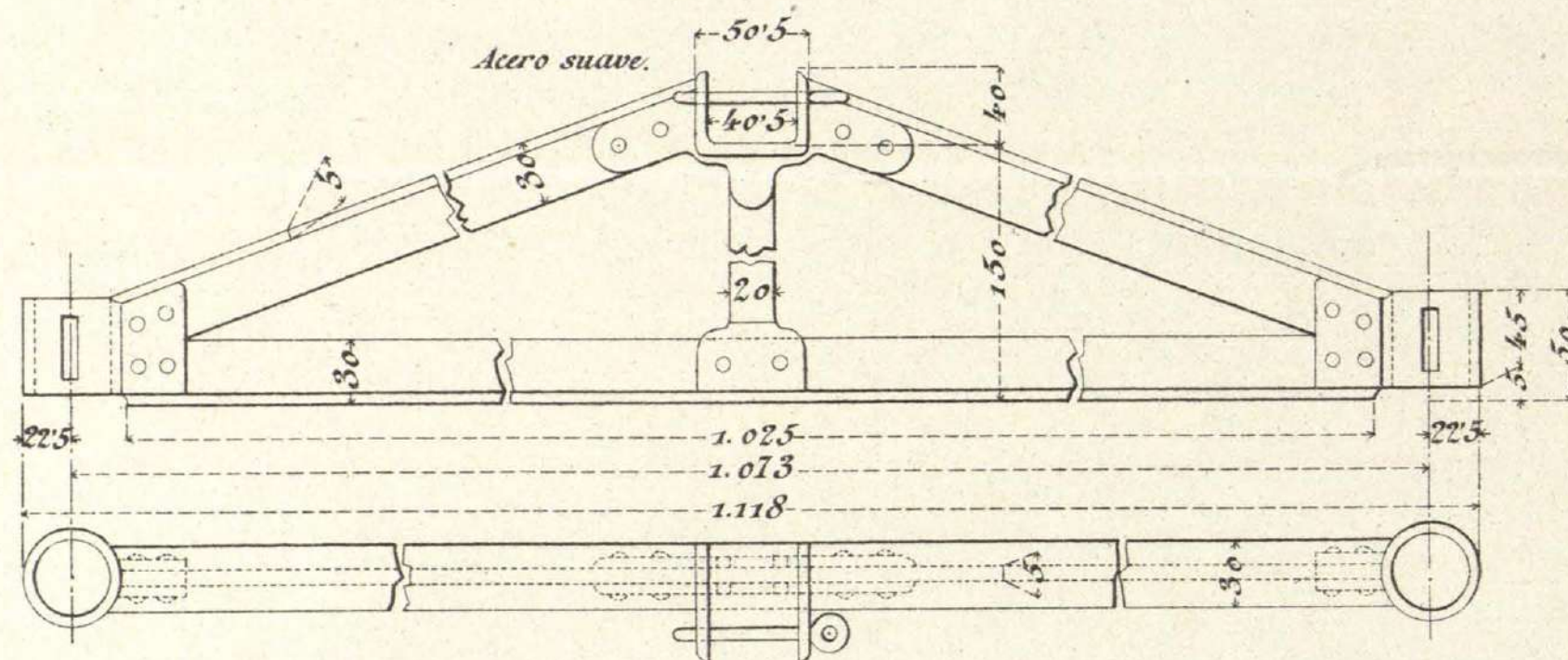

1 Horquilla de la armadura anterior. (4/10)

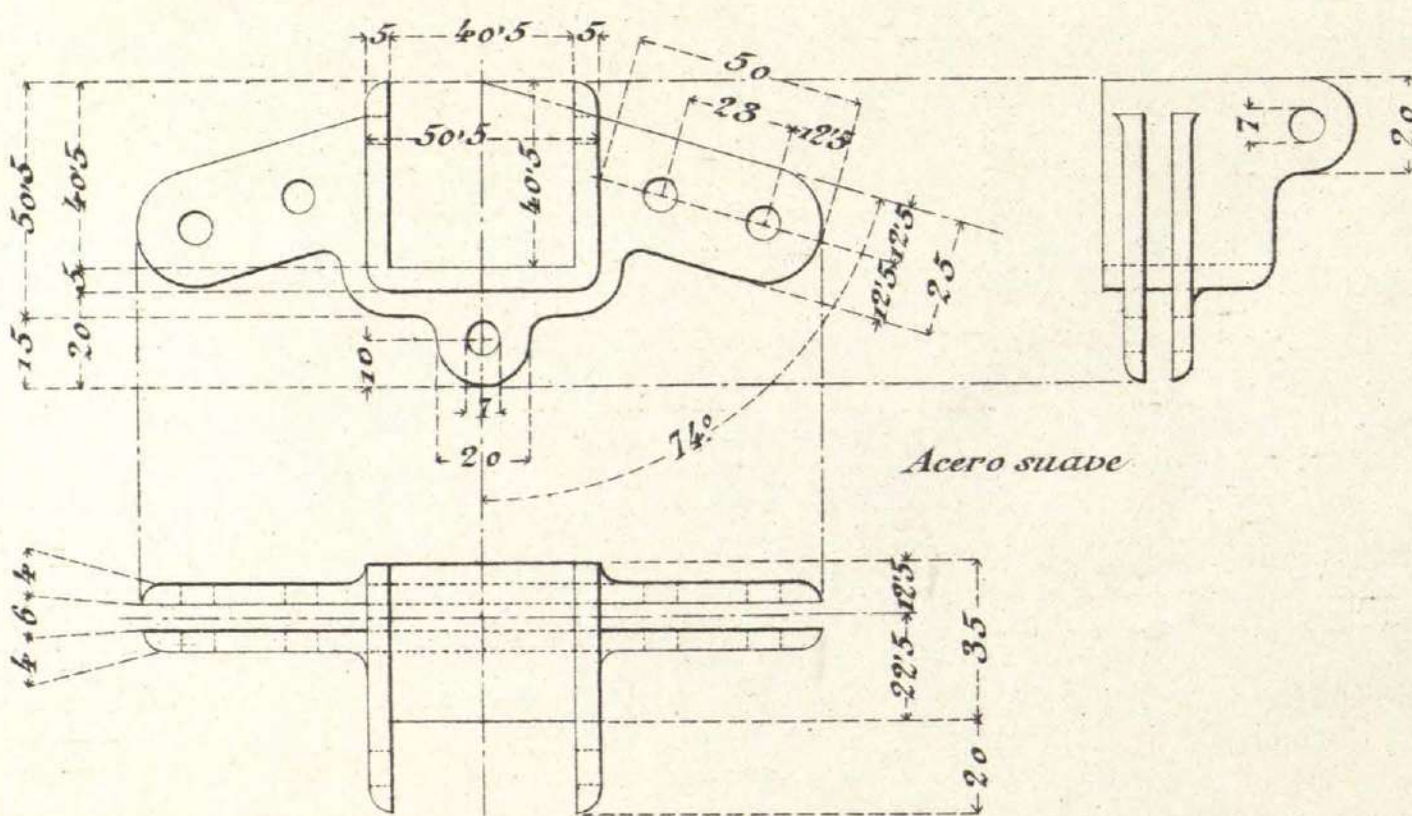

1 Ojal de la armadura posterior. (4/10)

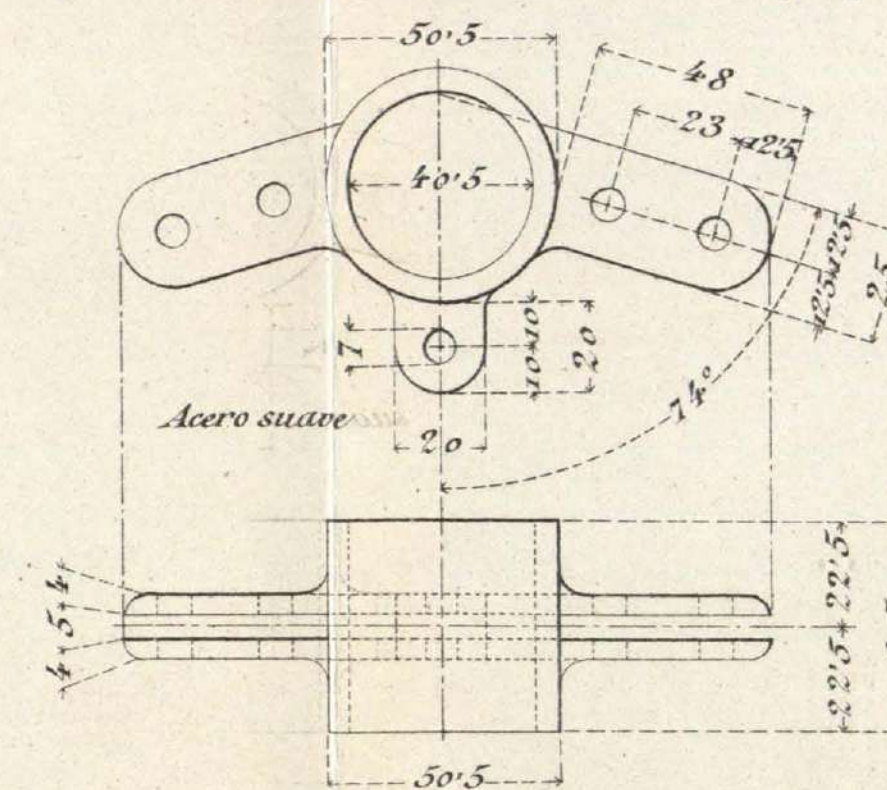

2 Pilarillos de las armaduras (4/10)

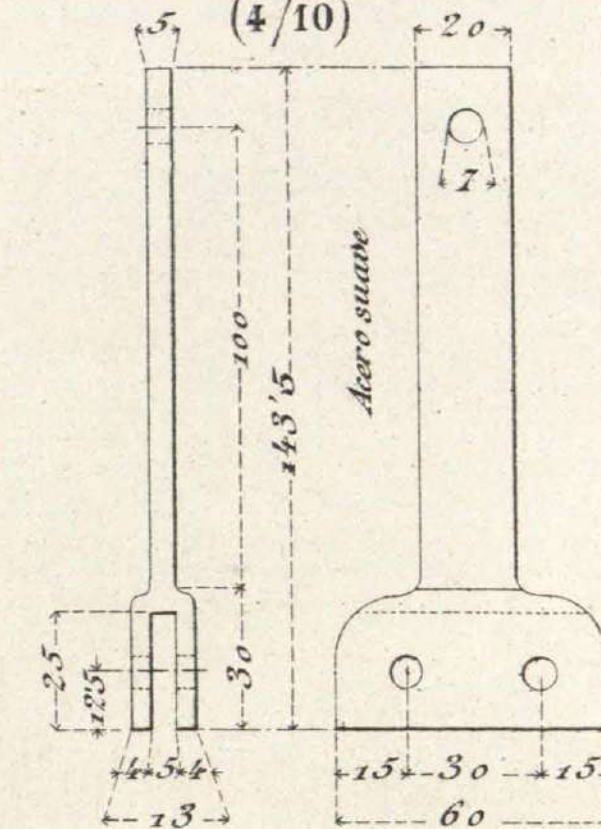

8 Placas de sujeción de las barras de cierre. (5/10)

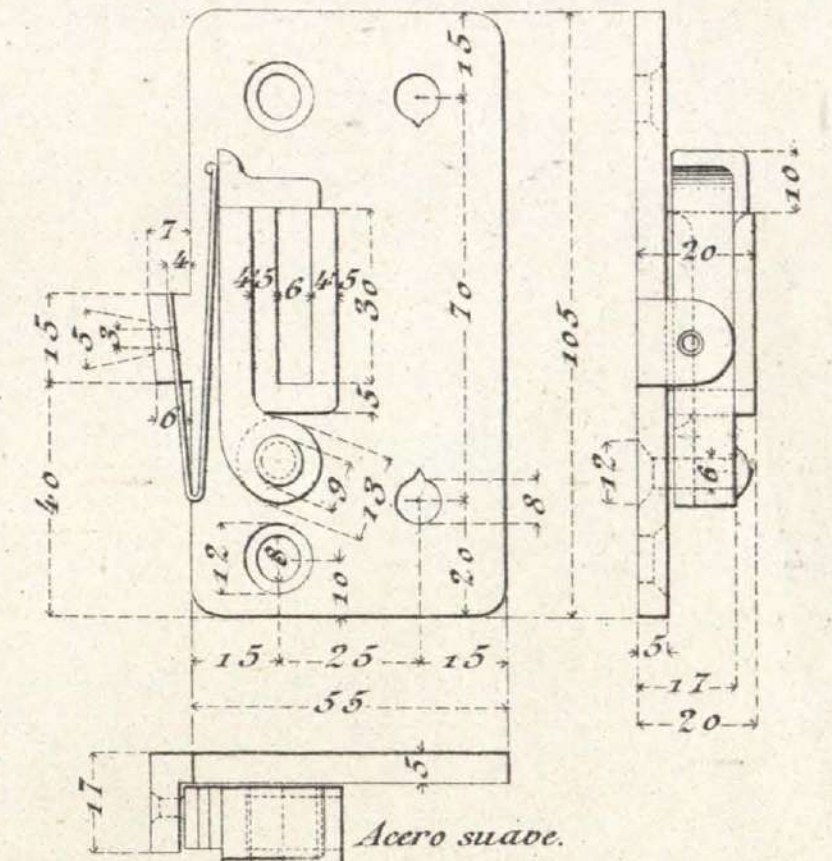

6 Asas de los tableros. (5/10)

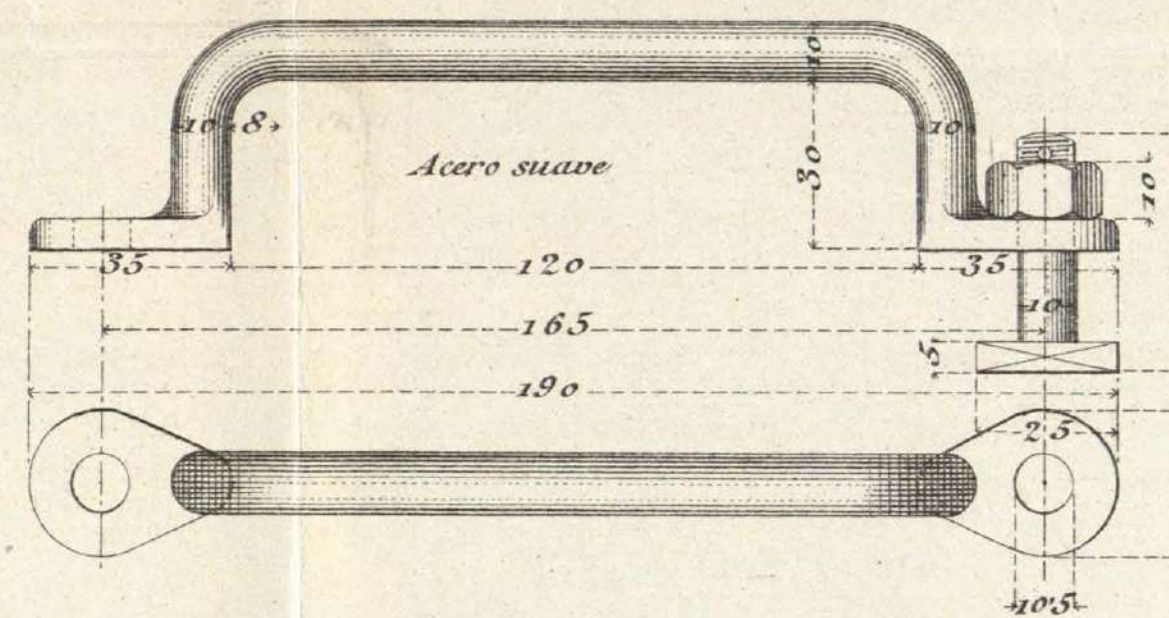

4 Pivotes de sujeción de las armaduras. (2 derecha y 2 izquierda)

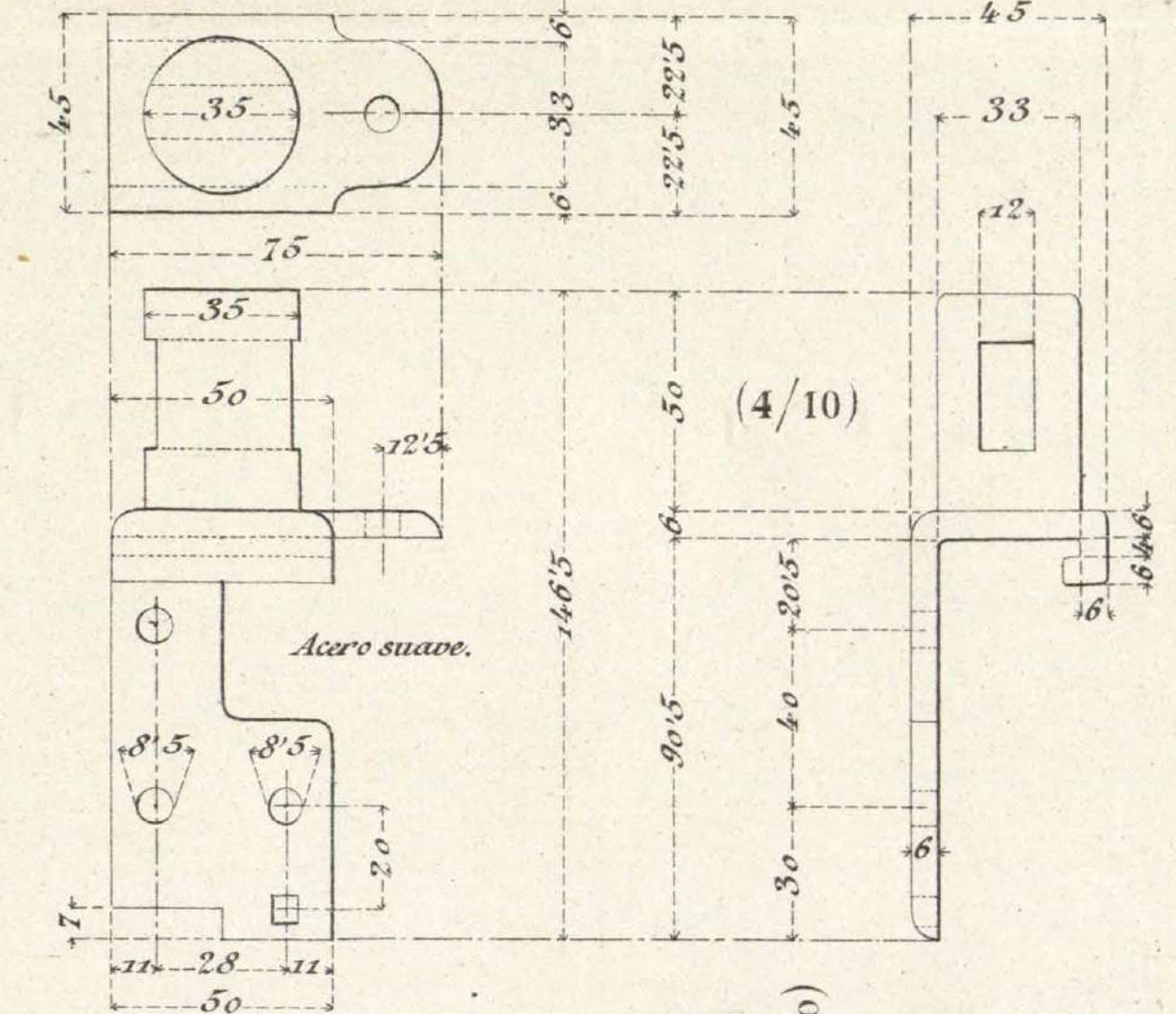

4 Chavetas. (4/10)

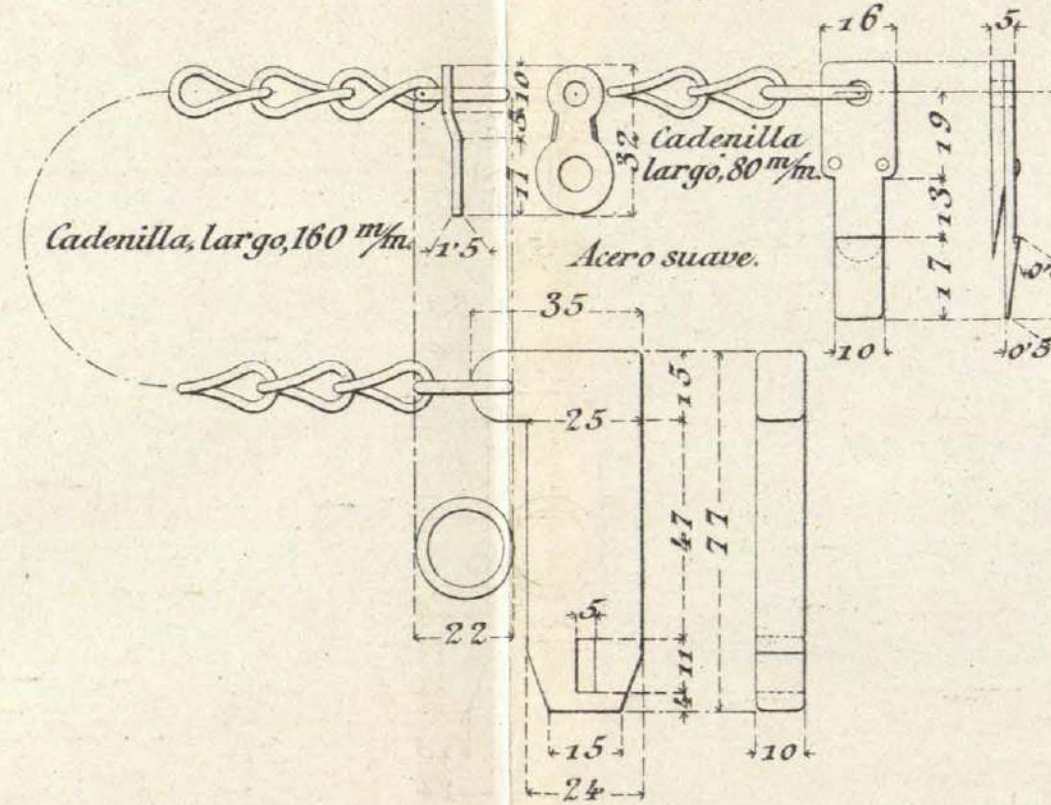

2 Bisagras de la armadura posterior. (5/10)

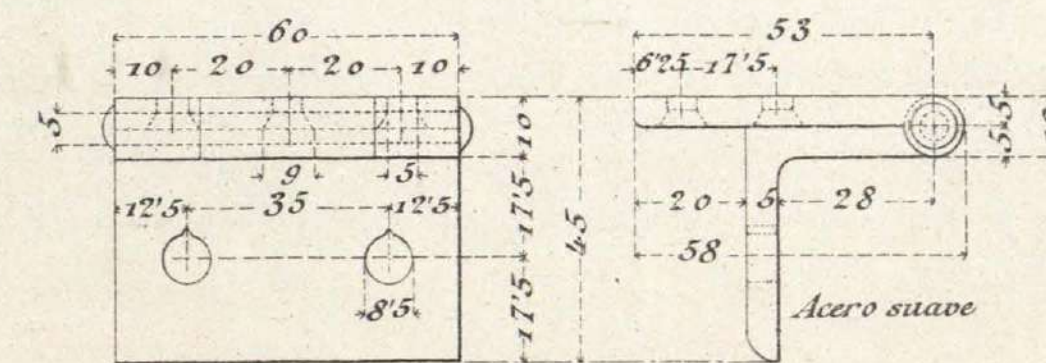

Pasador con cadenilla (4/10)

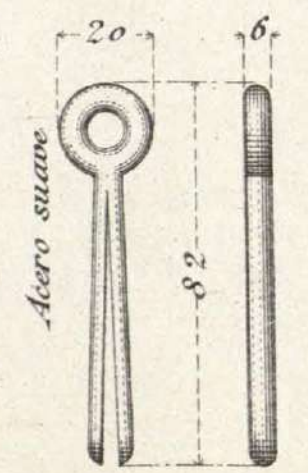

# CARRO DE BATERÍA NUMERO 1.

## DE TALLE S.

Cerrojo de la compuerta. (E=4/10.)

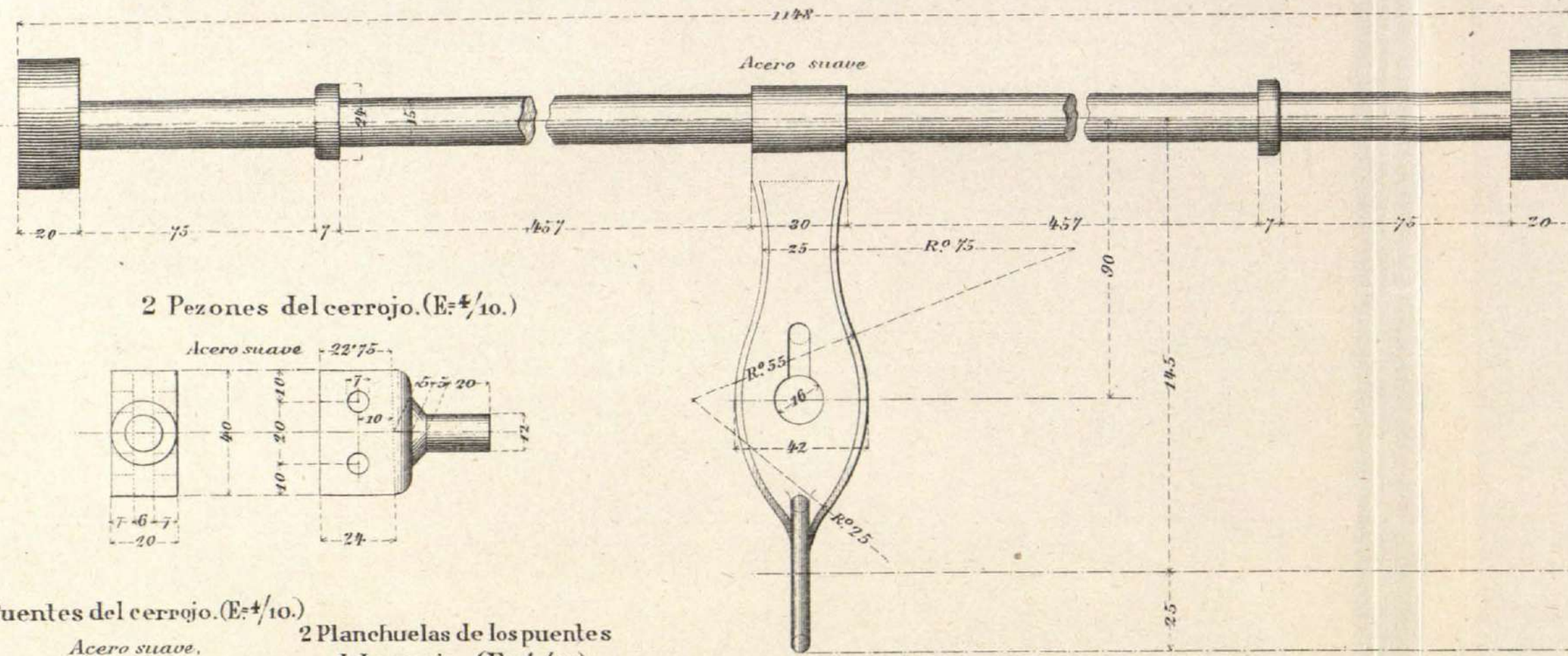

2 Pezones del cerrojo. (E=4/10.)

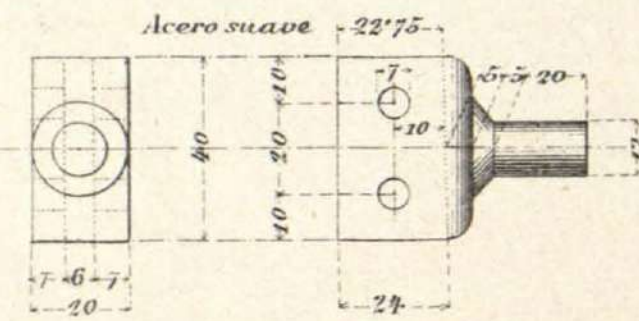

2 Puentes del cerrojo. (E=4/10.)

Acero suave.

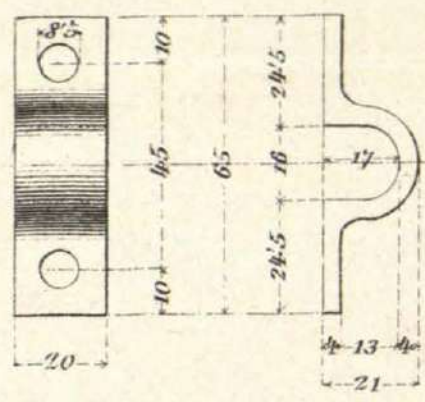

2 Planchuelas de los puentes del cerrojo. (E=4/10.)

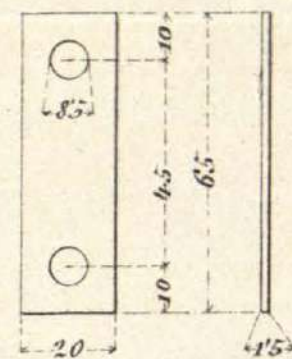

80 Remaches de las órapas del 2º y 3º lecho. (E=1/1.)

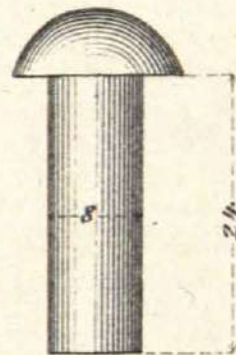

12 Remaches. (Pivotes del lecho) (E=1/1.)

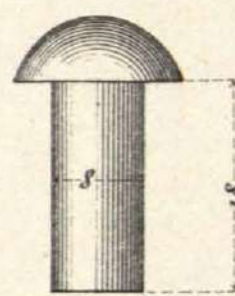

10 Tornillos de las escuadras de los pilarillos. (E=1/1.)

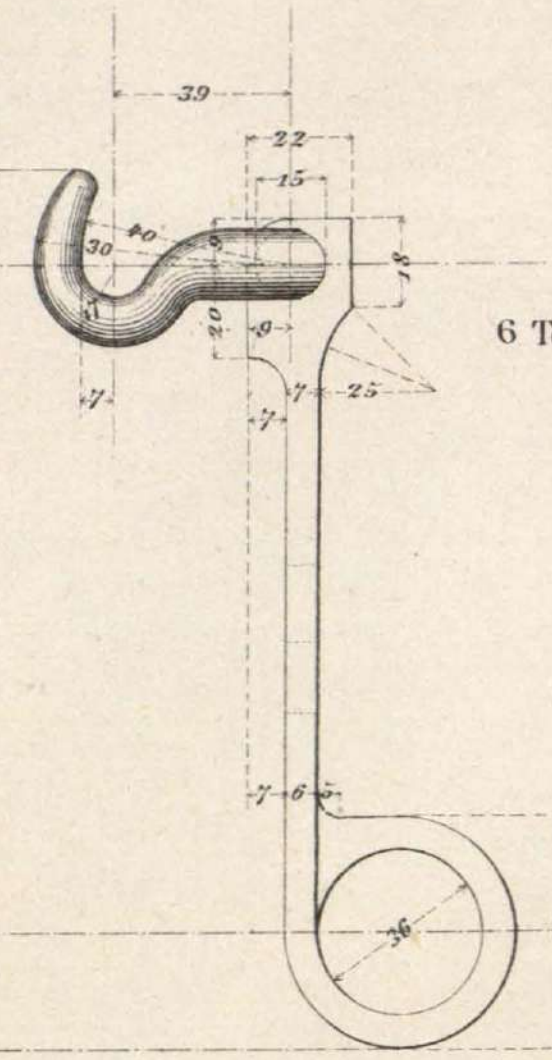
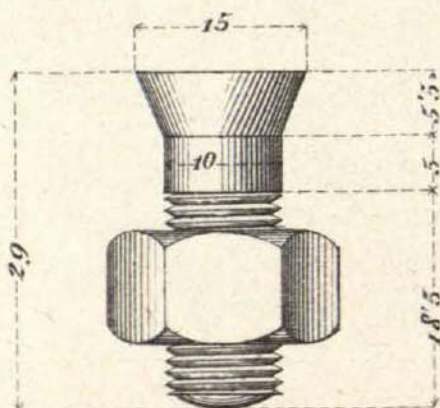

9 Tornillos para sujeción del tablero del 1º lecho. (E=1/1.)

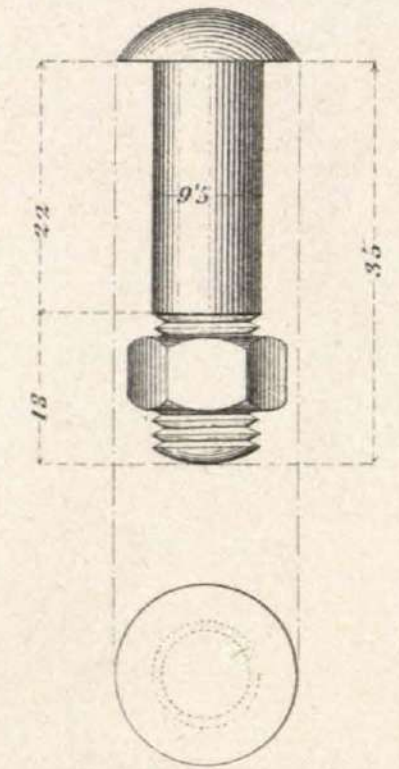

6 Tornillos de las bisagras. (E=1/1.)

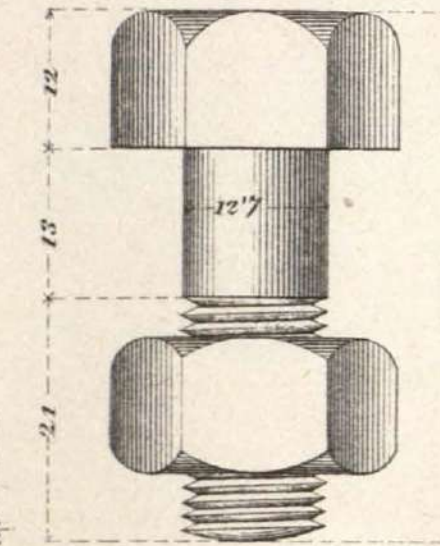

Bisagras de la compuerta. (E=3/10.)

Acero suave

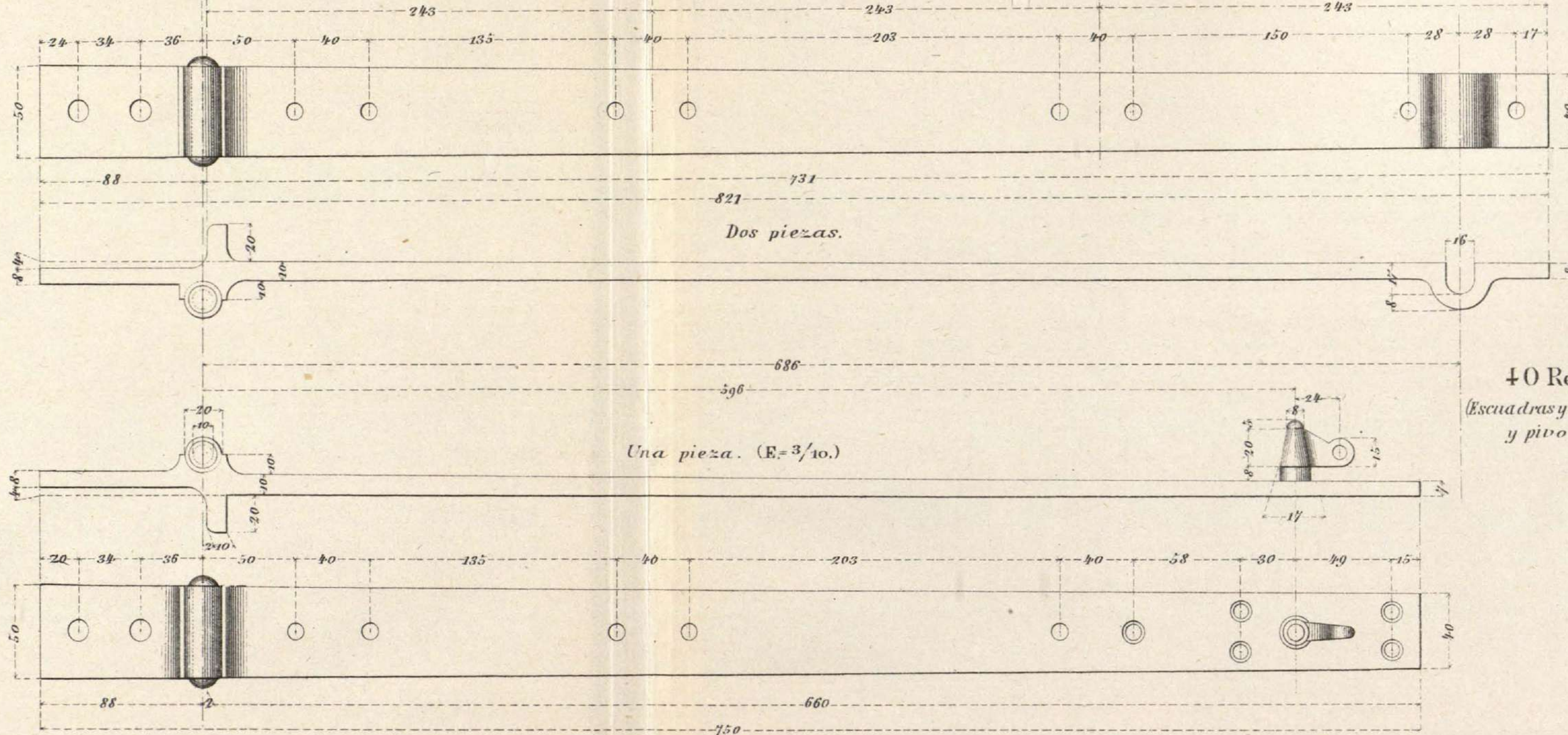

4 Remaches. (E=1/1.) (Pezones del cerrojo.)

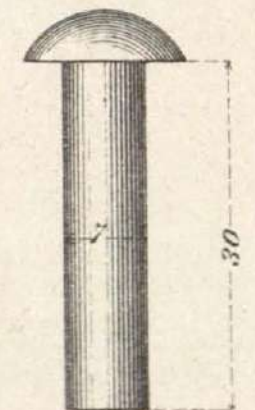

40 Remaches. (E=1/1.) (Escuadras y angulares de pilarillos y pivotes del lecho.)

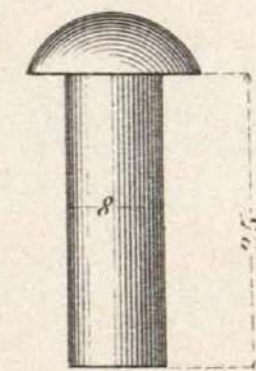



# CARRO DE BATERÍA NÚMERO 1.

## DETALLES.

4 Solrozos. (E=1/2.)  
Acero suave

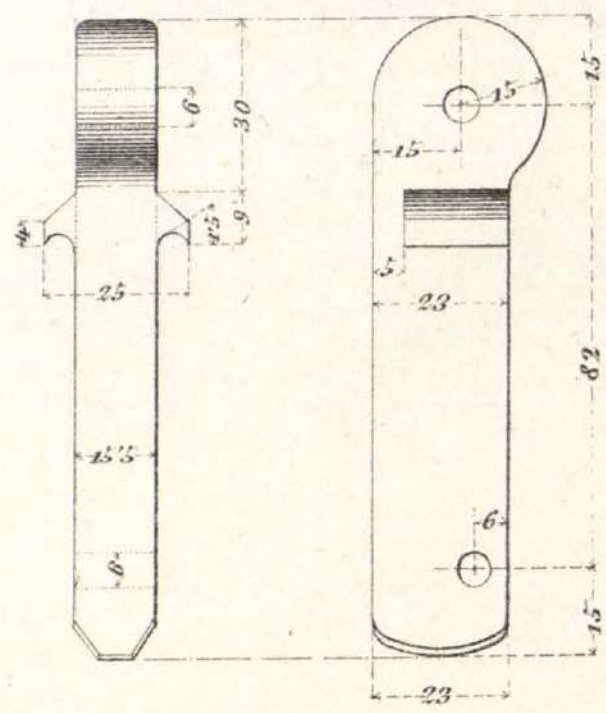

4 Volanderas interiores. (E=1/2.)  
Acero suave

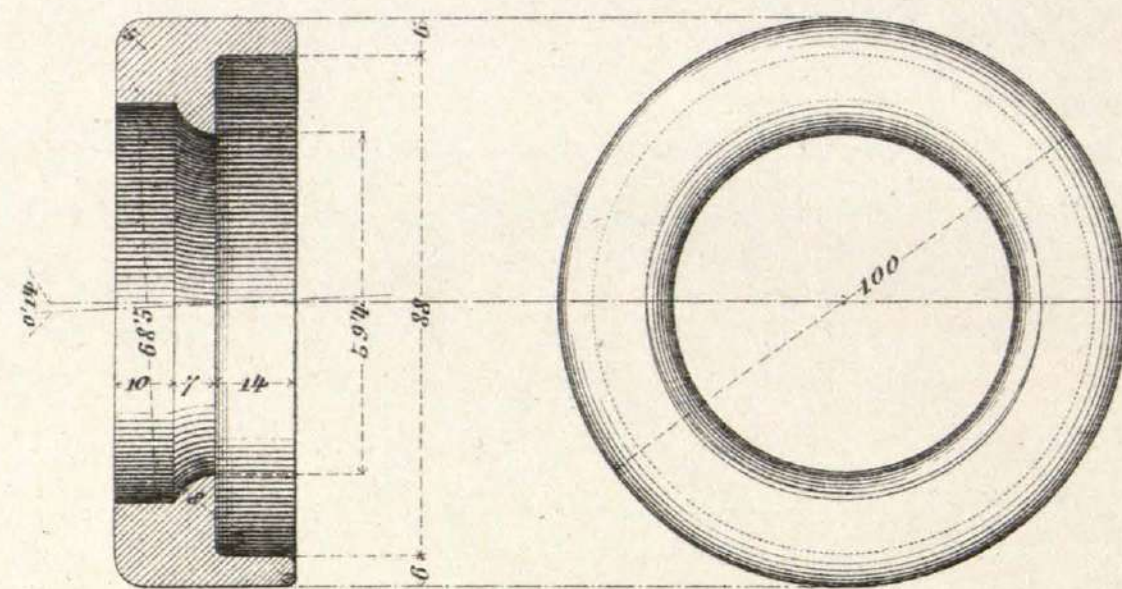

4 Volanderas exteriores. (E=1/2.)  
Acero suave

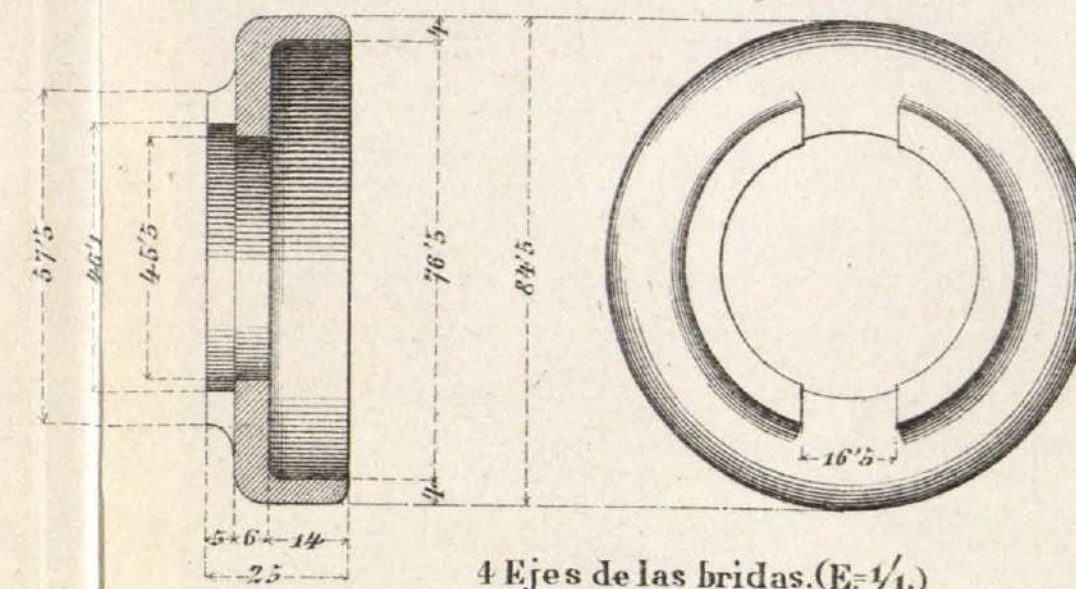

4 Bridas de los solrozos. (E=1/2.)  
Acero suave.

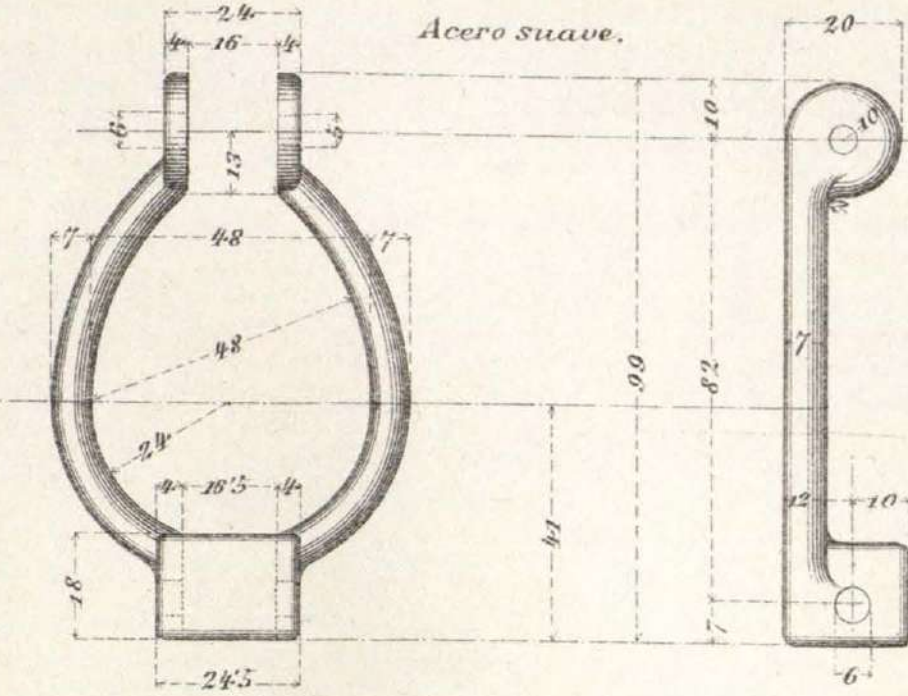

Eje del carro. (E=1/10.)  
Acero

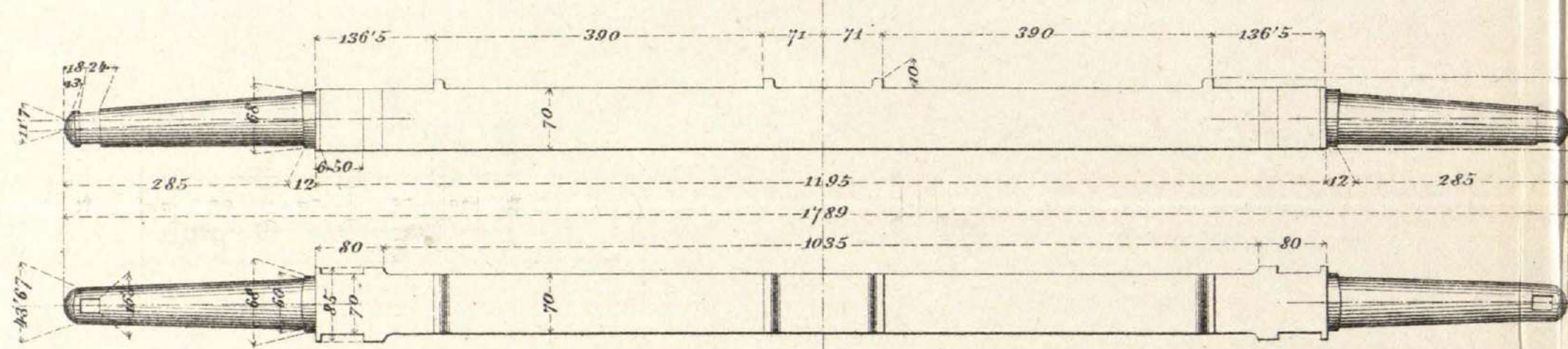

4 Ejes de las bridas. (E=1/4.)  
Acero suave

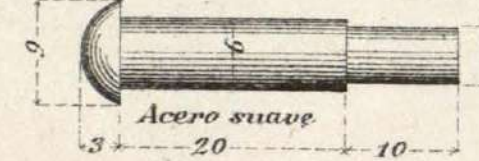

2 Braças del eje del retrotren. (E=1/5.)  
Acero suave.

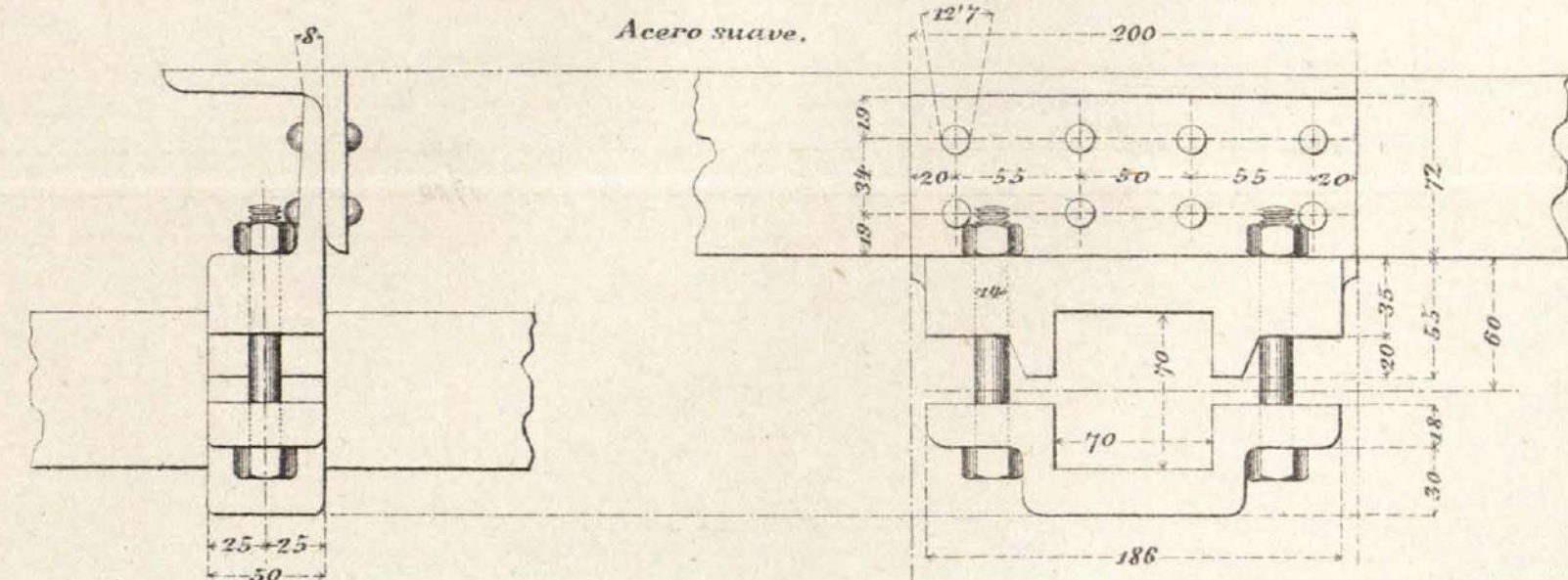

Eje del avantren. (E=1/10.)  
Acero

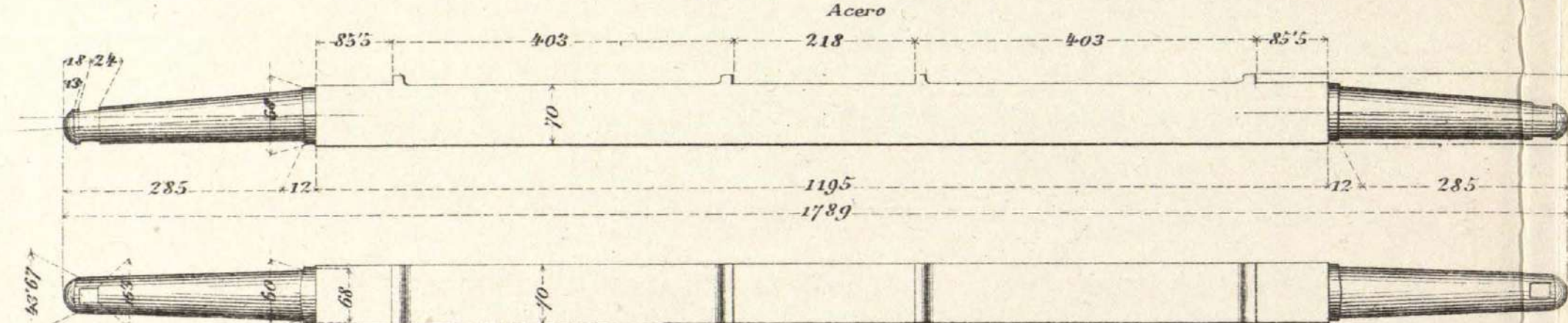

Cadena del pasador. (E=3/10.)  
11 eslabones. (Hierro forjado.)

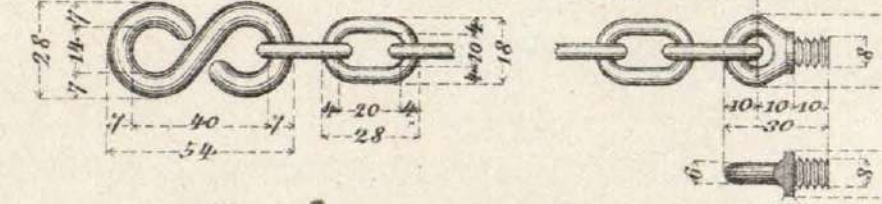

Pasador de sujeción de la lanza. (E=1/2.)  
Acero suave

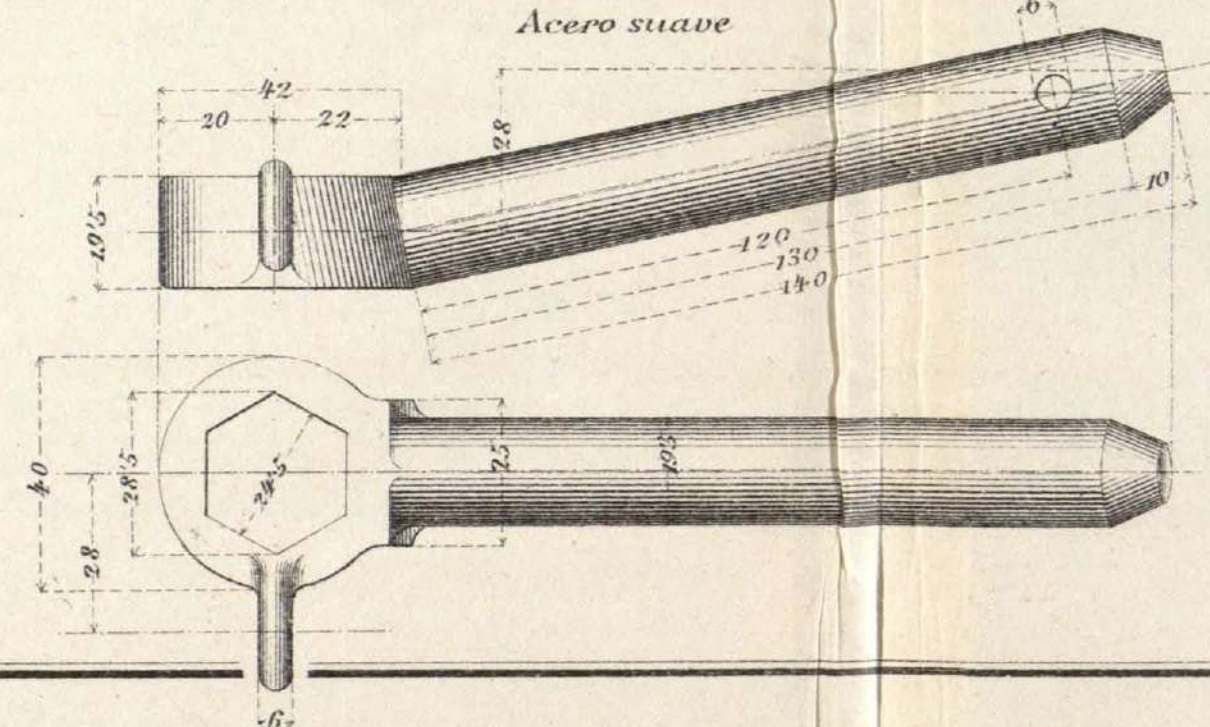

Chaveta del pasador con cadenilla. (E=1/2.)  
Acero suave.

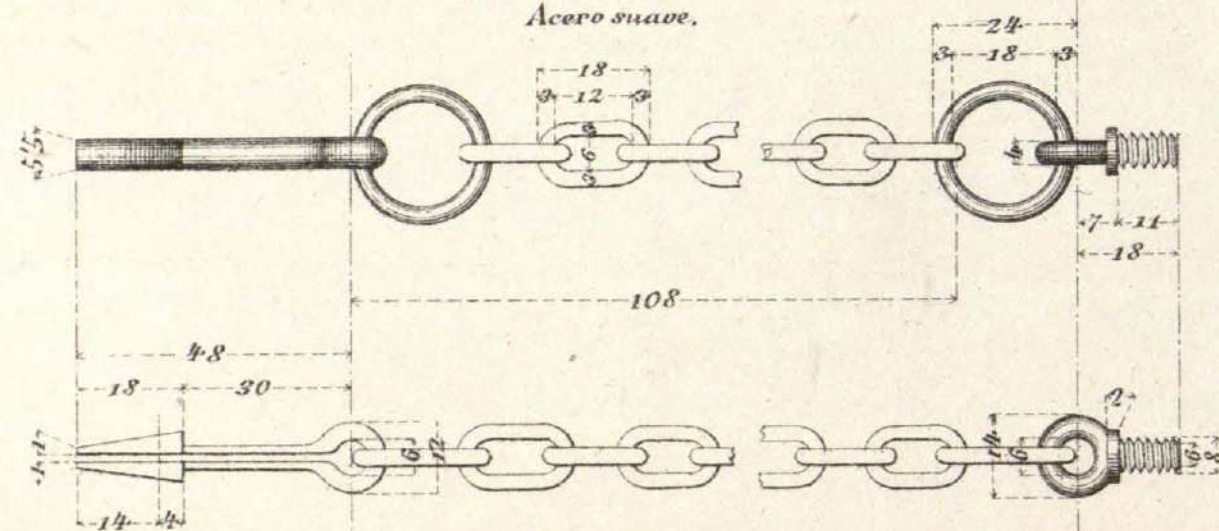

(6 Braças de eje. (2 para el retrotren y 4 para el avantren. (E=1/5.)  
Acero suave.

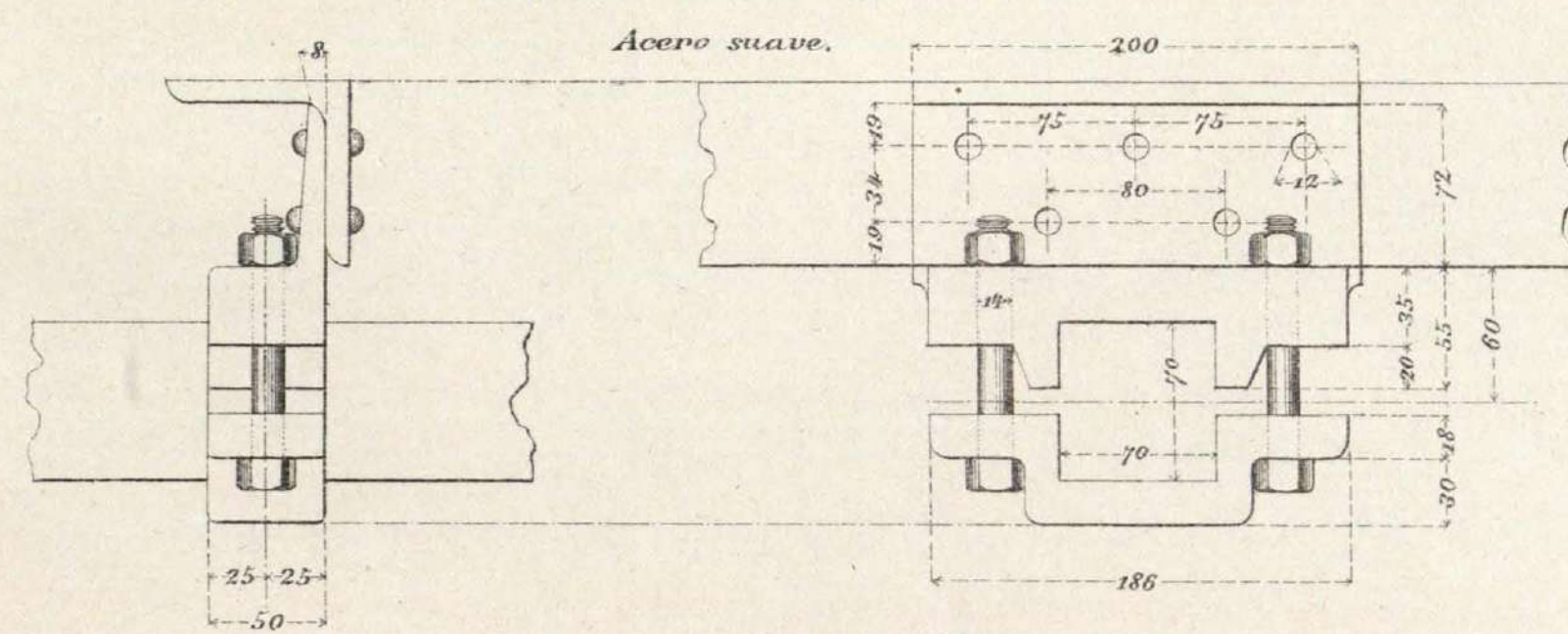





# CARRO DE BATERÍA NÚMERO 1.

## DETAJES.

2 Vástagos de los enganches. (E.-1/2.)  
Acero suave.

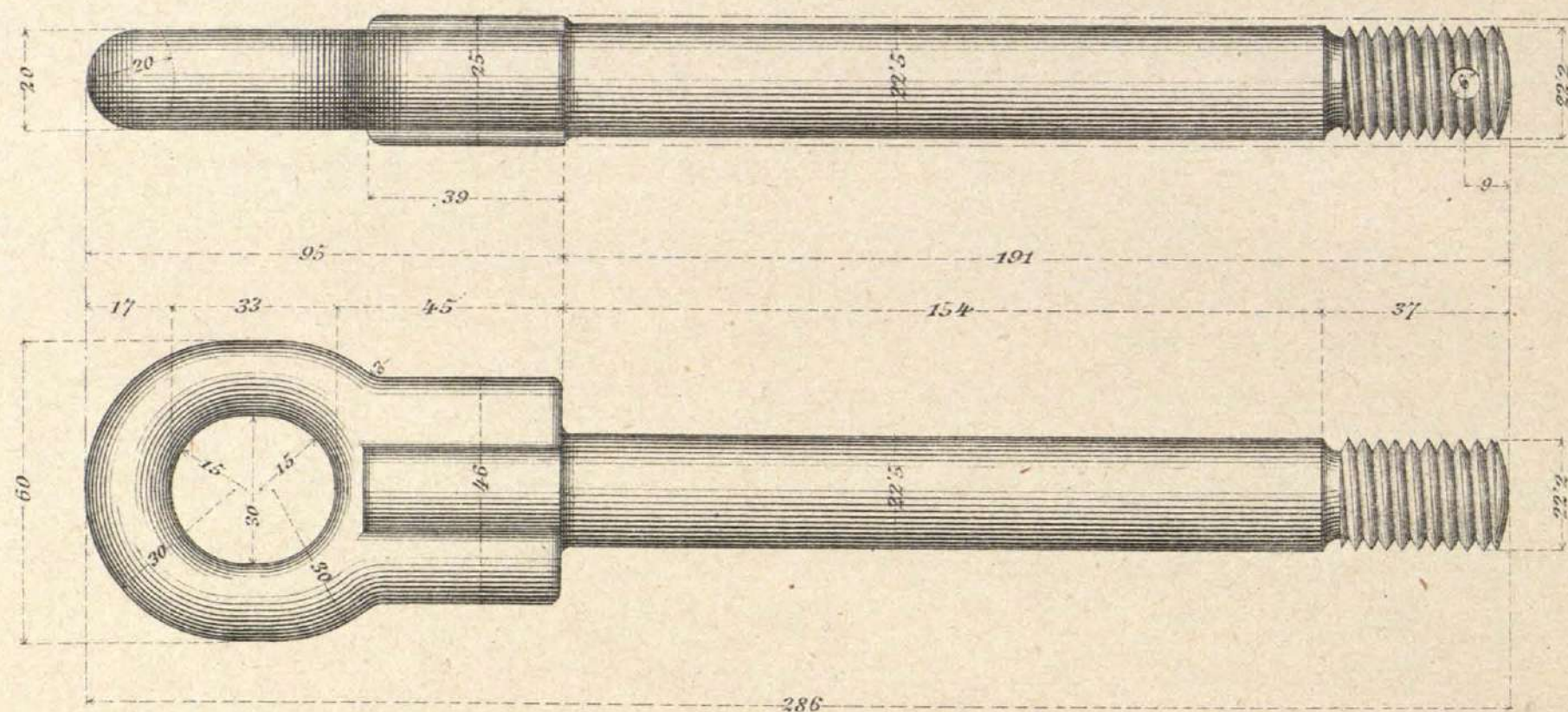

2 Muelles. (E.-1/2.)  
Acero especial.

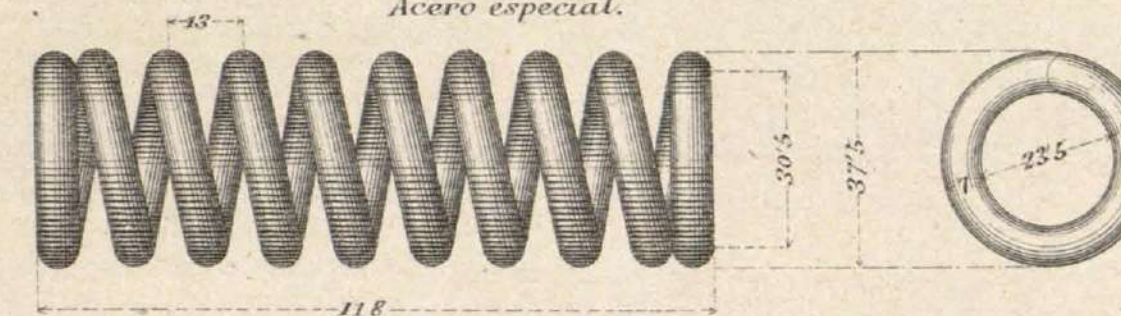

2 Planchuelas de las guías del freno. (E.-1/2.)  
Acero suave.

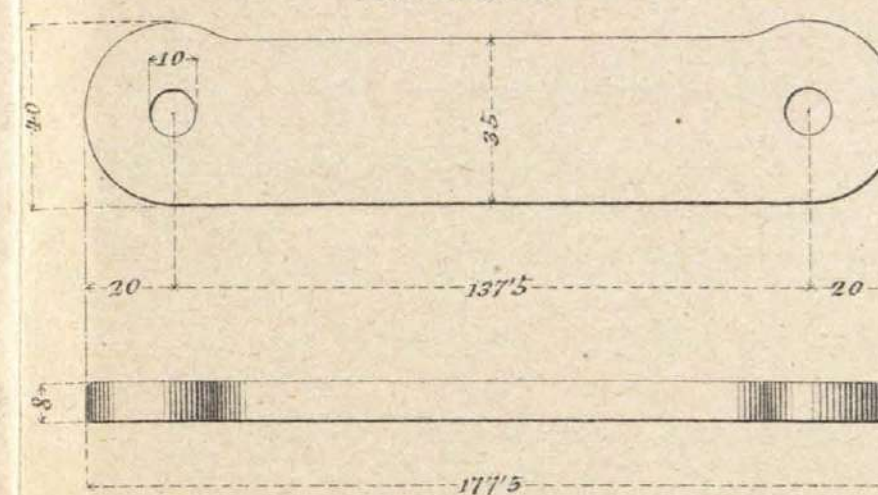

Soportes de los enganches elásticos. (E.-1/2.)  
2 Piezas. (derecha e izquierda.)

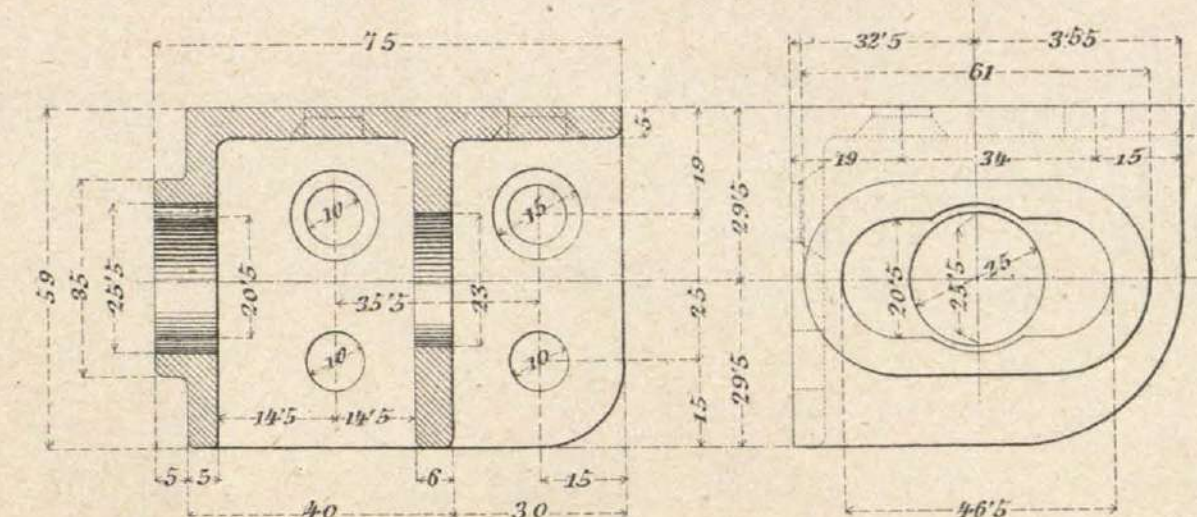

2 Tuercas de los vástagos de los enganches. (E.1/2.)  
Acero suave

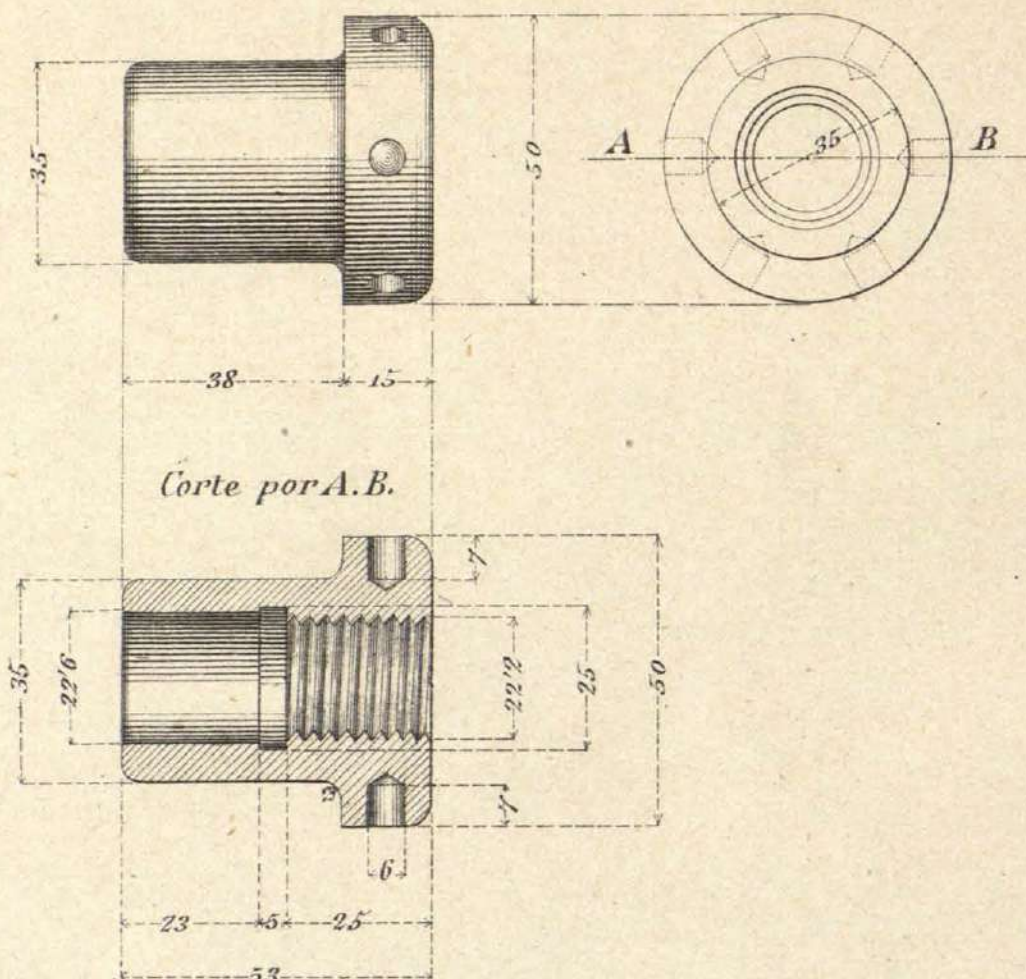

2 Eses para enganches de los balancines. (E.-1/2.)

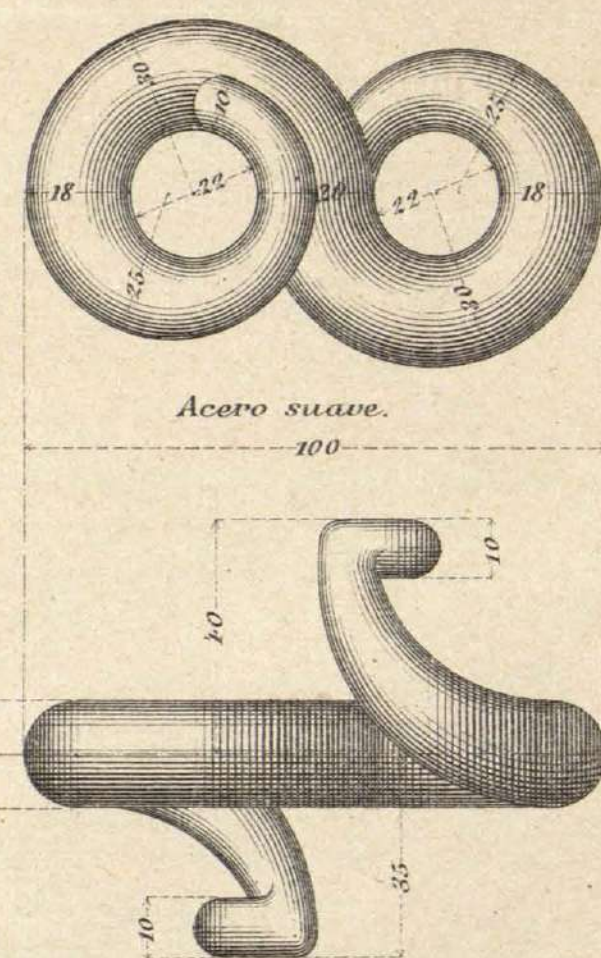

2 Volanderas de presión. (E.-1/2.)  
Acero suave

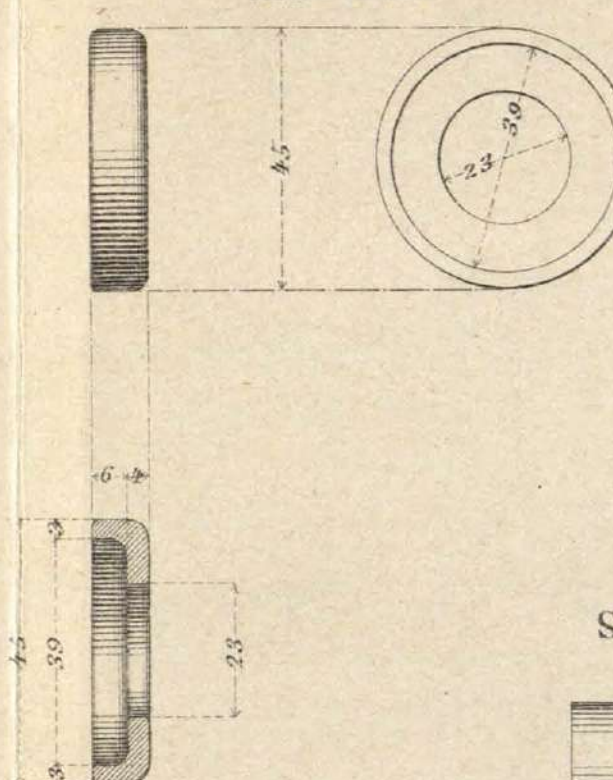

2 Piezas. (E.-1/2.)

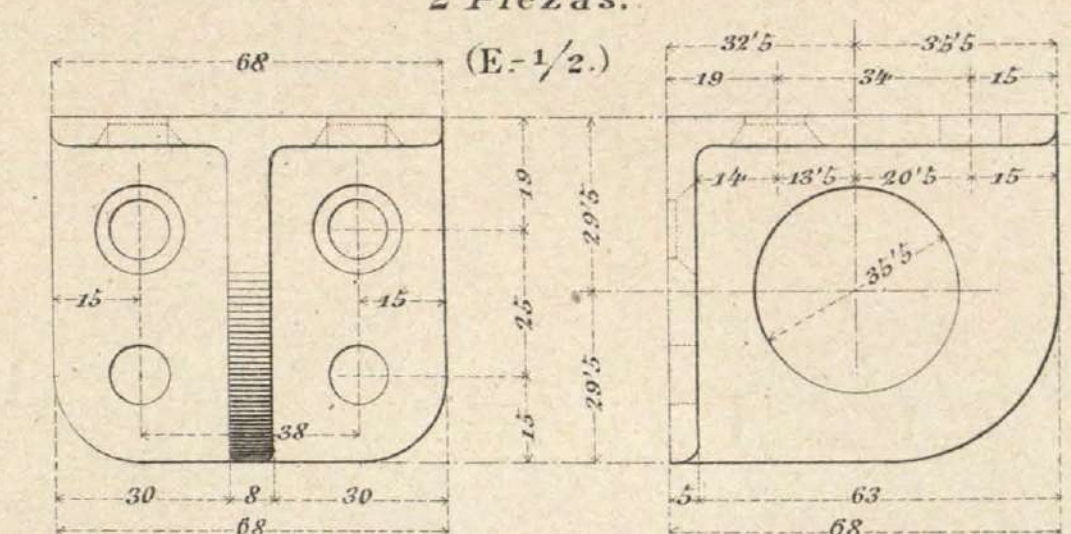

Suplemento del eje del freno. (E.-4/10.)  
Acero suave

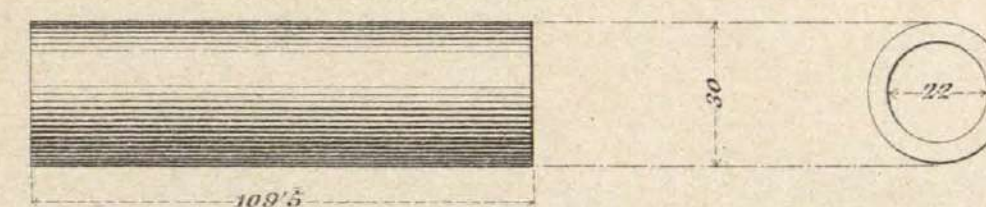

Eje del freno. (E.-4/10.)  
Acero suave.

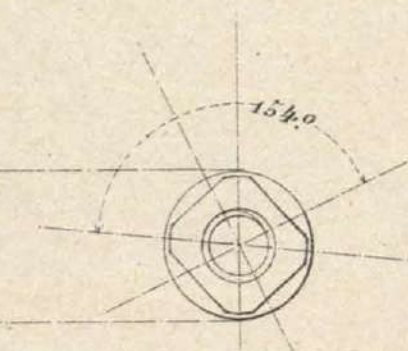
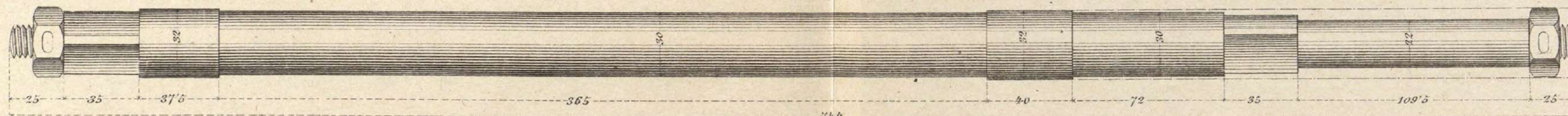





# CARRO DE BATERÍA NÚMERO 1.

Caja de retrotren. (2/10.)

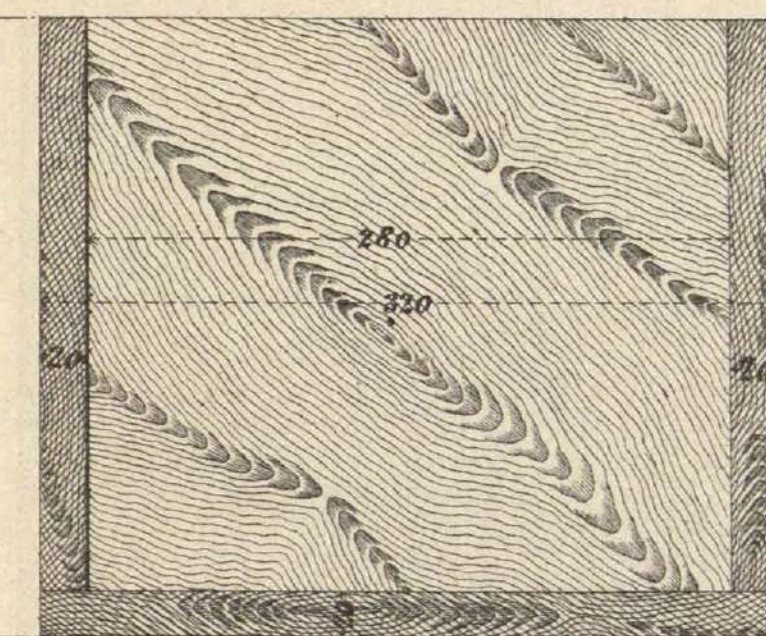
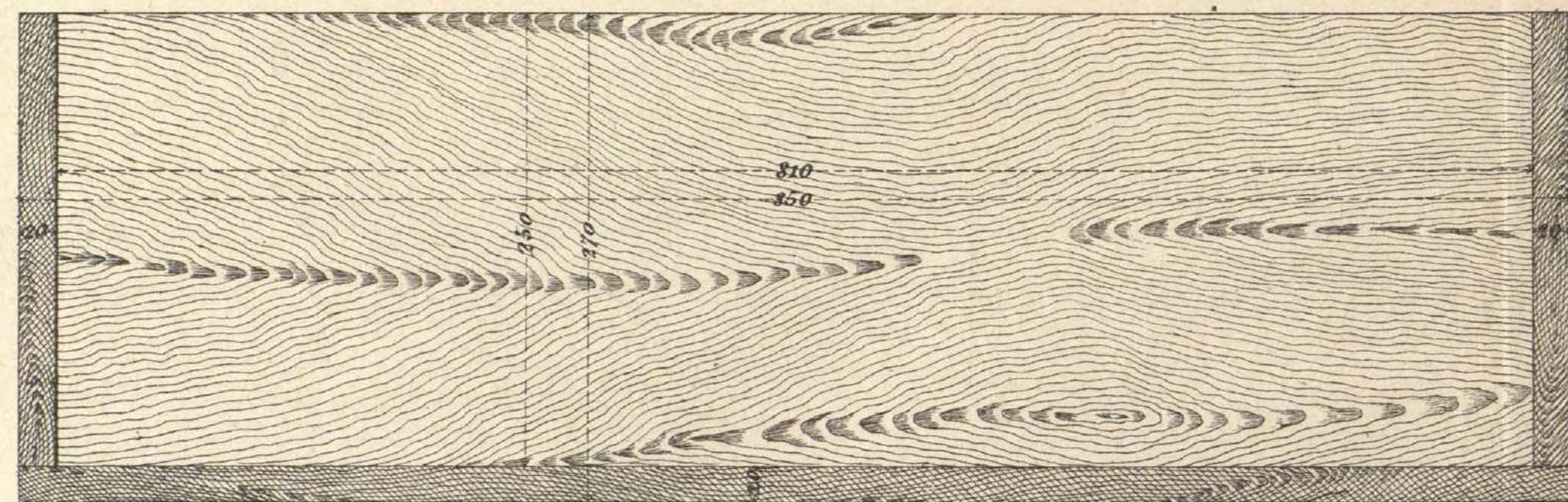
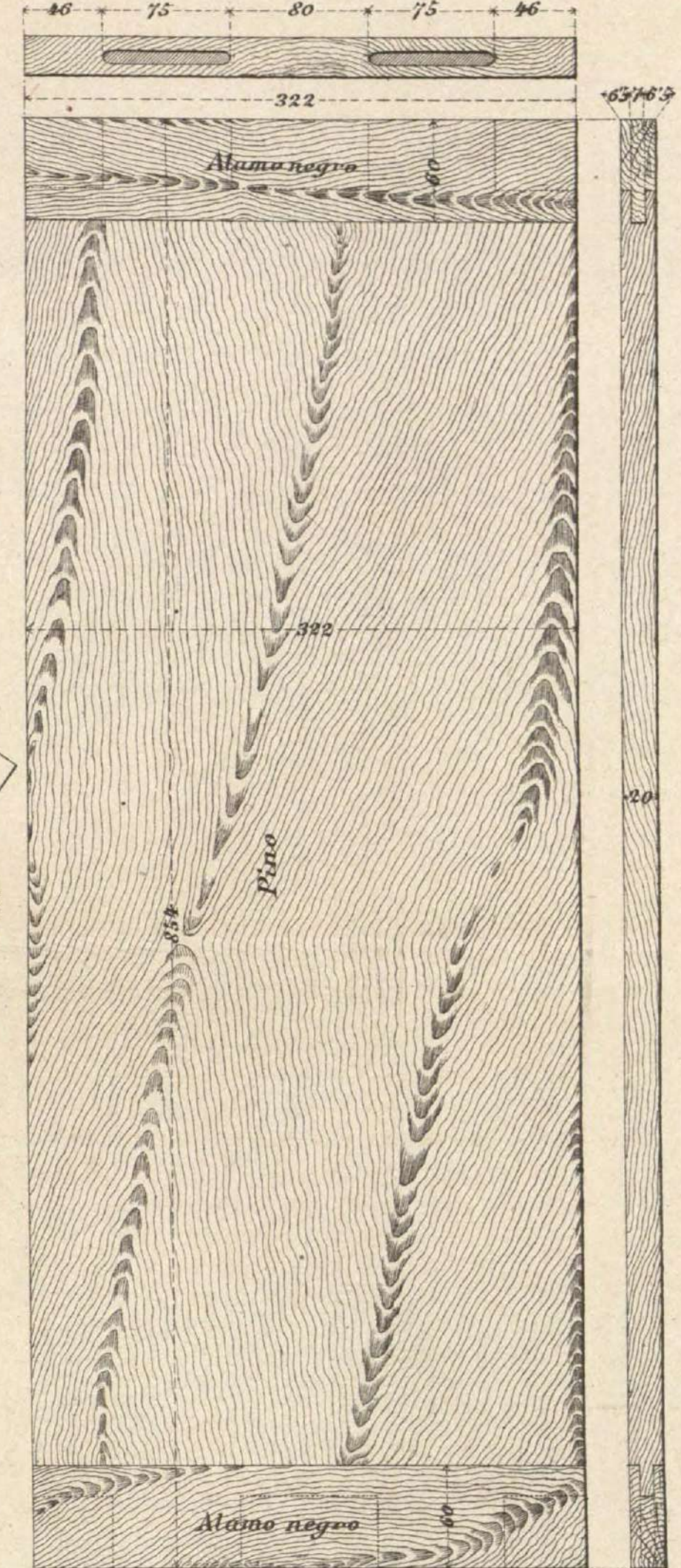
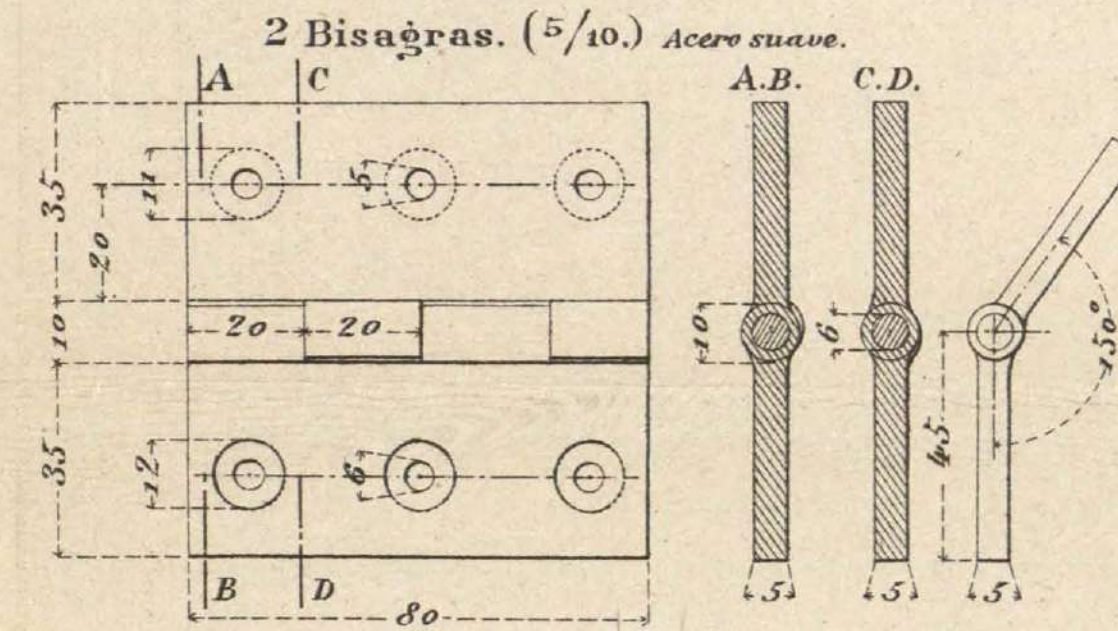
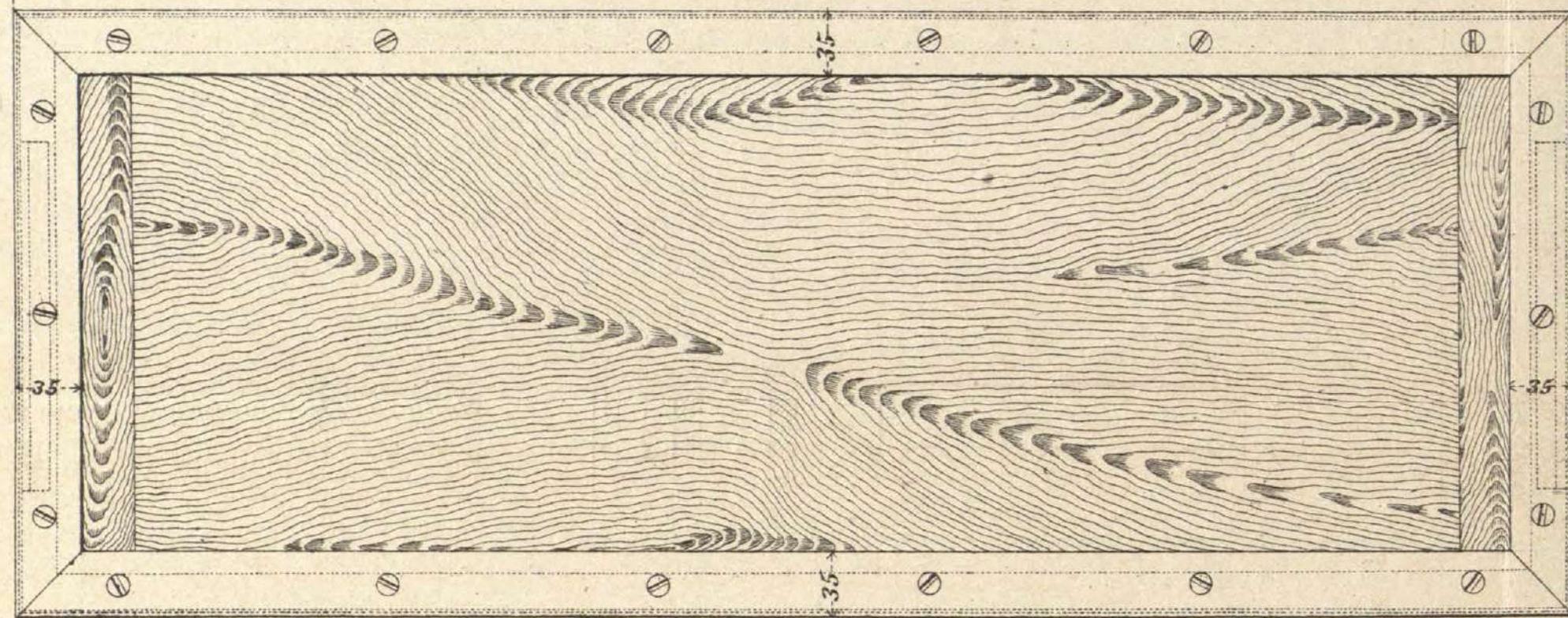
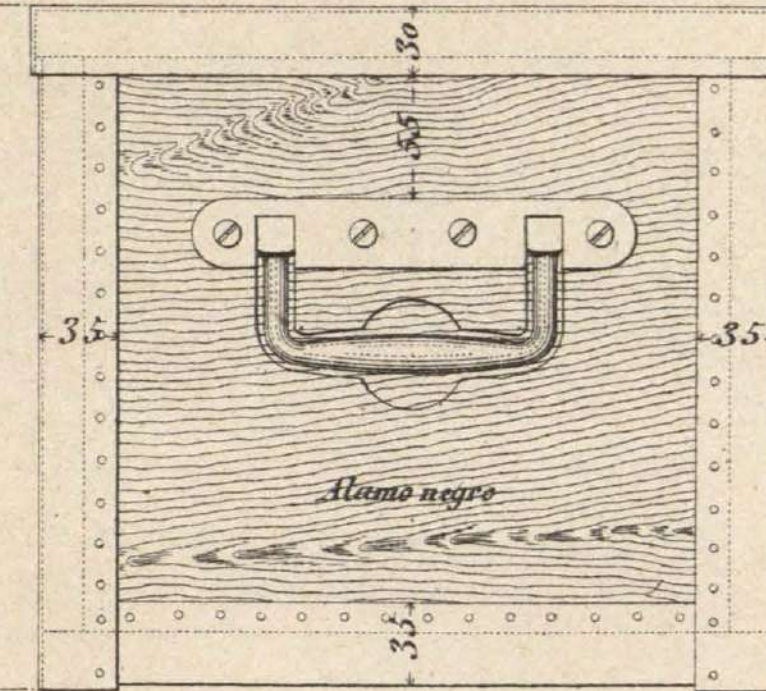
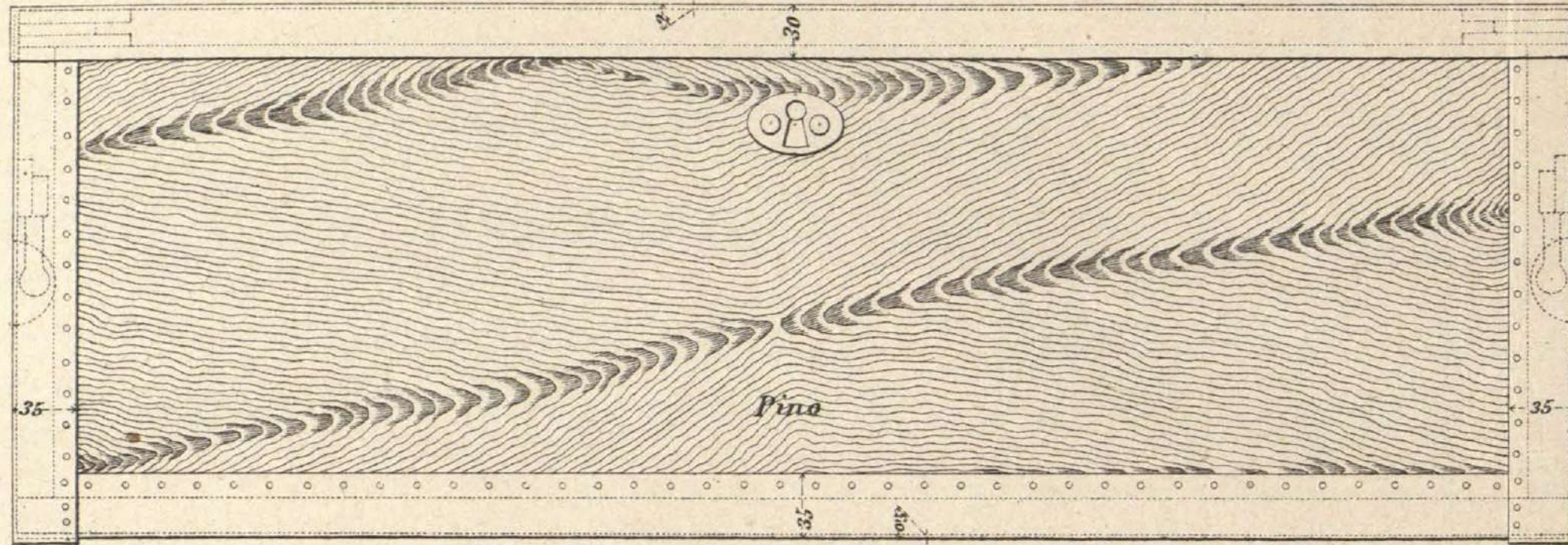

6 Remaches para sujetar las bisagras al cuerpo de la caja. (1/1.)

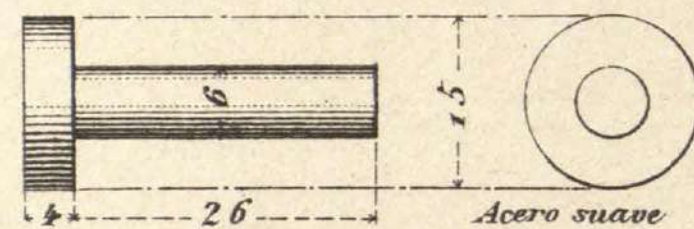

6 Tornillos de rosca para madera. (1/1.)

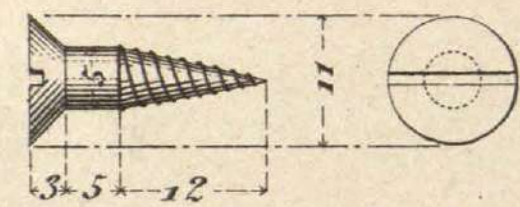

Cantonera. (5/10.)



Recercado. (5/10.)

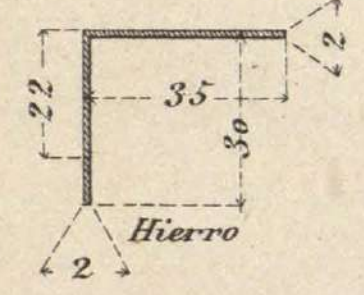

2 Asas (5/10.)

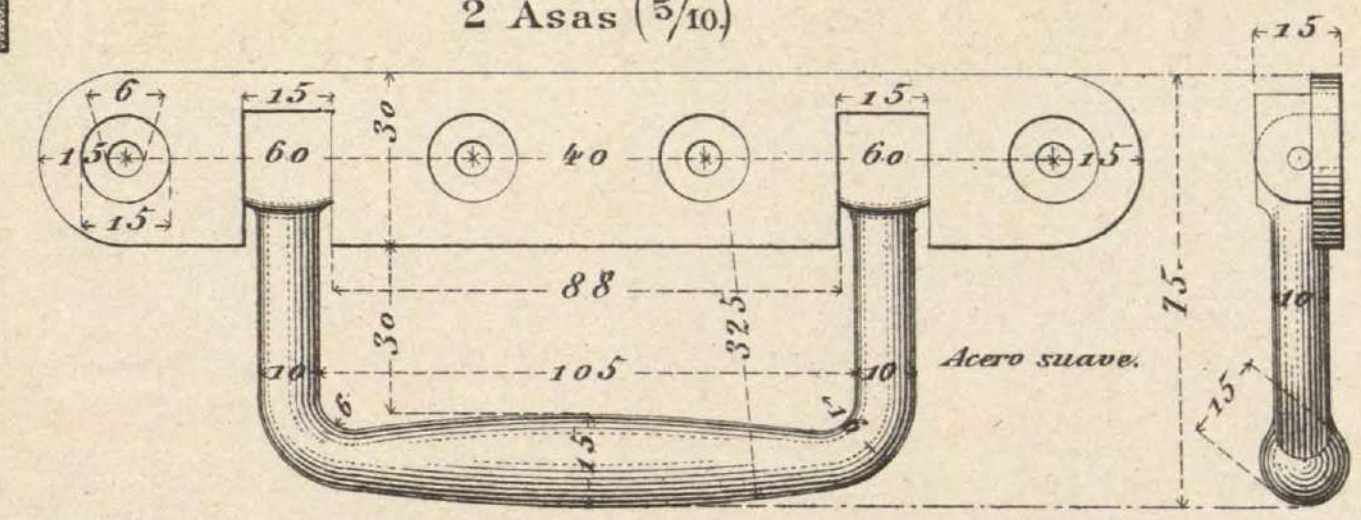

# CARRO DE BATERÍA NÚMERO 1.

Caja de equipaje del Capitán.

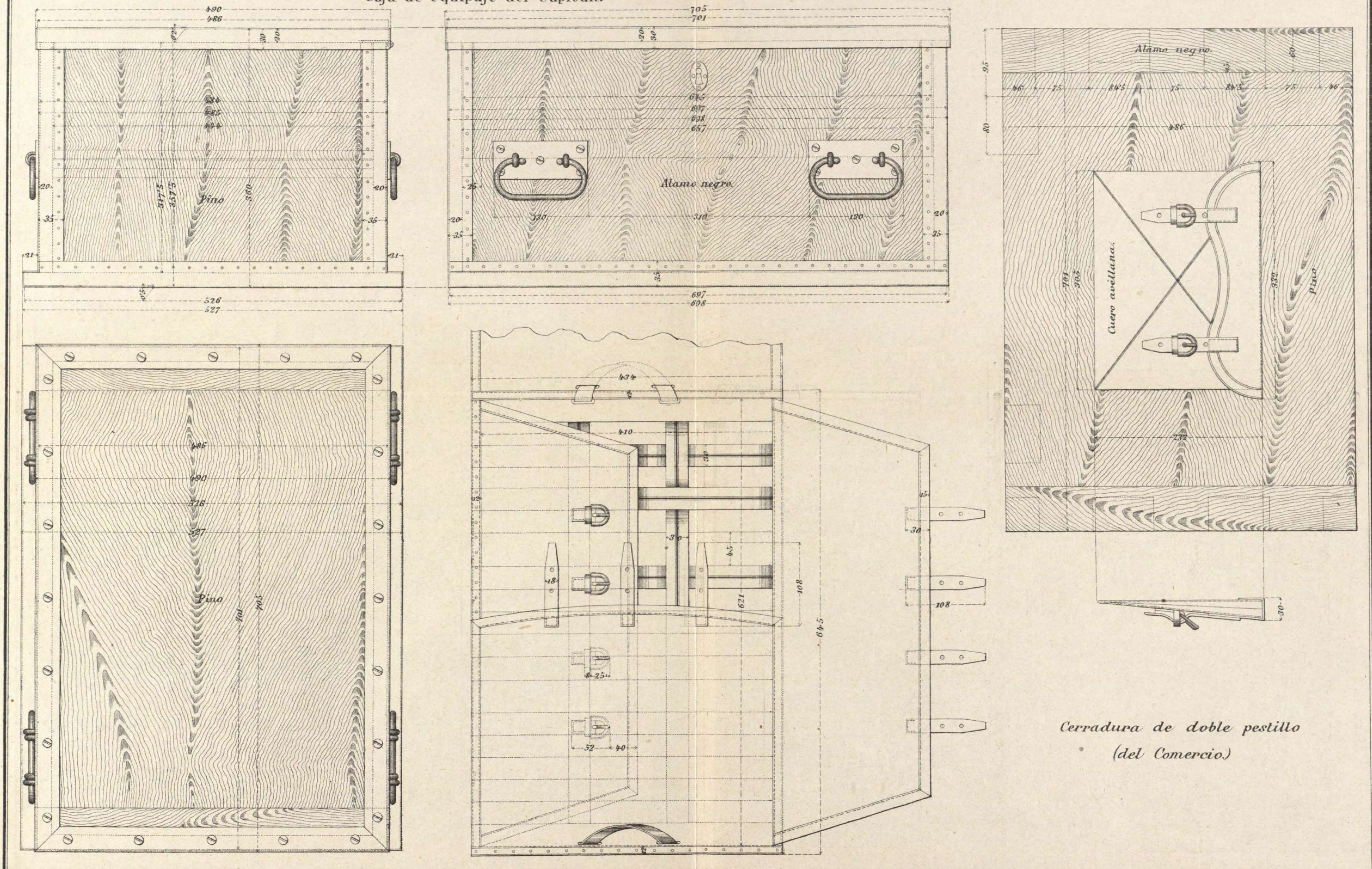

Cerradura de doble pestillo  
(del Comercio.)



# CARRO DE BATERÍA NÚMERO 1.

## CAJA PARA DOCUMENTACIÓN

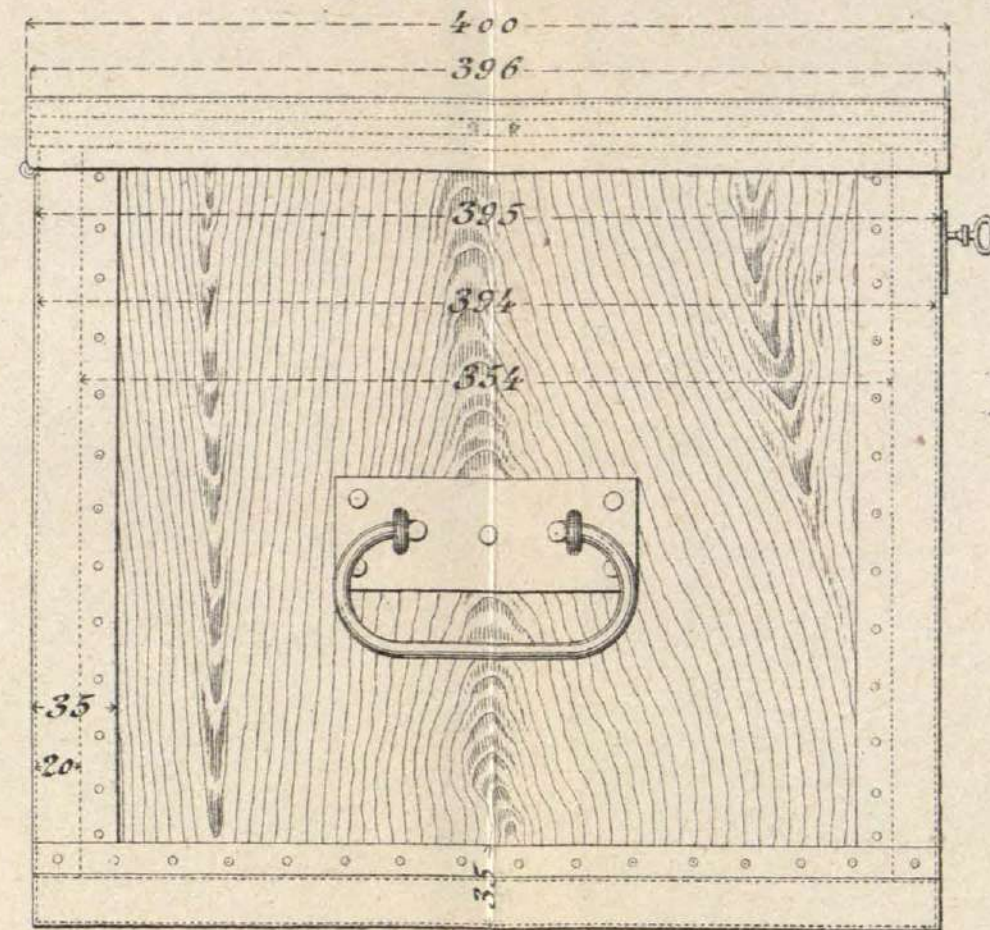
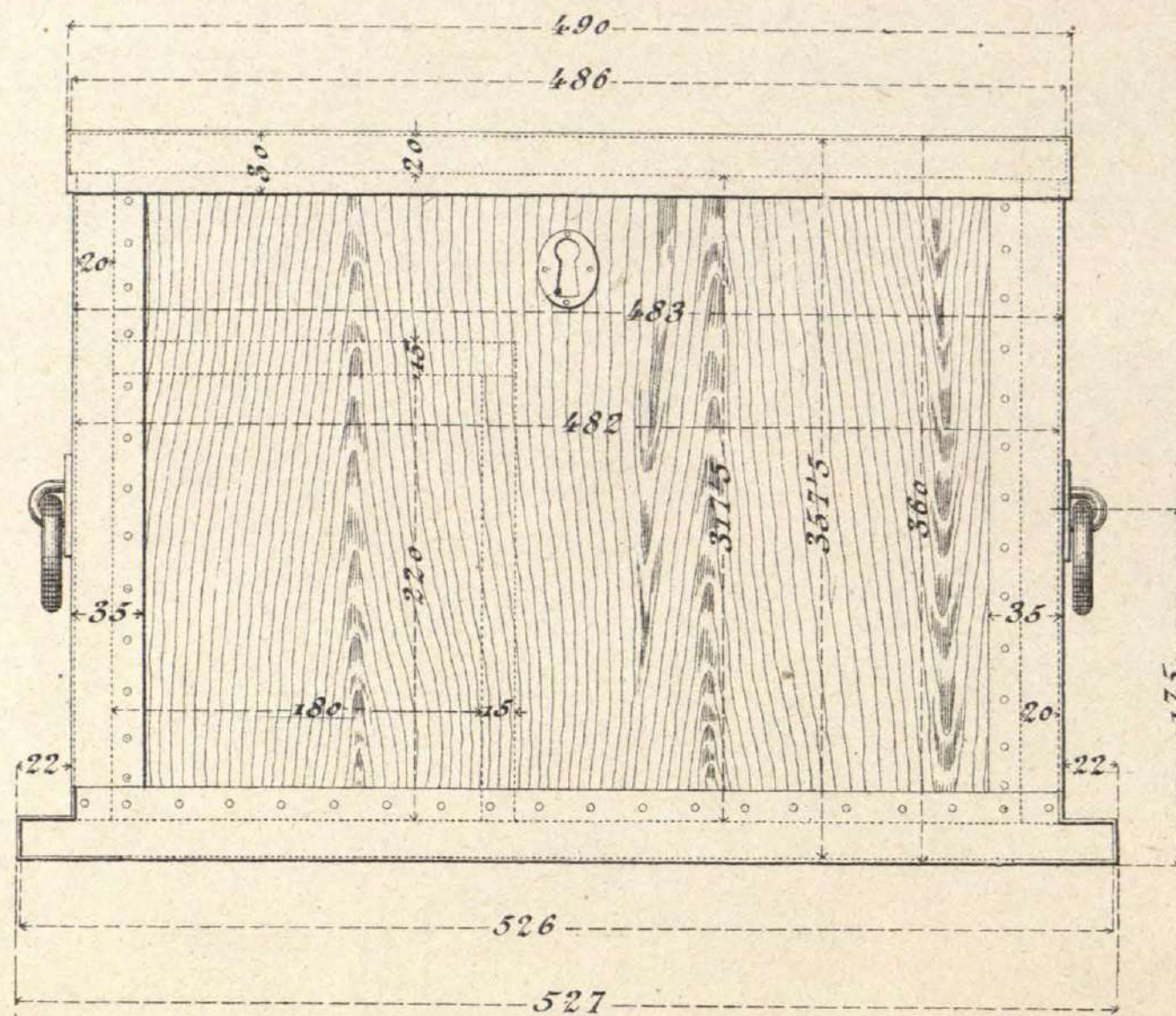

Escala 1/5

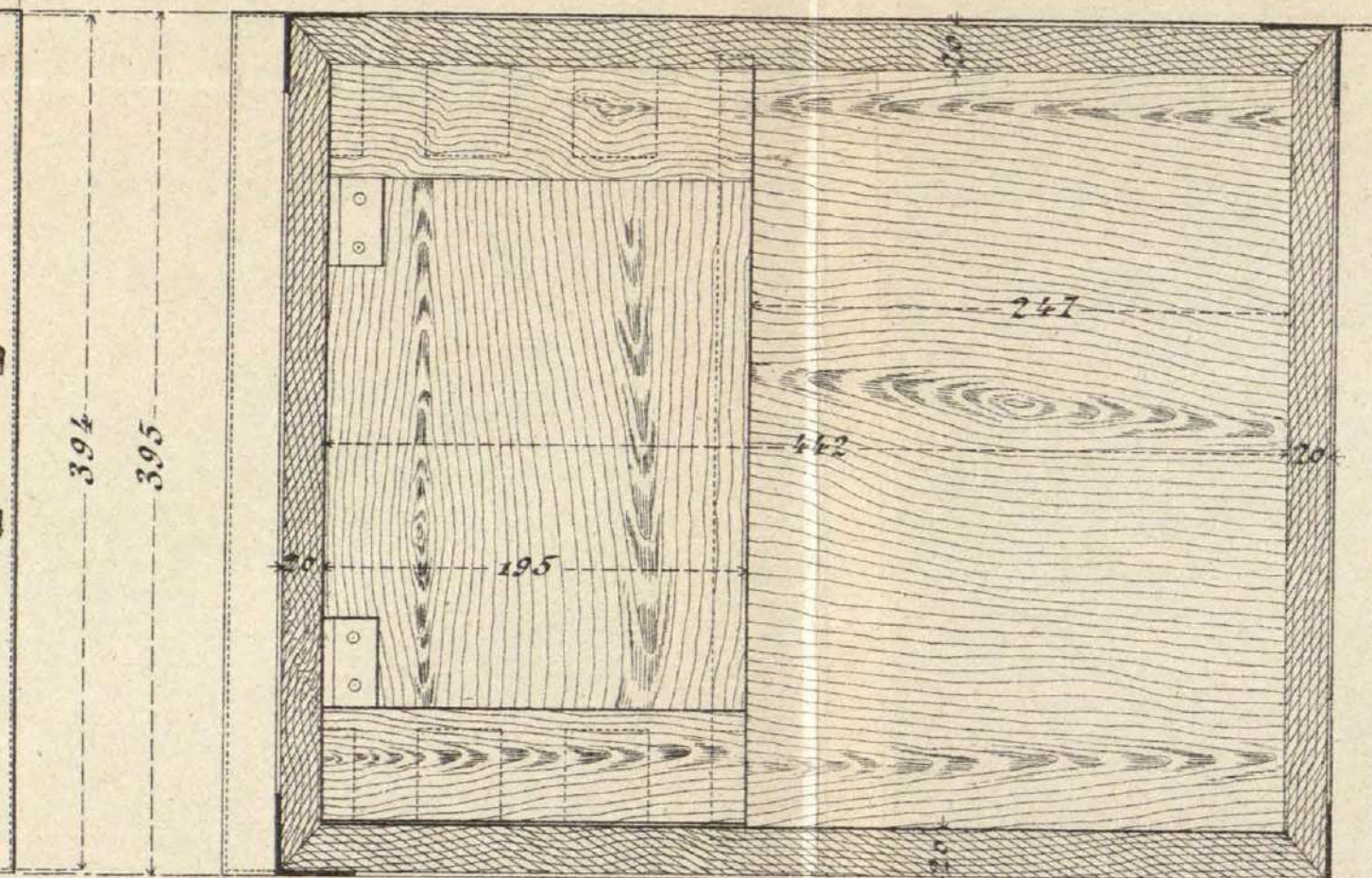
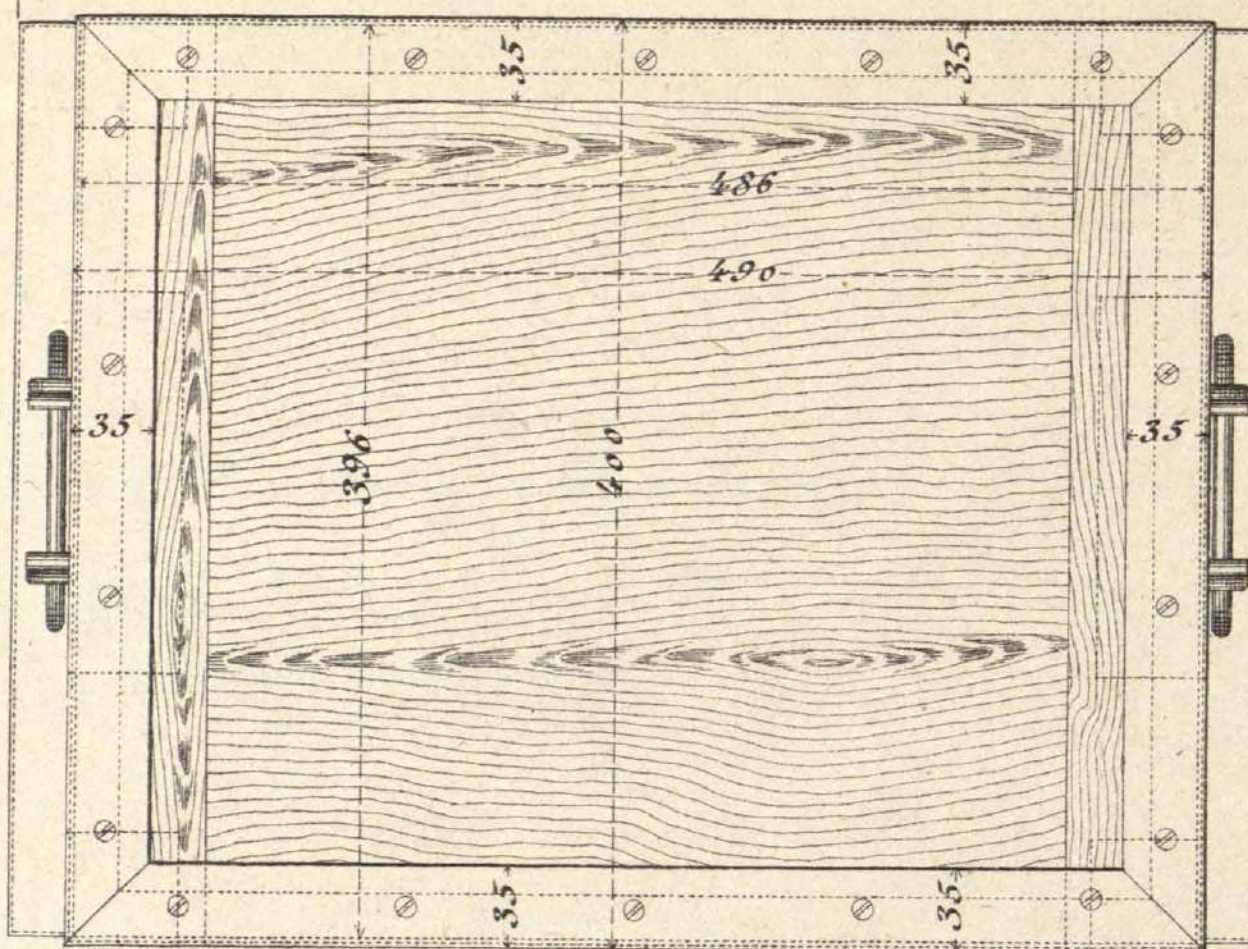
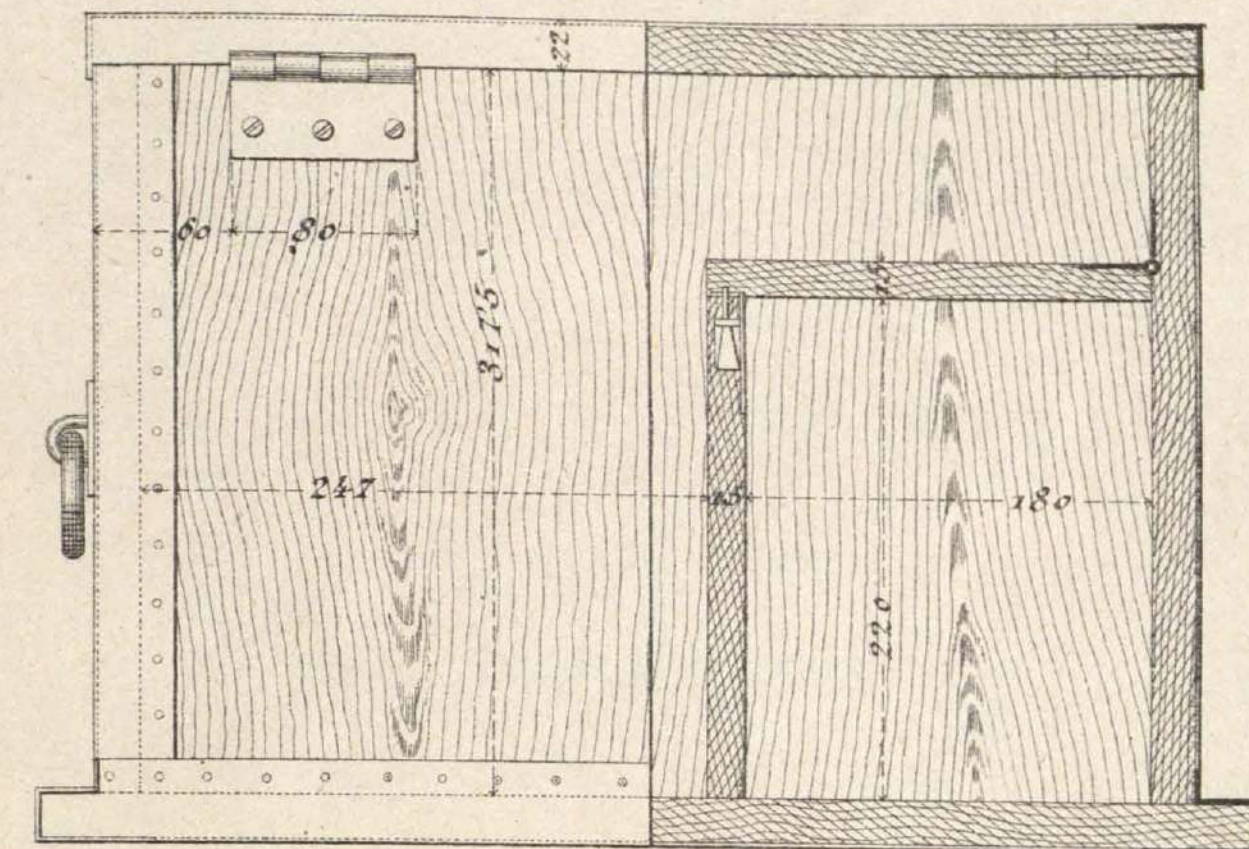

Asa (1/2)

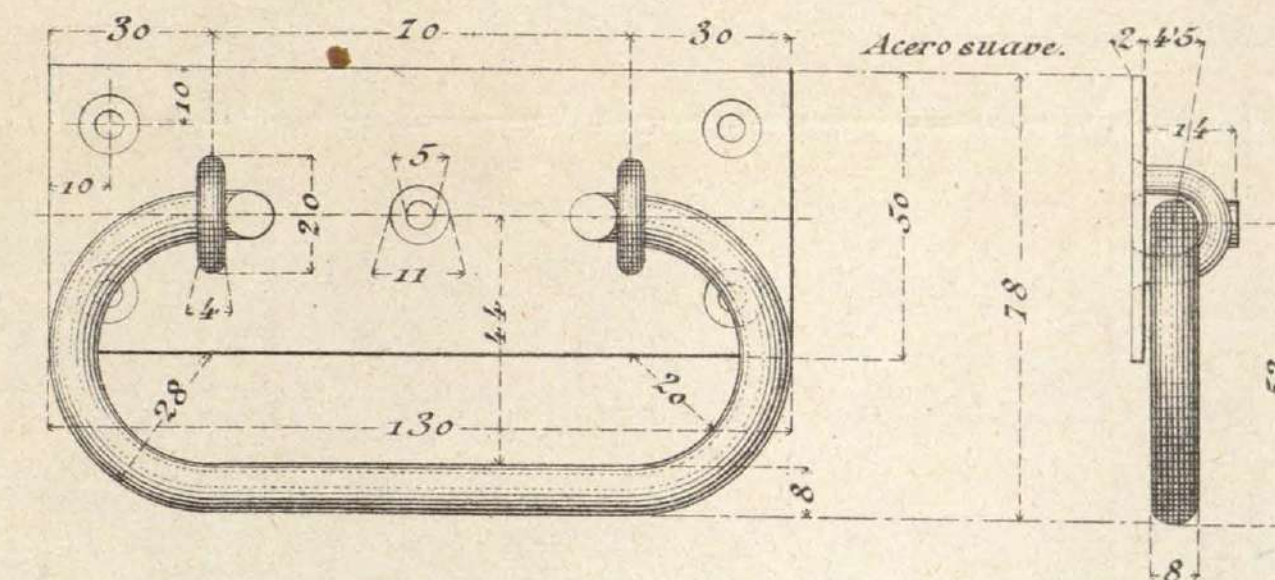

Recercado (1/1)

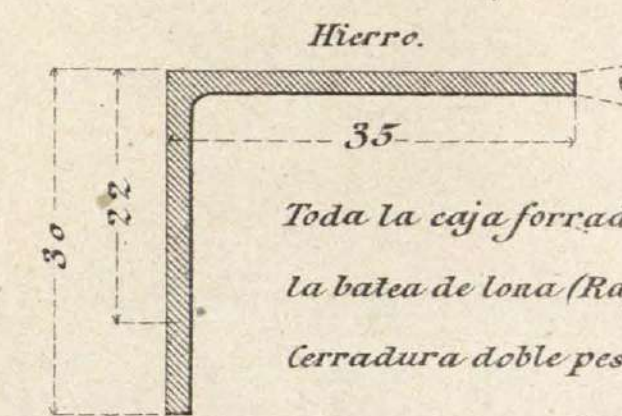

Hierro.

Toda la caja forrada interiormente, lo mismo que la batea de lona (Rayadillo azul y blanco) Cerradura doble pestillo del comercio.

2 Bisagras (4/10)

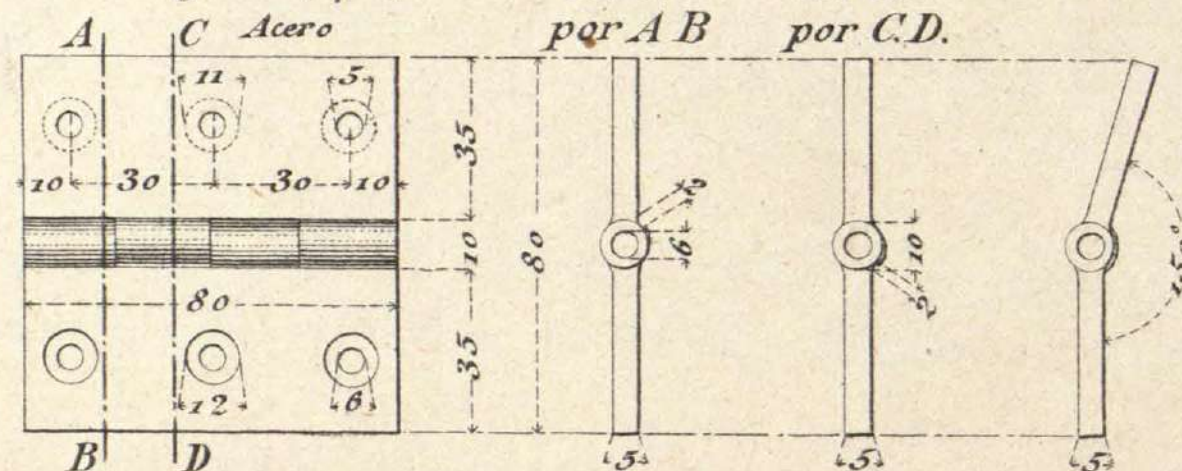

Corte por A B Corte por C.D.

Forros de los resaltes de los fondos (1/1)

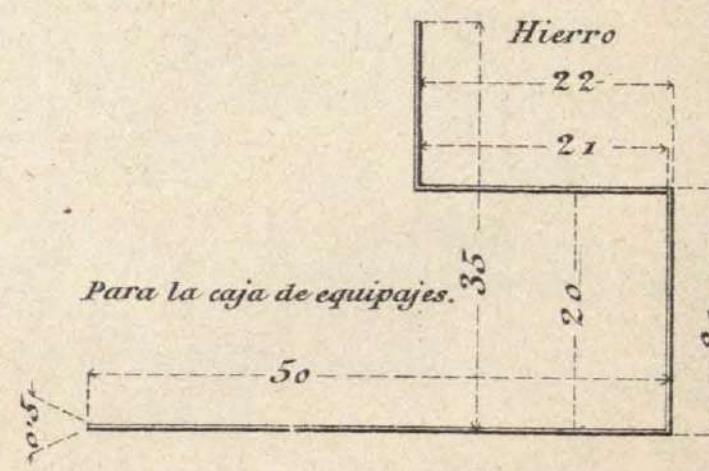

Cantoneras (1/1)

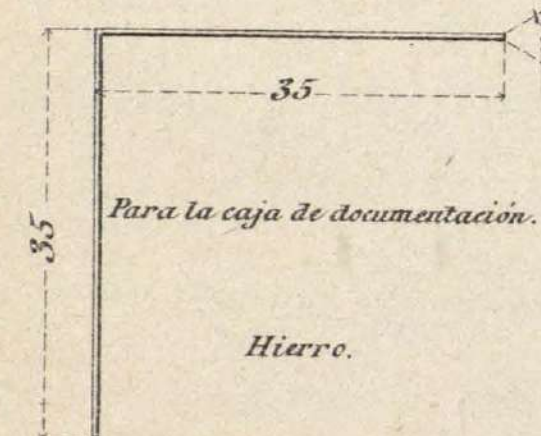

6 Tornillos (1/1)

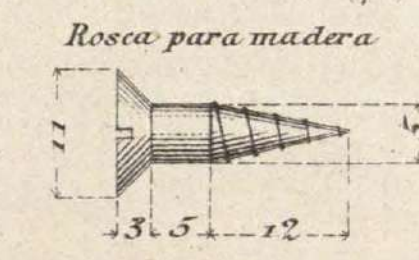

6 Remaches (1/1)

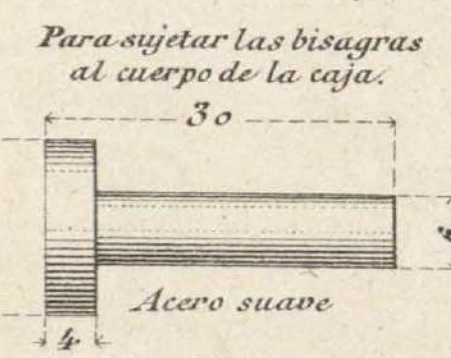

# CARRO DE BATERÍA NÚMERO 1.

Escala  $\frac{1}{5}$

I Caja para cantina y viveres.

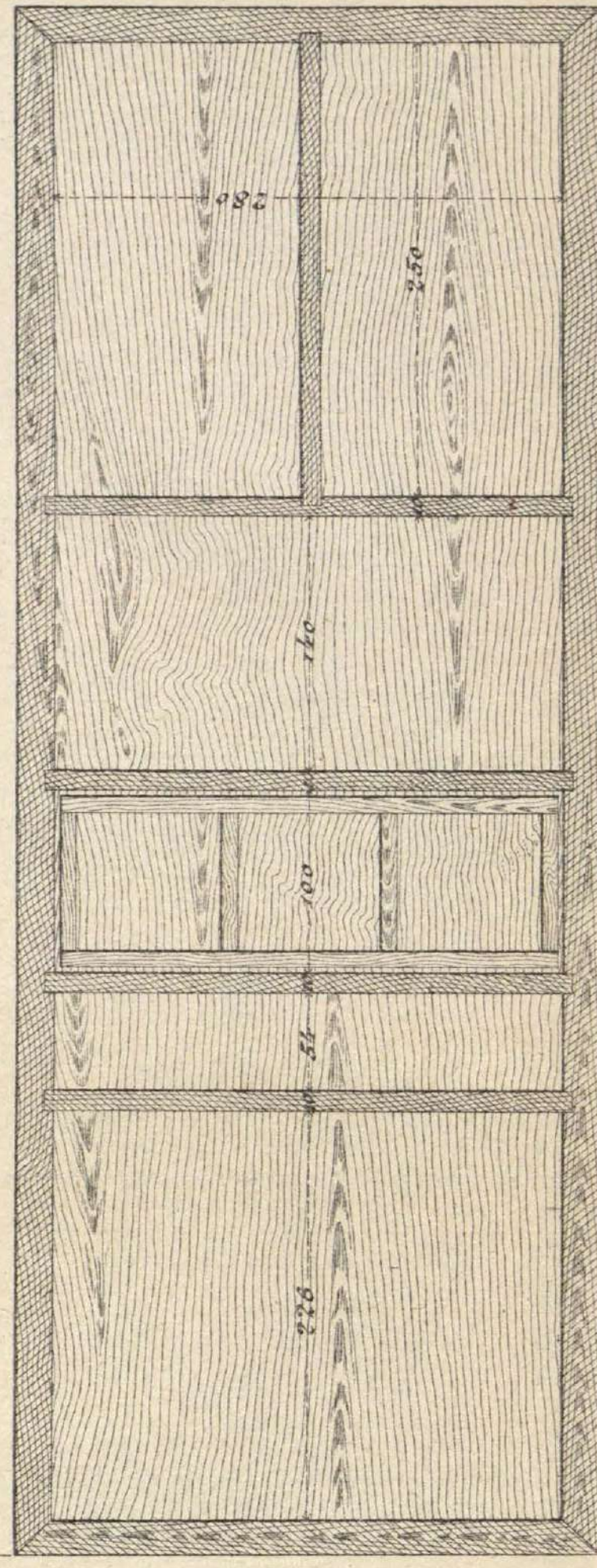
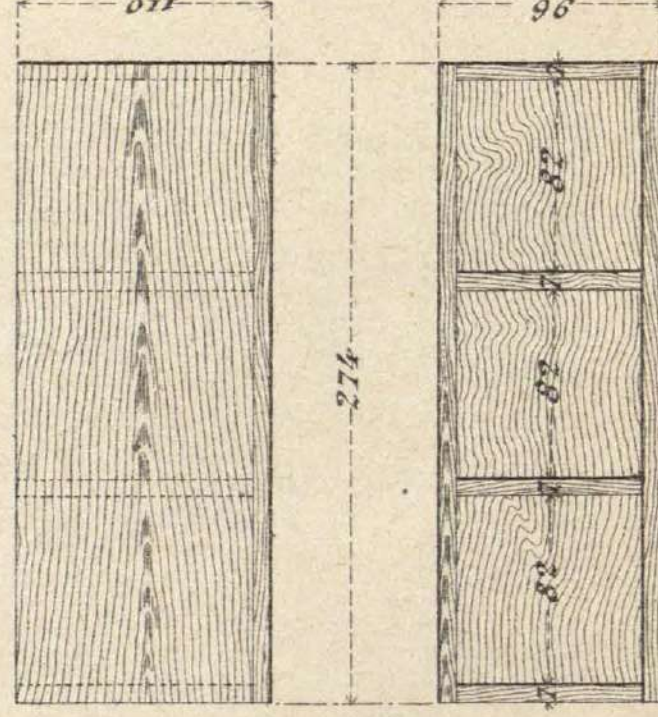
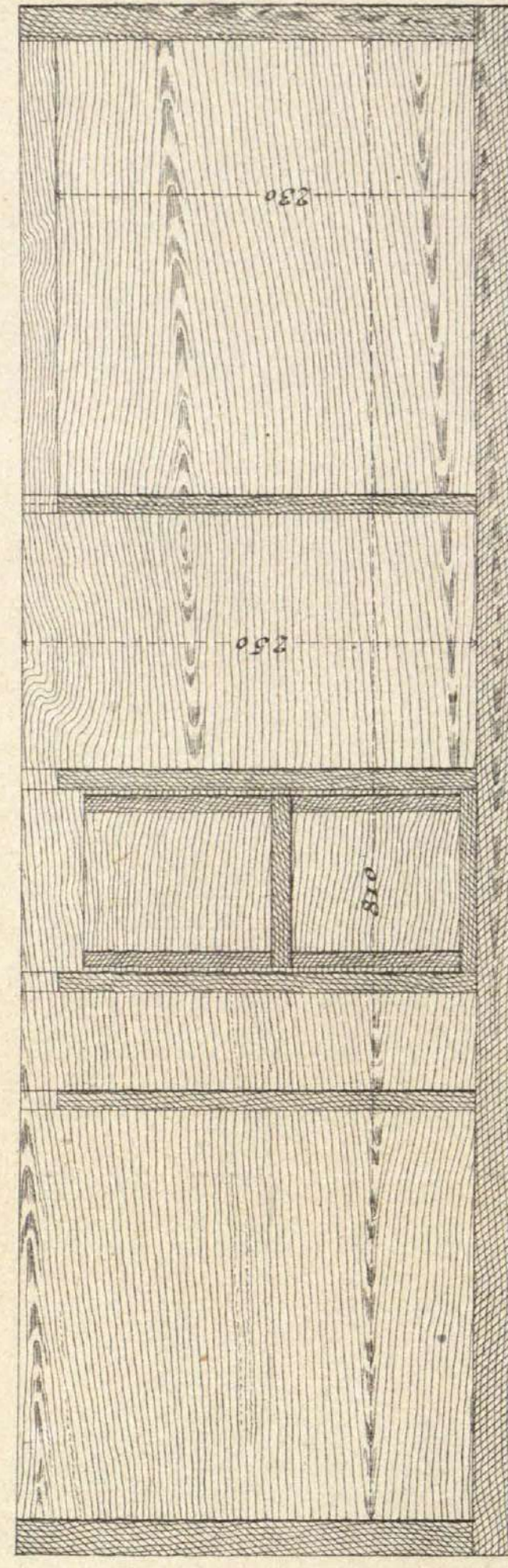
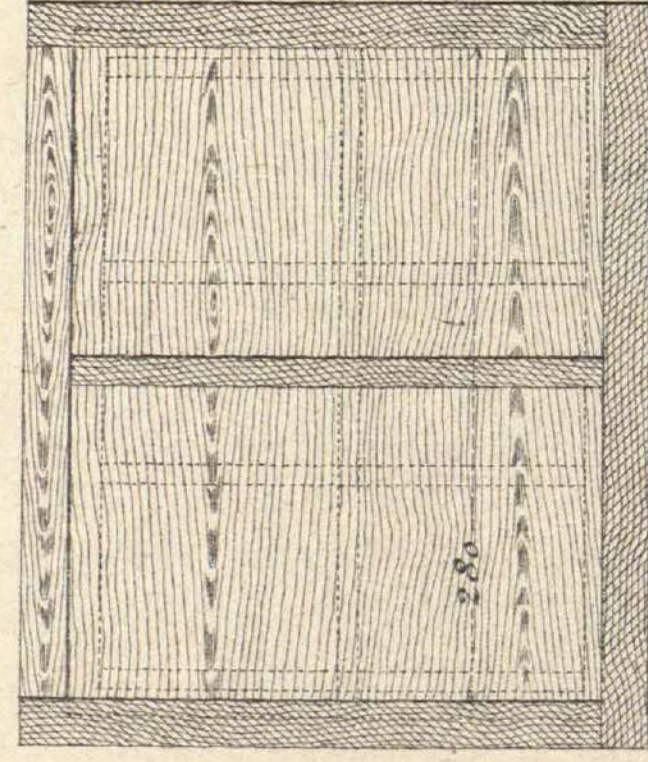

I Caja para respetos y herraduras

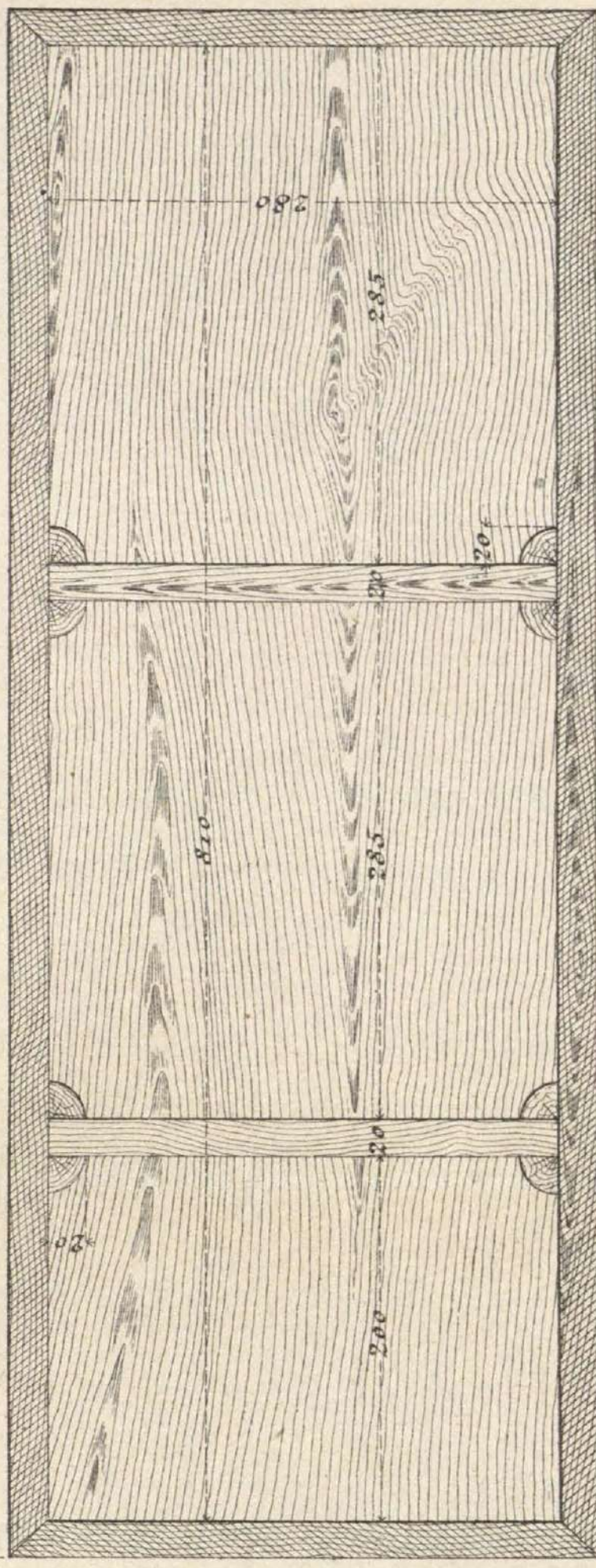
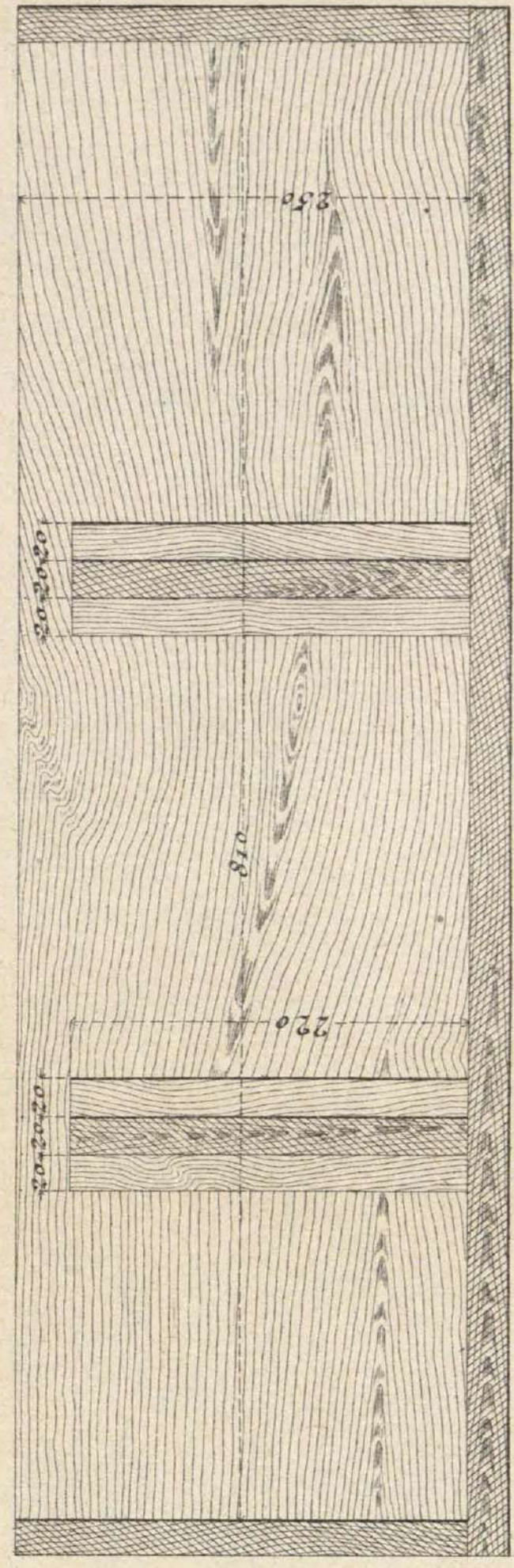
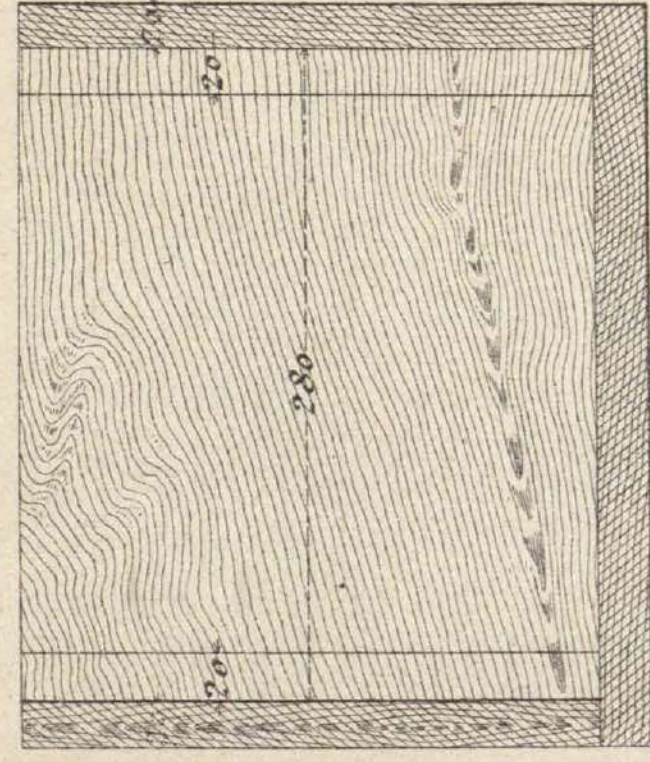

# CARRO DE BATERÍA NÚMERO 1

Caja para botiquín del personal

Sección A B

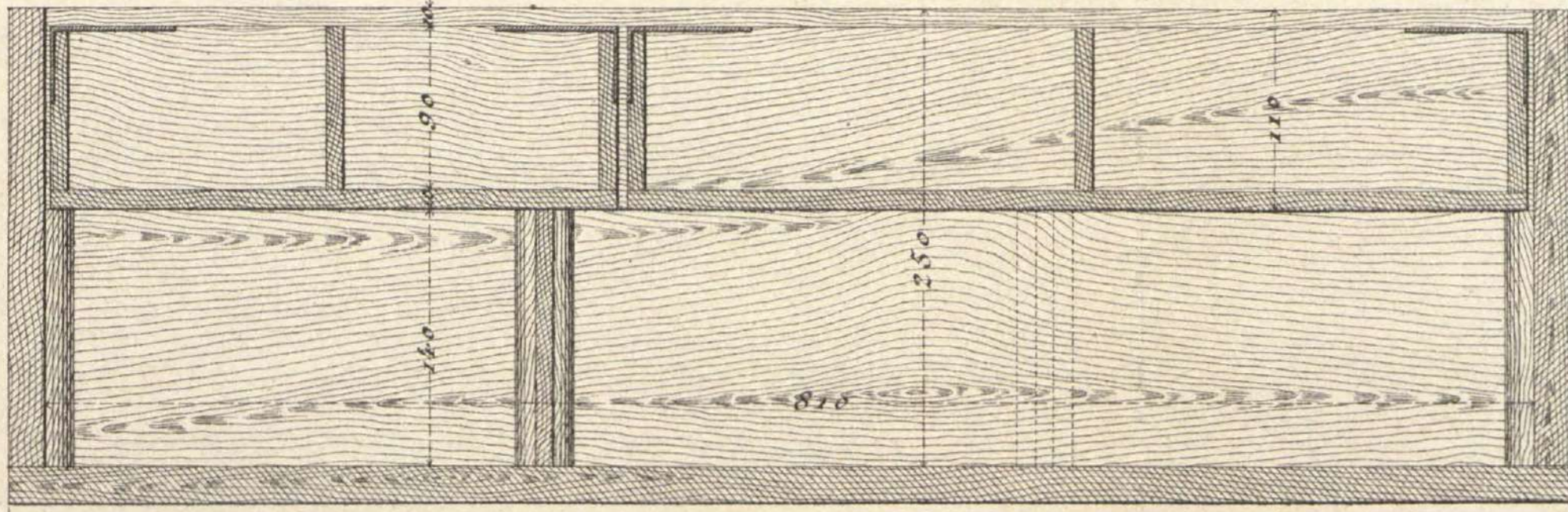

Sección C D

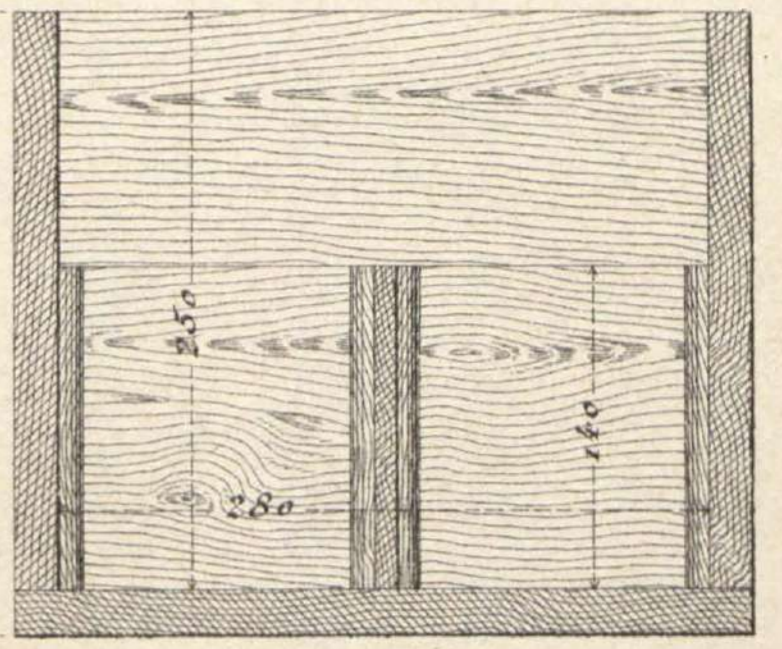

C

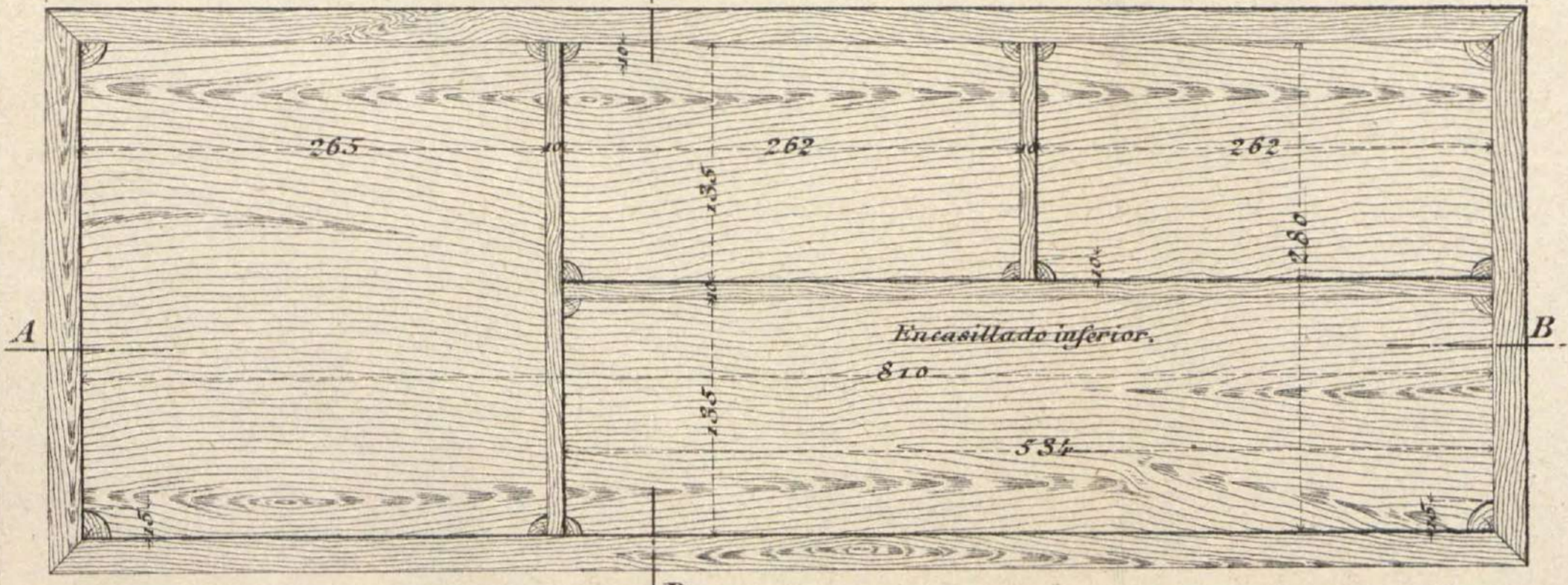

1 Batea

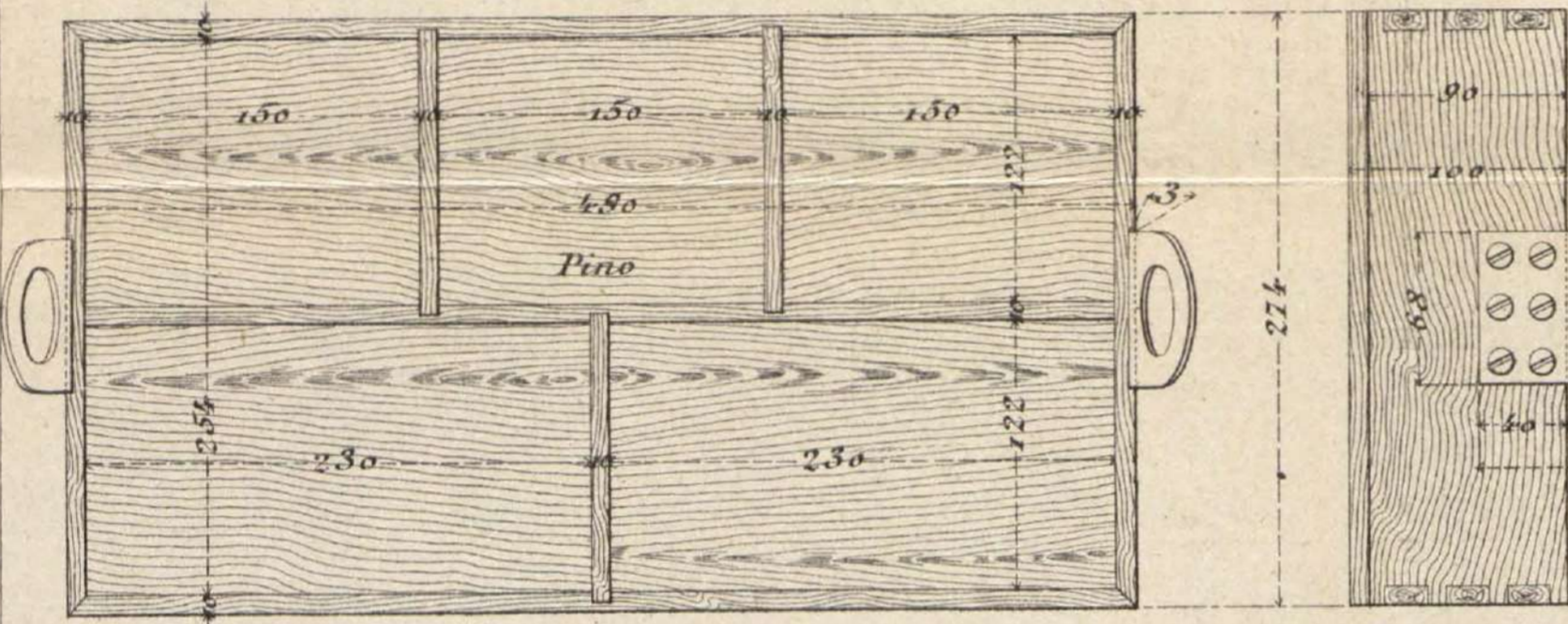

Cuero color avellana

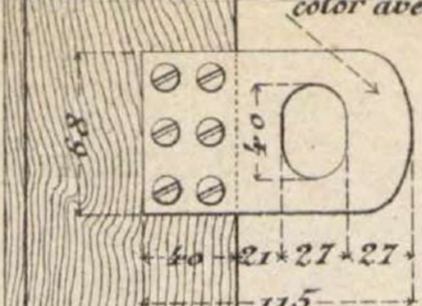

Escala 1/5

Caja para botiquín de ganado.

Sección A B.

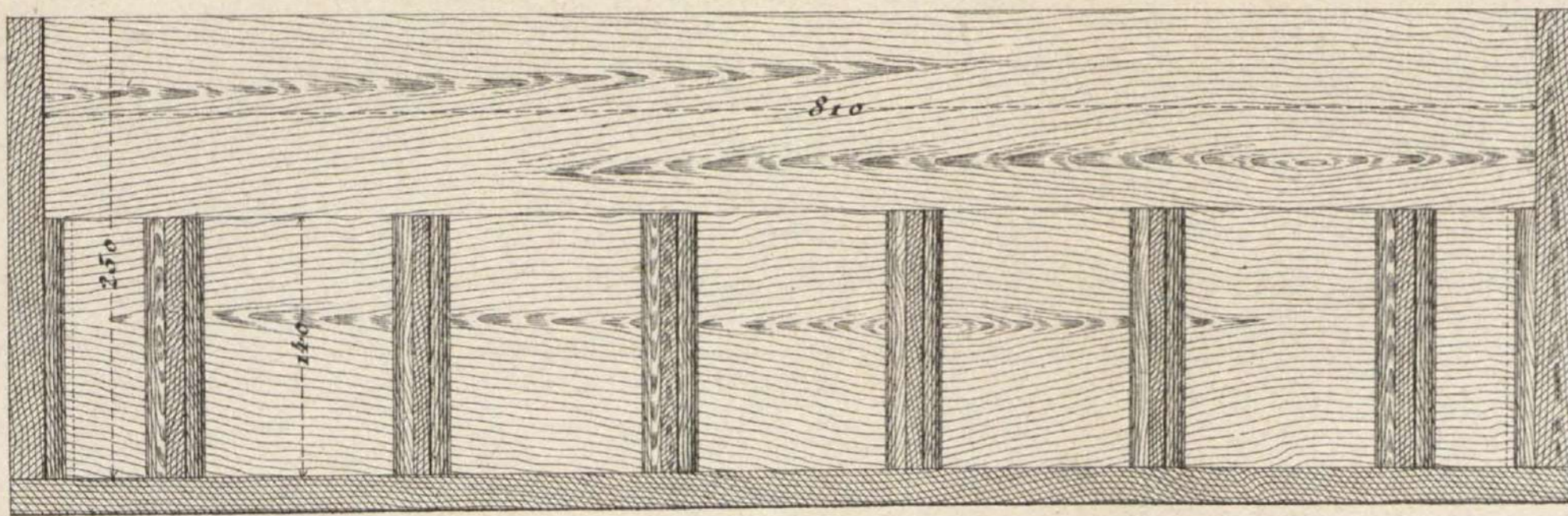

C

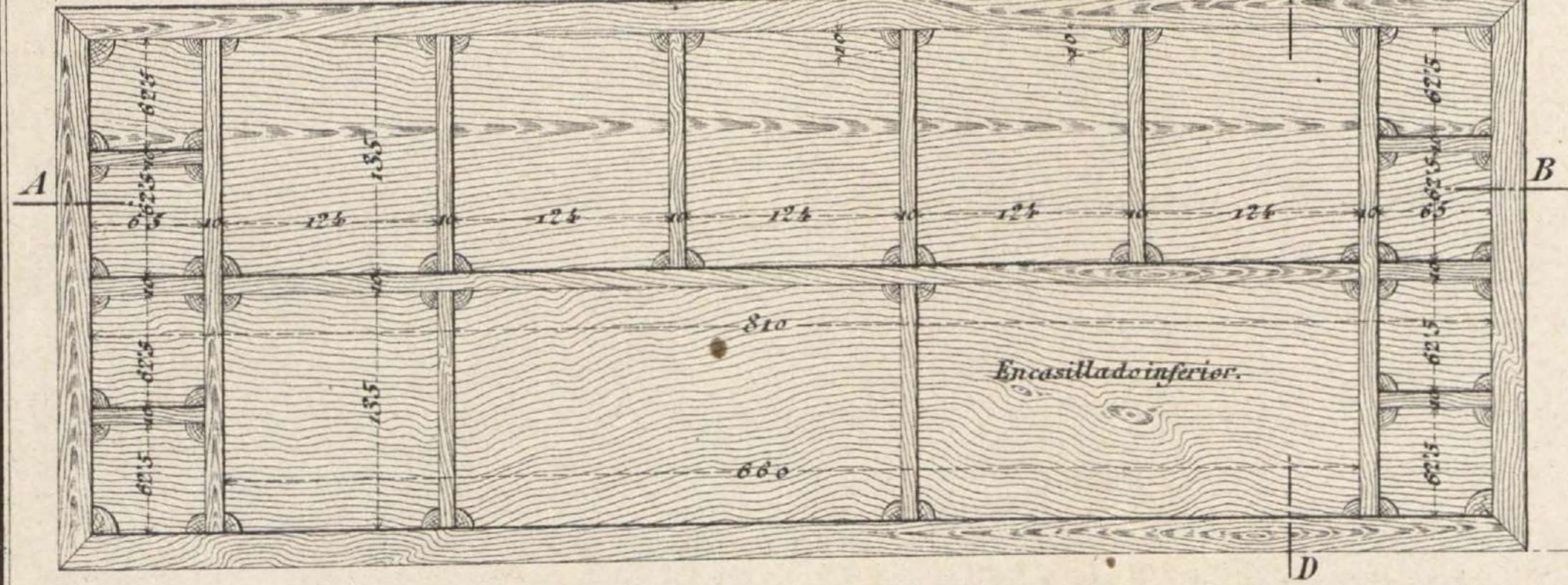

Sección C D

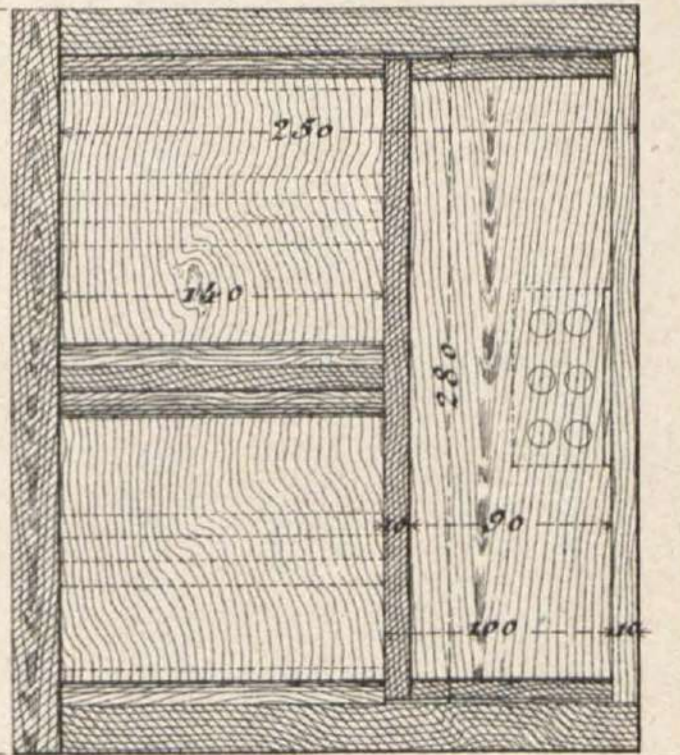

# CARRO DE BATERÍA NÚMERO 1.

Escala 2/10.

4 Cajas para equipaje de oficial.

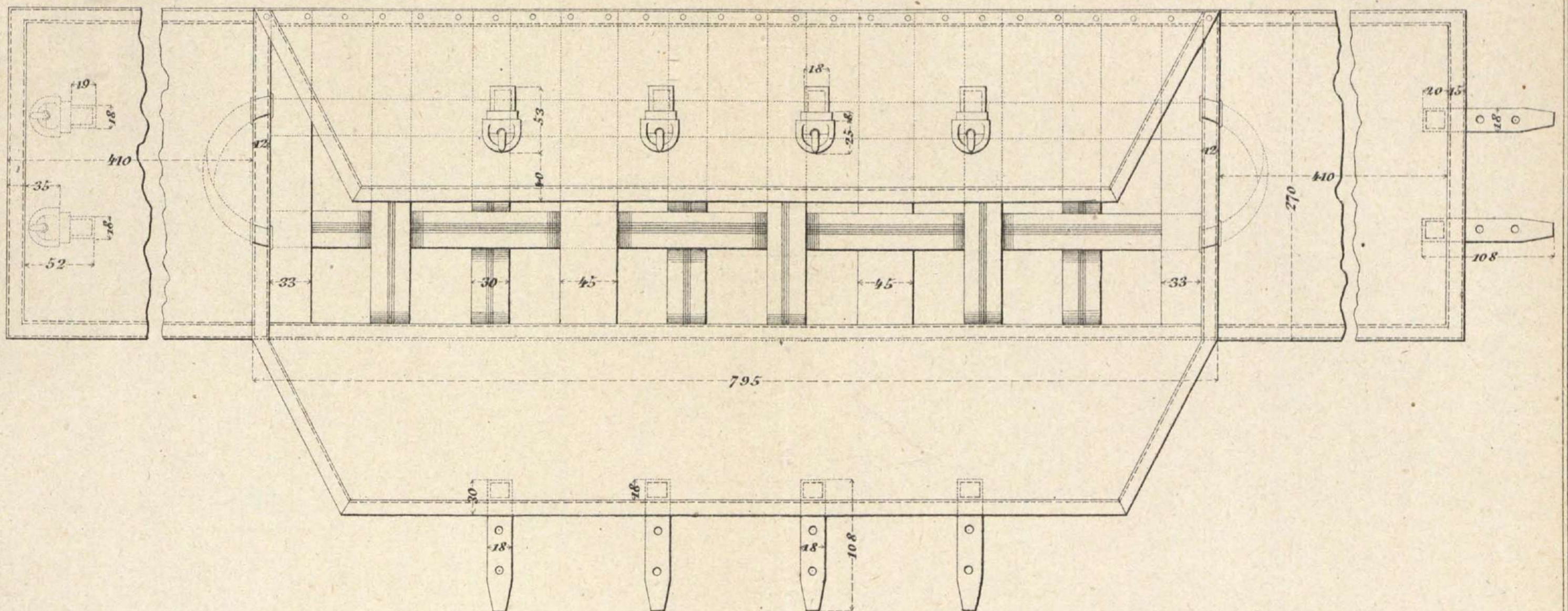
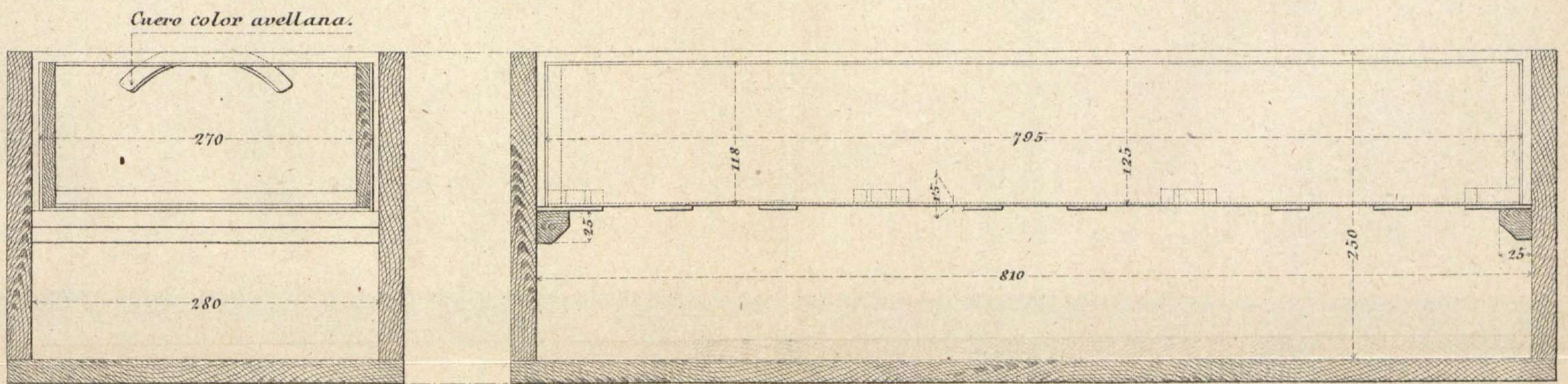
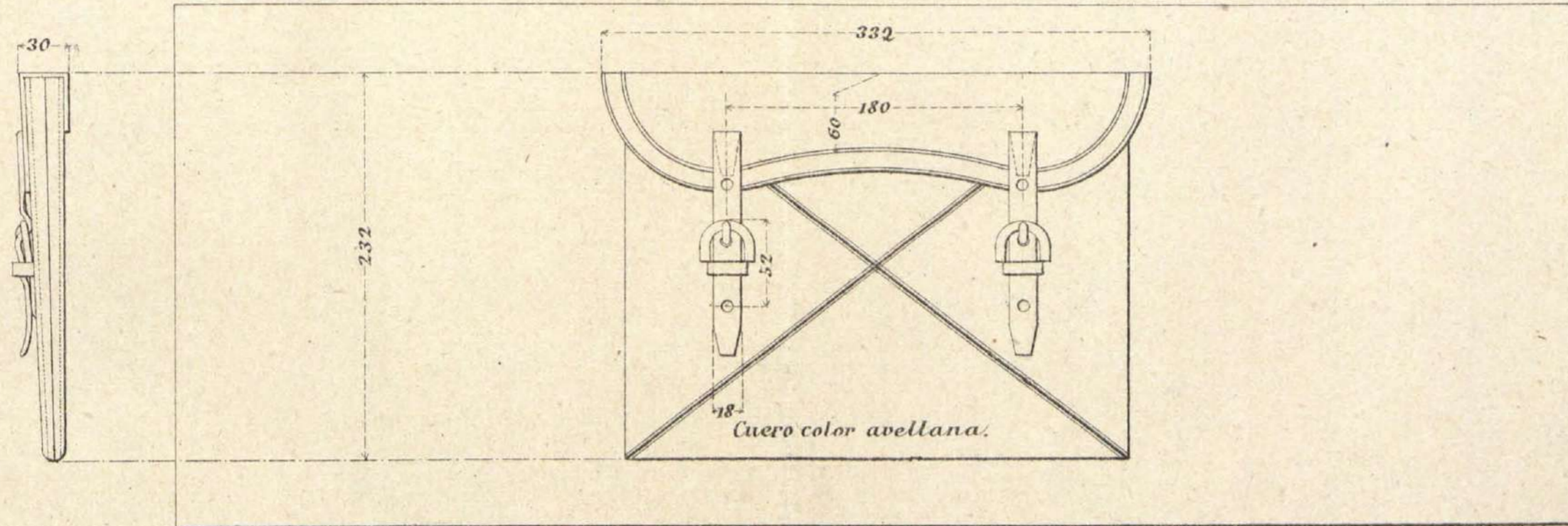

*Toda la caja forrada interiormente lo mismo que la batea de lona, (rayadillo azul y blanco.)*





# CARRO DE BATERÍA NÚMERO 2. LECHO Y ESCUADRAS.

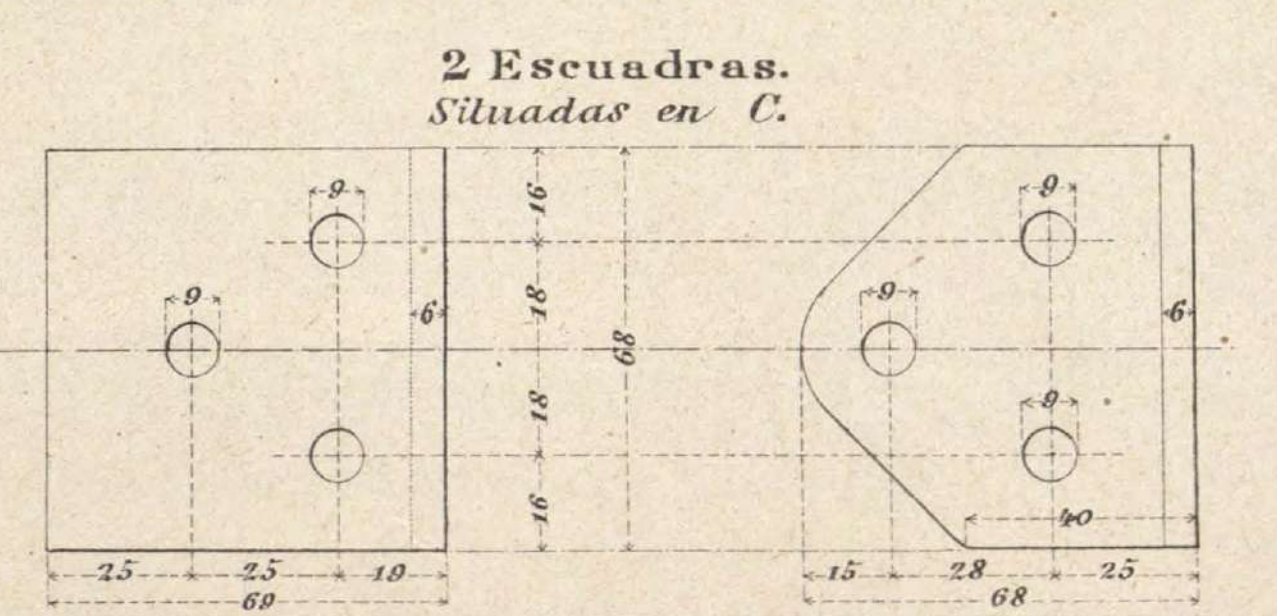
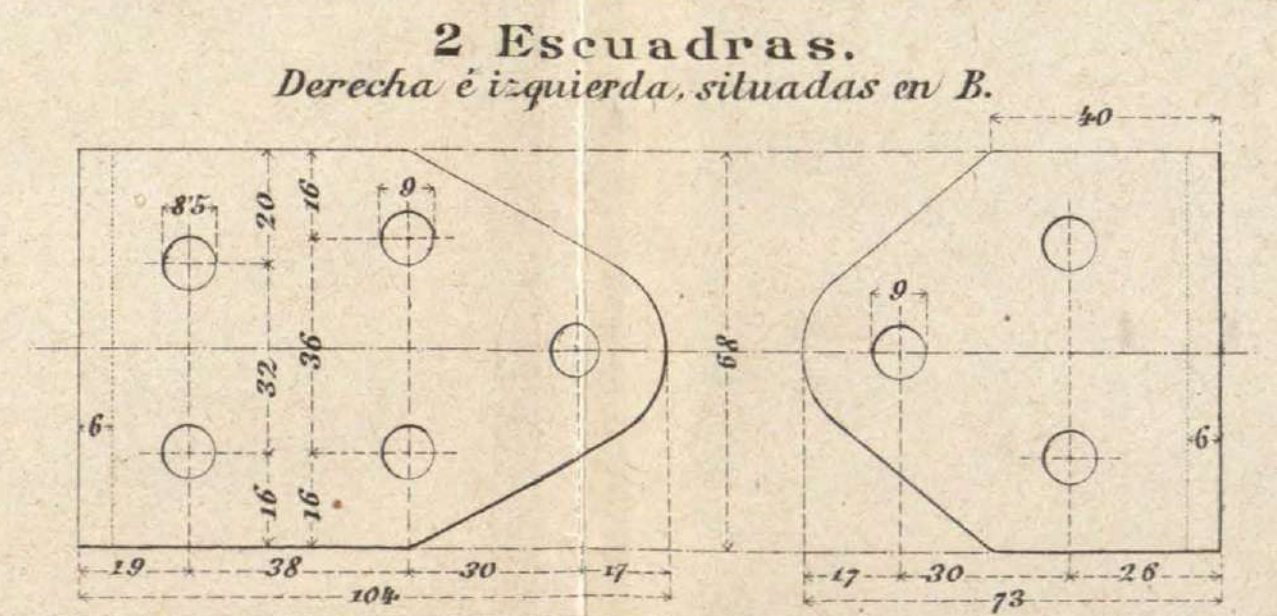
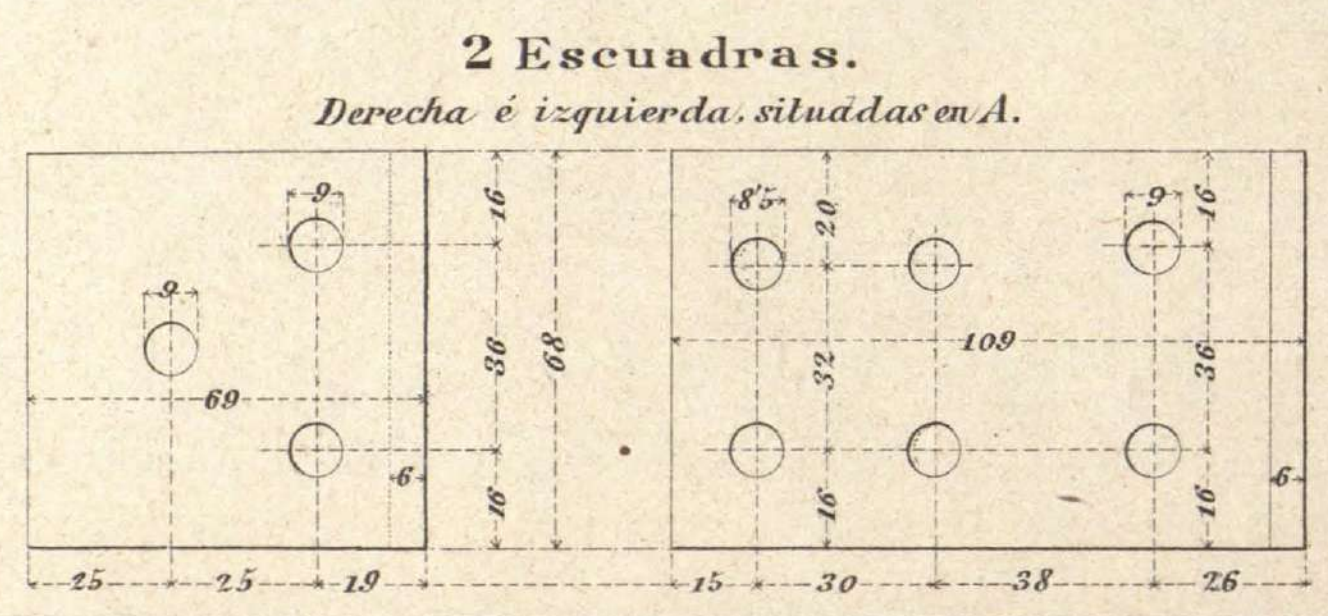
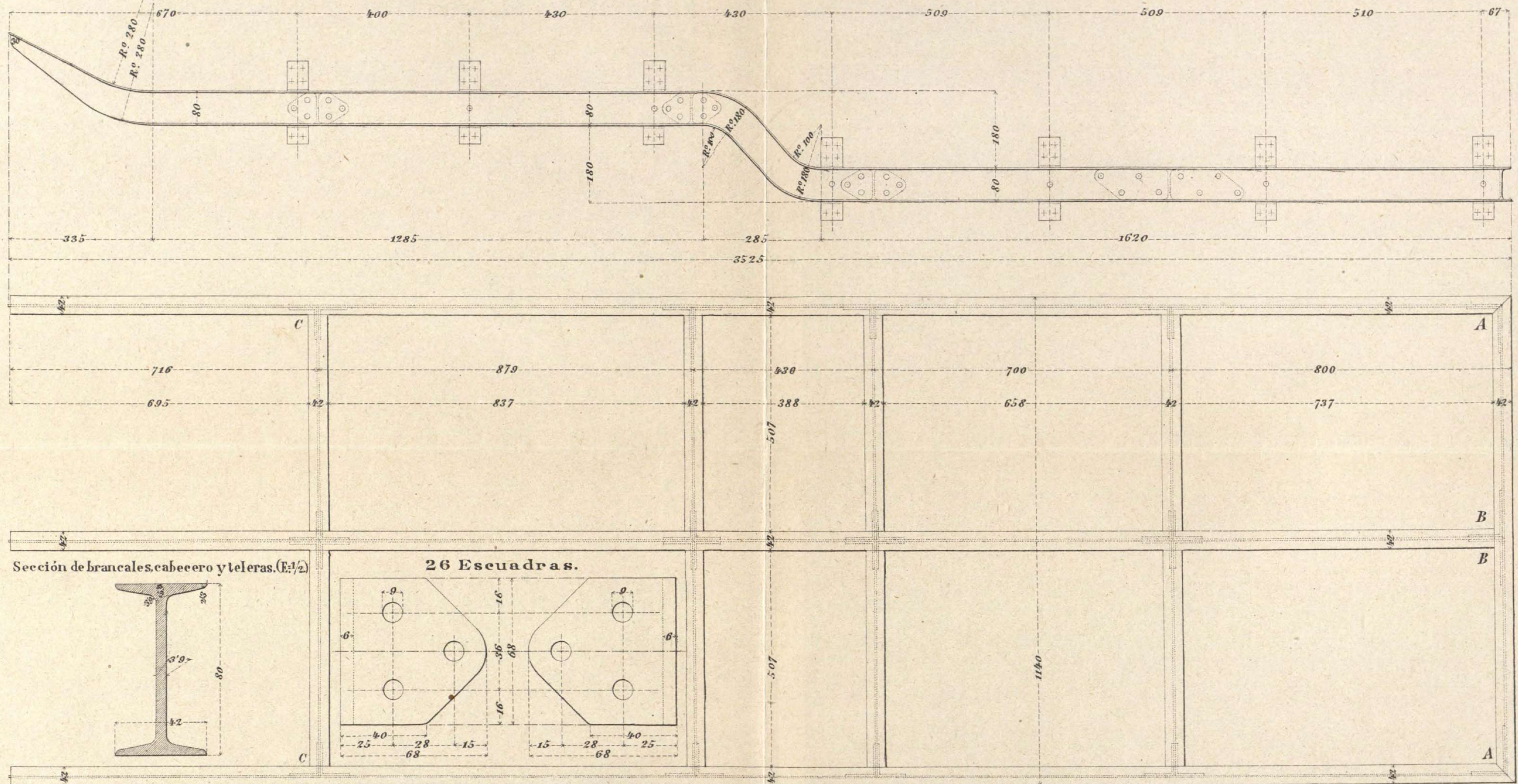

# CARRO DE BATERÍA NUMERO 2

## DE TALLES

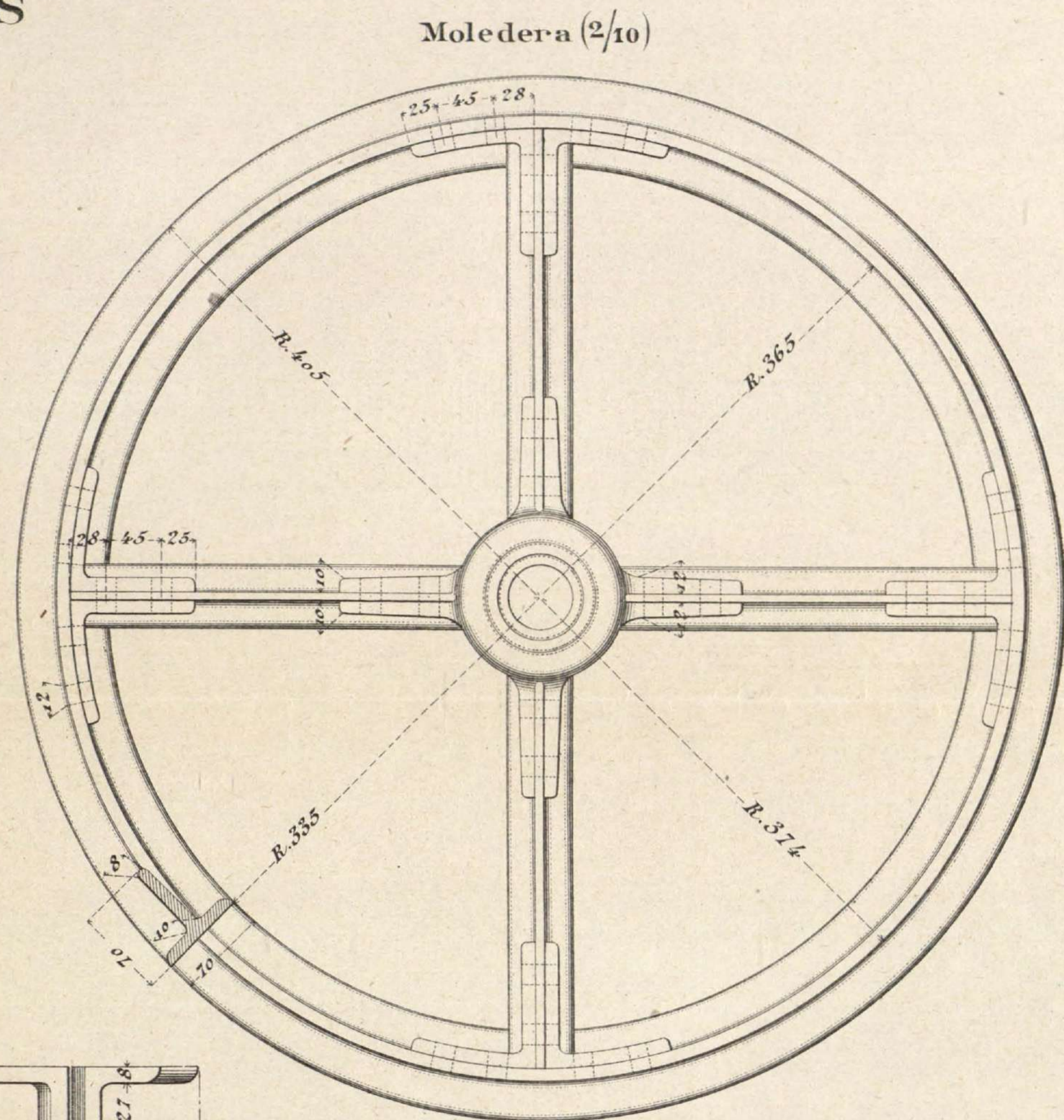
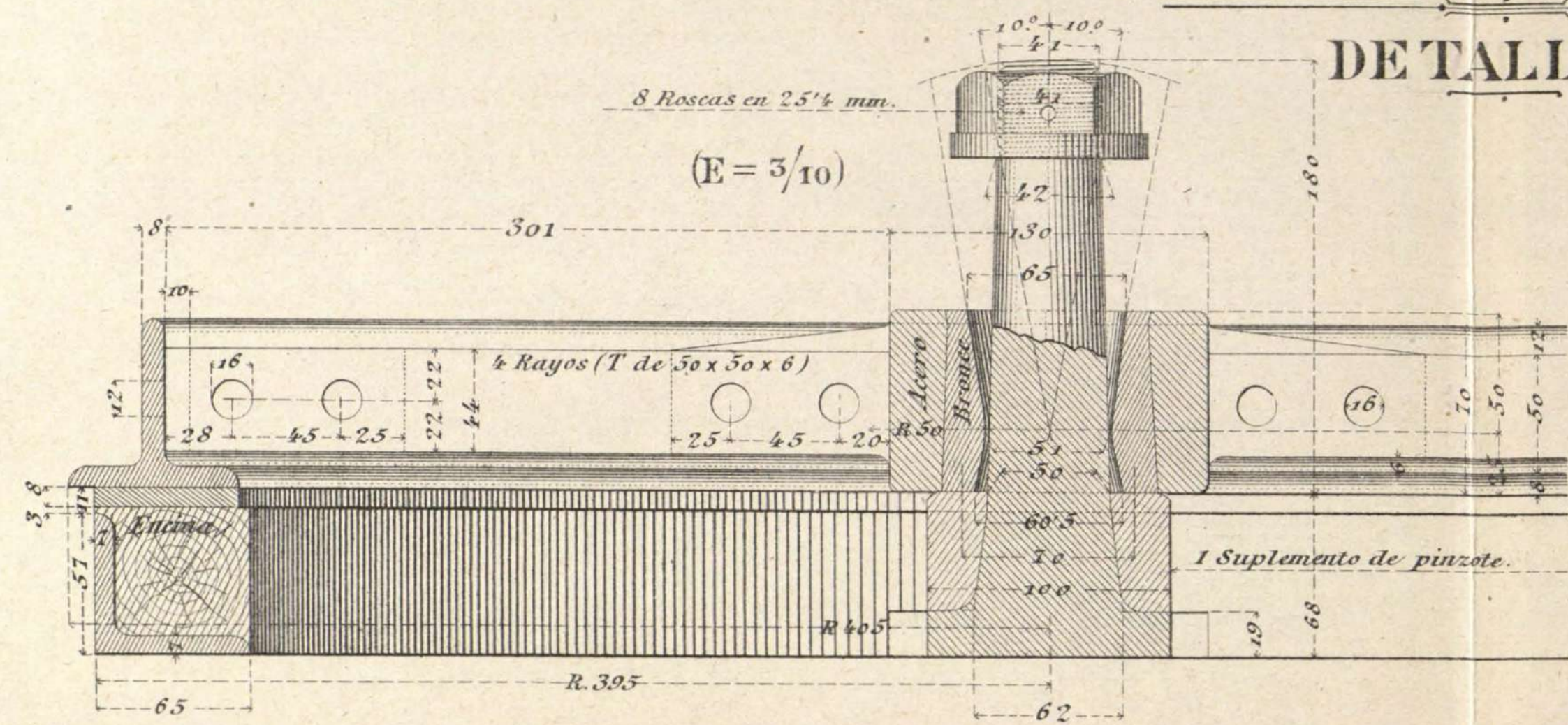

Tornapunta de la moladera ( $\frac{3}{10}$ )

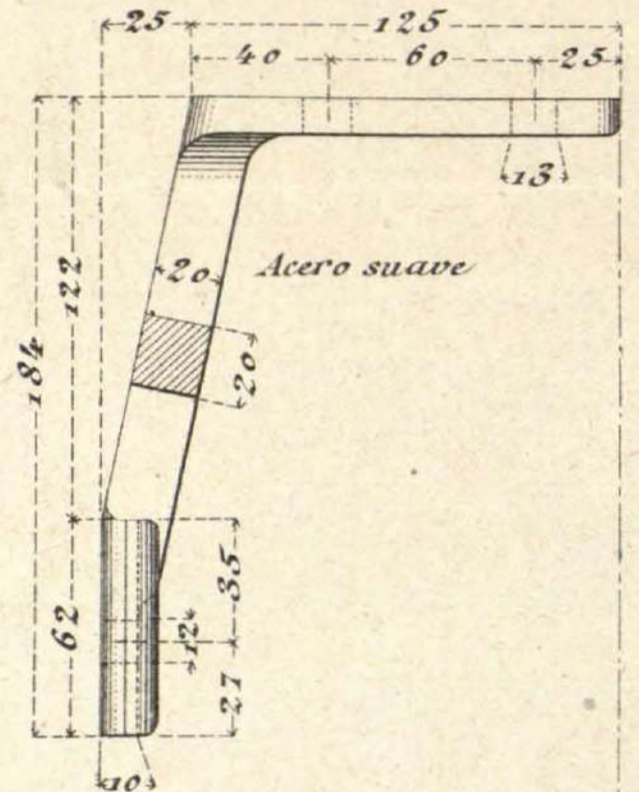

8 Escuadras ( $\frac{1}{2}$ )

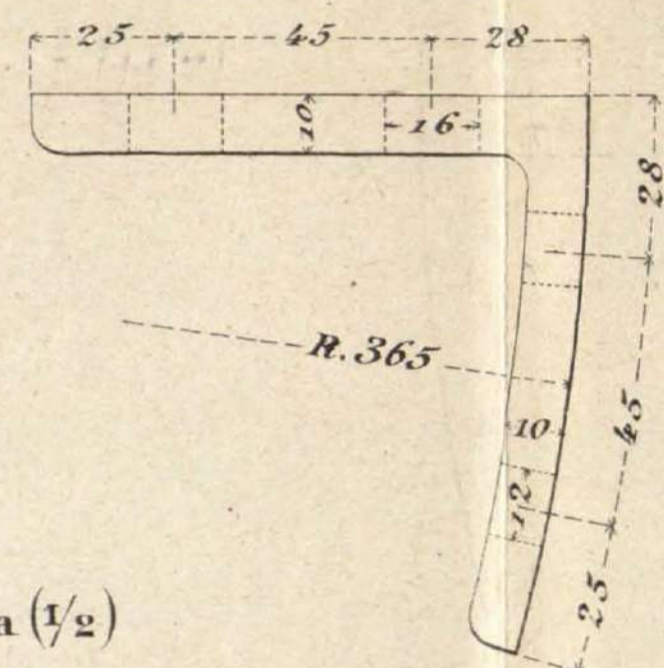

1 Cruceta ( $\frac{1}{2}$ )

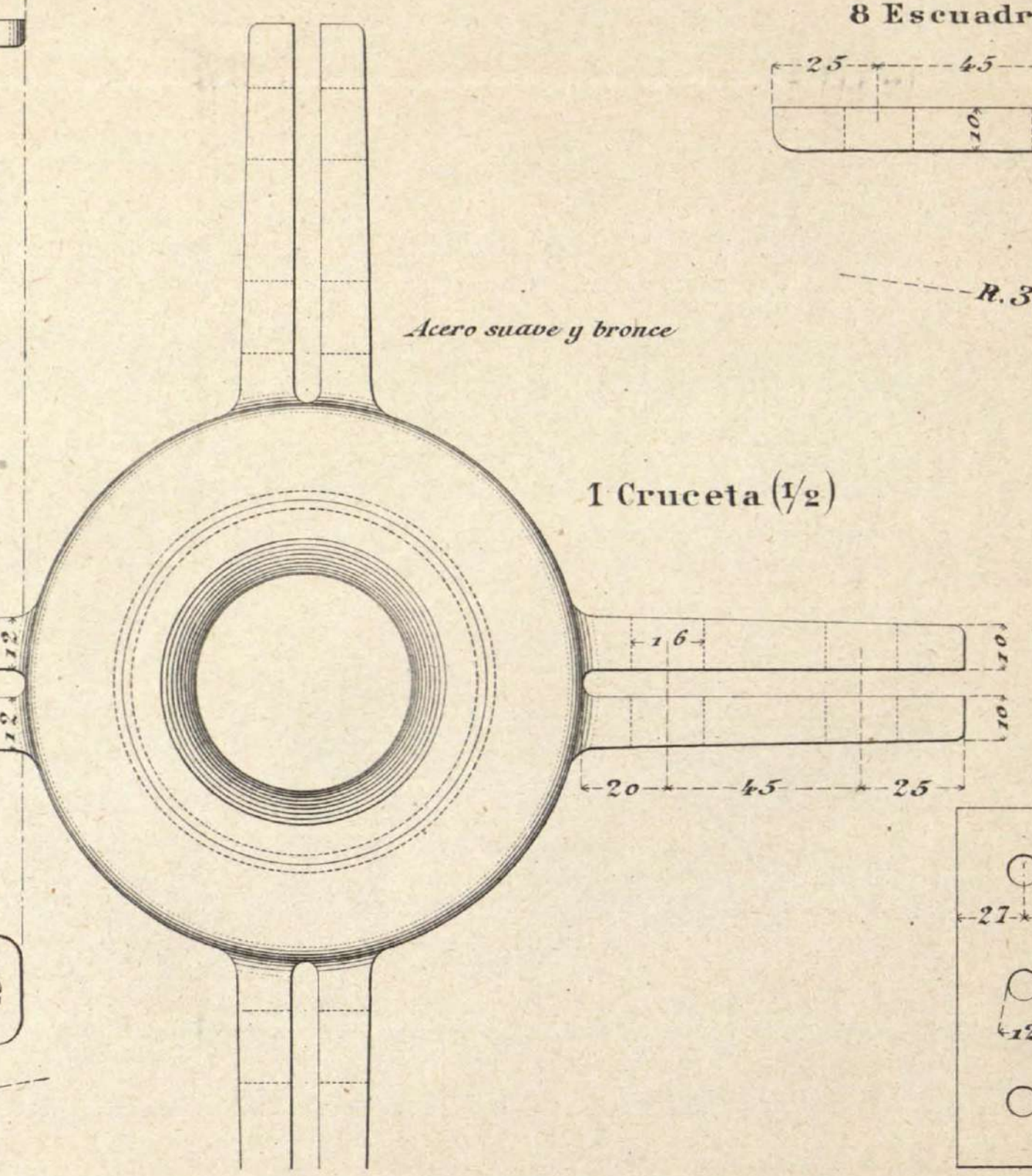

Escuadras de unión de la moladera al lecho. ( $\frac{3}{10}$ )

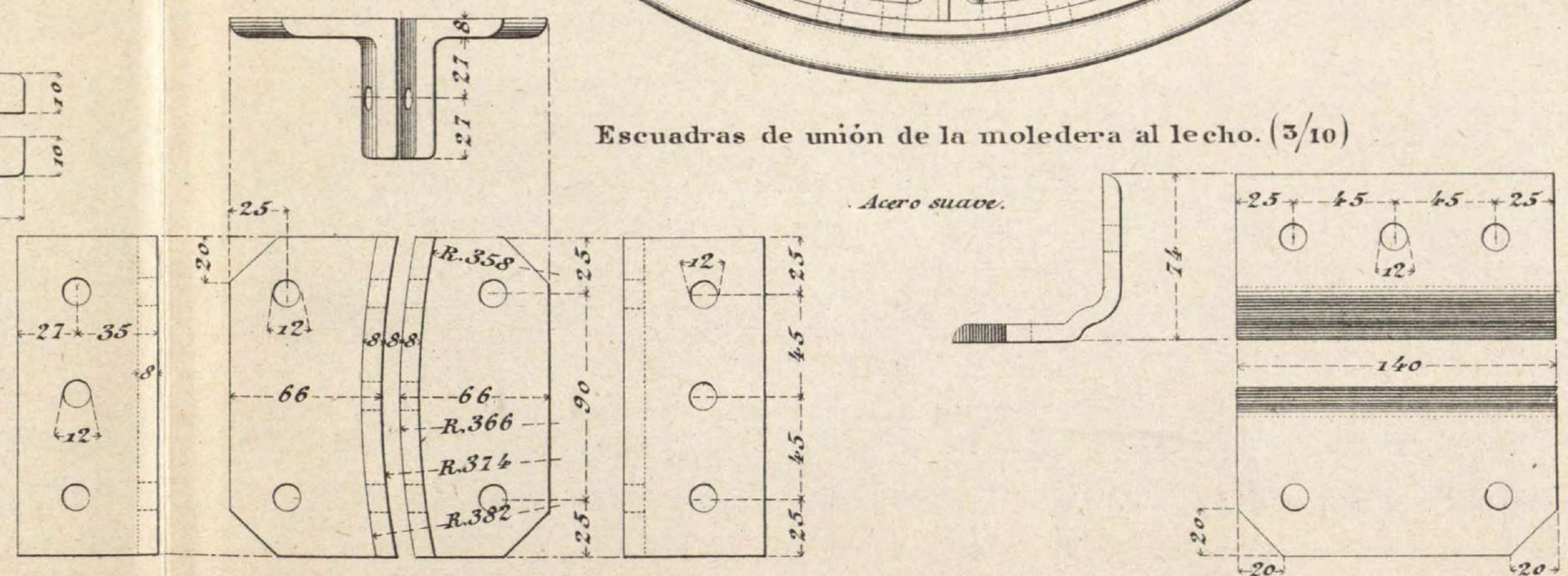





# CARRO DE BATERÍA NÚMERO 2.

## DETALLES.

Mangas en ambos ejes iguales  
à las del carro n.º 1.  
Ruedas traseras, las mismas.

Eje trasero. Sección rectangular. (E = 2/10.)  
Acero.

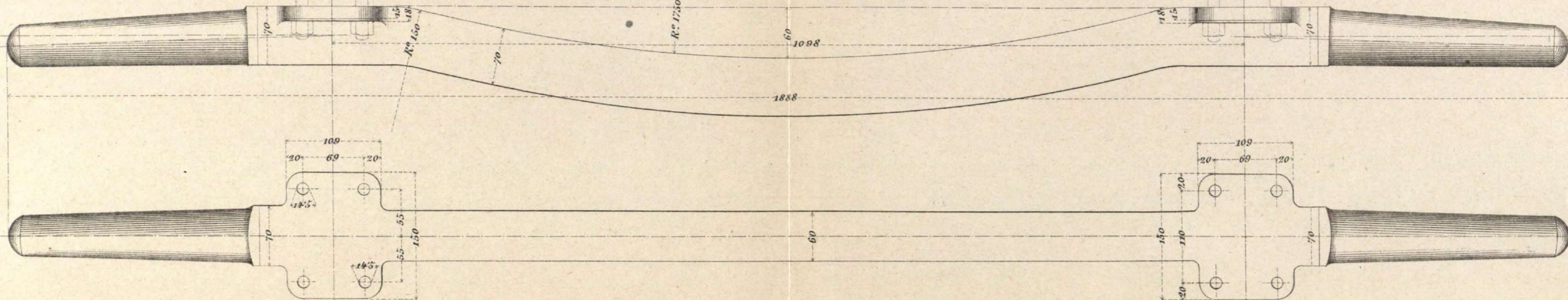

Eje delantero. Sección cuadrada. (E = 2/10.)  
Acero.

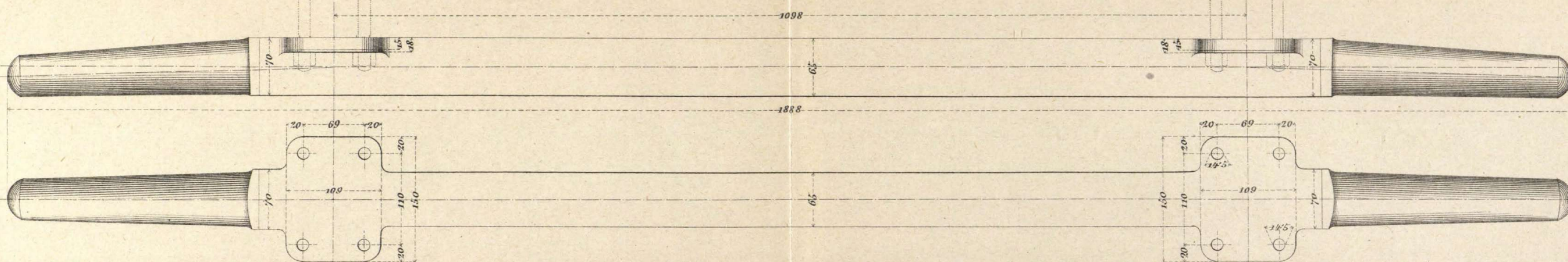

4 Volanderas exteriores. (E = 5/10.)

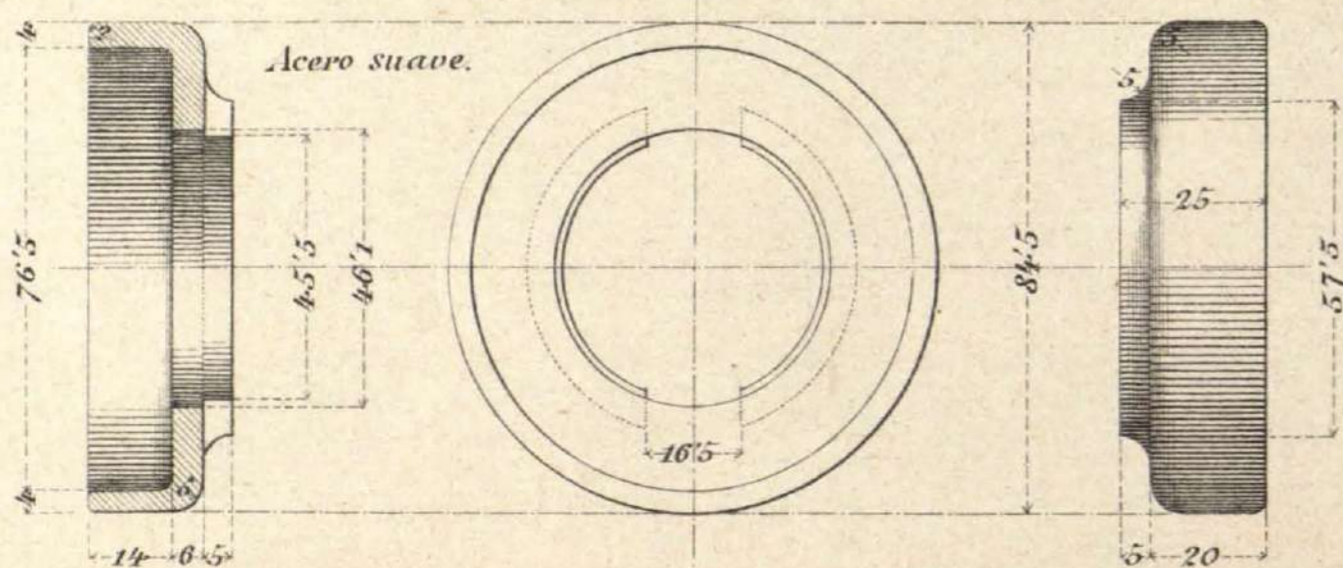

4 Volanderas interiores. (E = 5/10.)

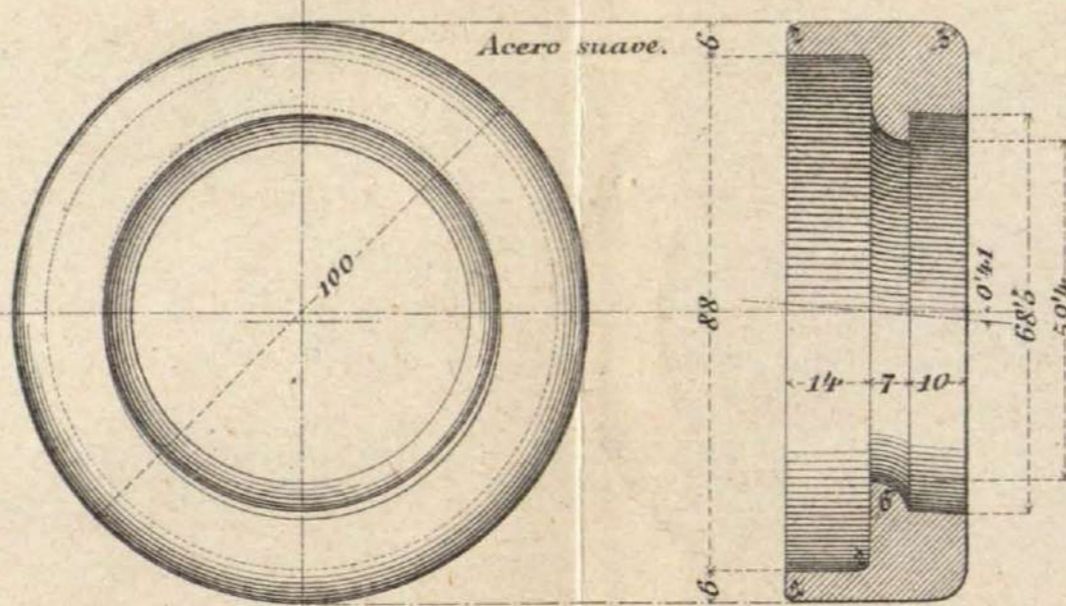

6 Anillas de sobre-carga. (E = 5/10.)

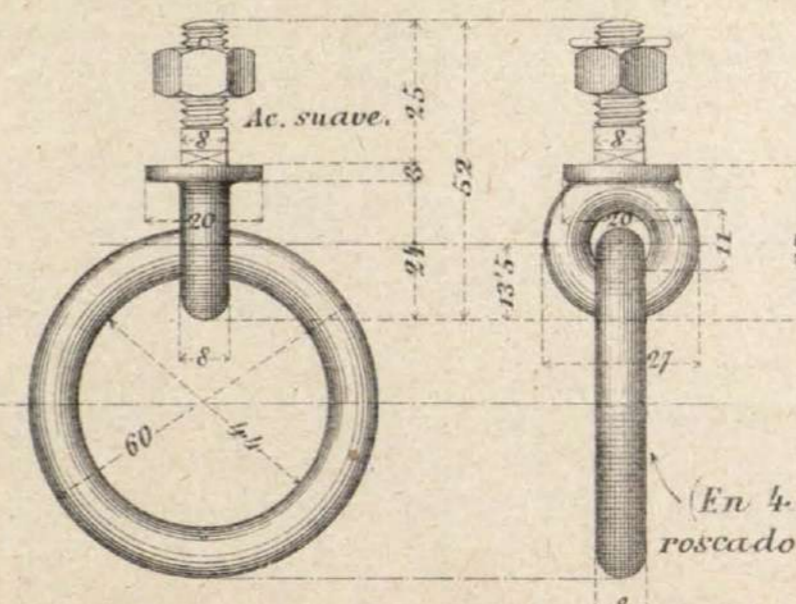

2 Sotrozos del juego trasero. (E = 5/10.)

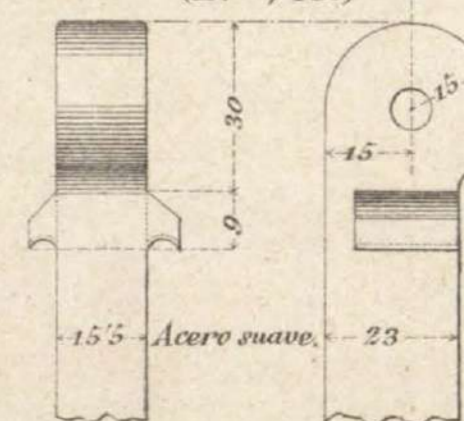

(En 4 de ellas el pezon  
roscado 8 mm. más corto.)



# CARRO DE BATERIA NÚMERO 2

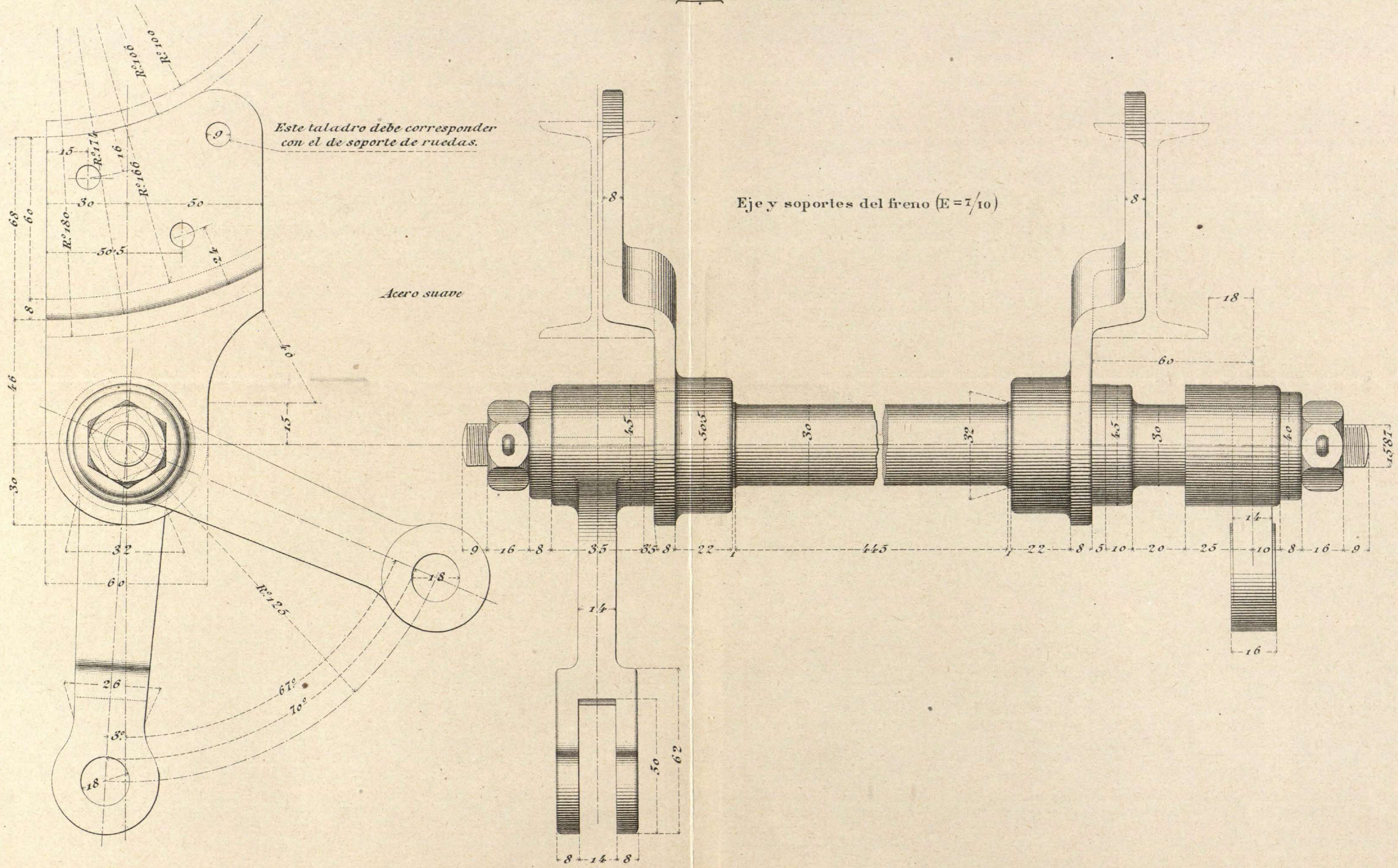



# CARRO DE BATERÍA NÚMERO 2

## DETALLES

1 Cerrojo de la compuerta (E=4/10)

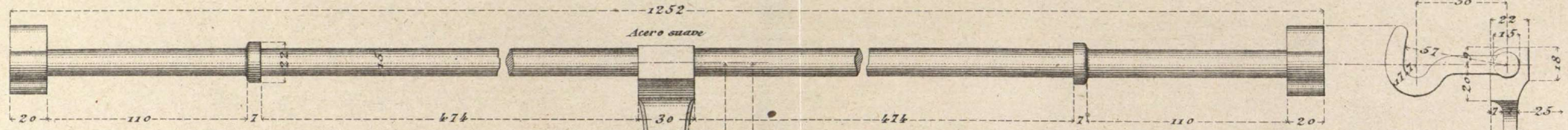

4 Bridas de los sotrozos (E=6/10)

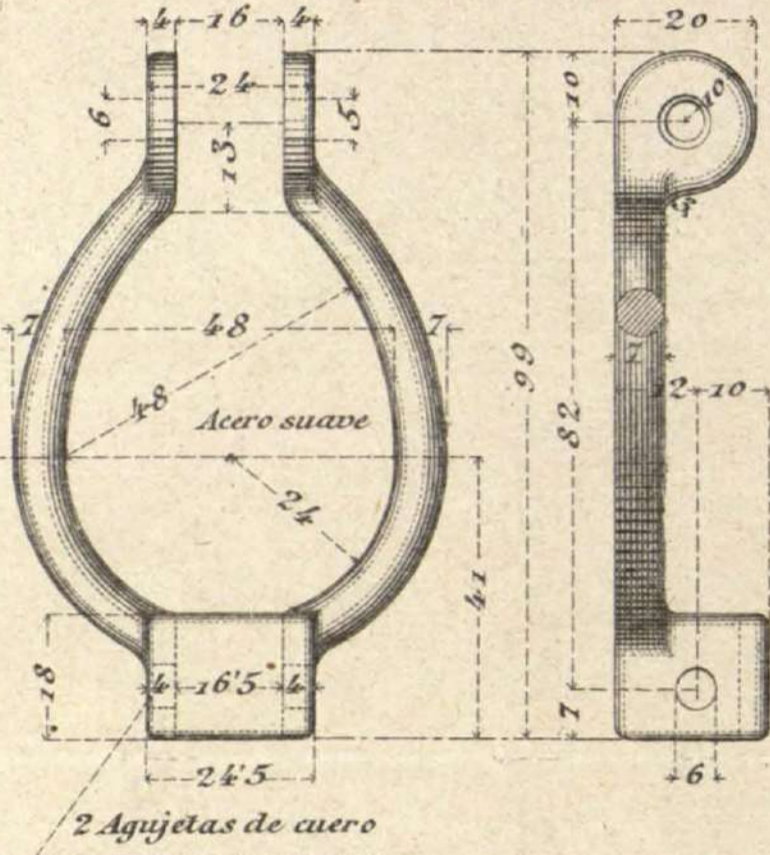

2 Pezones del cerrojo (E=4/10)

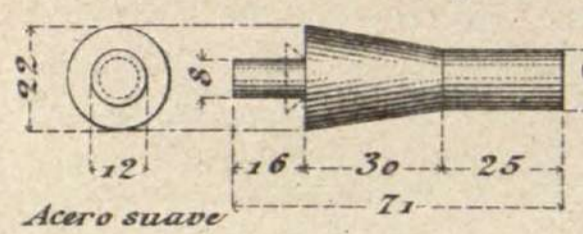

2 Sotrozos-estribos del juego delantero (E=6/10)

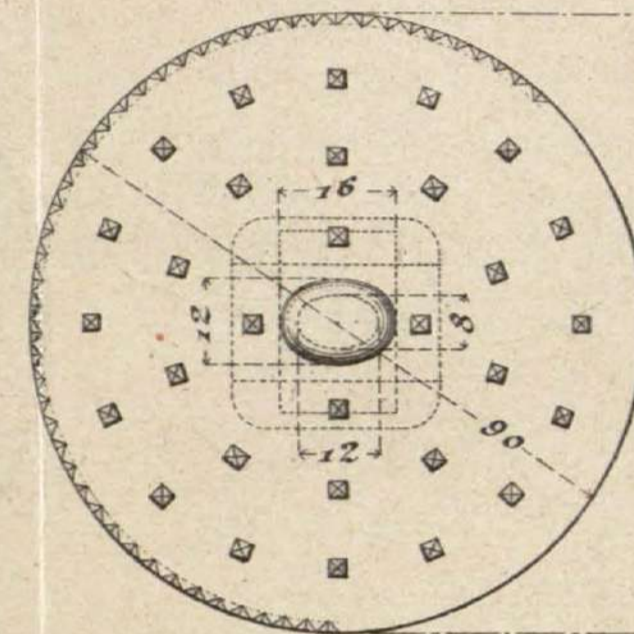

4 Grapas para sujeción de las hachas (E=5/10)

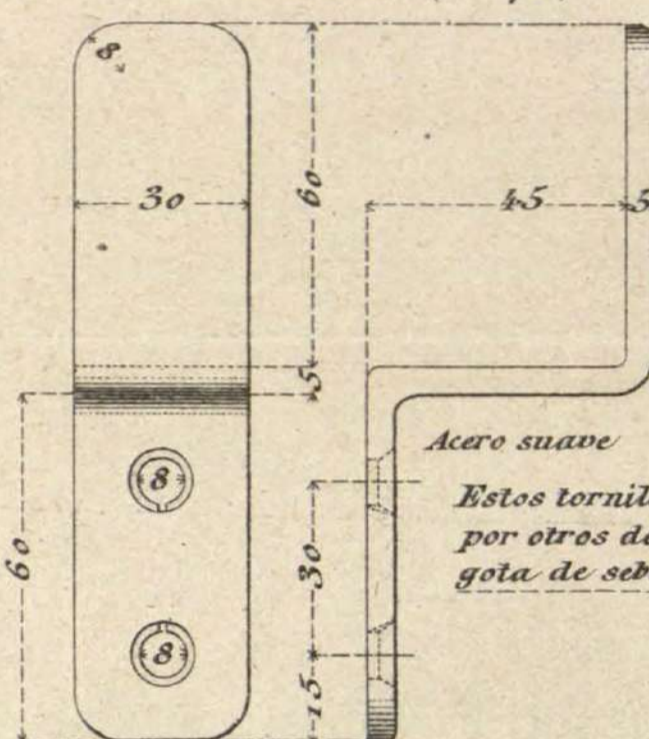

Escuadras de sujeción de las tablas de piso (E=6/10)

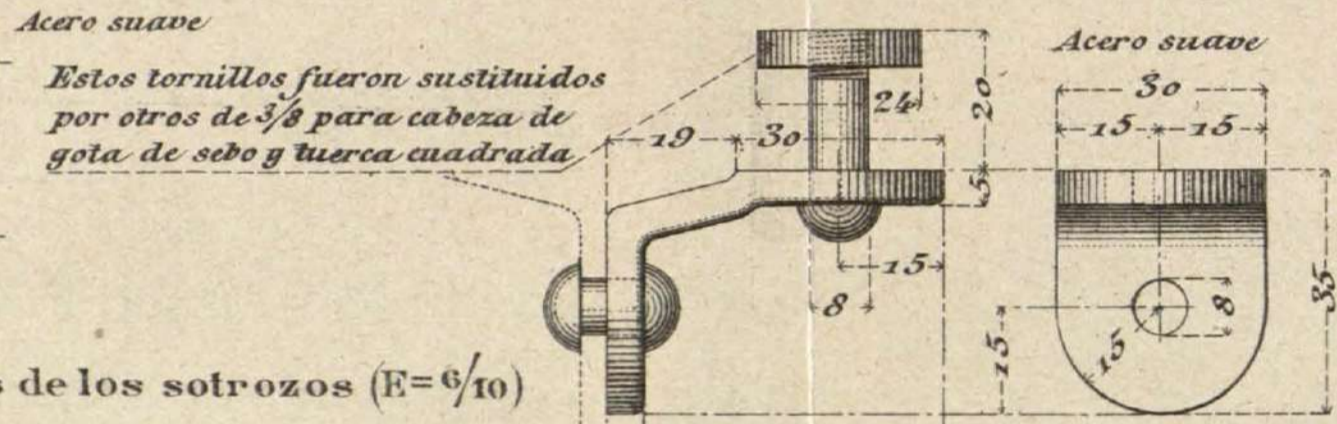

8 Grapas para zapapicos y palas (E=6/10)

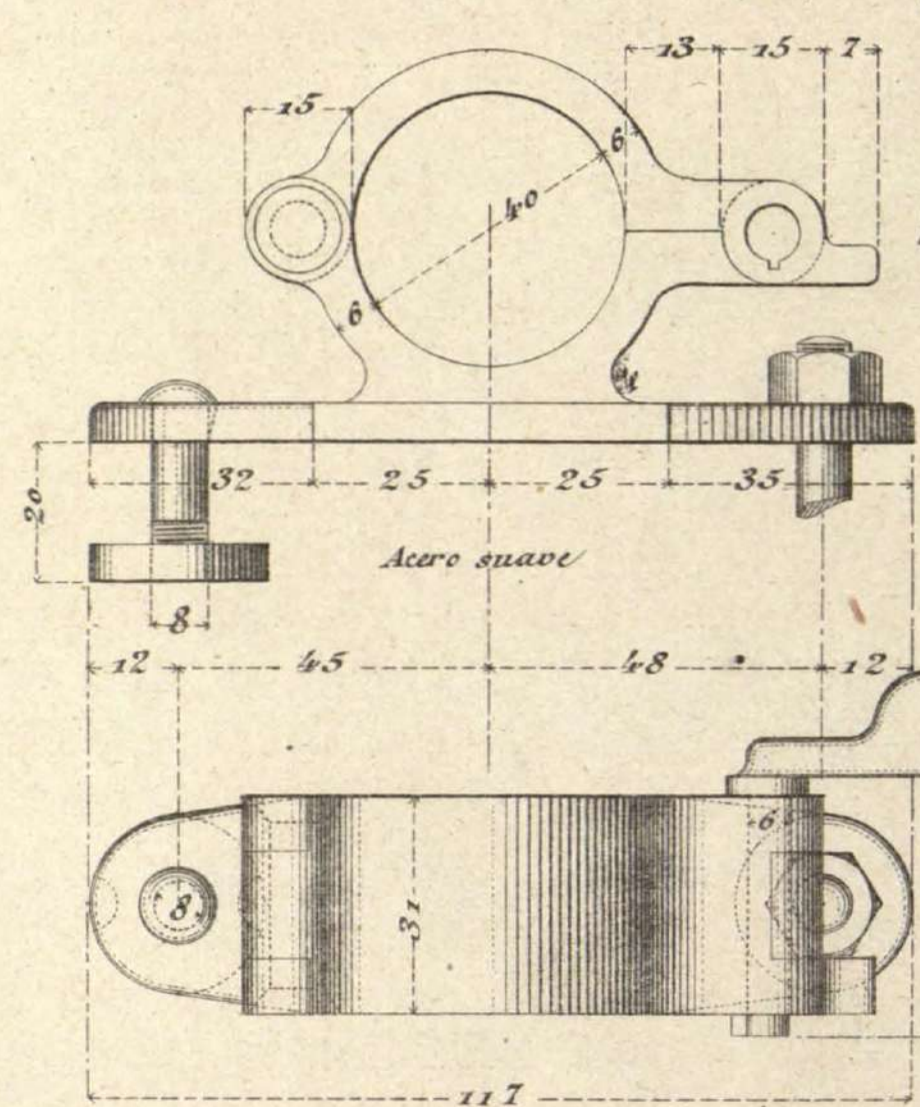

4 Ejes de las bridas de los sotrozos (E=6/10)



Grapas para francaletes (E=5/10)

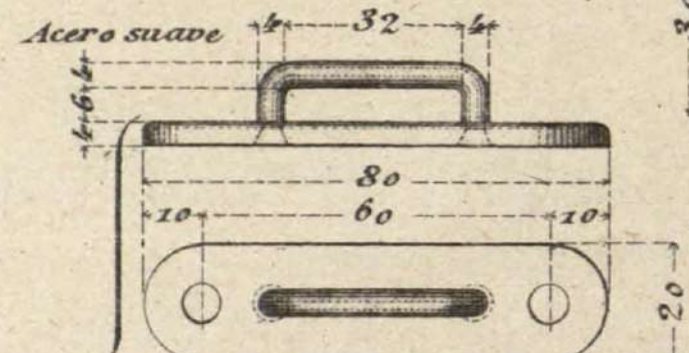

Tornillo de sujeción de las grapas (E=6/10)

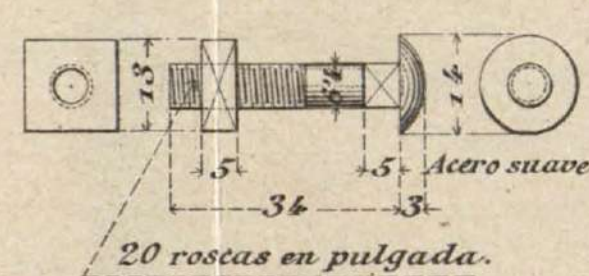

24 para el carro n.º 2.  
(8 de ellas 5 mm. mas cortas)  
32 para el carro de grupo.  
Sirven para la sujeción de palas,  
zapapicos, hachas, mazos y almohadon.

2 Bisagras de picolete del cajón del pescante (E=4/10)

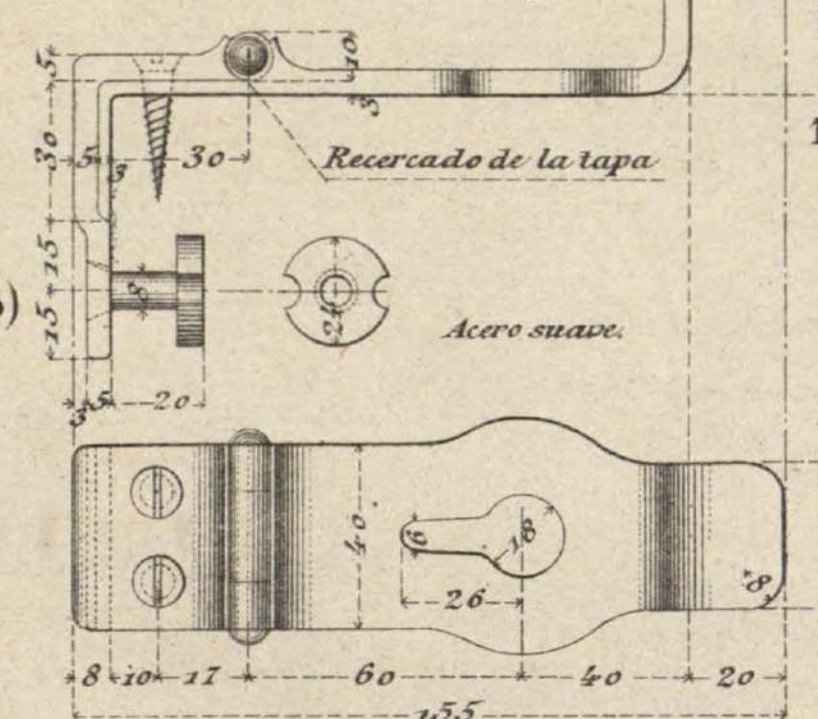

2 Picoletes del cajón del pescante (E=6/10)

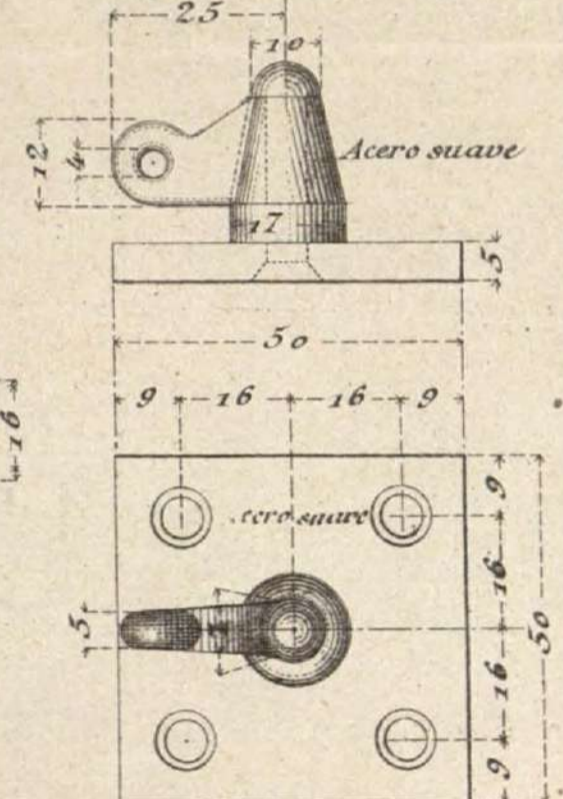

12 Grapas para francaletes de ruedas (5/10)

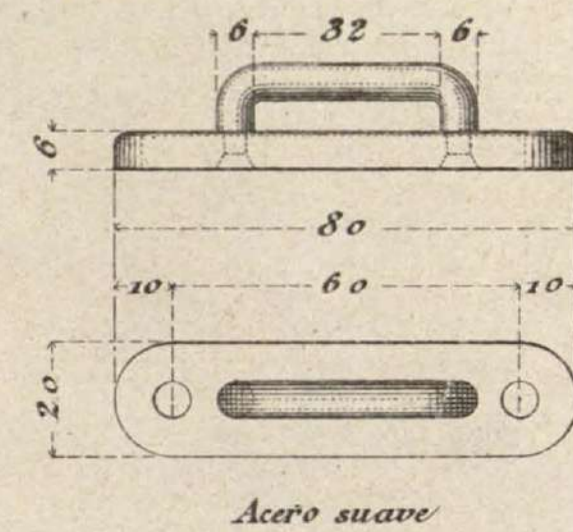

# CARRO DE BATERÍA NÚMERO 2

## DETALLES

Escala 2/10

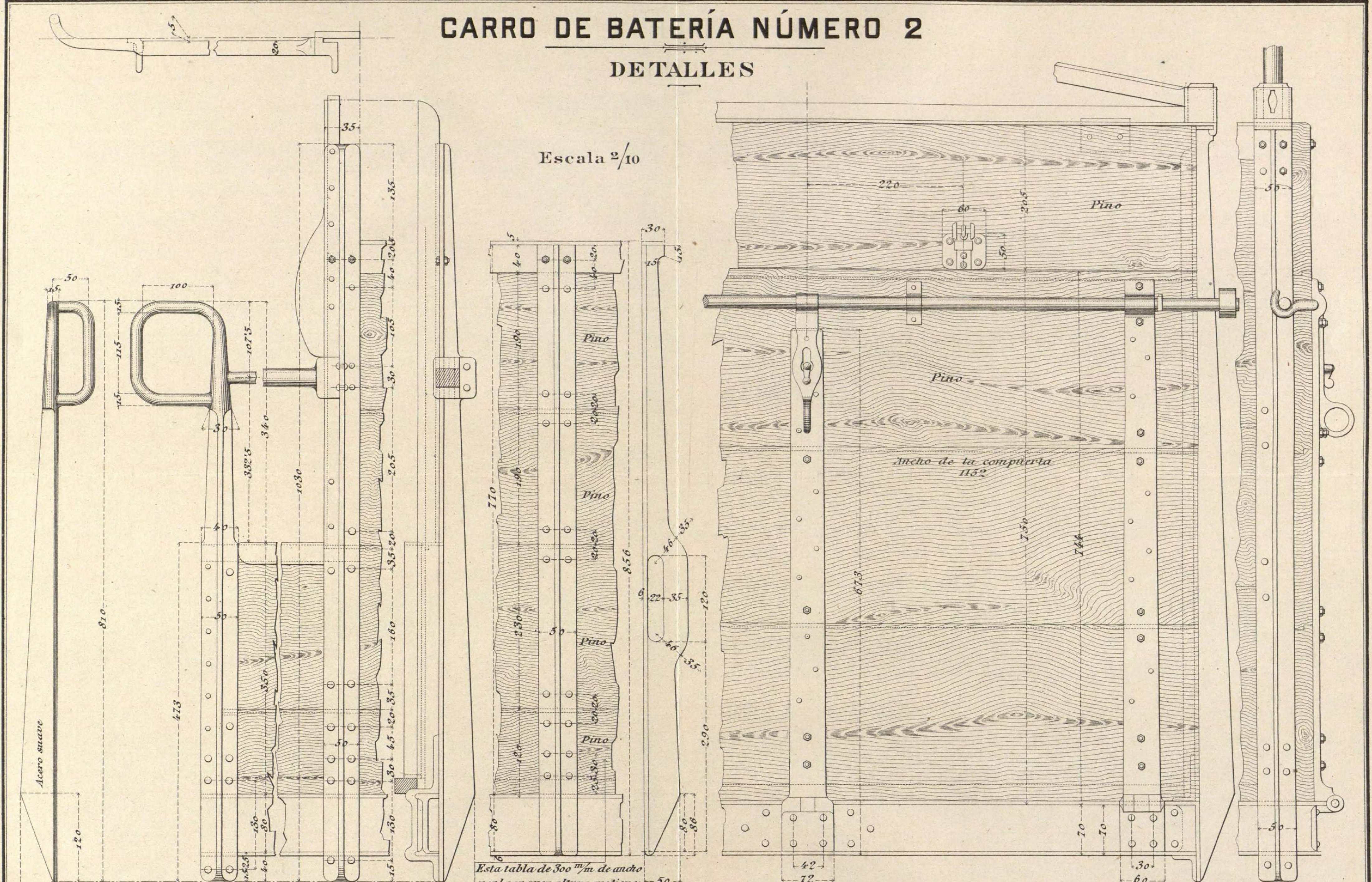

Todos los herrajes de acero suave.  
 Todos los tornillos con pasador inmediato a la tuerca.

Esta tabla de 300 m/m de ancho por la mayor altura que tiene la trasera del carro.  
 Para los 5 pilarillos situados entre los dos soportes de ruedas de respetos.

La compuerta, igual a la del carro n.º 1 con las solas diferencias del mayor ancho y de la forma de la parte inferior de las bisagras que tienen que ajustarse al perfil de la vigueta de que se forma el lecho. Estas se sujetan con los mismos remaches que las escuadras de unión del cabecero a brancales y vigueta central.

# CARRO DE BATERÍA NÚMERO 2

I Caja para viveres de tropa (E=2/10) *Distribución interior*

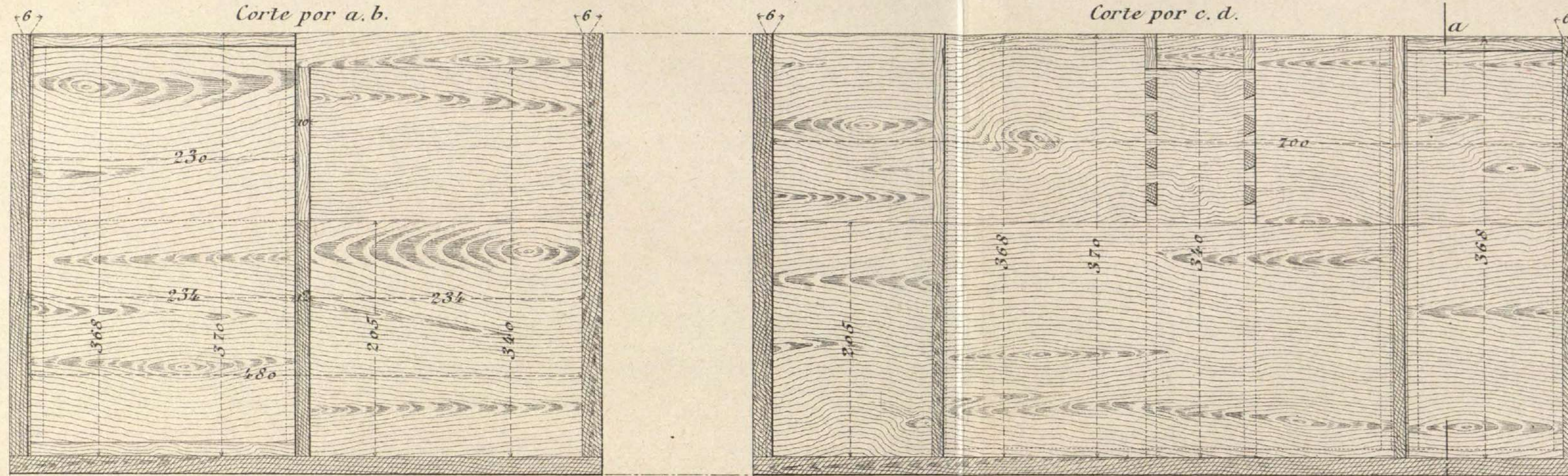

I Caja (E=2/10)

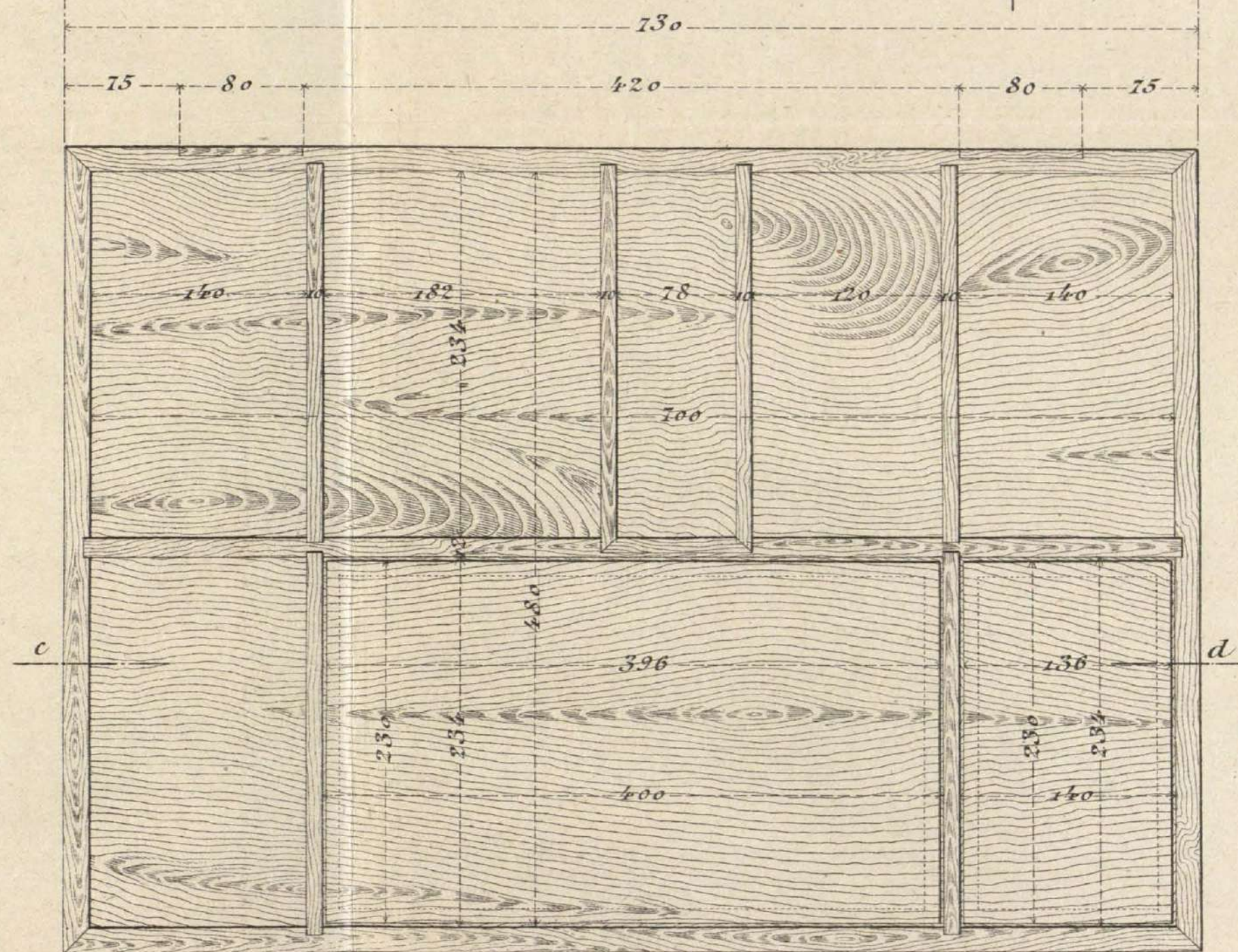
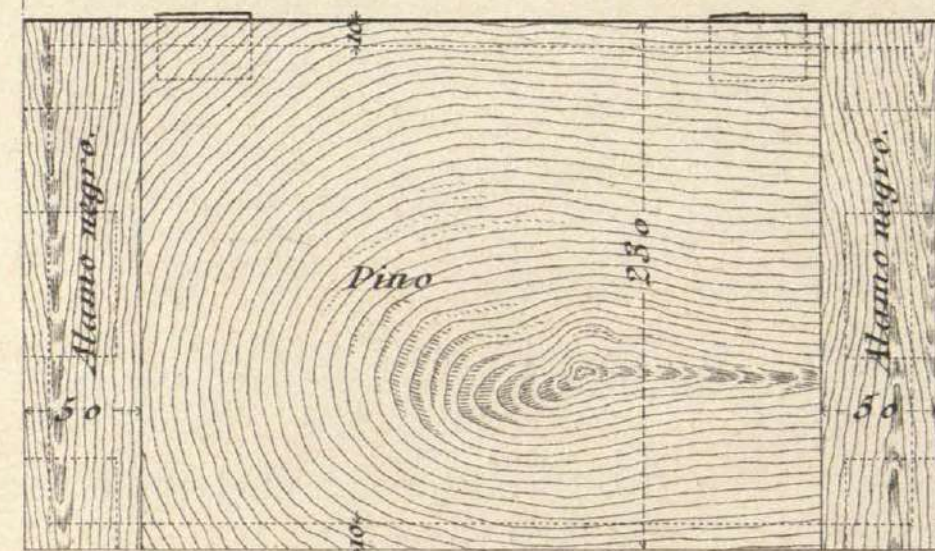
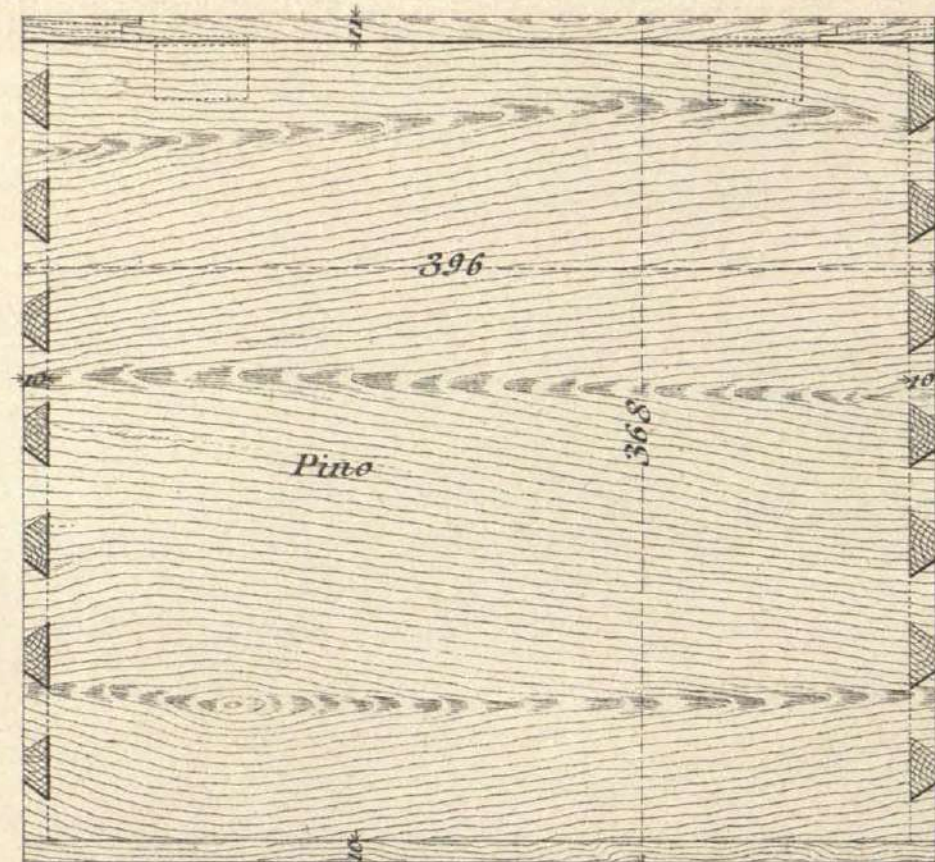

I Caja (E=2/10)

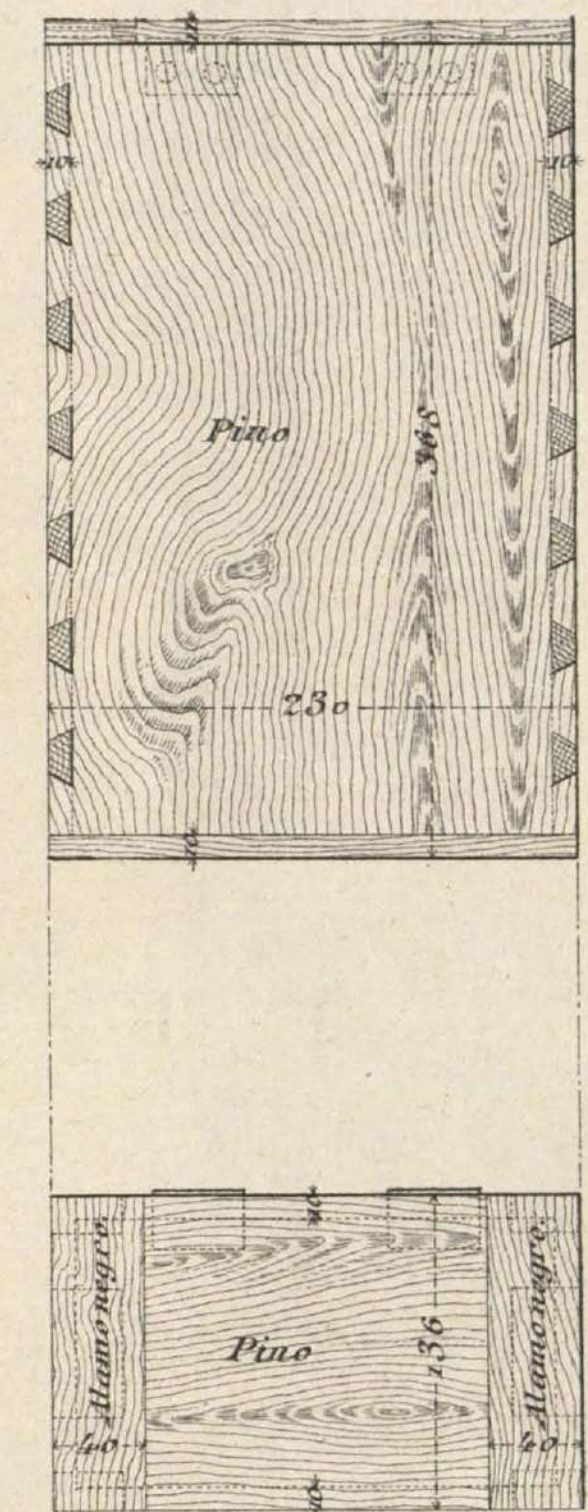





# CARRO DE GRUPO HERRAMIENTAS DE FORJADOR

Escala 4/10

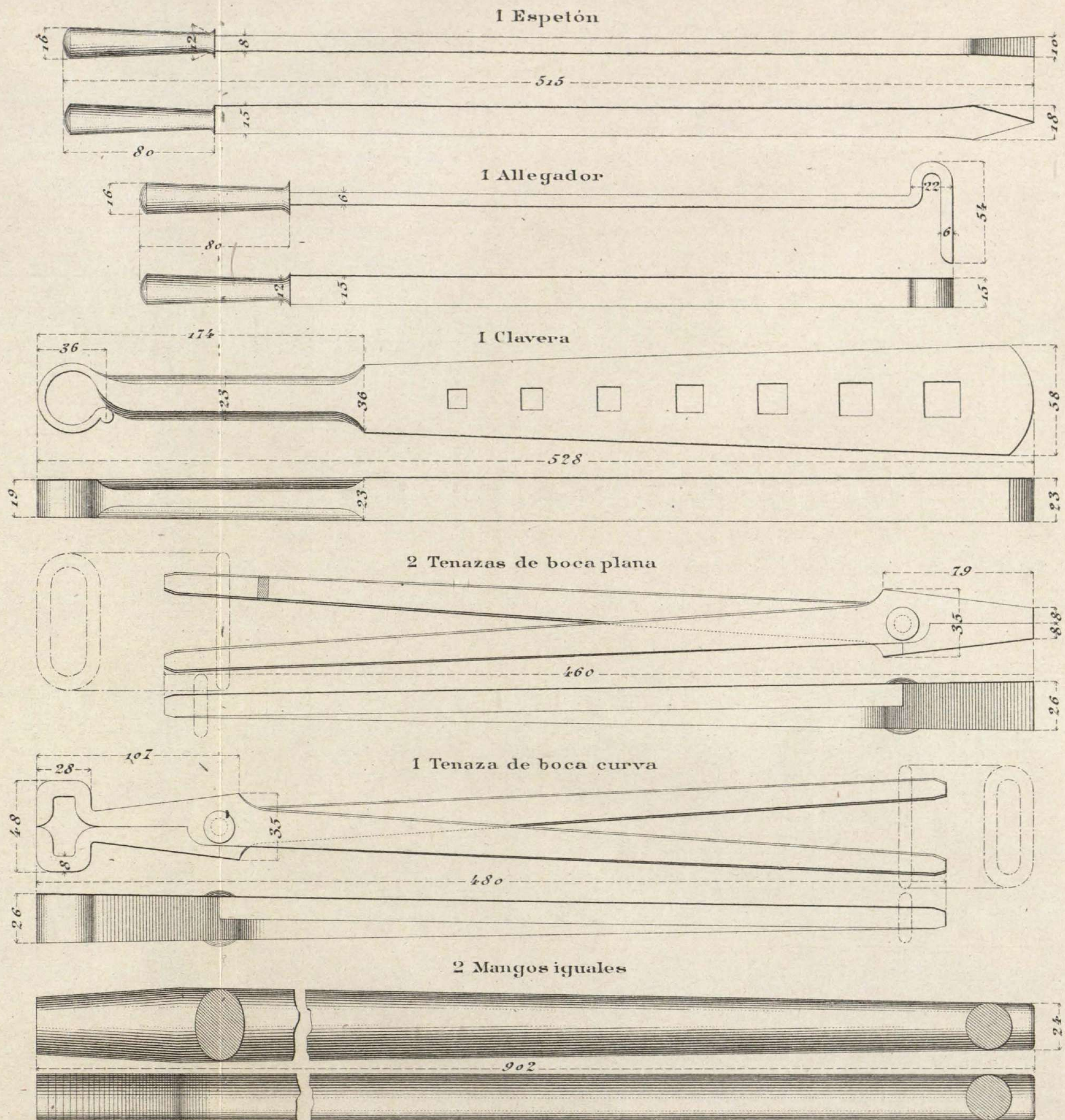
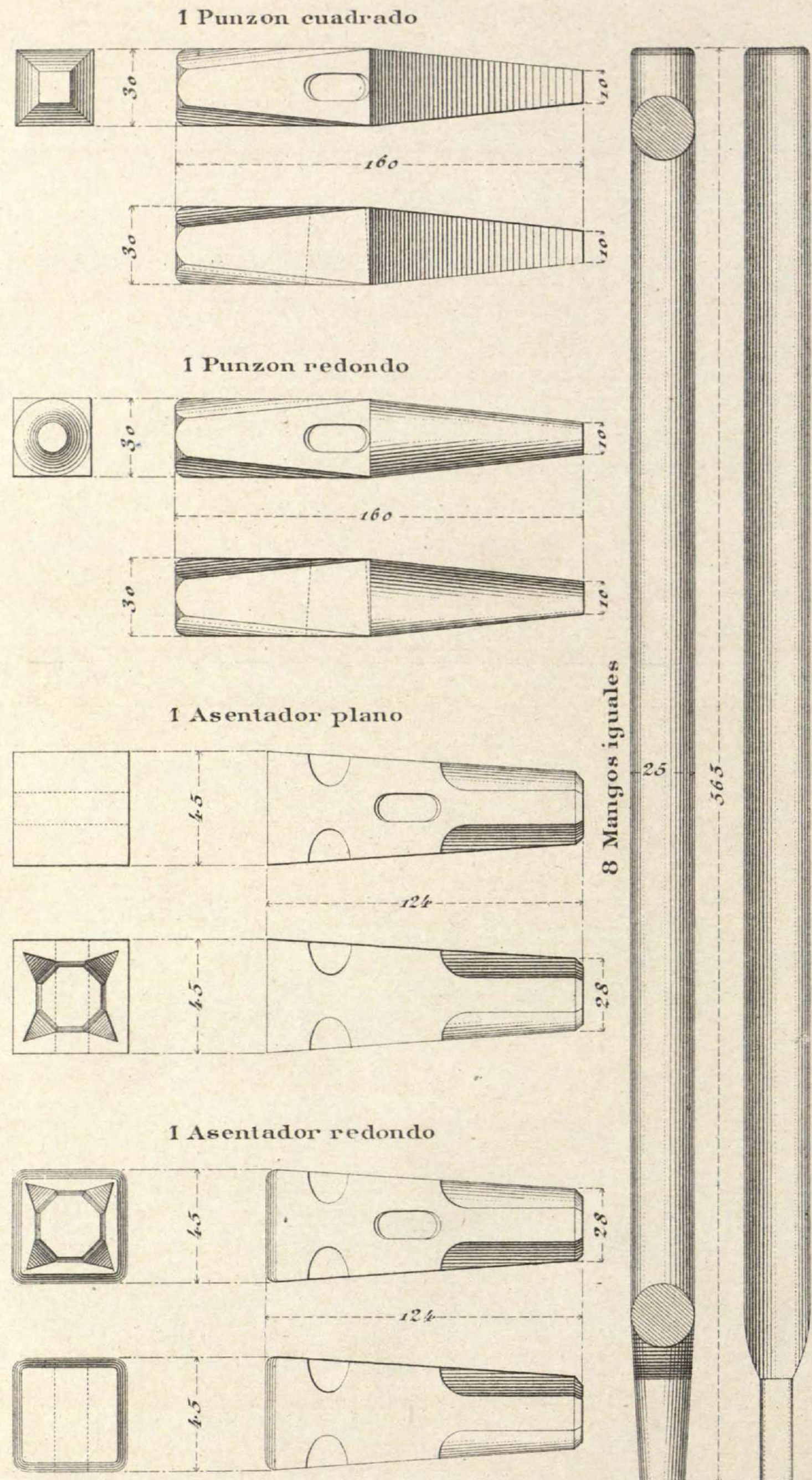

# CARRO DE GRUPO

## HERRAMIENTAS DE FORJADOR

1 Compás recto.

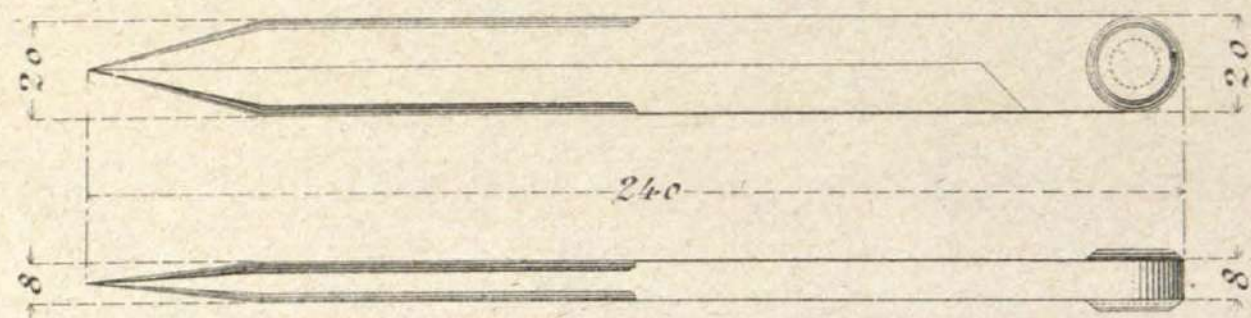

1 Martillo de forjador.

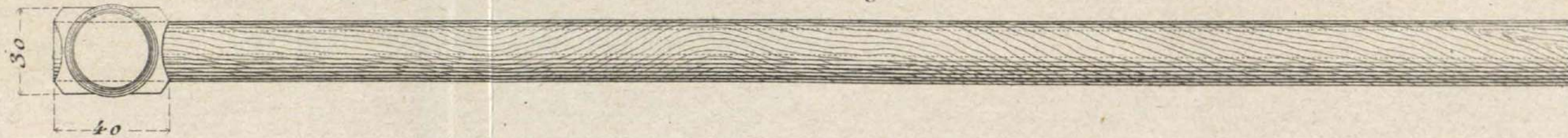

Escala. 4/10

1 Tajadera

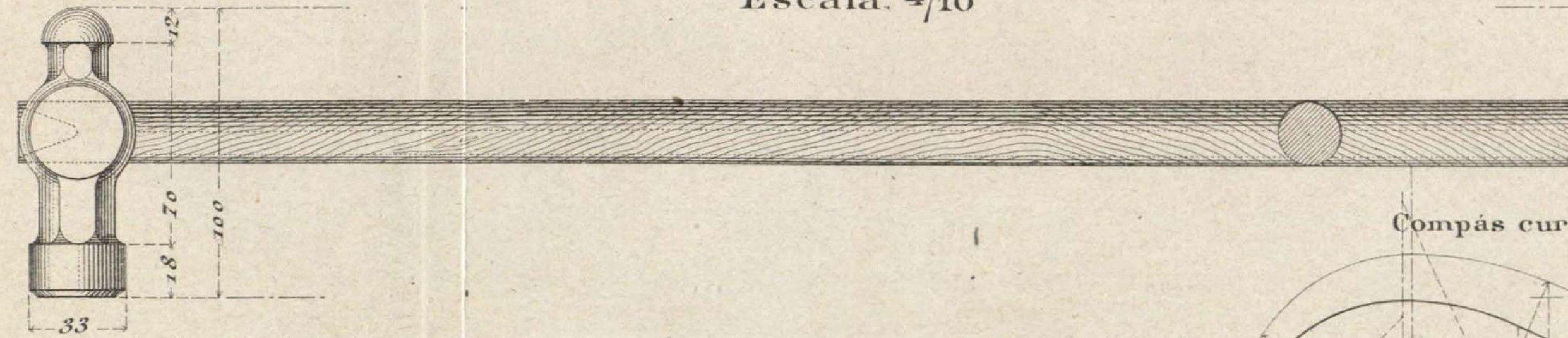
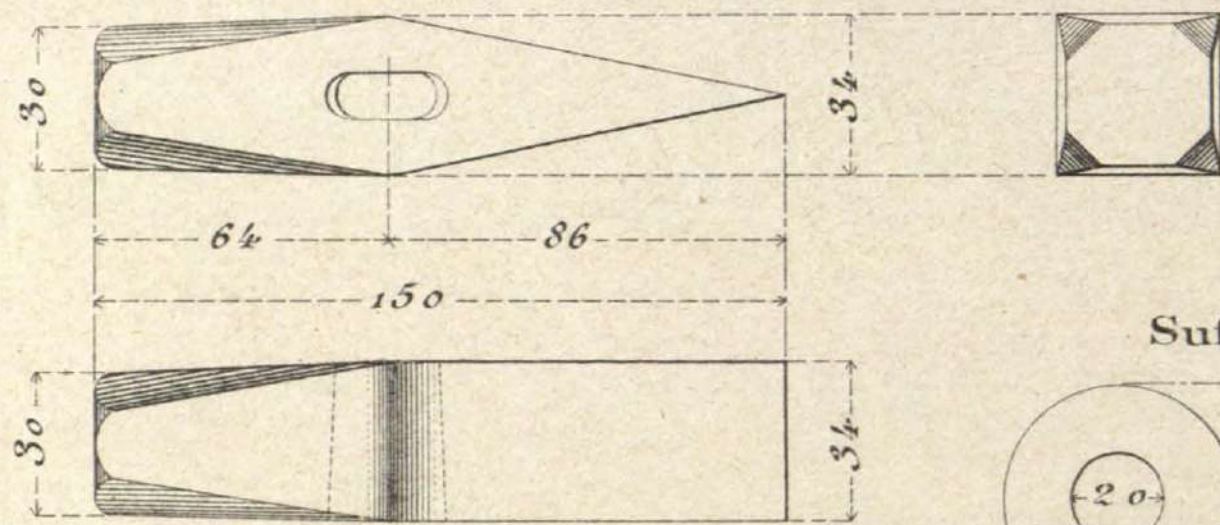

Compás curvo



Sufridera.

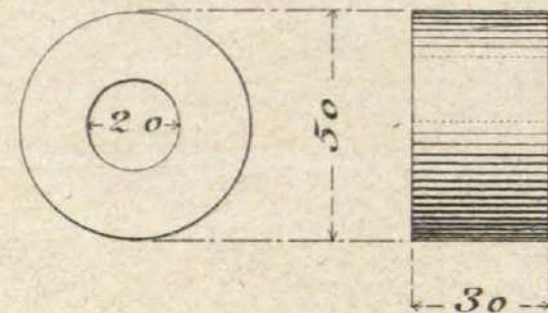

1 Pala

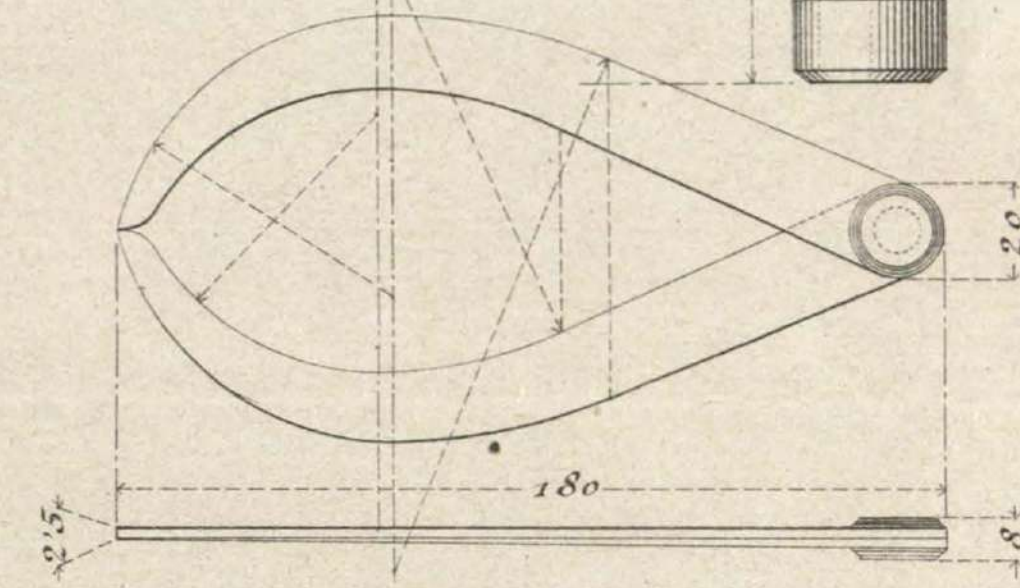

2 Machos

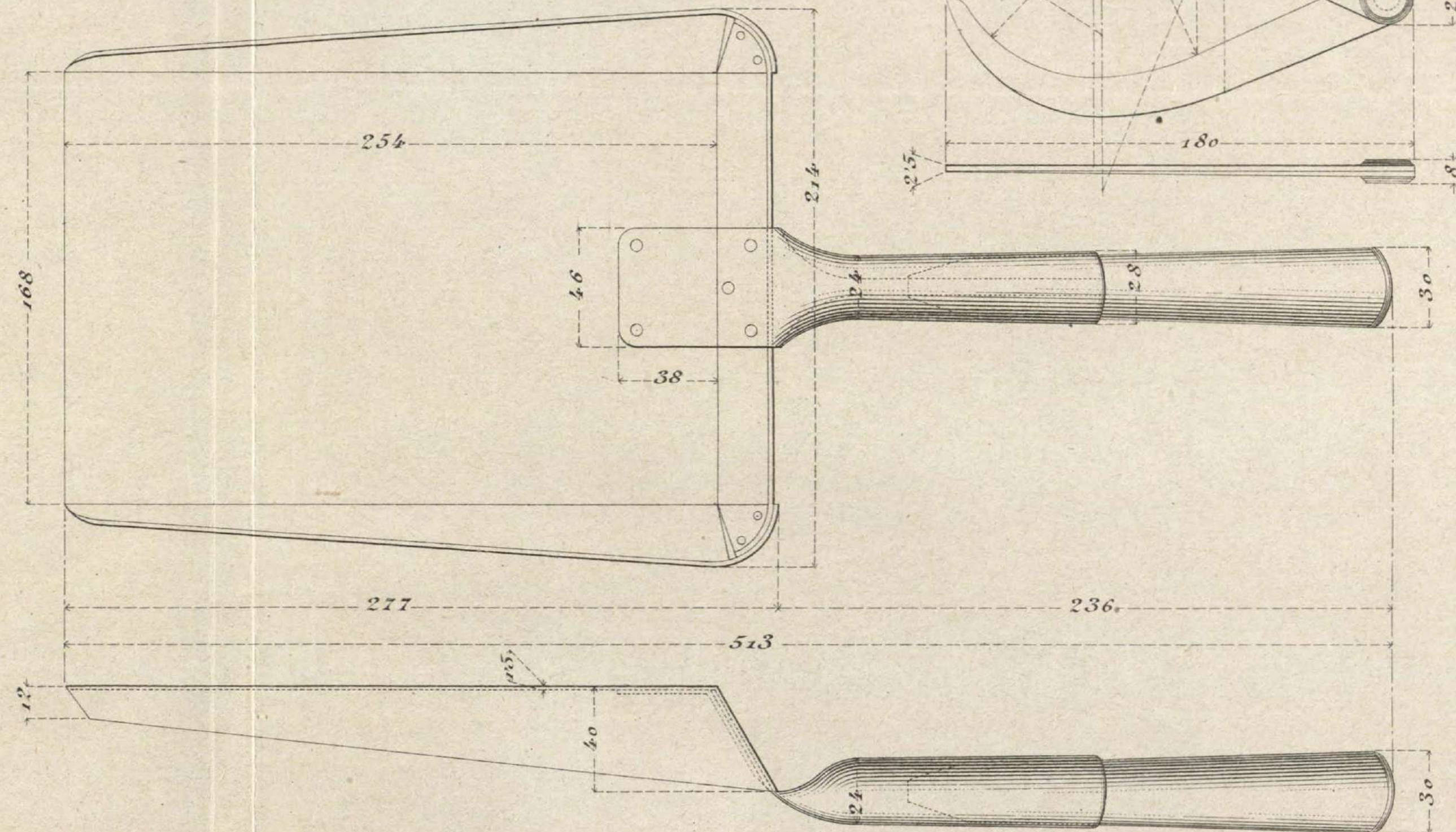
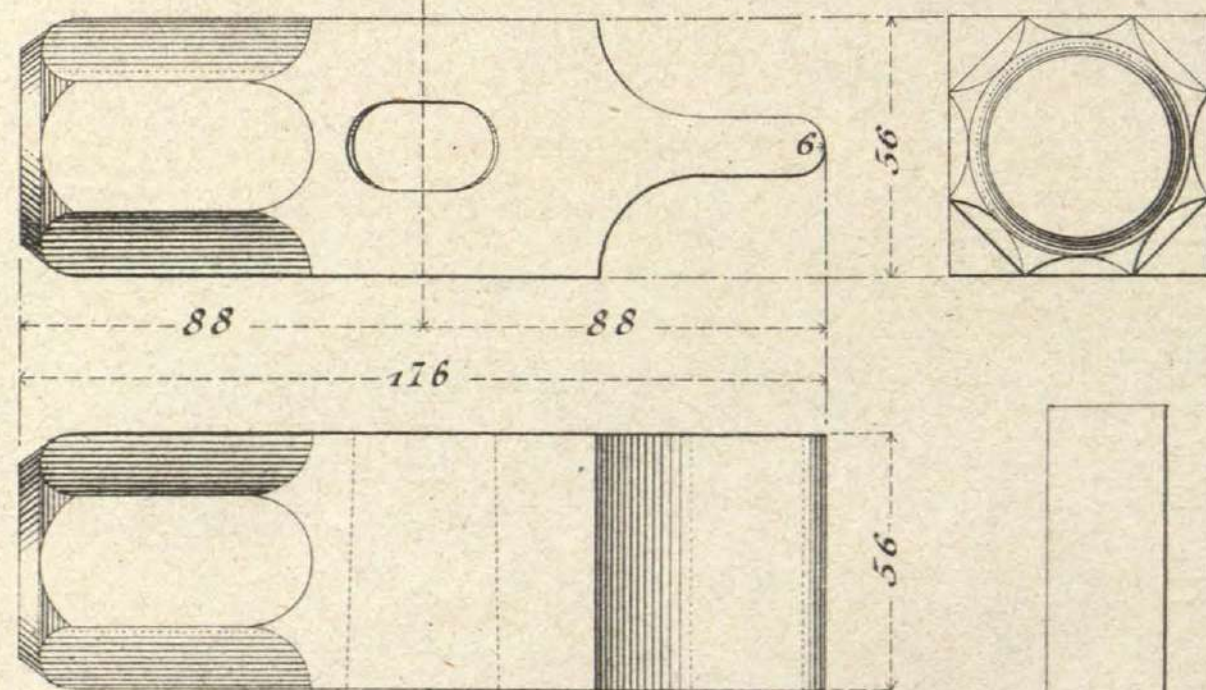

1 Escuadra de hierro

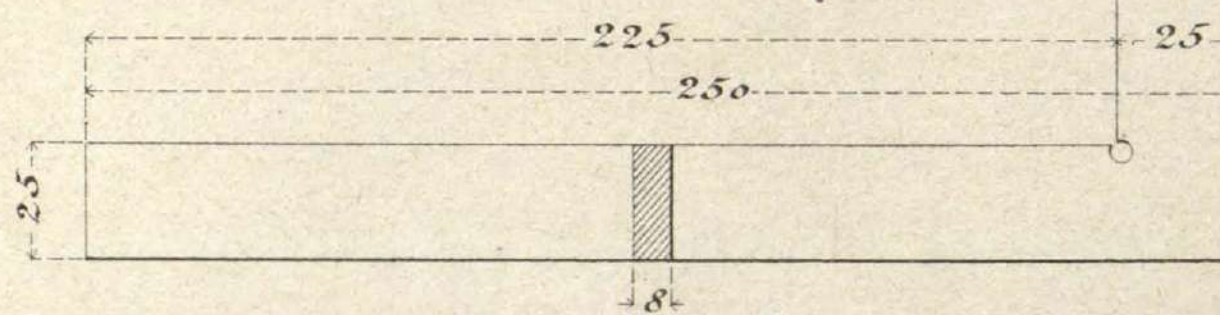

# CARRO DE GRUPO

2 Cajas de equipaje de Jefe (1/5)

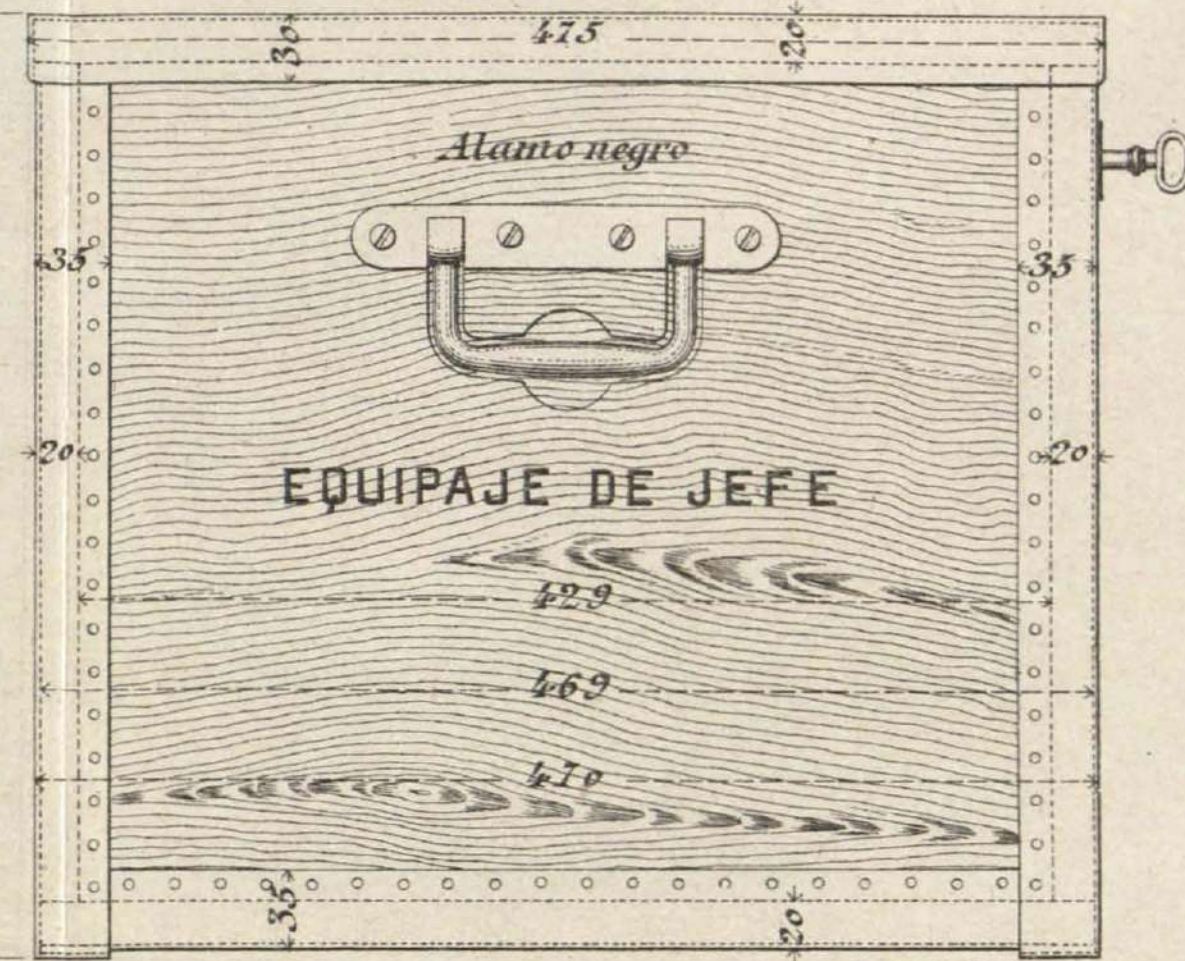
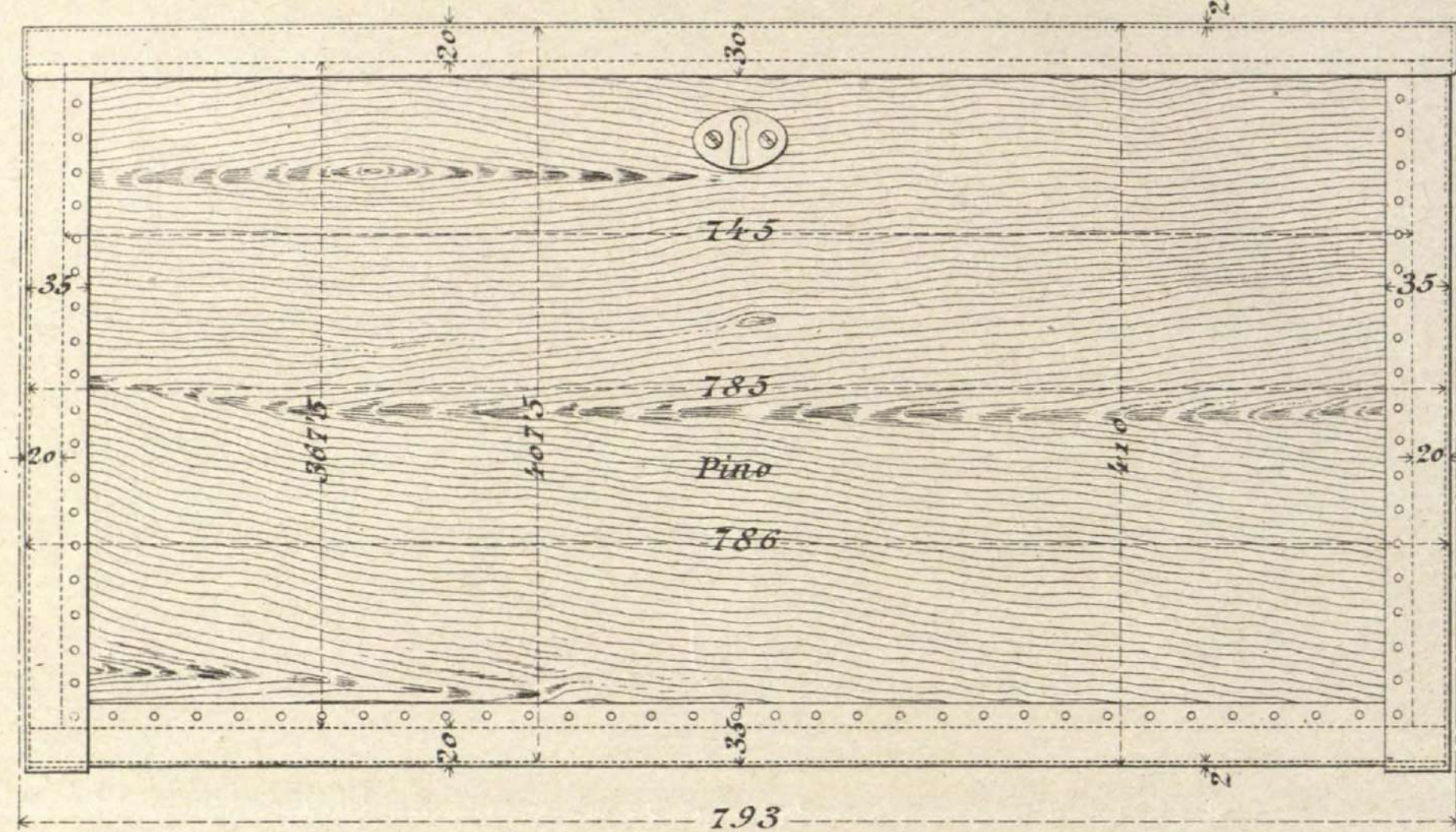

6 Remaches (1/1)  
Para sujetar las bisagras al cuerpo de la caja.

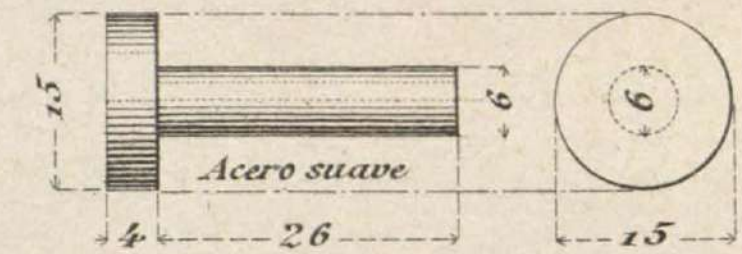

6 Tornillos (1/1)  
Para rosca de madera (Tapa)

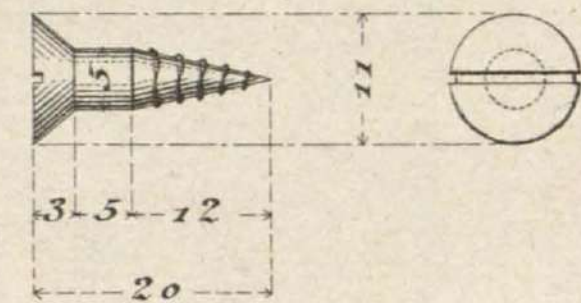

Toda la caja forrada interiormente, lo mismo que la batea de lona (rayadillo azul y blanco)

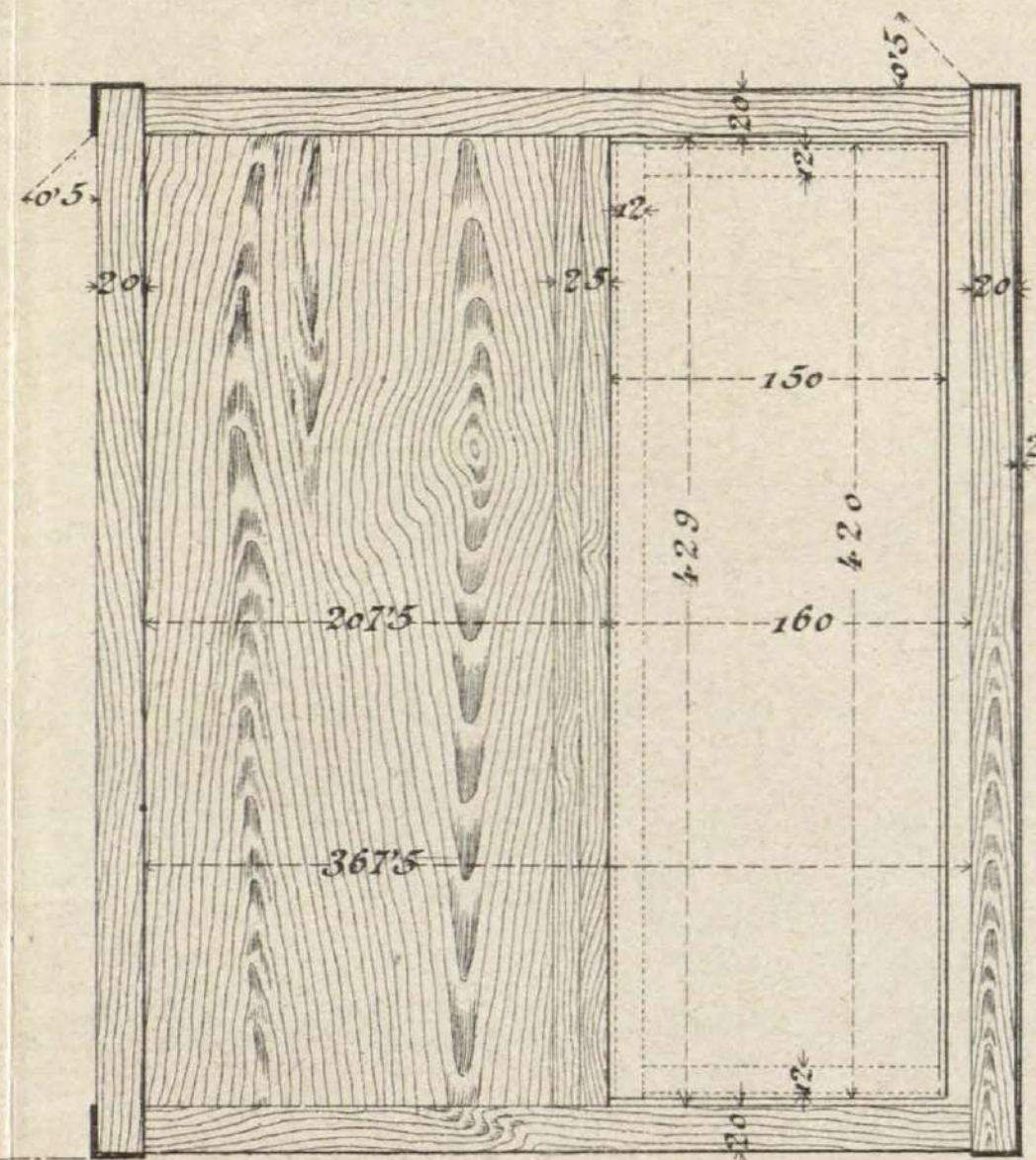
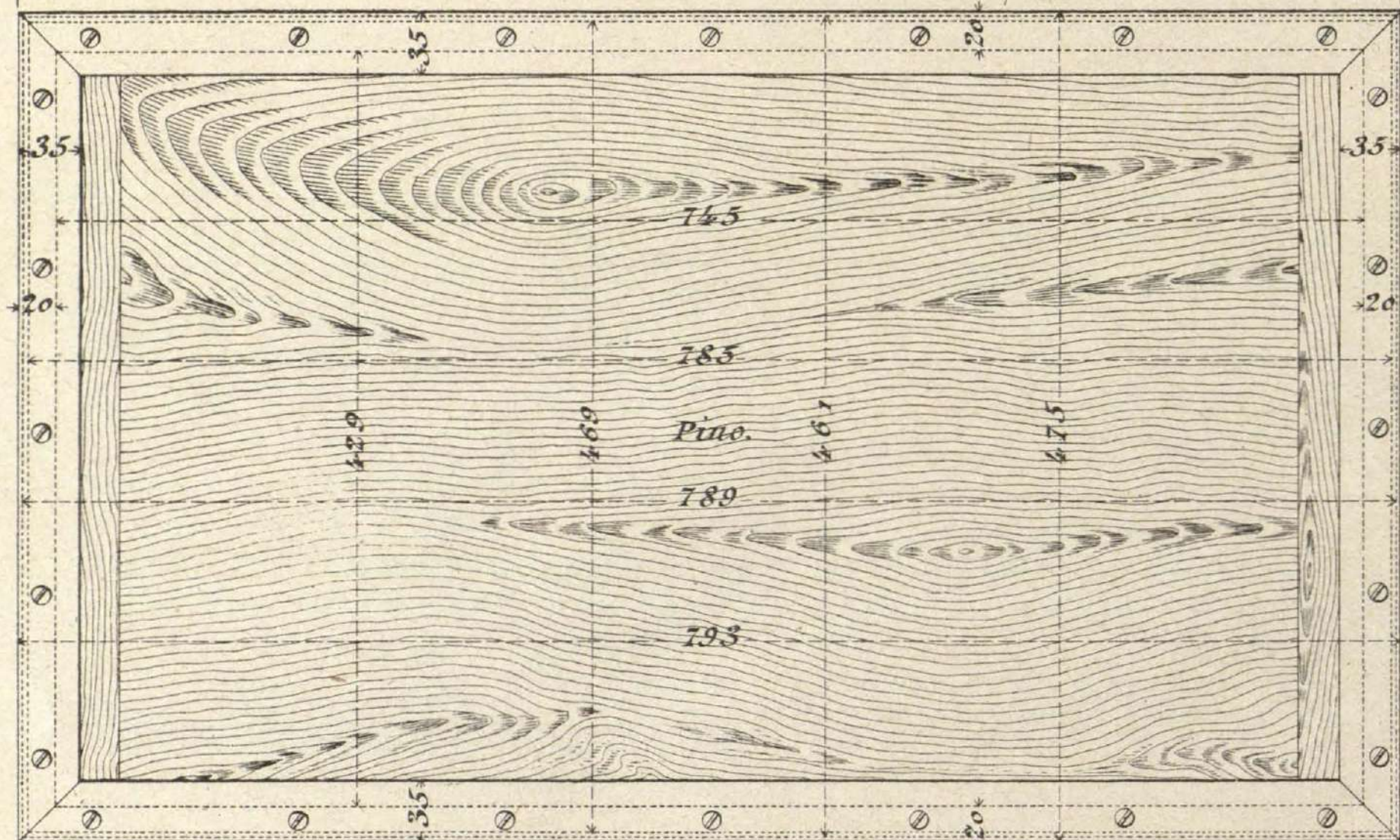

Cantenera (1/1)

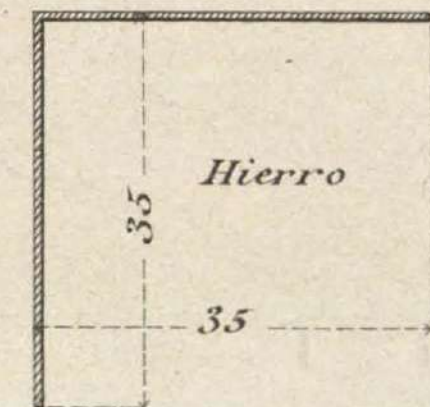

Recercado (1/1)

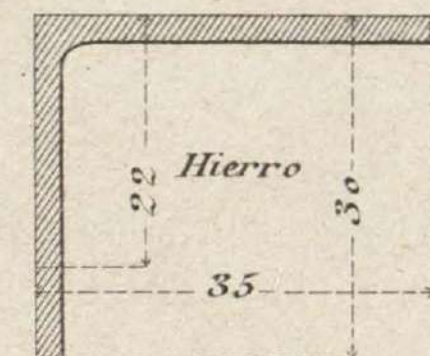

# MORTERO Bc. 21 cm. MOD. 1895.

CARGAS DE PROYECCIÓN DE PÓL. TUB. Nº 1 BIS. FIL. 35 a. PESO DE UN HAZ 155 GRAMOS.

Escala  $\frac{3}{10}$ .

1ª Carga=1240 Kgs. en 8 haces. (2 Lechos.) 2ª Carga 1,085 Kgs. en 7 haces (2 Lechos.) 3ª Carga=0,930 Kgs. en 6 haces. (2 Lechos.) 4ª Carga=0,620 Kgs. en 4 haces. (1 Lecho.) 5ª Carga 0,510 Kgs. en 3 haces y 45 gramos. (1 Lecho.)

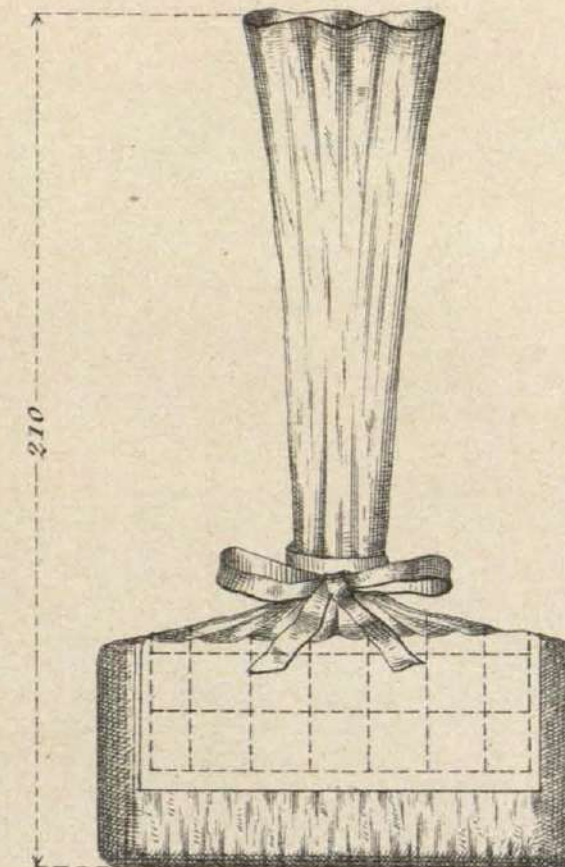
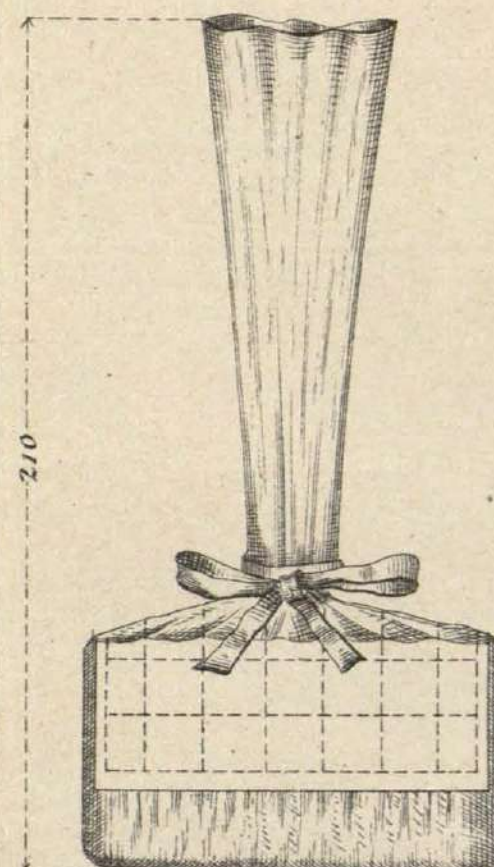
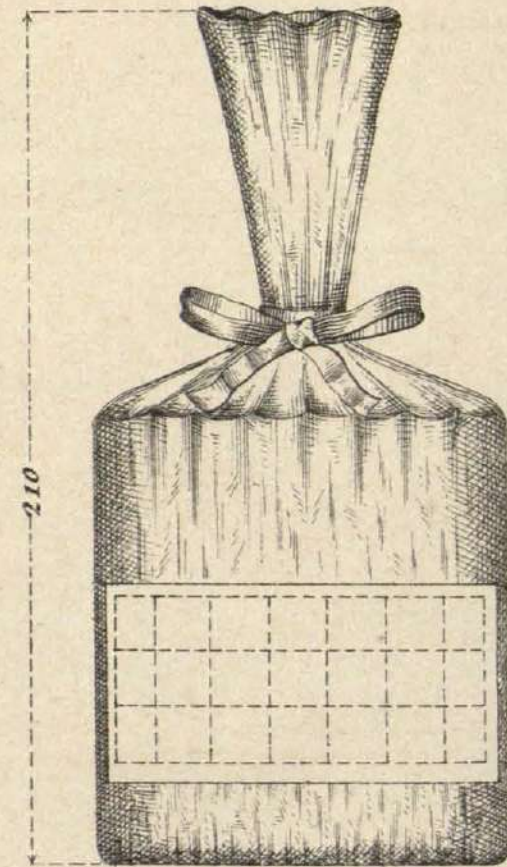
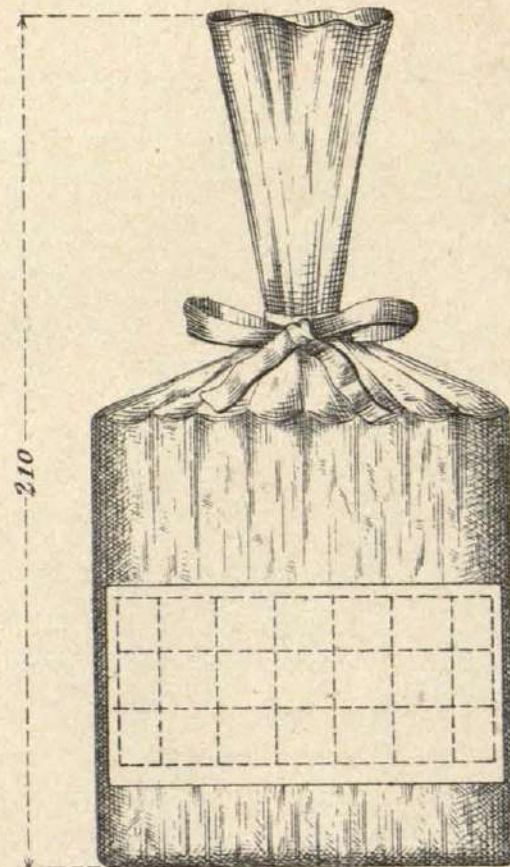
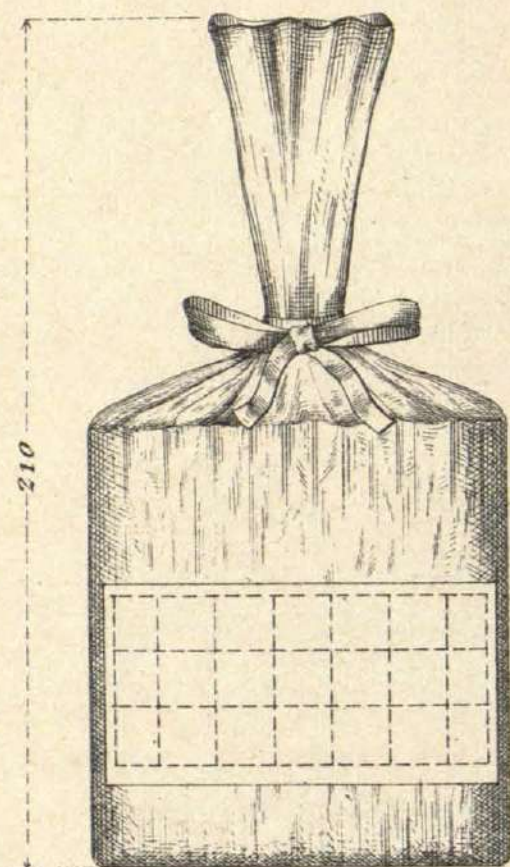
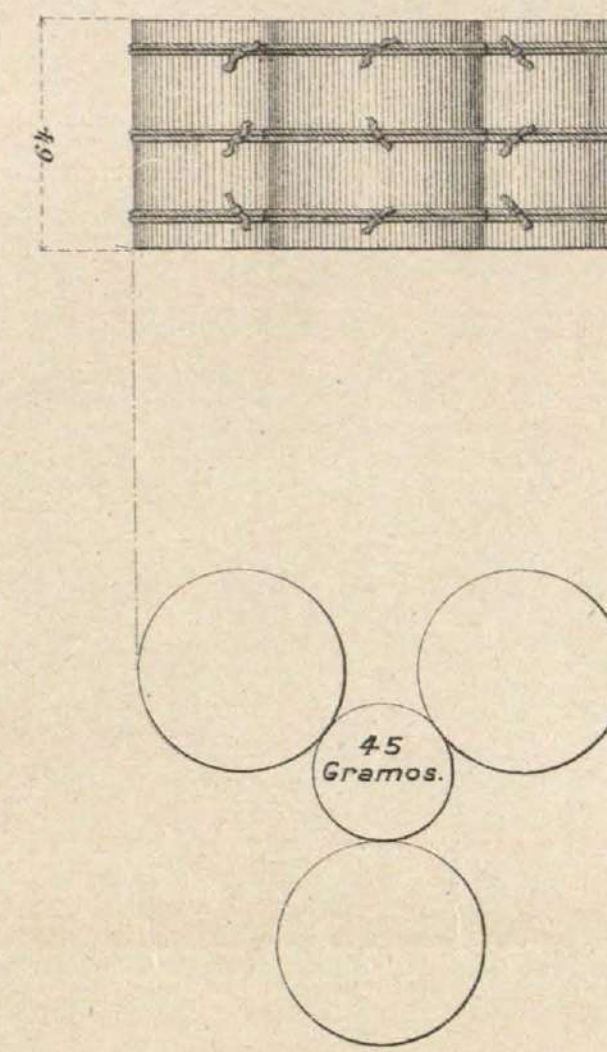
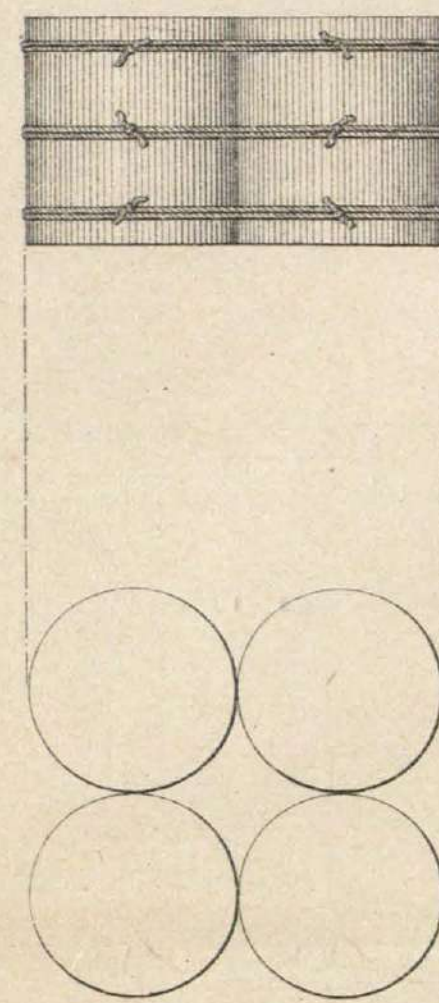
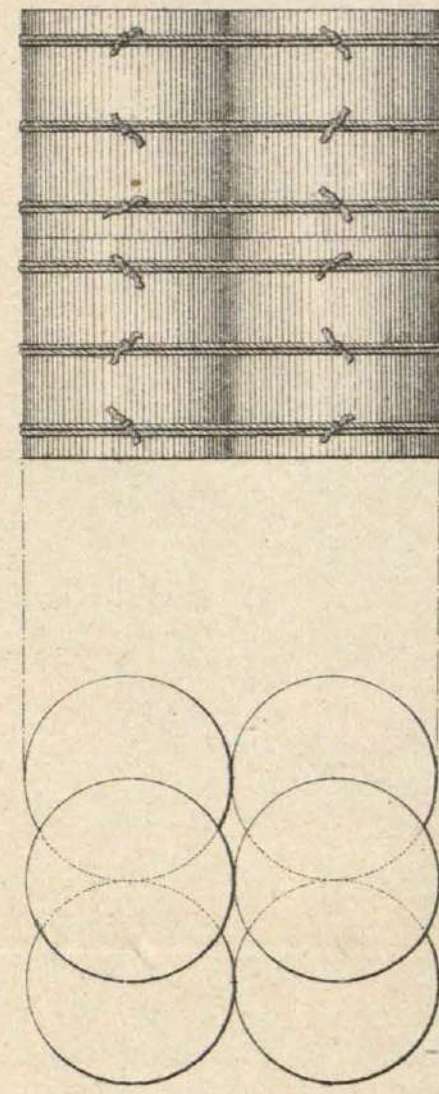
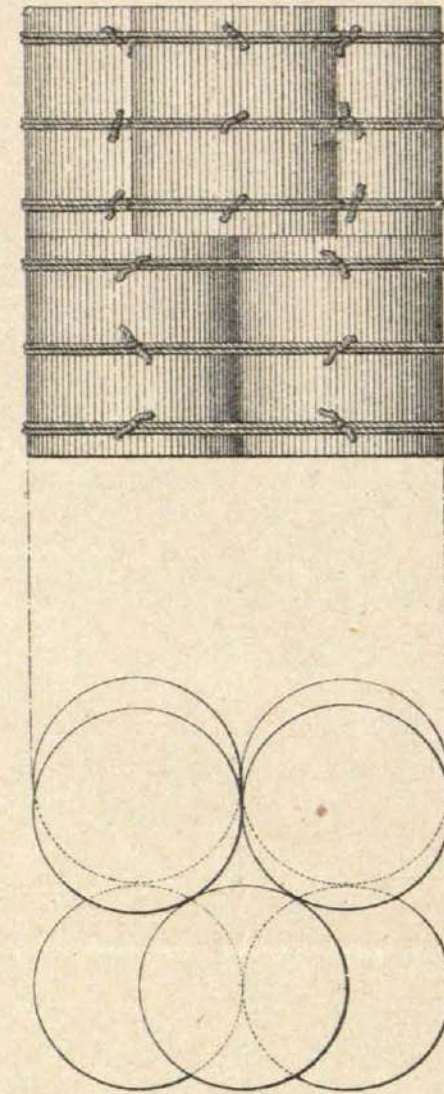
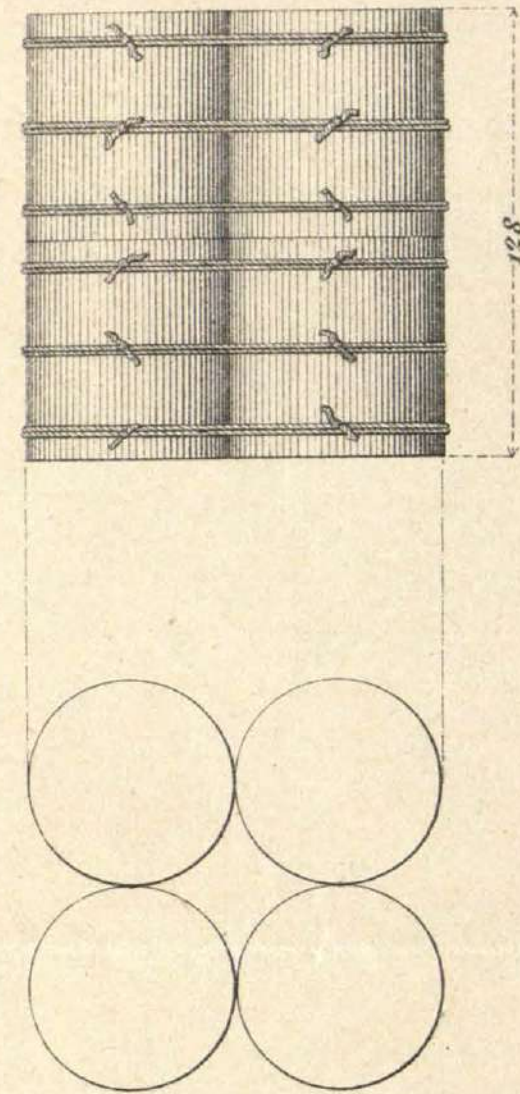
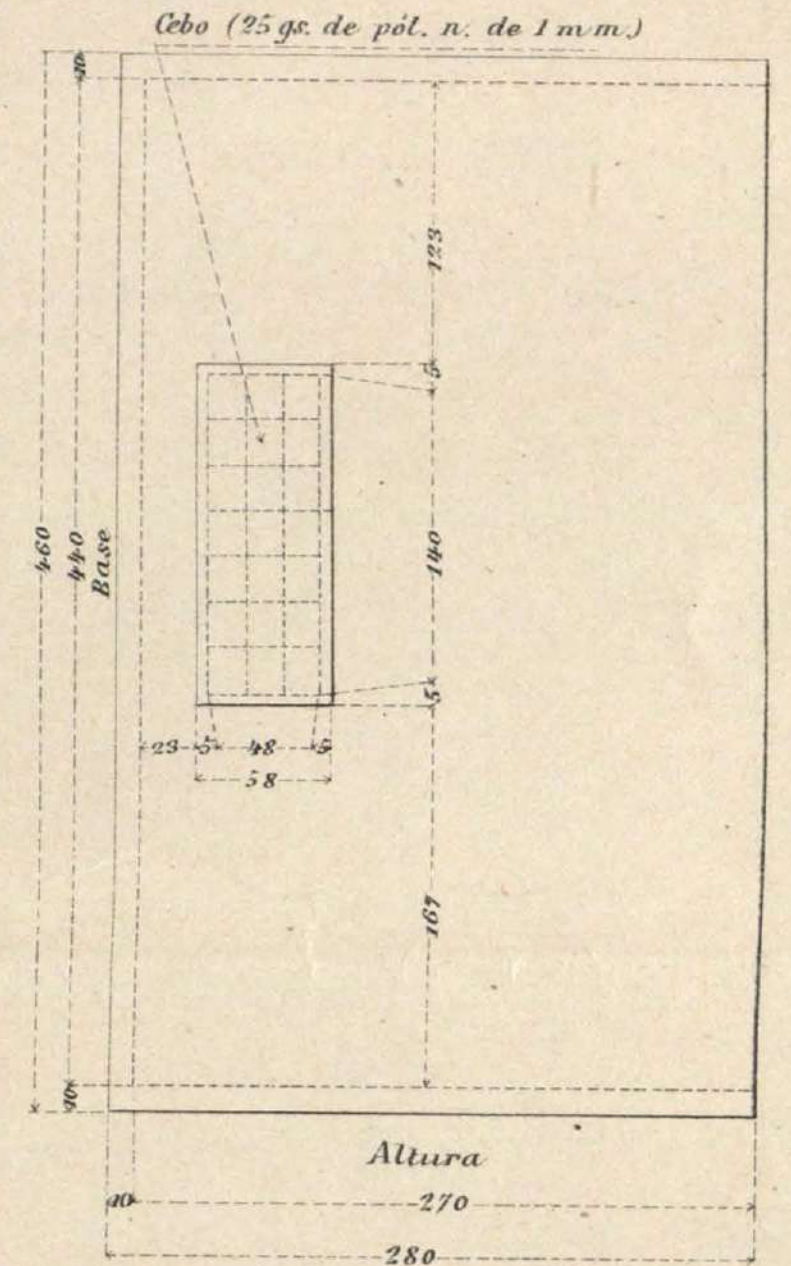

Culote del saquete. (E. =  $\frac{1}{5}$ .)

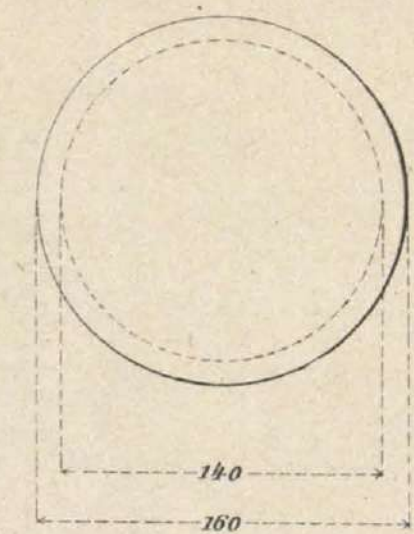

El cebo está puesto entre dos telas de filosedá, cosidas como se expresa.

# OBUS Bc. 15 cm. Md. 1891.

## CARTUCHOS Y CARGAS DE PROYECCION CON POL. TUB. N° 1 BIS

Carga 1,1625 Kg.  
7½ haces. 1ª Tabla.

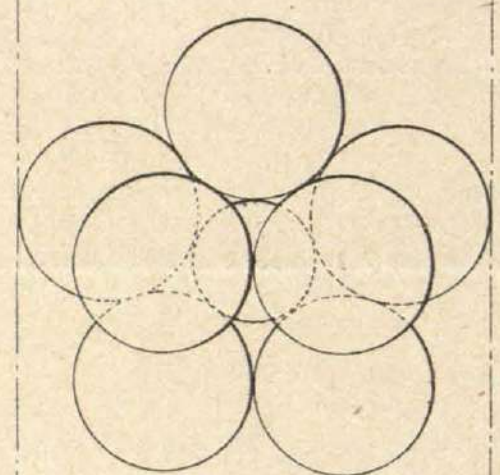
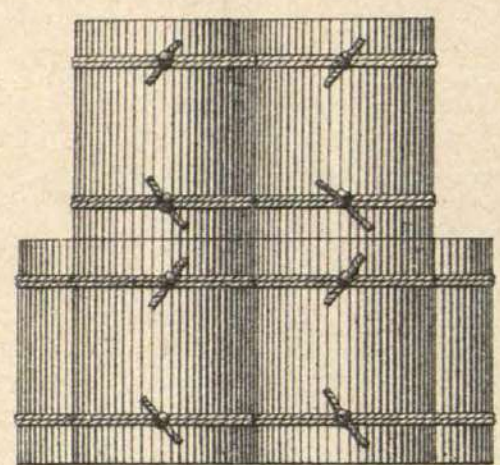

139

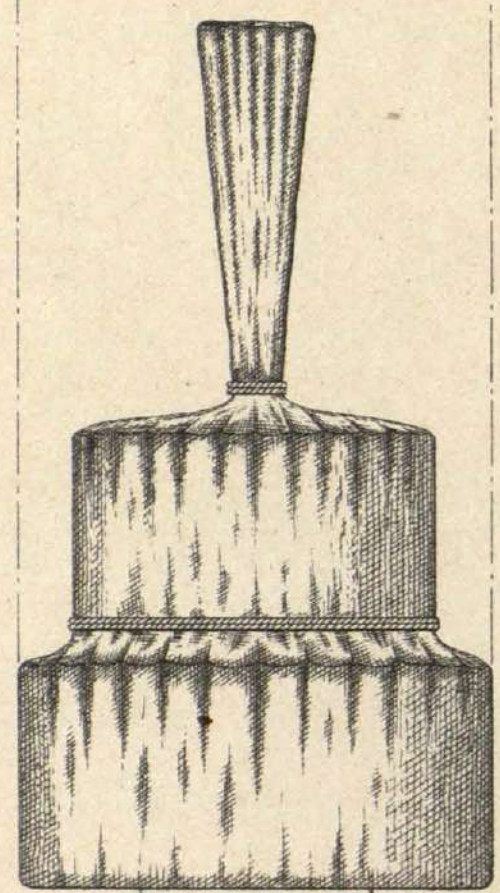

Carga 1,0075 Kg.  
6½ haces. 2ª Tabla.

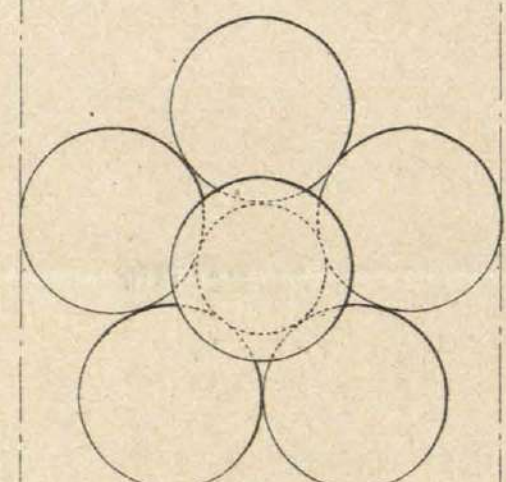
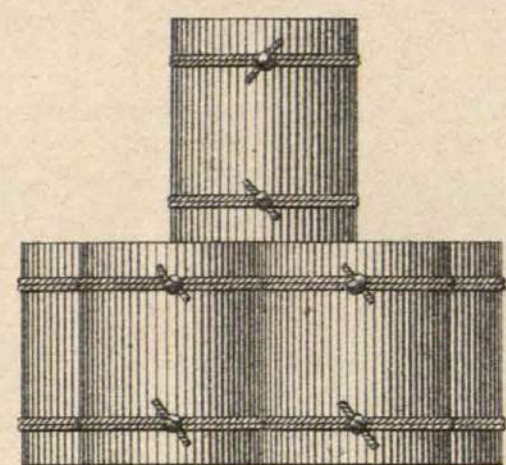

139

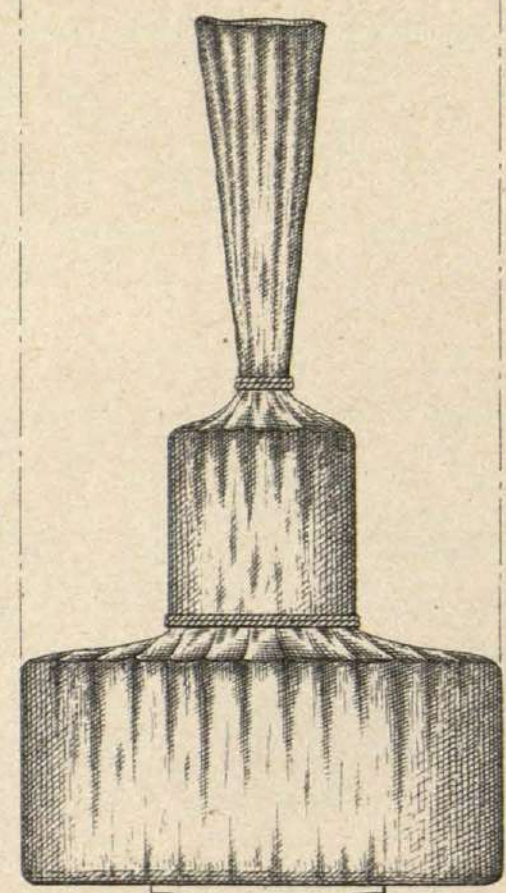

Escala 3/10

Carga 0,6975 Kg.  
4½ haces. 4ª Tabla.

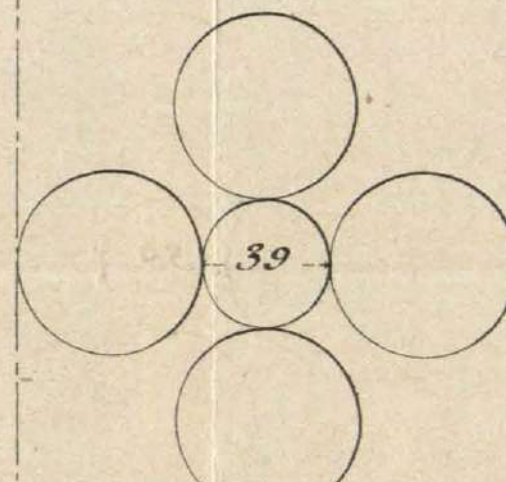
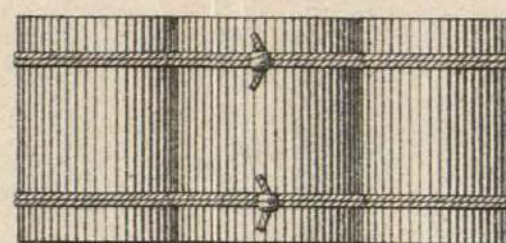

146

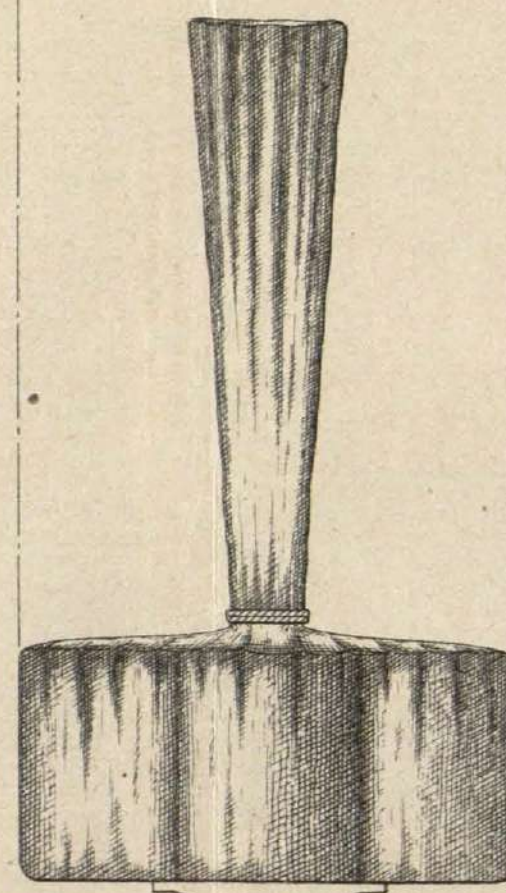

Carga 0,8525 Kg.  
5½ haces. 3ª Tabla.

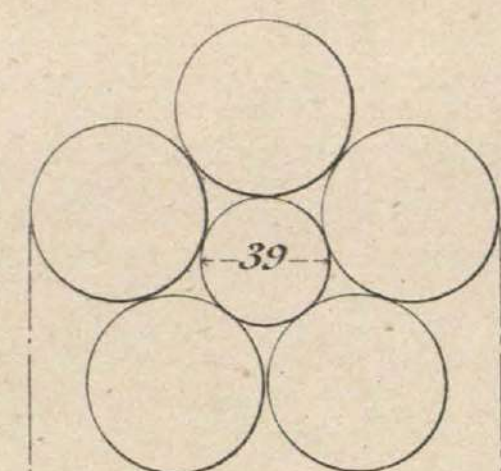

138

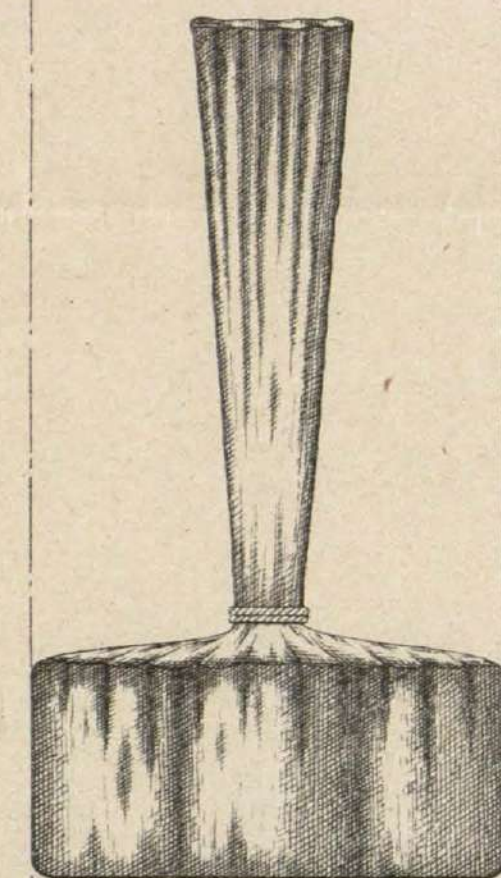

(Cabo de pólvora negra de 1 m. m.  
(10 gramos))

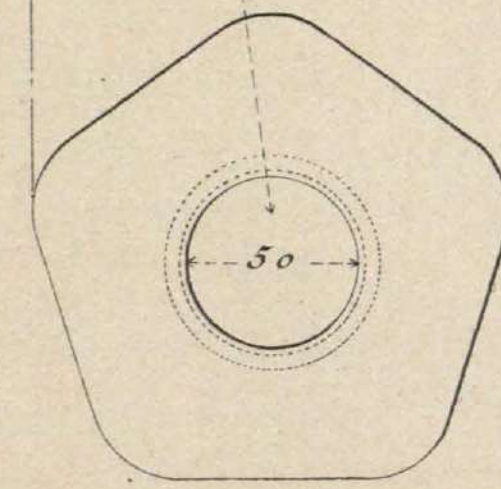

Haz de pólvora. (1/1)

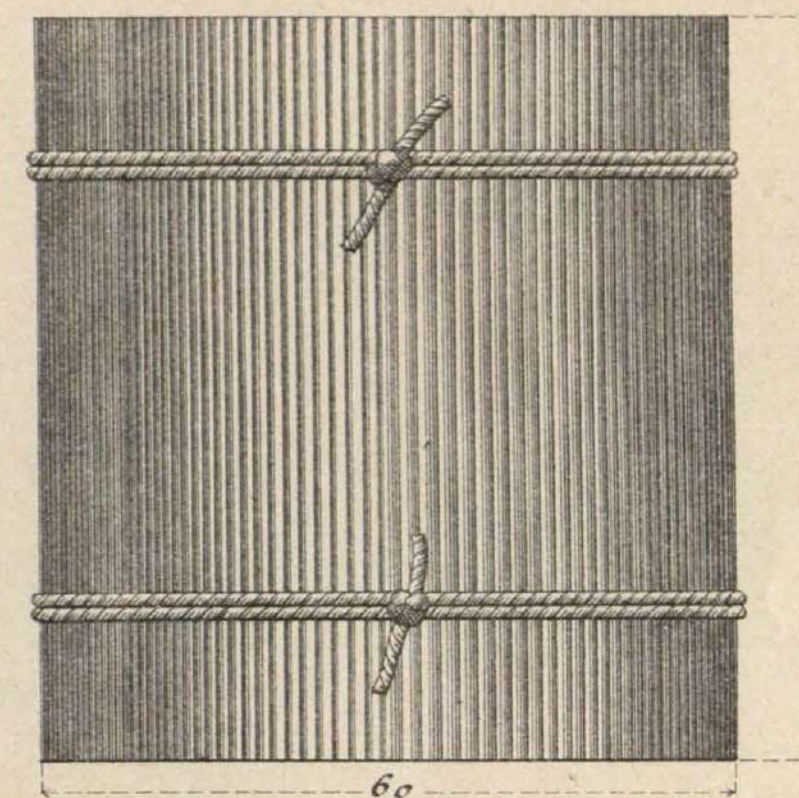

Carga 0,5425 Kg.  
3½ haces. 5ª Tabla.

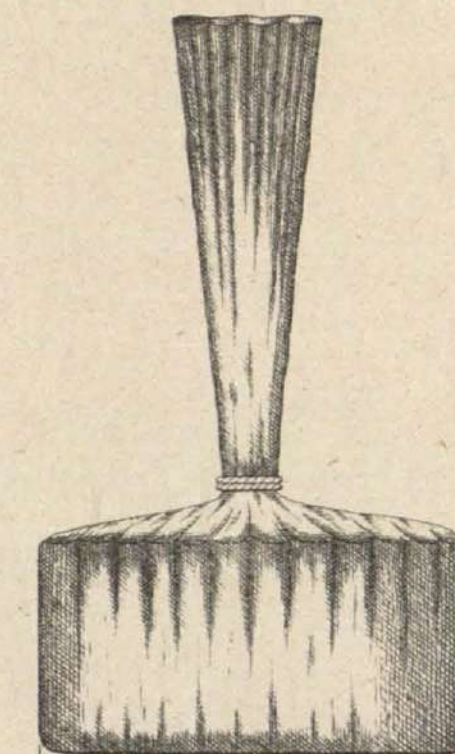

123

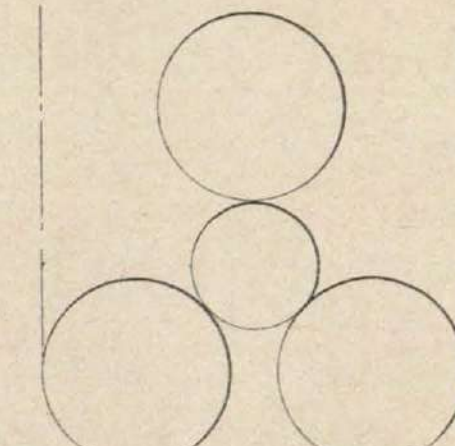

El saquete, es el mismo representado en la lámina 103-Série A-Tomo 7.º del Material de Artillería, disminuyendo su altura en 100 mm.

# OBUS Bc. 21 cm. MOD. 1885.

CARGAS Y CARTUCHOS QUE DEBEN CONFECCIONARSE CON LA PÓL. TUB. N.º 1 BIS.

Escala 3/10.

Carga de 2,325 Kgs.  
15 haces.

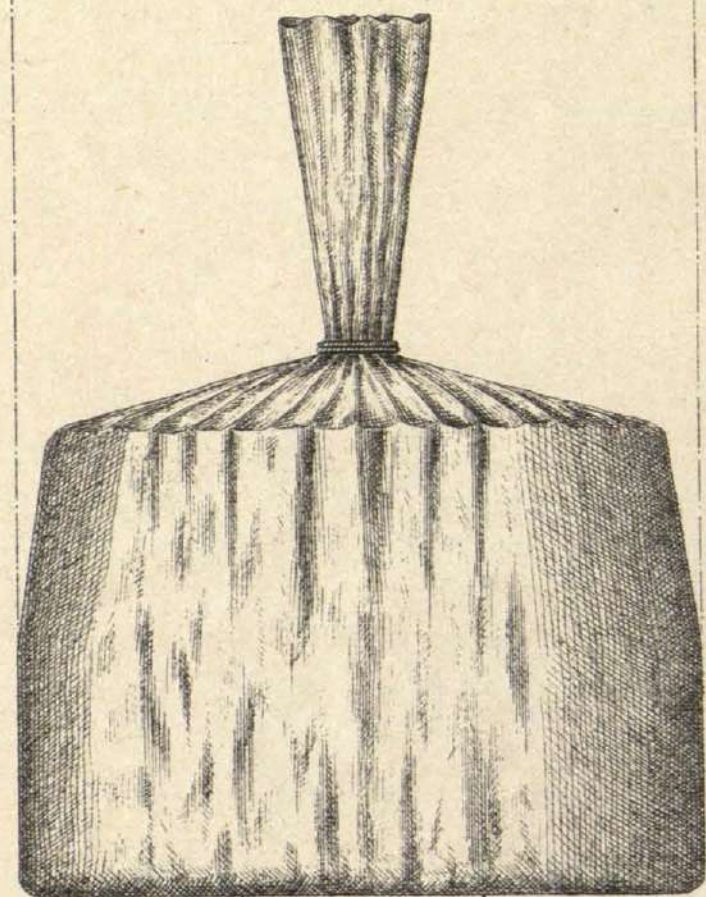
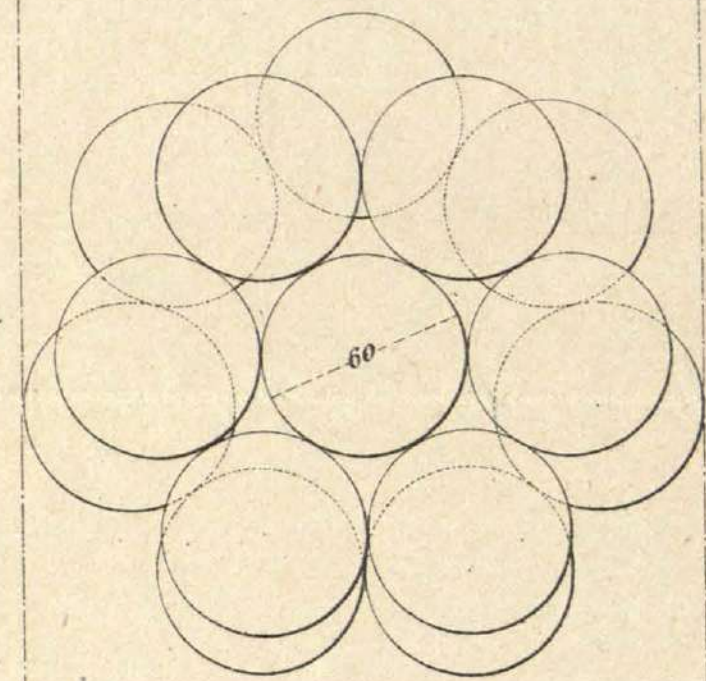
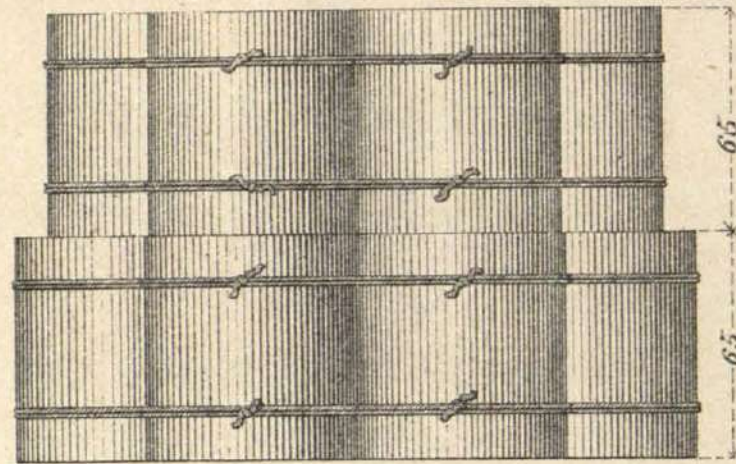

Carga de 2,015 Kgs.  
13 haces.

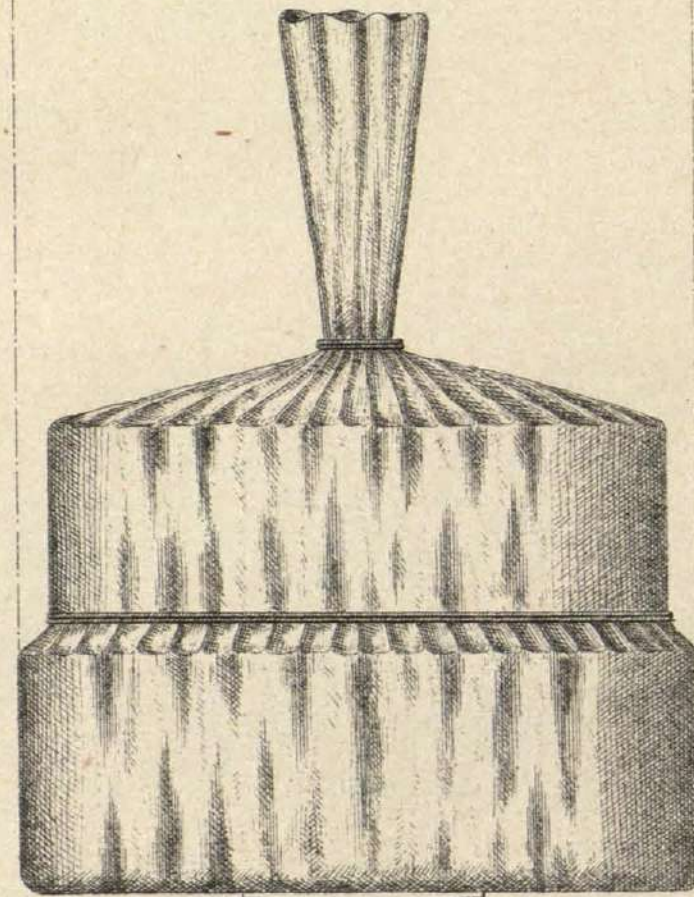
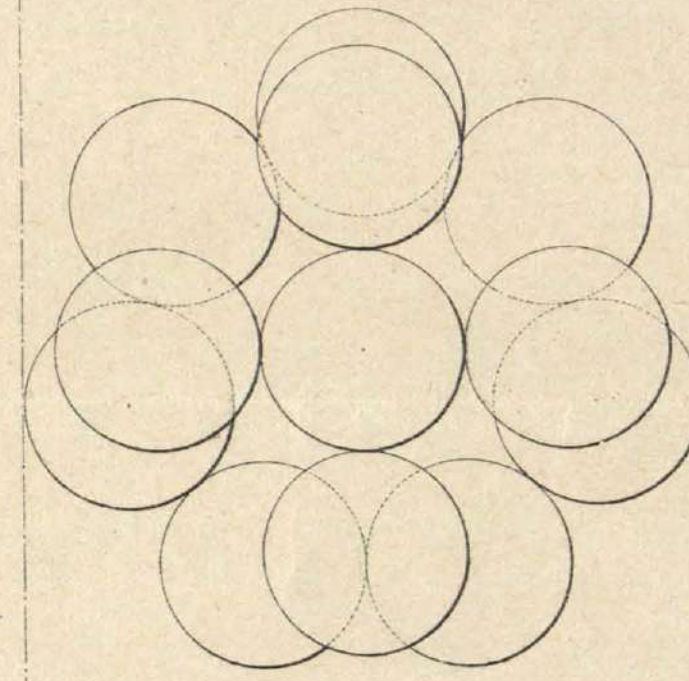
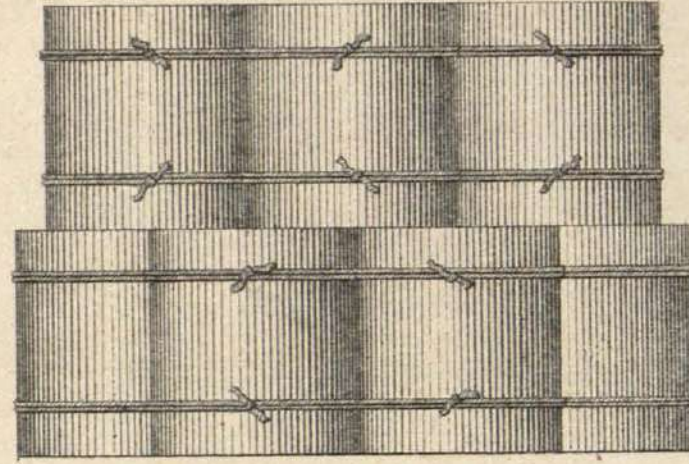

Carga de 1,705 Kgs.  
11 haces.

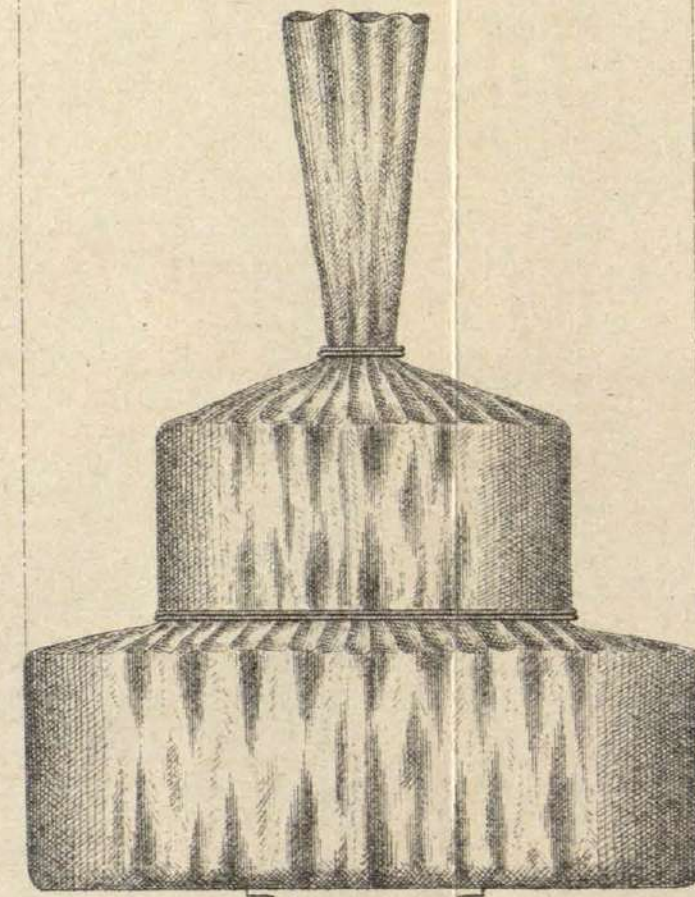
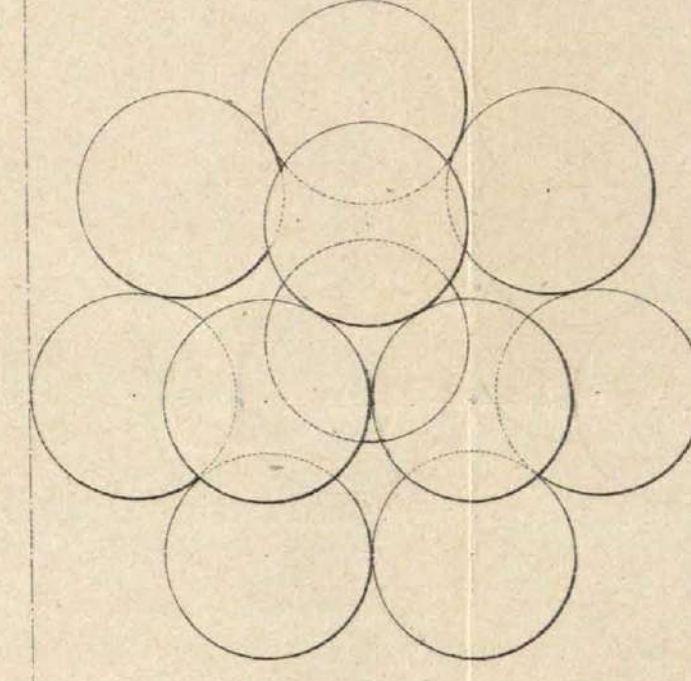
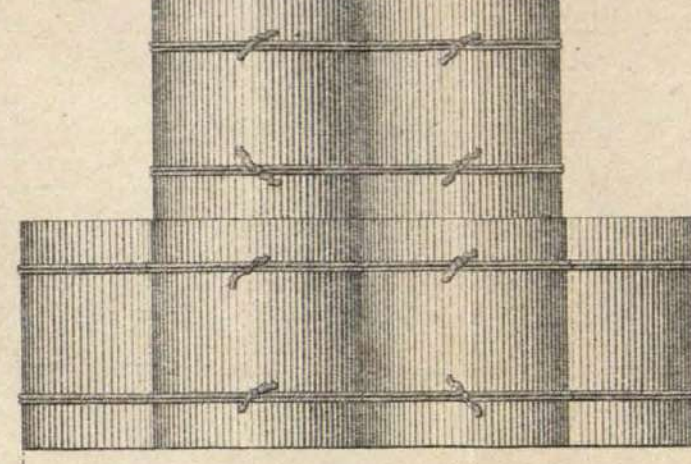

Carga de 1,395 Kgs.  
9 haces.

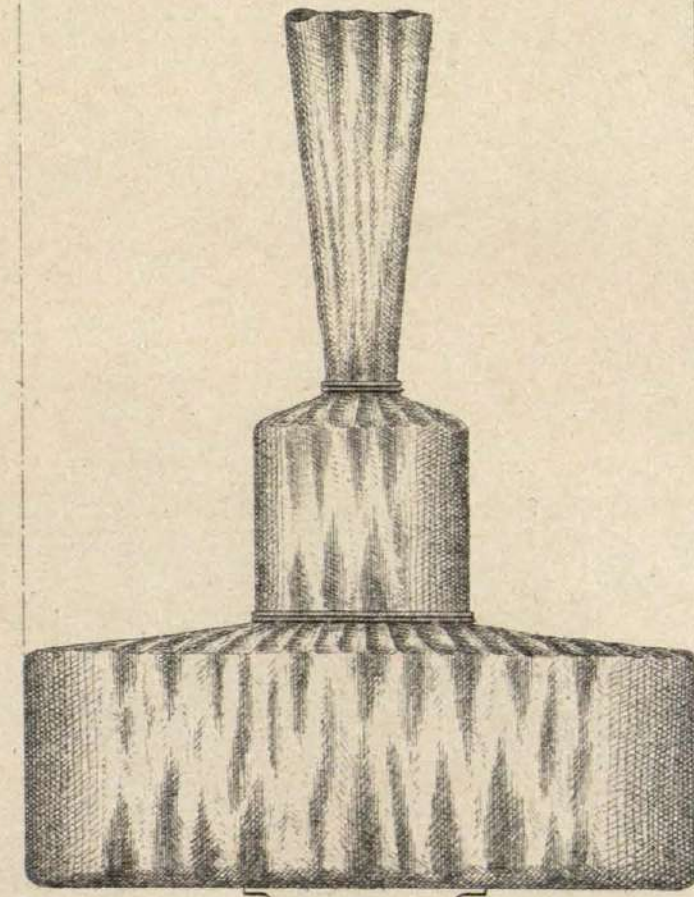
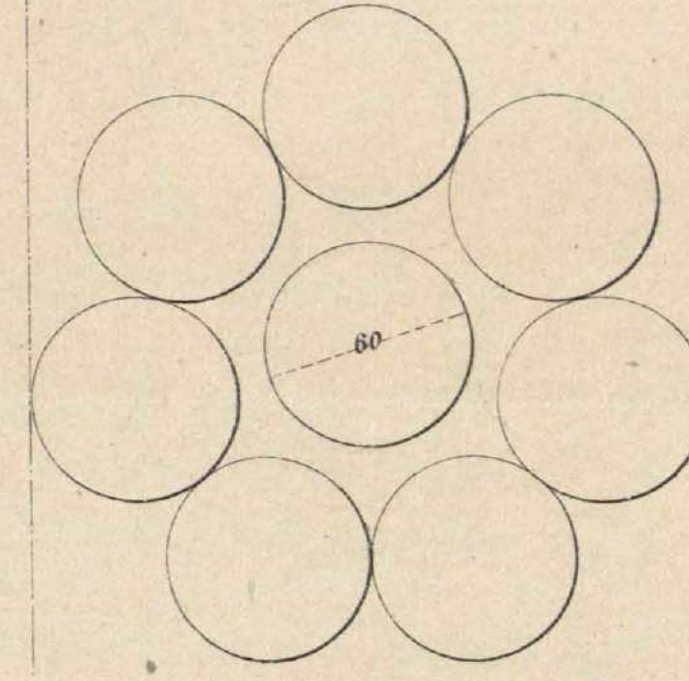
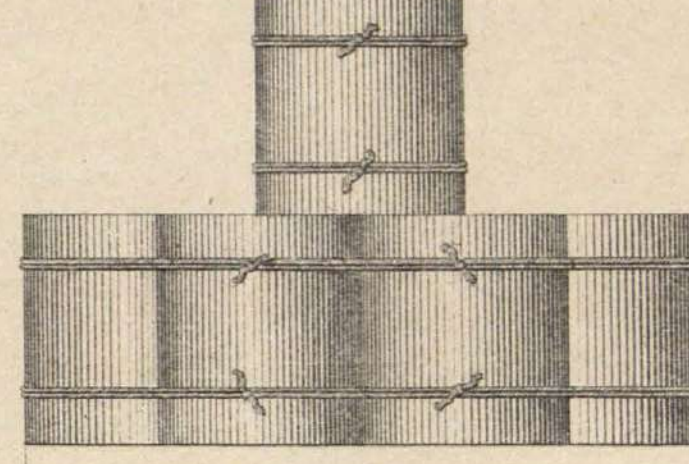

Carga de 1,085 Kgs.  
7 haces.

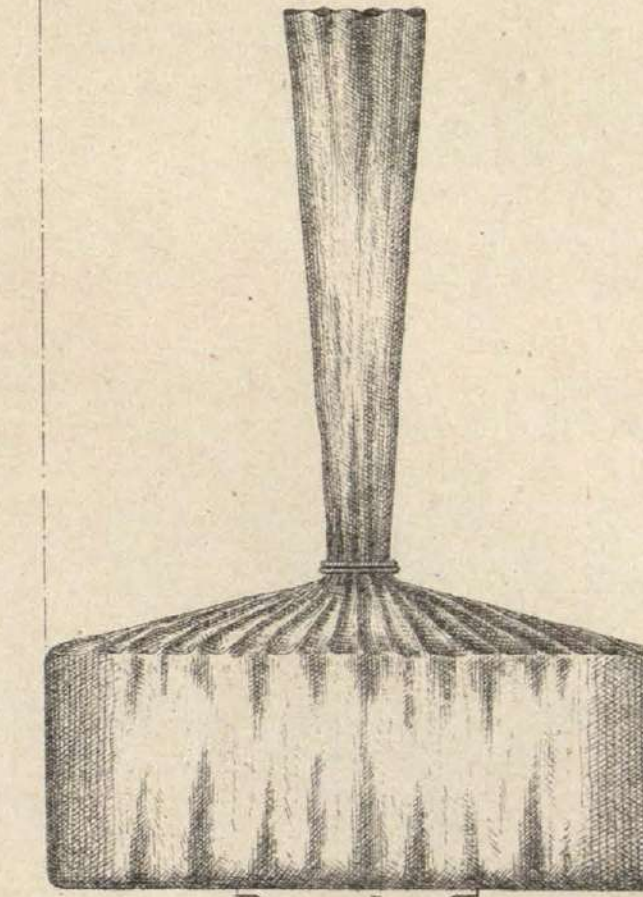
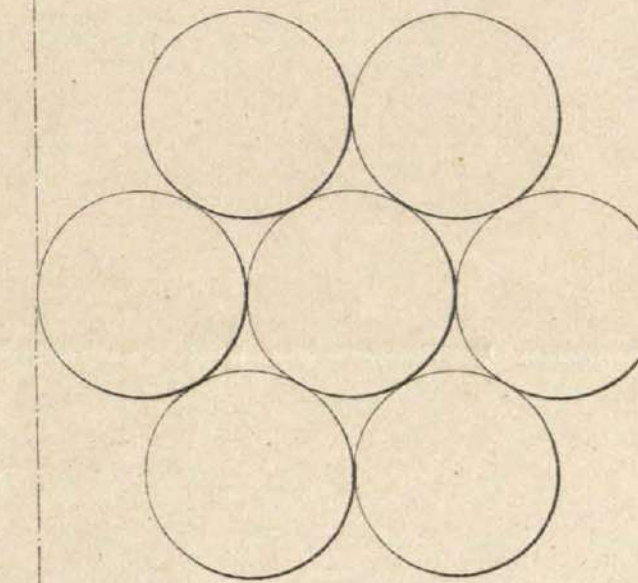
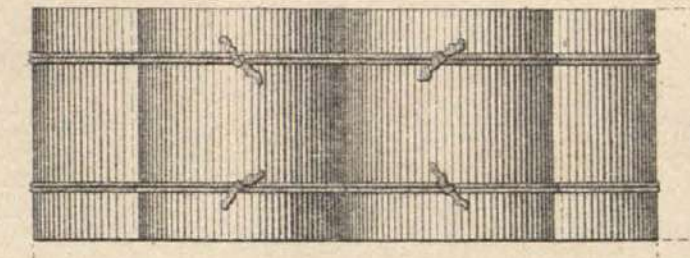

Desarrollo del saquete.  
(E= 1/10.)

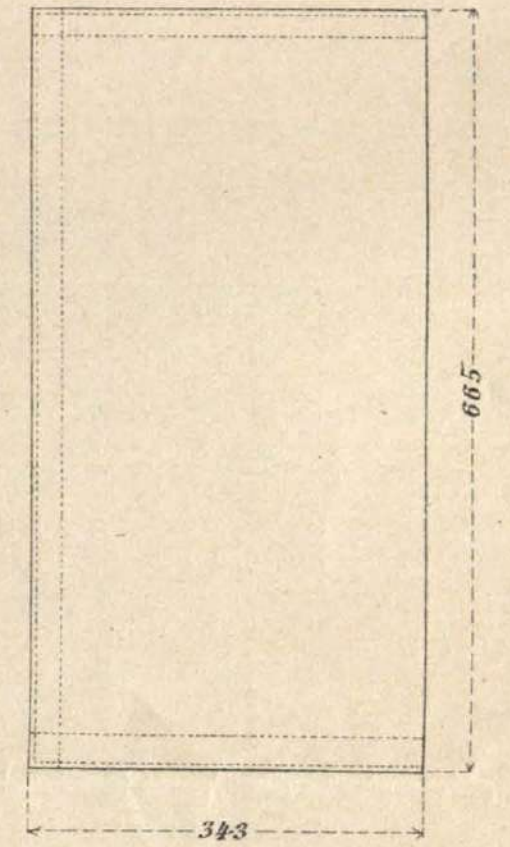

Desarrollo del culote. (E= 2/10.)

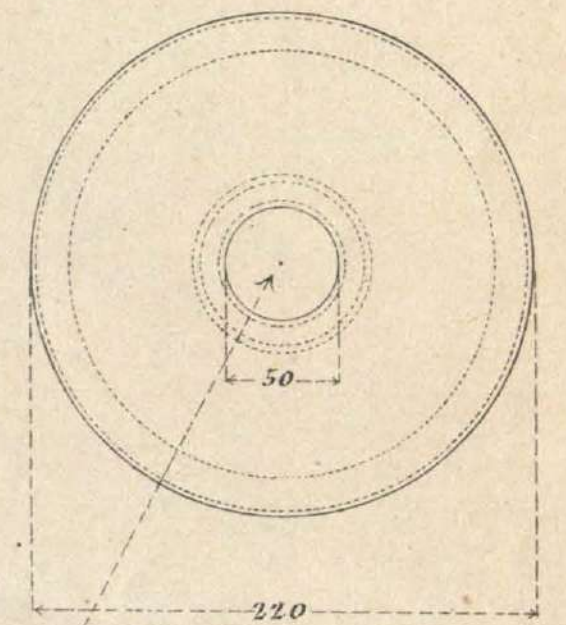

Cebo de pólvora negra de 1 m.m.  
(10 gramos.)

# MORTERO Bc. 9 cm. Md. 1891

## CARGAS DE PROYECCIÓN DE PÓLVORAS SIN HUMO.

Escala 1/1

Cuerpo del saquete (filóseda) E=1/2

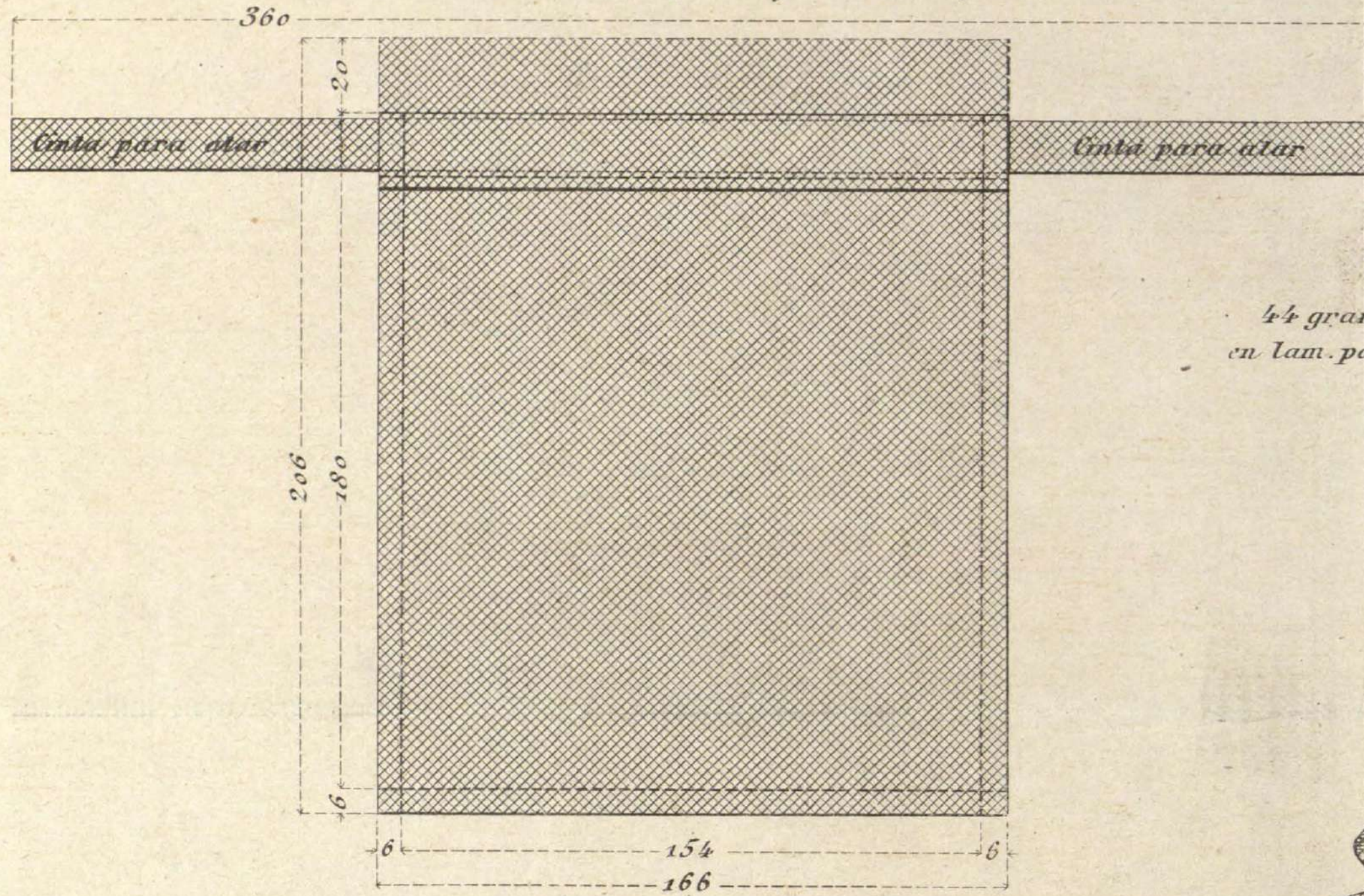

Culote del saquete

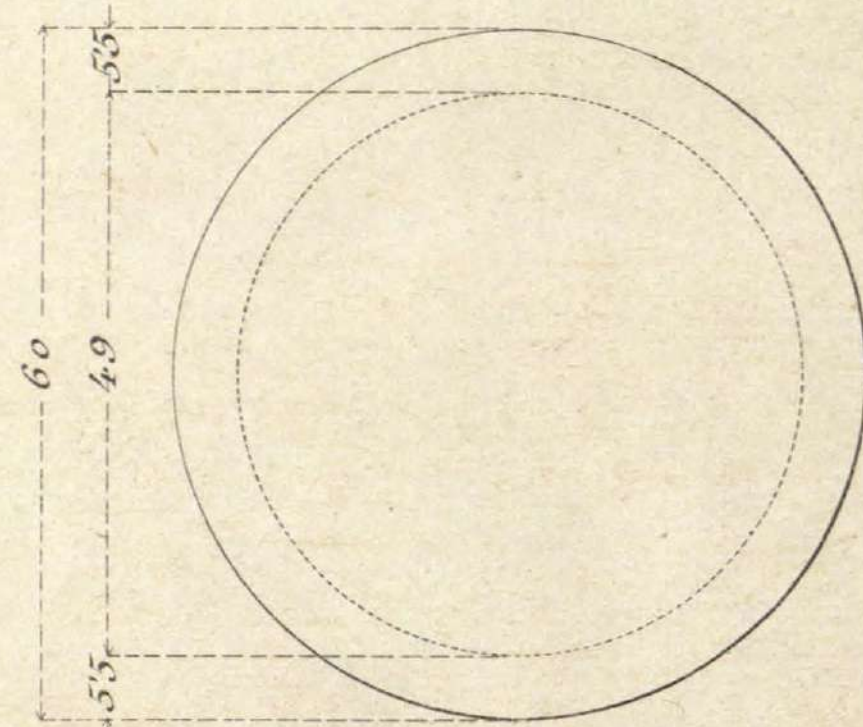

7ª Carga

44 gramos de pol. sin humo en lam. para fusil Maüser fil. 34

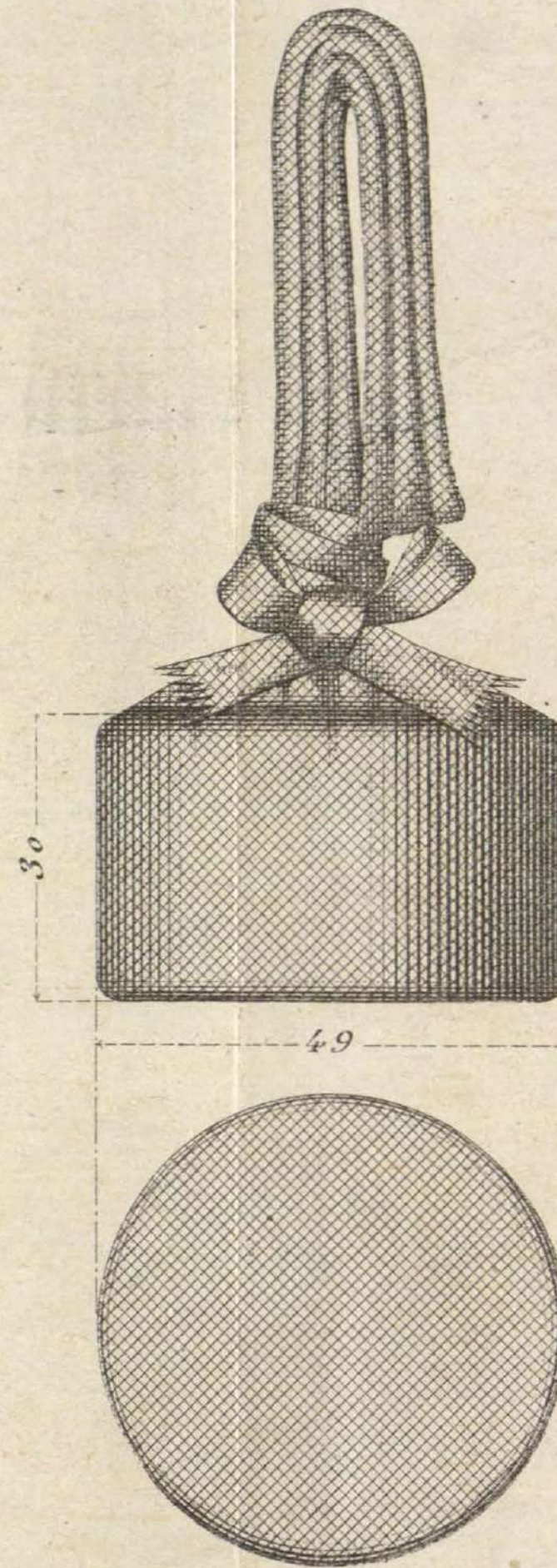

4ª Carga

100 gramos de pol. sin humo en lam. para fusil Maüser fil. 34.

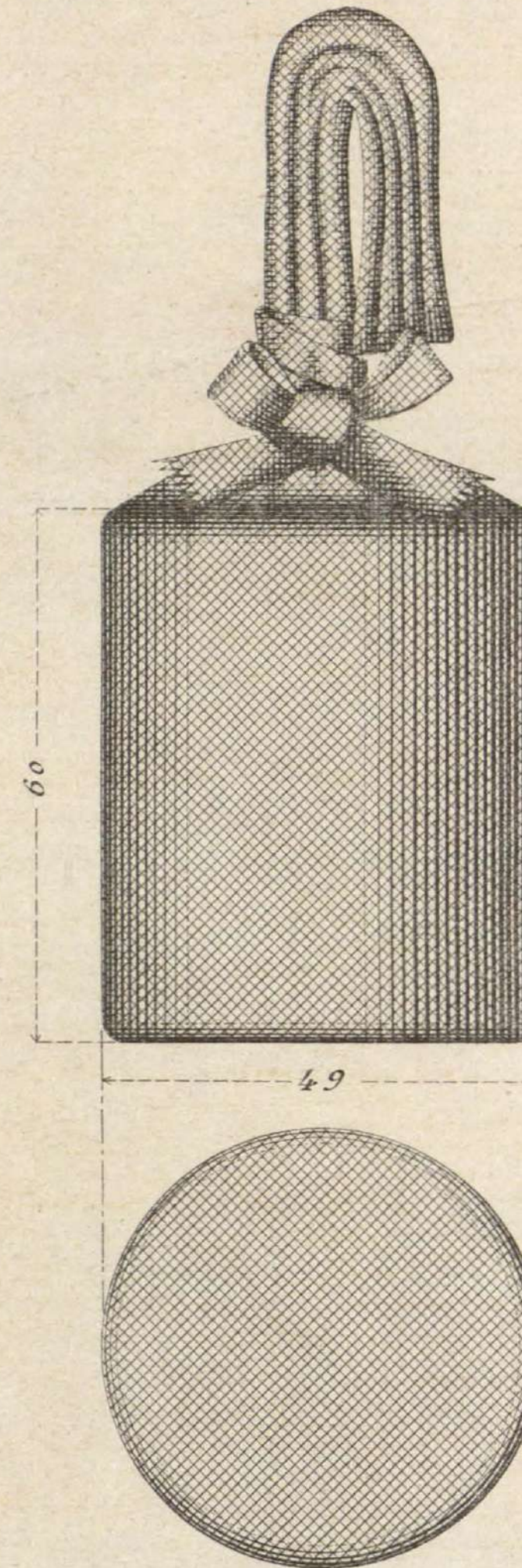

1ª Carga

210 gramos de pol. sin humo en lam. para fusil Maüser fil. 34

