

IMPRESA,
Librería y Encuadernación
de
Rafael Gómez-Menor
57, Comercio, 57
TOLEDO

IV
11-10-40

COLECCIÓN

DE

LÁMINAS DEL MATERIAL

DE LA

ARTILLERÍA ESPAÑOLA

(Comprende las publicadas desde Octubre de 1908 á Diciembre de 1913.)



TOMO XI

MADRID

IMPRENTA DE EDUARDO ARIAS

SAN LORENZO, NÚM. 5

—
1913

INDICE

del tomo XI de la Colección de láminas del Material de Artillería española,
que comprende las publicadas desde Octubre de 1908 á Diciembre de 1913.

Material de campaña de 75 mm. Saint-Chamond.

| | |
|--------|--------------------------------------------------------|
| LÁMINA | 1. ^a Cureña. (Vista vertical.) |
| — | 2. ^a Idem. (Vista horizontal.) |
| — | 3. ^a Cañón. (Vista general.) |
| — | 4. ^a Soportes del punto de mira y del alza. |
| — | 5. ^a Cañón. (Detalles.) |
| — | 6. ^a Idem. (Vistas del cierre.) |
| — | 7. ^a Idem. (Idem. íd.) |
| — | 8. ^a Detalles del cierre. |
| — | 9. ^a Cuerpo de la cureña. |
| — | 10 Detalles de ídem. |
| — | 11 Idem íd. íd. |
| — | 12 Idem íd. íd. |
| — | 13 Aparato de puntería en altura. |
| — | 14 Idem íd. (Detalles.) |
| — | 15 Aparato de puntería en dirección. |
| — | 16 Idem íd. (Detalles.) |
| — | 17 Freno hidráulico. |
| — | 18 Idem íd. (Detalles.) |
| — | 19 Idem íd. (Idem.) |
| — | 20 Freno de marcha. |
| — | 21 Idem íd. (Detalles.) |
| — | 22 Caja de entre-gualderas. |
| — | 23 Eje y detalles. |
| — | 24 Rueda y detalles. |
| — | 25 Juegos de armas. |
| — | 26 Idem íd. |
| — | 27 Alza y punto de mira. |

Material Krupp de 75 mm.

| | |
|--------|------------------------------|
| LÁMINA | 28 Cureña. (Vista vertical.) |
| — | 29 Idem. (Vista horizontal.) |
| — | 30 Cañón. (Vista general.) |
| — | 31 Idem. (Detalles.) |
| — | 32 Idem. (Idem.) |
| — | 33 Vistas del cierre. |

| | |
|--------|-----------------------------------------------|
| LÁMINA | 34 Detalles del cierre. |
| — | 35 Idem íd. |
| — | 36 Idem de la cureña. |
| — | 37 Palanca de dirección y detalles. |
| — | 38 Gualderín. (Detalles.) |
| — | 39 Aparato de puntería en dirección. |
| — | 40 Idem íd. íd. (Detalles.) |
| — | 41 Idem íd. íd. |
| — | 42 Idem íd. íd. (Detalles.) |
| — | 43 Freno de marcha. |
| — | 44 Idem íd. (Detalles.) |
| — | 45 Idem hidráulico. |
| — | 46 Idem íd. (Detalles.) |
| — | 47 Idem íd. (Idem.) |
| — | 48 Eje y detalles. |
| — | 49 Rueda y detalles. |
| — | 50 Armón. (Vista vertical.) |
| — | 51 Idem. (Idem horizontal.) |
| — | 52 Eje del ídem y detalles. |
| — | 53 Pinzote y lanza. |
| — | 54 Vista vertical del carro. |
| — | 55 Idem horizontal del ídem. |
| — | 56 Eje y detalles del ídem. |
| — | 57 Caja del armón. |
| — | 58 Idem íd. |
| — | 59 Idem de municiones. |
| — | 60 Alza y punto de mira. |
| — | 61 proyectiles. |
| — | 62 Granada rompedora. |
| — | 63 Idem íd. (Detalles.) |
| — | 64 Espoleta de percusión Md. 1896. |
| — | 65 Idem de doble efecto Md. 1907. (Detalles.) |
| — | 66 Idem íd. íd. (Idem.) |
| — | 67 Cajas de entre-gualderas. |
| — | 68 Idem de armón y carro. |

Material de campaña de 75 cm., Schneider Md. 1906.

| | |
|--------|------------------------------|
| LÁMINA | 69 Cureña. (Vista vertical.) |
| — | 70 Idem. (Idem horizontal.) |

| | |
|--------|-------------------------------------------------|
| LÁMINA | 71 Cañón. (Vista general.) |
| — | 72 Idem. (Detalles.) |
| — | 73 Vistas del cierre. |
| — | 74 Detalles del ídem. |
| — | 75 Idem íd. |
| — | 76 Idem íd. |
| — | 77 Idem de la cureña. |
| — | 78 Idem íd. íd. |
| — | 79 Idem del arado. |
| — | 80 Idem íd. |
| — | 81 Idem íd. |
| — | 82 Aparato disparador. |
| — | 83 Freno de marcha. (Detalles.) |
| — | 84 Idem íd. (Idem.) |
| — | 85 Palanca de dirección y detalles. |
| — | 86 Detalles del asiento de sirviente de cureña. |
| — | 87 Enganche para inmovilizar la cuna. |
| — | 88 Aparato de puntería en altura. |
| — | 89 Idem íd. íd. (Detalles.) |
| — | 90 Idem íd. íd. (Idem.) |
| — | 91 Idem íd. íd. (Idem.) |
| — | 92 Idem. íd. íd. (Idem.) |
| — | 93 Idem íd. íd. (Idem.) |
| — | 94 Idem íd. en dirección. |
| — | 95 Idem íd. íd. (Detalles.) |
| — | 96 Idem íd. íd. (Idem.) |
| — | 97 Detalles de las muñoneras y sobremuñoneras. |
| — | 98 Manguito del eje de las ruedas. |
| — | 99 Eje y detalles. |
| — | 100 Rueda y detalles. |
| — | 101 Detalles del escudo. |

| | |
|--------|------------------------------------------------------------|
| LÁMINA | 102 Detalles del escudo. |
| — | 103 Idem íd. |
| — | 104 Idem de la cuna. |
| — | 105 Idem íd. |
| — | 106 Idem íd. |
| — | 107 Freno recuperador. |
| — | 108 Idem íd. (Detalles.) |
| — | 109 Idem íd. (Idem.) |
| — | 110 Trineo y detalles. |
| — | 111 Bomba y aparato para sacar la pieza de batería. |
| — | 112 Armón. (Vista vertical.) |
| — | 113 Idem. (Idem horizontal.) |
| — | 114 Cajas del armón. |
| — | 115 Eje y detalles |
| — | 116 Lanza y detalles. |
| — | 117 Carro. (Vista vertical.) |
| — | 118 Idem. (Idem horizontal.) |
| — | 119 Eje y detalles. |
| — | 120 Freno de marcha. |
| — | 121 Observatorio. |
| — | 122 Caja de accesorios, respetos y útiles. |
| — | 123 Distribución en las cajas de granadas rom- pedoras. |
| — | 124 Idem íd. íd. |
| — | 125 Cajas de útiles. |
| — | 126 Idem íd. |
| — | 127 Goniómetro de pieza. |
| — | 128 Anteojo de batería. |
| — | 129 Escobillón-atacador. |
| — | 130 Carro de batería. |

CUREÑA PARA CAÑON t. r. DE 75 mm. DE CAMPAÑA SAINT-CHAMOND

VISTA VERTICAL

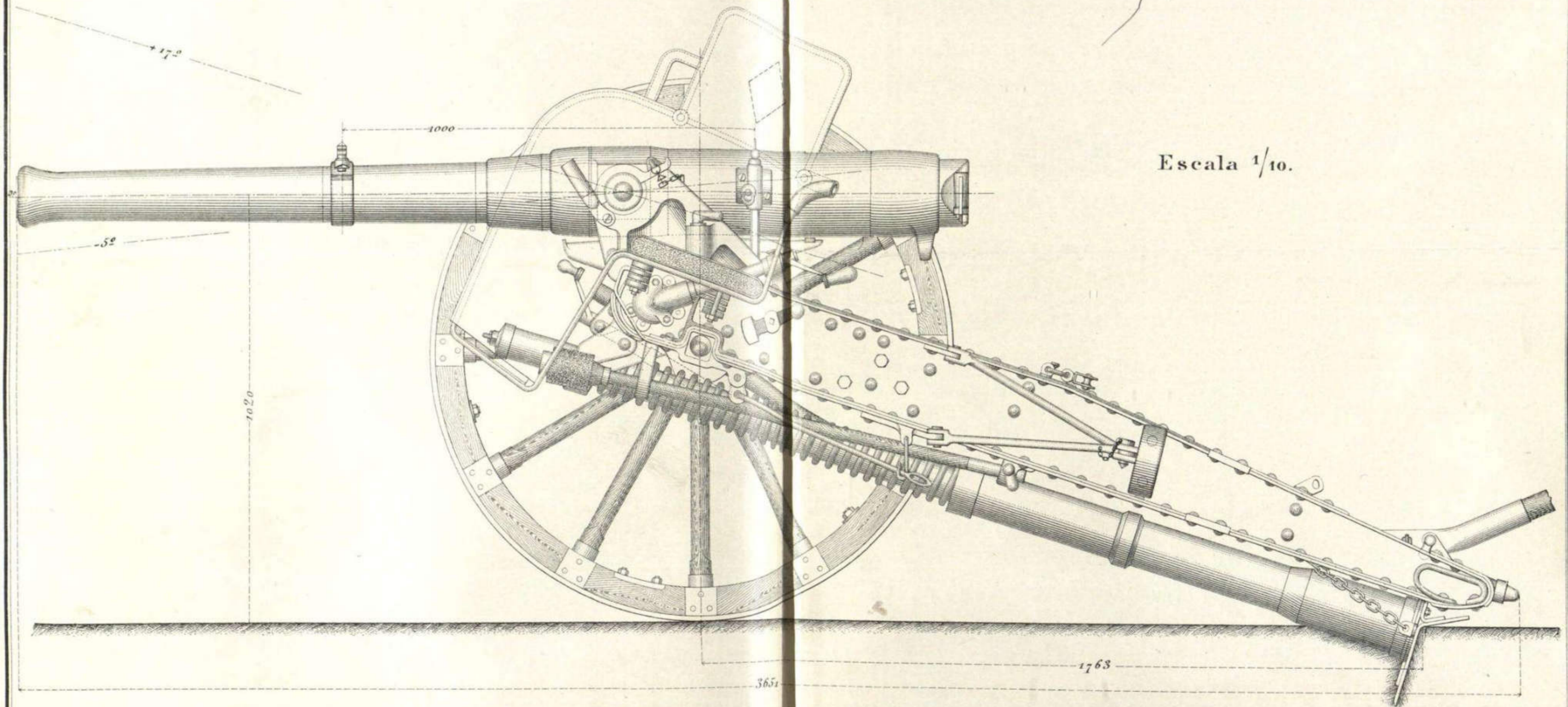

Escala 1/10.

CUREÑA PARA CAÑON t. r. DE 75 mm. DE CAMPAÑA SAINT-CHAMOND

VISTA HORIZONTAL

Escala 1/10

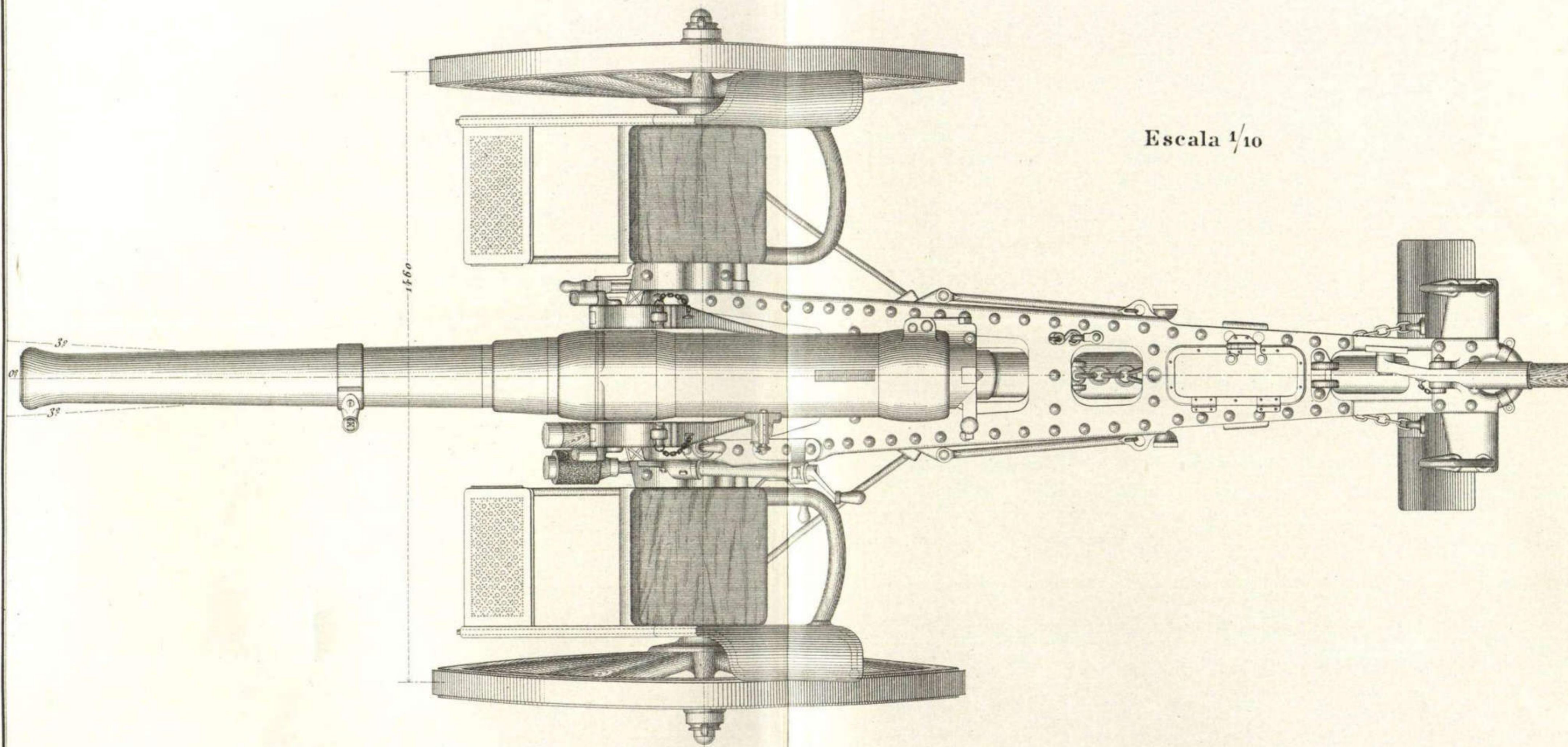

CAÑON t. r. DE 75 mm. DE CAMPAÑA SAINT-CHAMOND.

Escala 1⁵/10

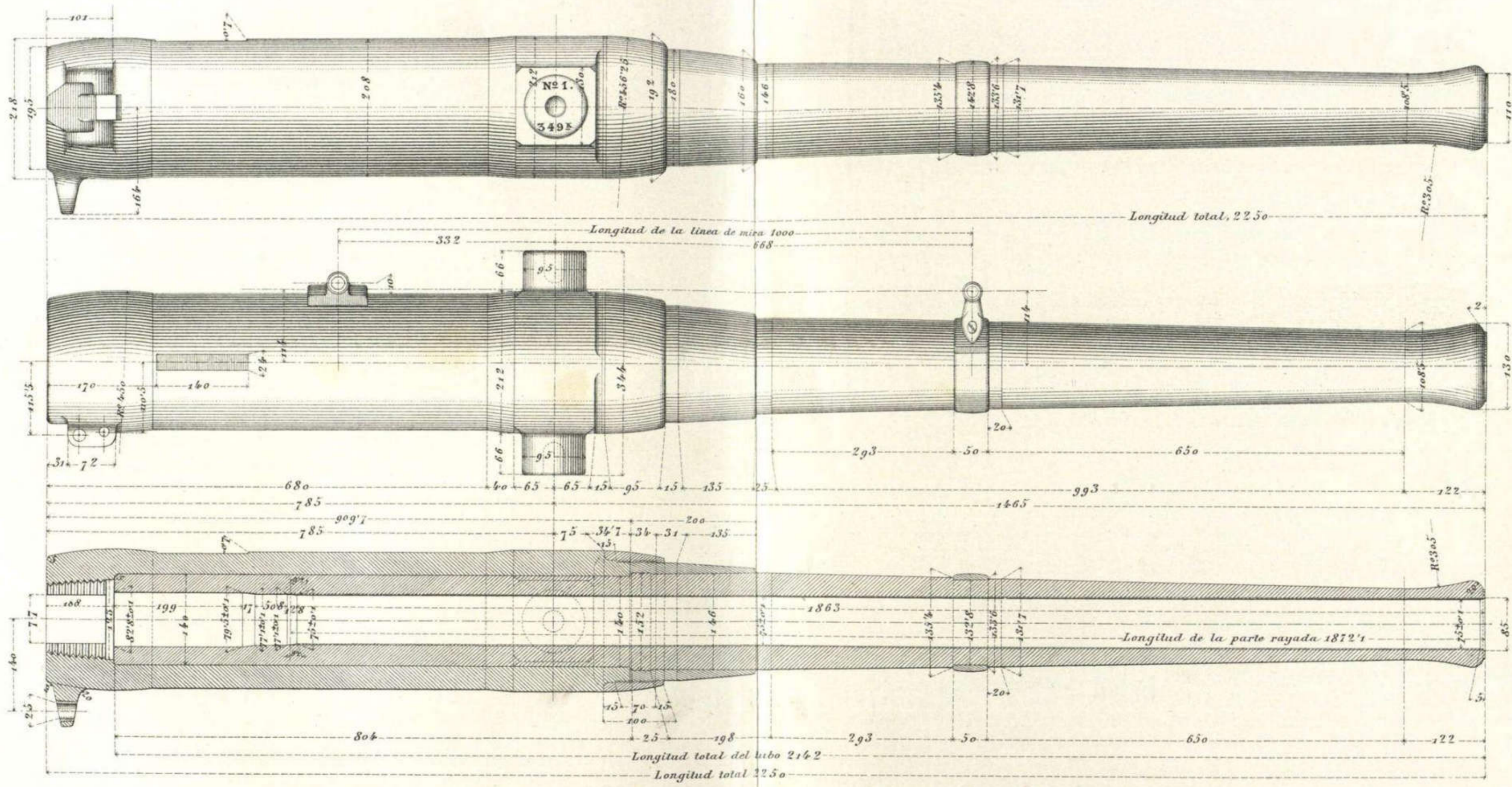

Peso del cañon completo sin carga 350 Kg. ± 2'5 %.

CAÑON t. r. DE 75 mm. DE CAMPAÑA SAINT-CHAMOND.

DETALLES.

Soporte del punto de mira. (5/10)

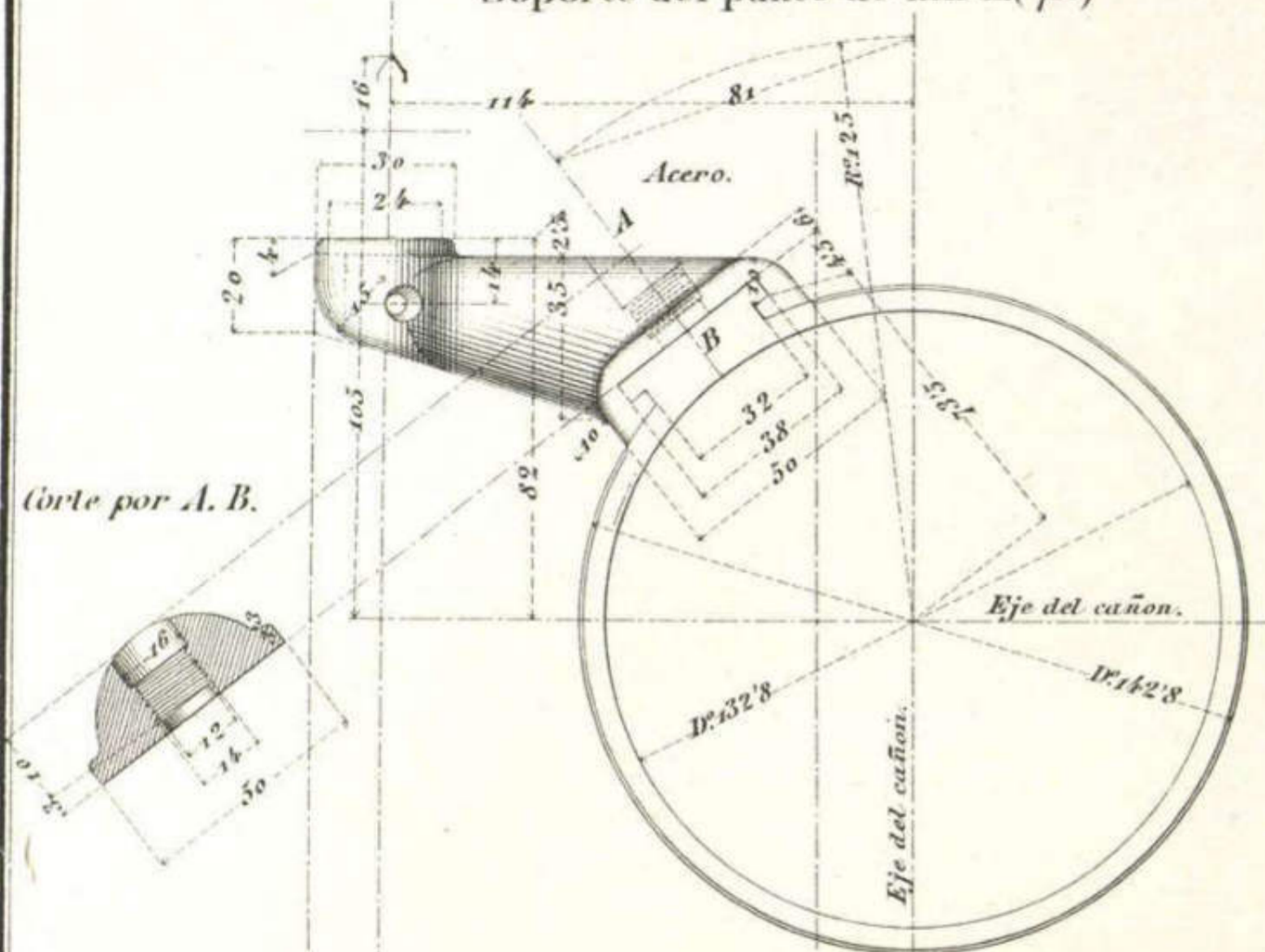

Cajera del alza. (5/10)
Acero forjado.

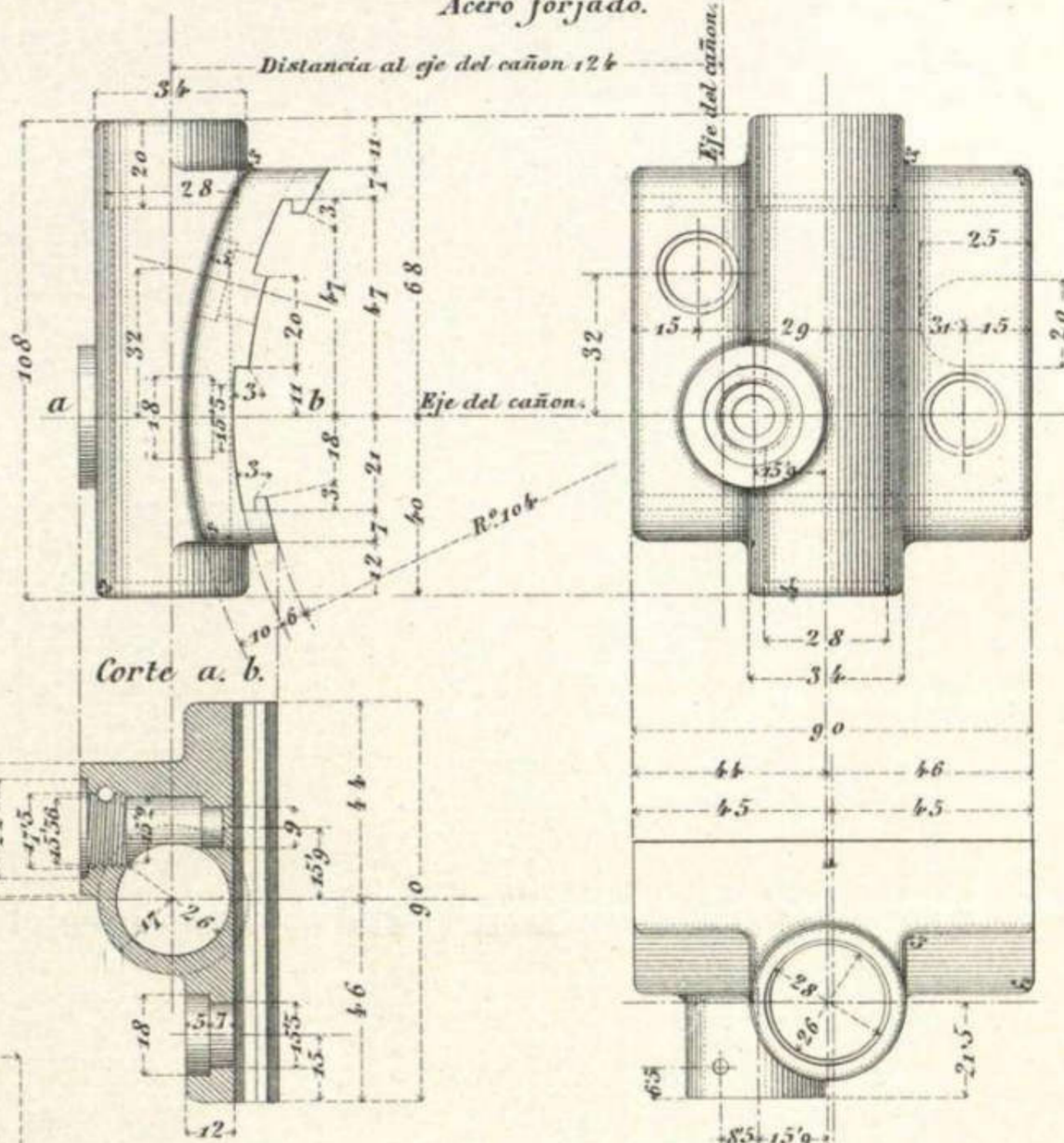

Dedal. (1/1)
Laton.

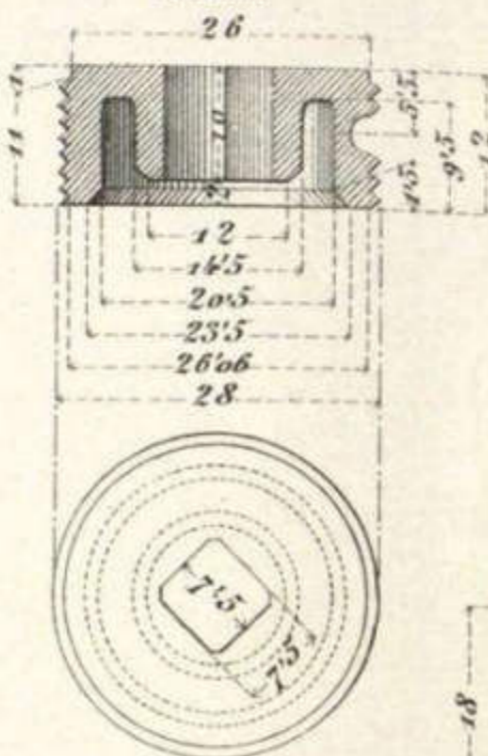

Muelle helicoidal (1/1)
Laton.

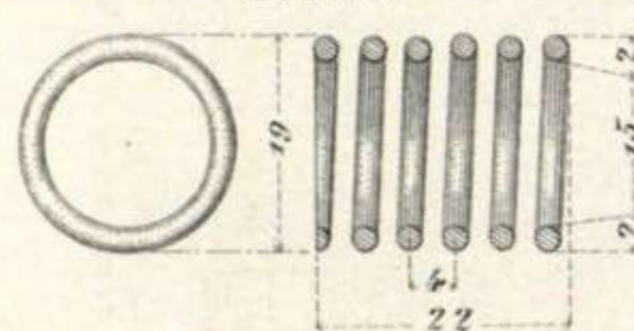

2 Tornillos. (1/1)
Acero.

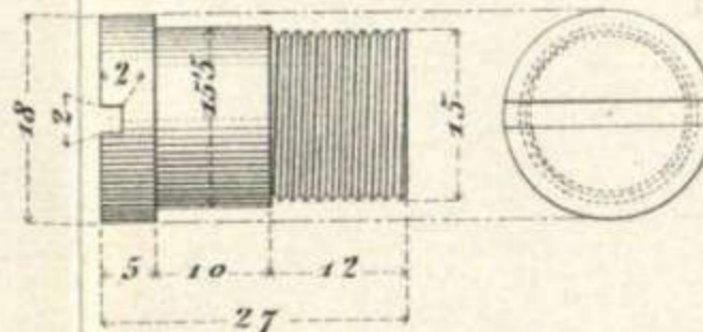

Pasador del soporte. (1/1)
Acero.

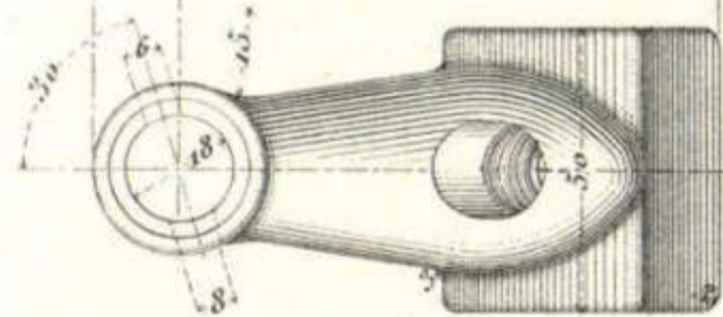

Tambor. (1/1)
Laton.

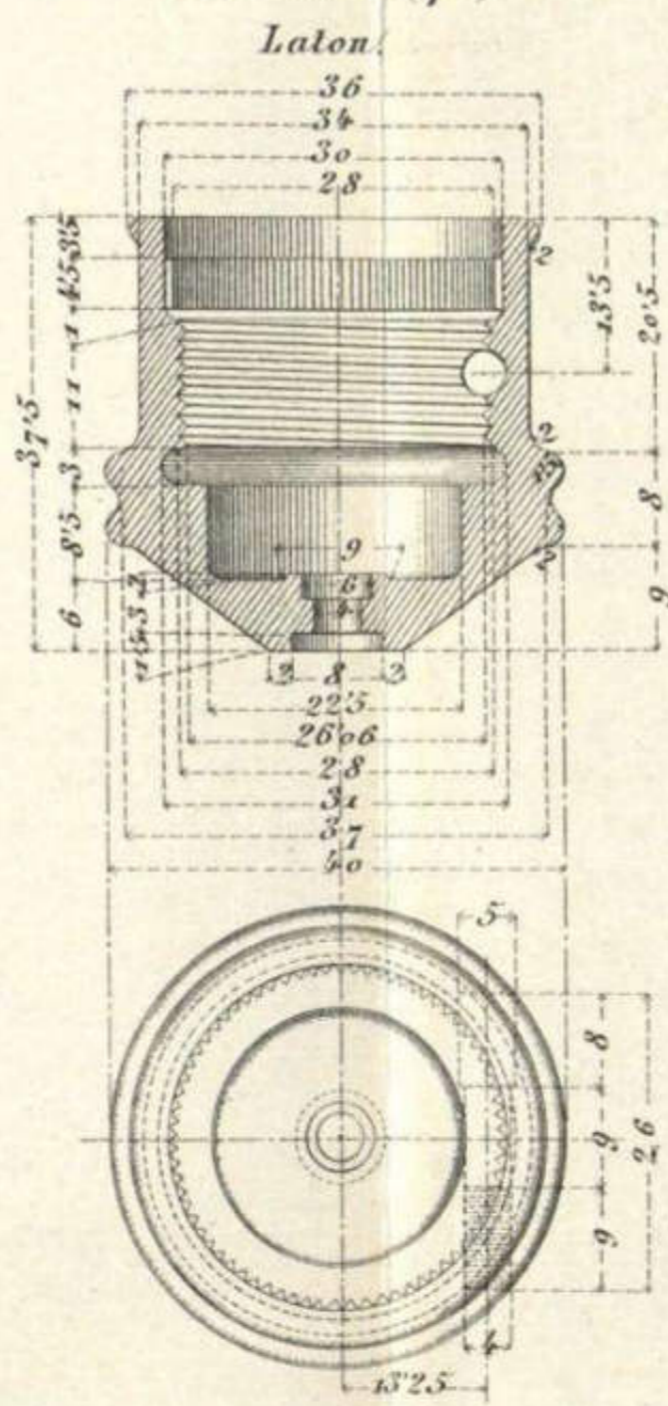

Eje. (8/10)
Acero.

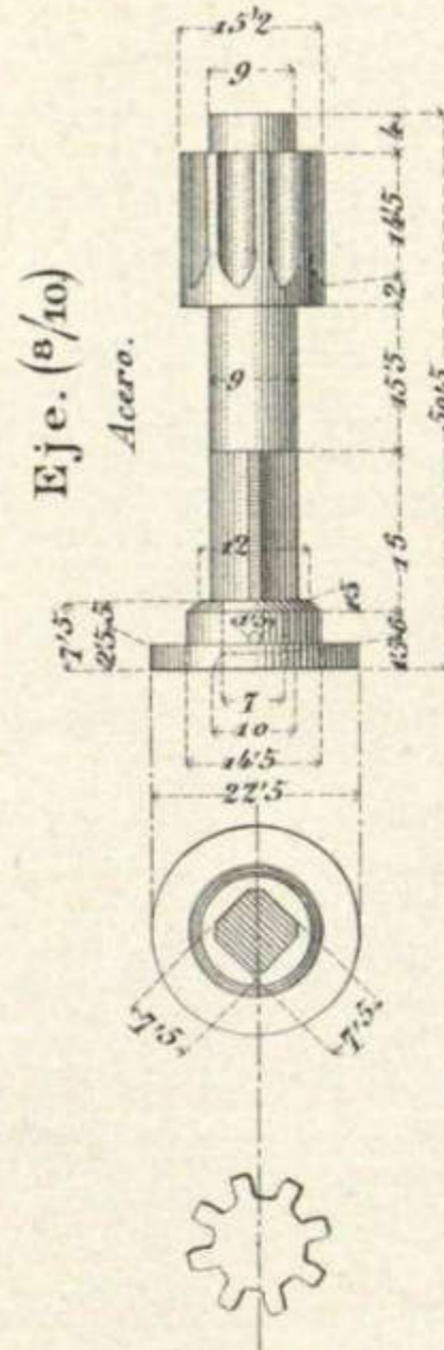

Cajera del alza. (5/10)
Laton.

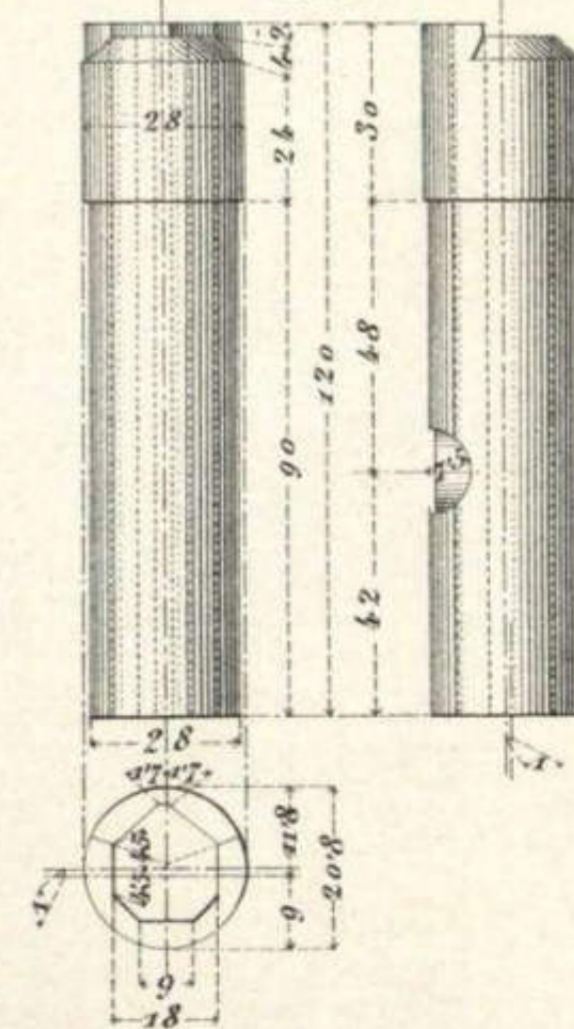

Tornillo del soporte. (1/1)
Acero especial.

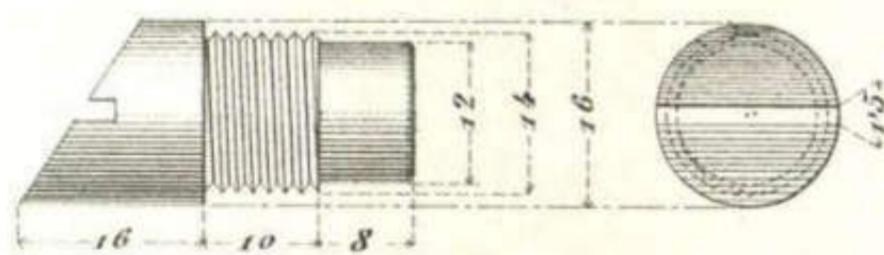

Viola. (1/1)
Laton.

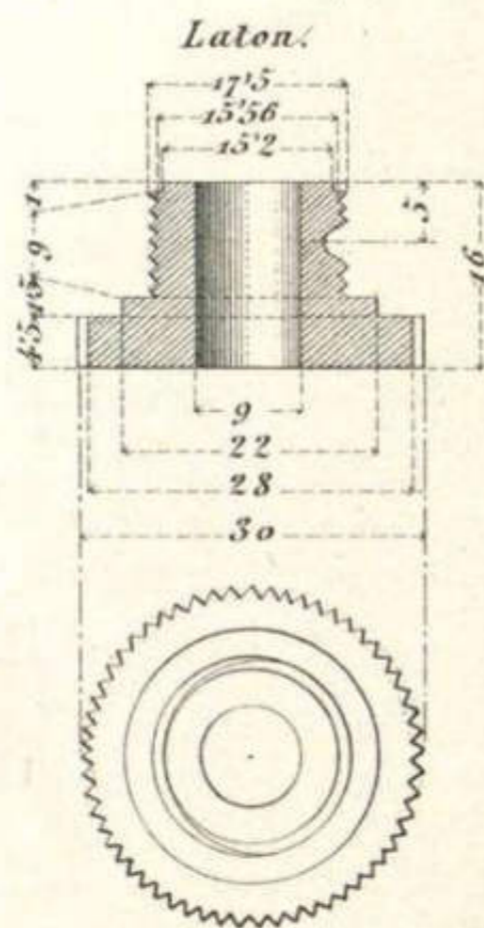

Anilla. (1/1)
Acero.

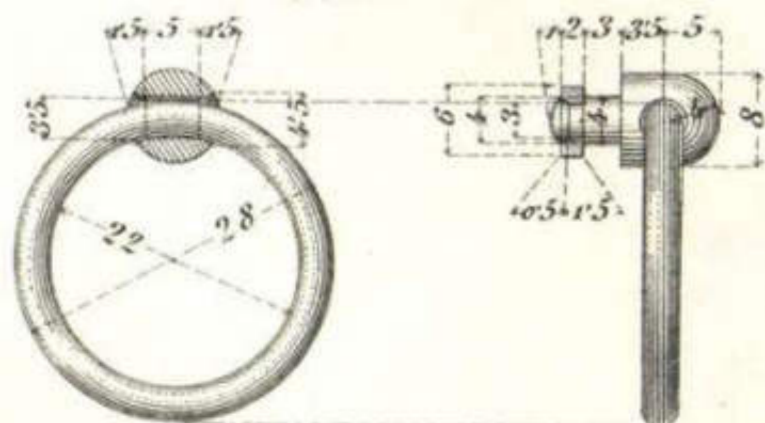

Pasador. (1/1)
Acero.



CAÑÓN t. r. DE 75 mm. DE CAMPAÑA SAINT-CHAMOND.

DE TALLERES.

Recámara (E=5/10)

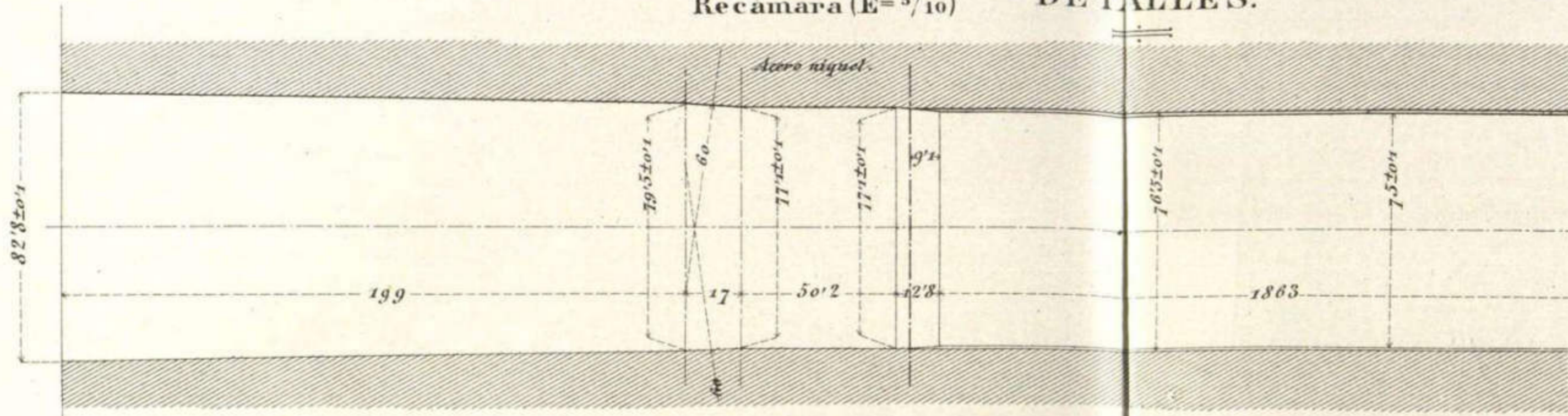

Plano de la boca. (E=5/10)

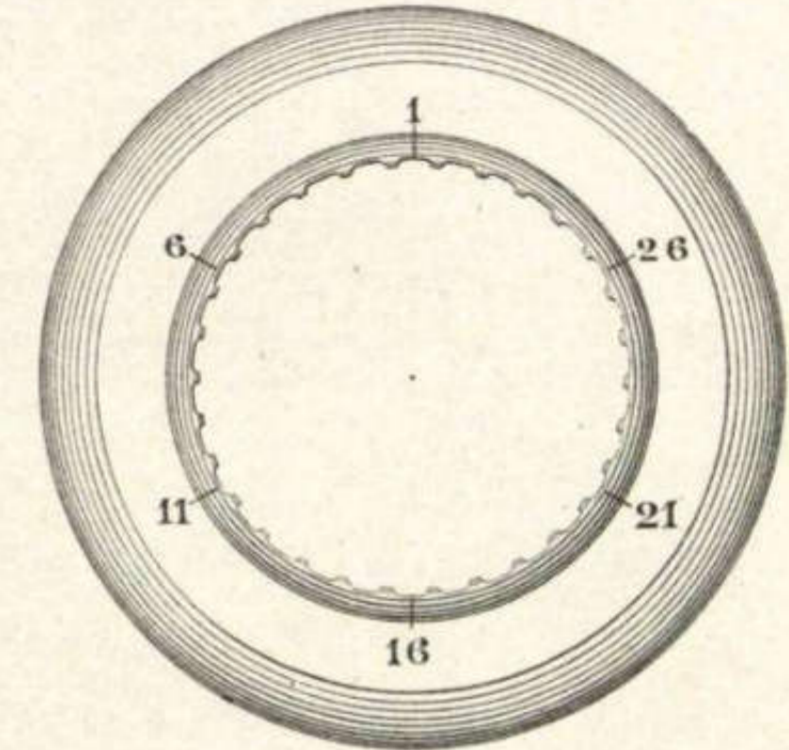

Alojamiento del proyectil en la recámara. (E=2/1)

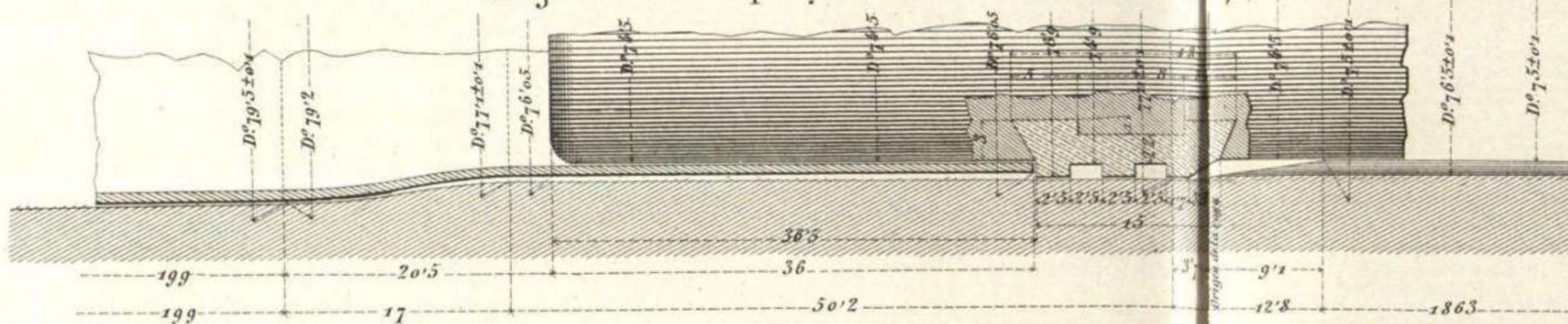

Rayado en la culata. (E=5/1)

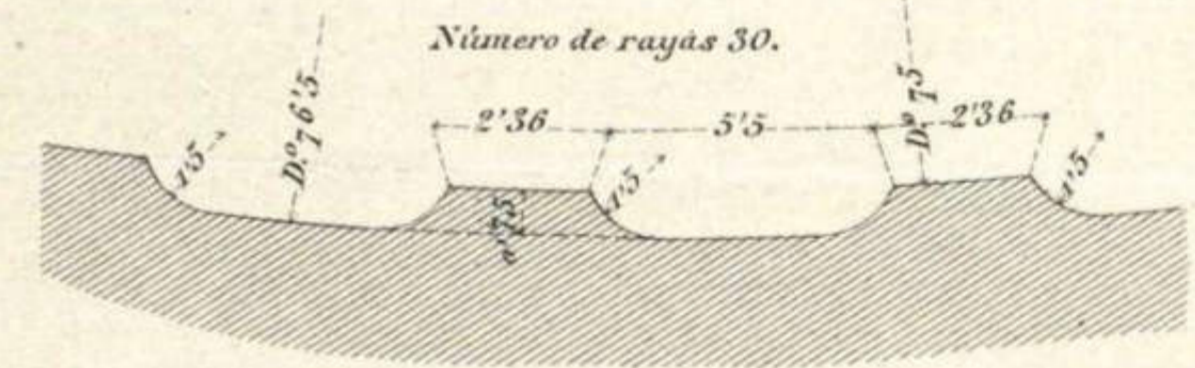

Trazado de una raya, desarrollada sobre un cilindro de 15 m/m. de diámetro. (Paso a la derecha.) E=1'5/10.

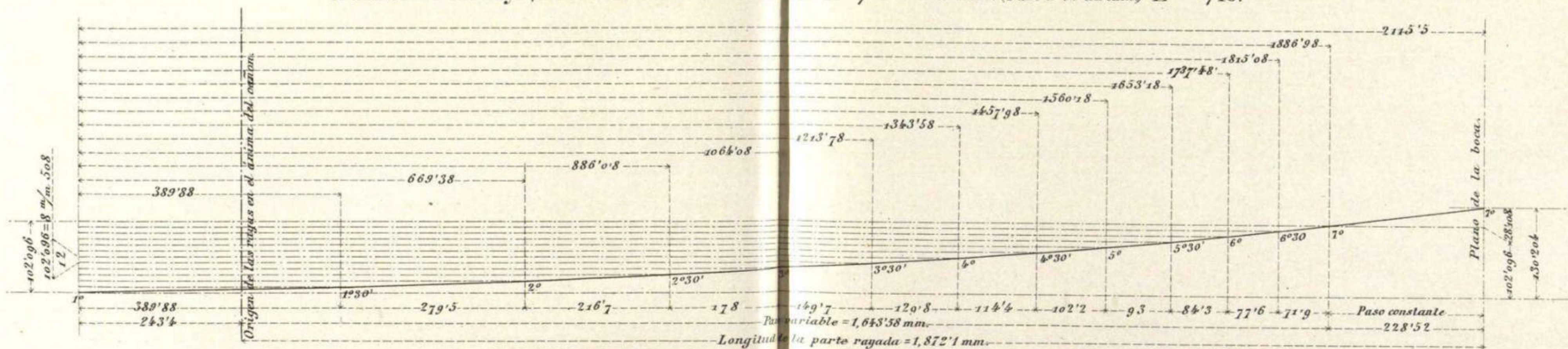

Notas. La raya que lleva el n.º 1 tiene su centro sobre la generatriz superior del plano de la boca, las demás rayas se suceden siguiendo el sentido de la rotación del proyectil.
 El ángulo que hace en cada punto la tangente a la curva con la generatriz del ánima, está indicado sobre la ordenada correspondiente a este punto.
 Entre los puntos determinados por el trazado, la curva puede asimilarse a un arco de círculo. La raya cuyo paso es variable sobre una longitud de 1,643'58 mm. a partir del origen, termina del lado de la boca, en una longitud de 228'52 mm. por una parte de paso constante correspondiente a la inclinación de 7 grados.

CAÑON t. r. DE 75 mm. DE CAMPAÑA SAINT-CHAMOND.

VISTAS DEL CIERRE.

Escala 5/10.

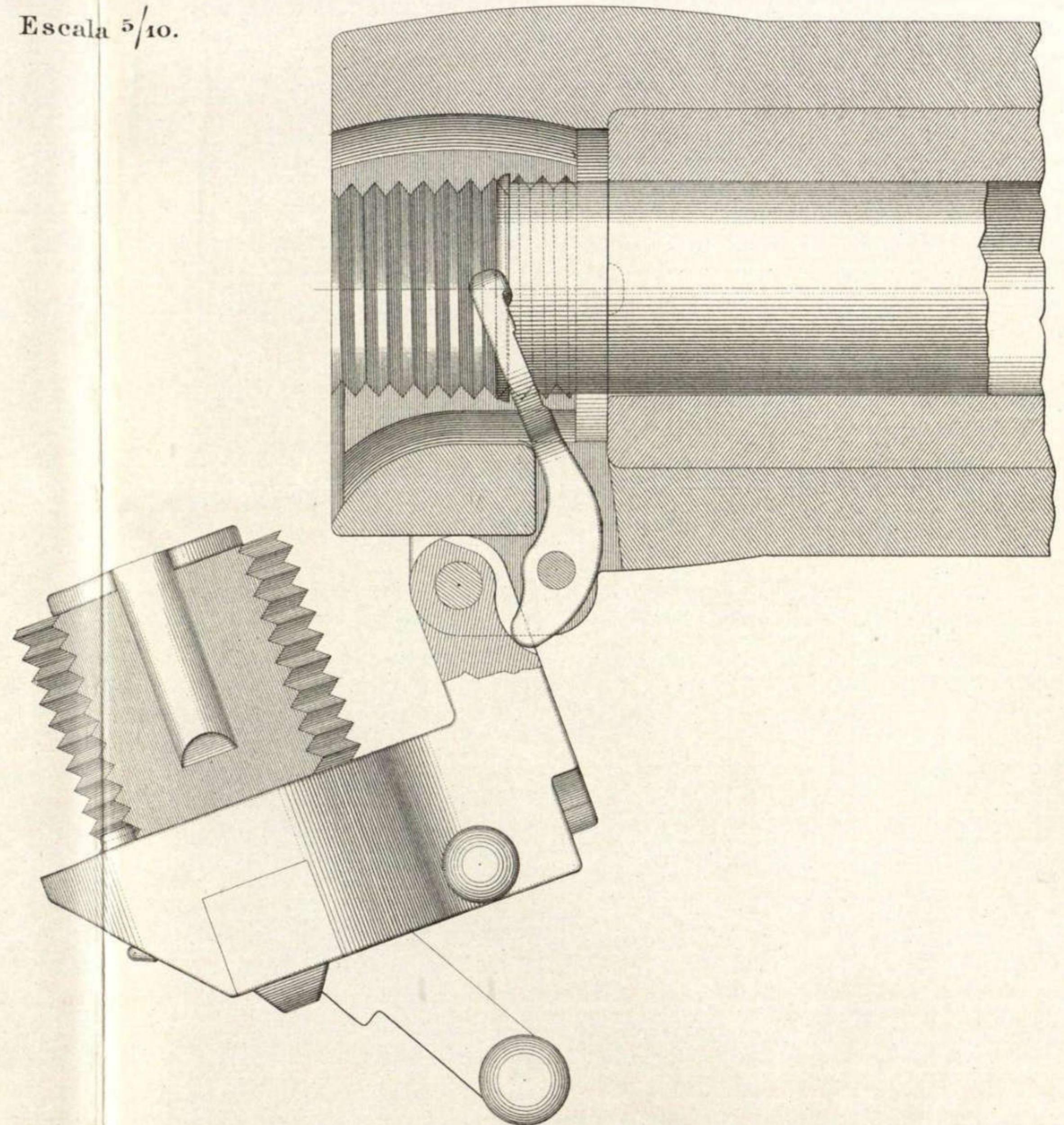
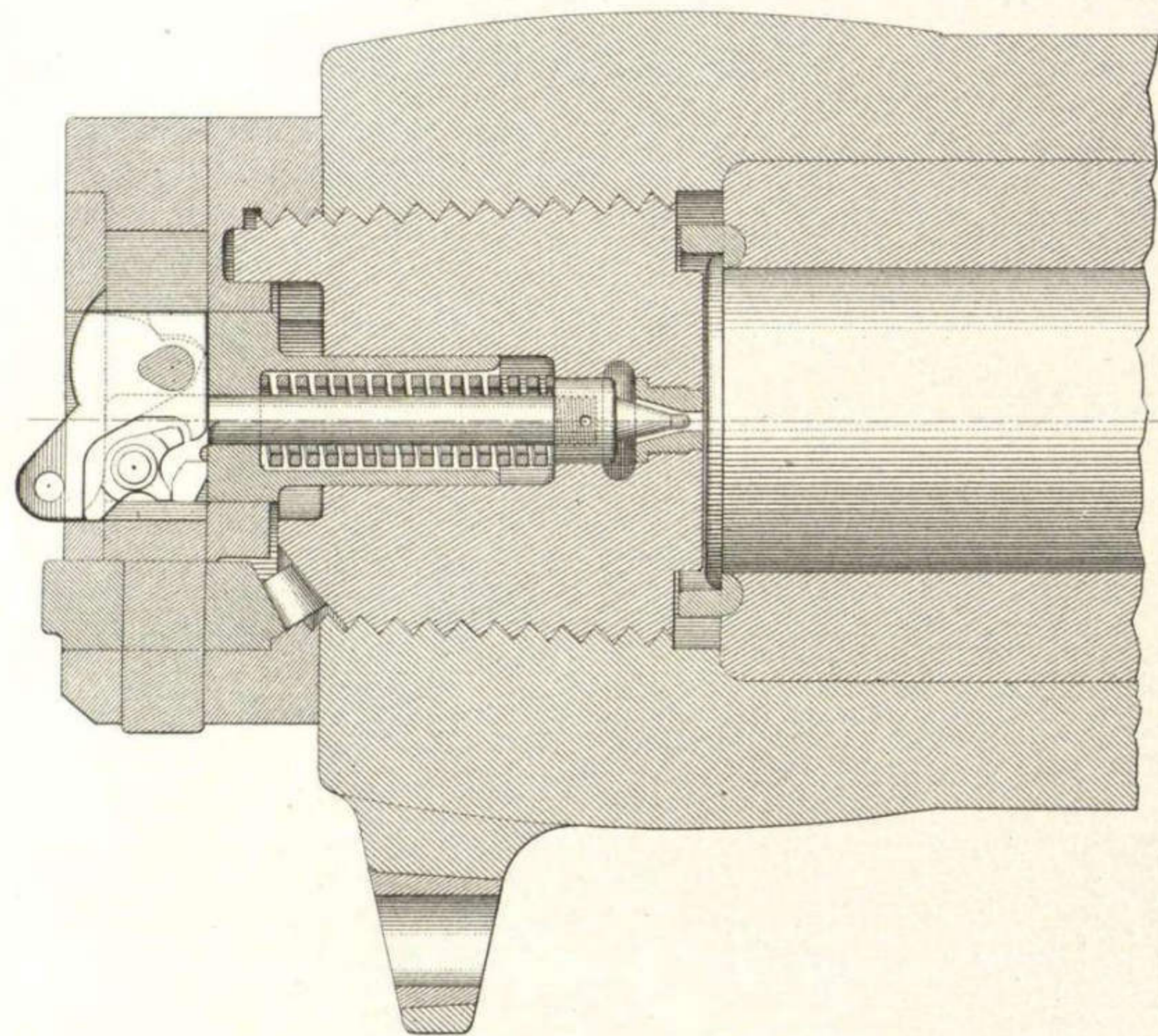

CAÑON t. r. DE 75 mm. DE CAMPAÑA SAINT-CHAMOND. DETALLES

Escala $\frac{5}{10}$.

Tornillo del cierre.
Acero.

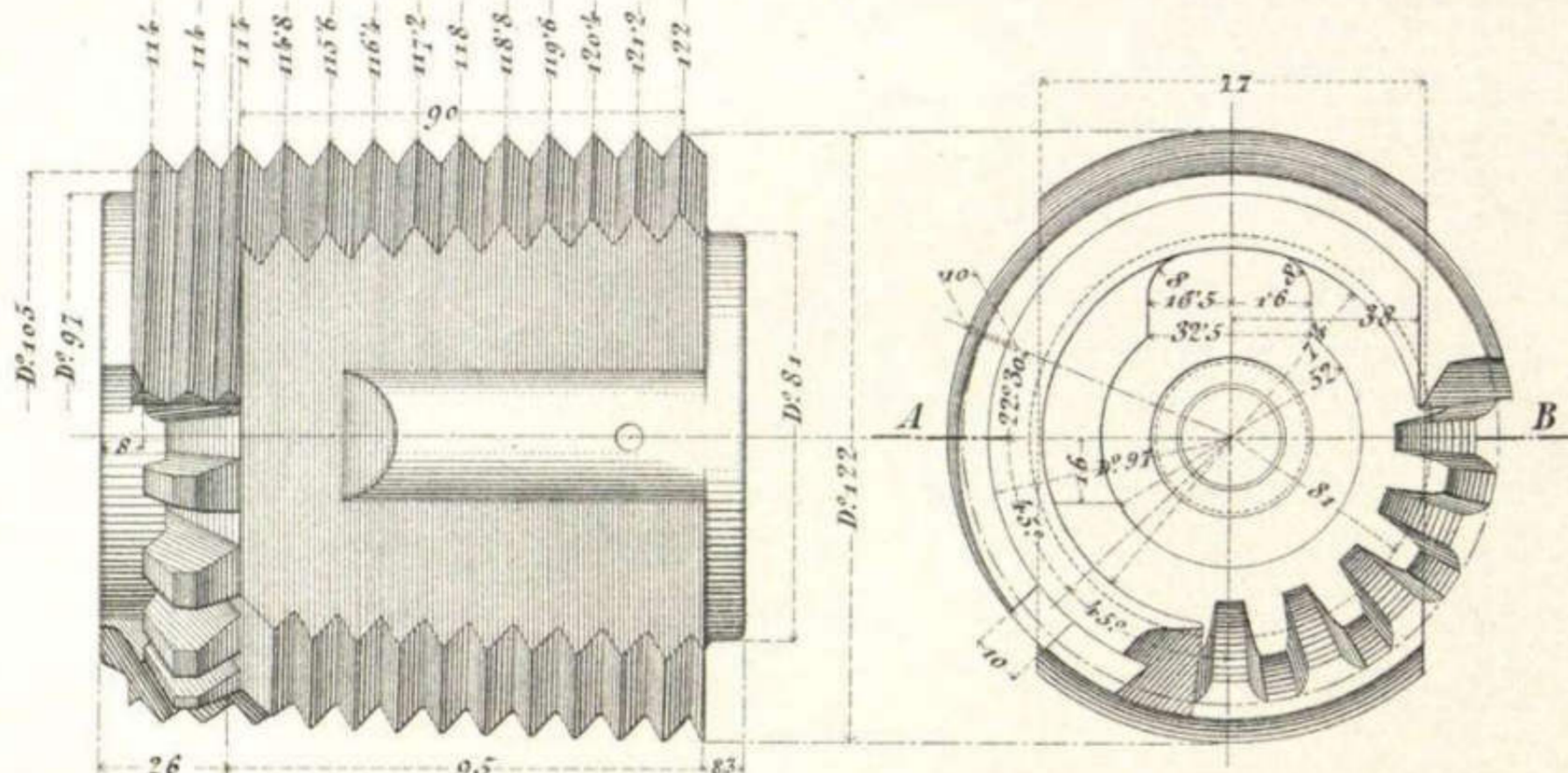

Eje de la palanca del cierre.
Acero.

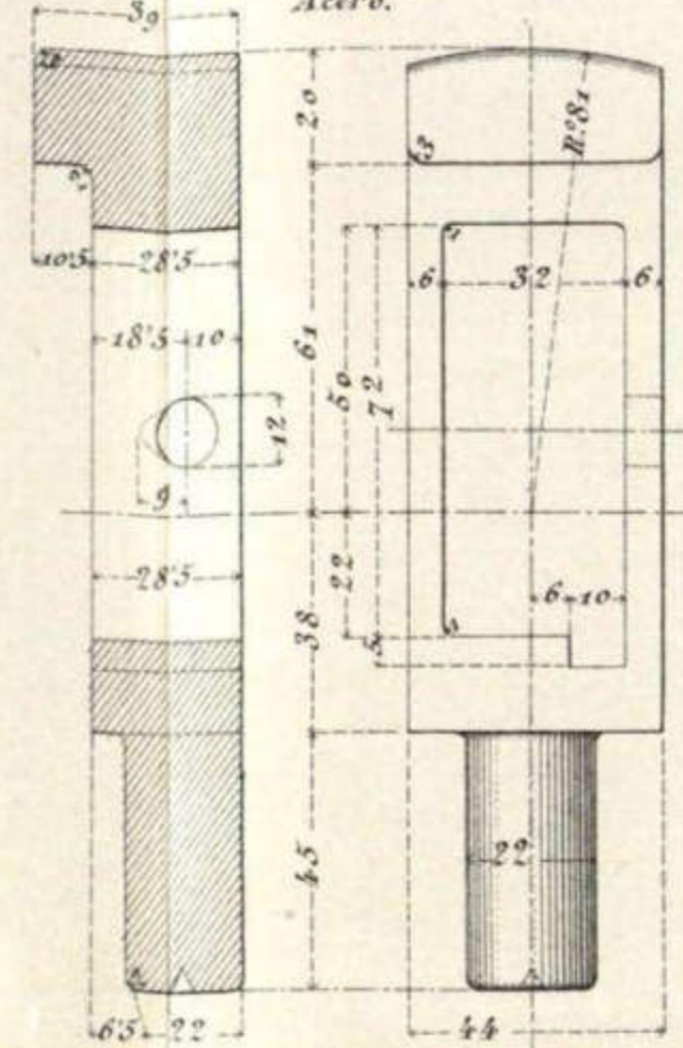

Porta-cierre.
Acero.

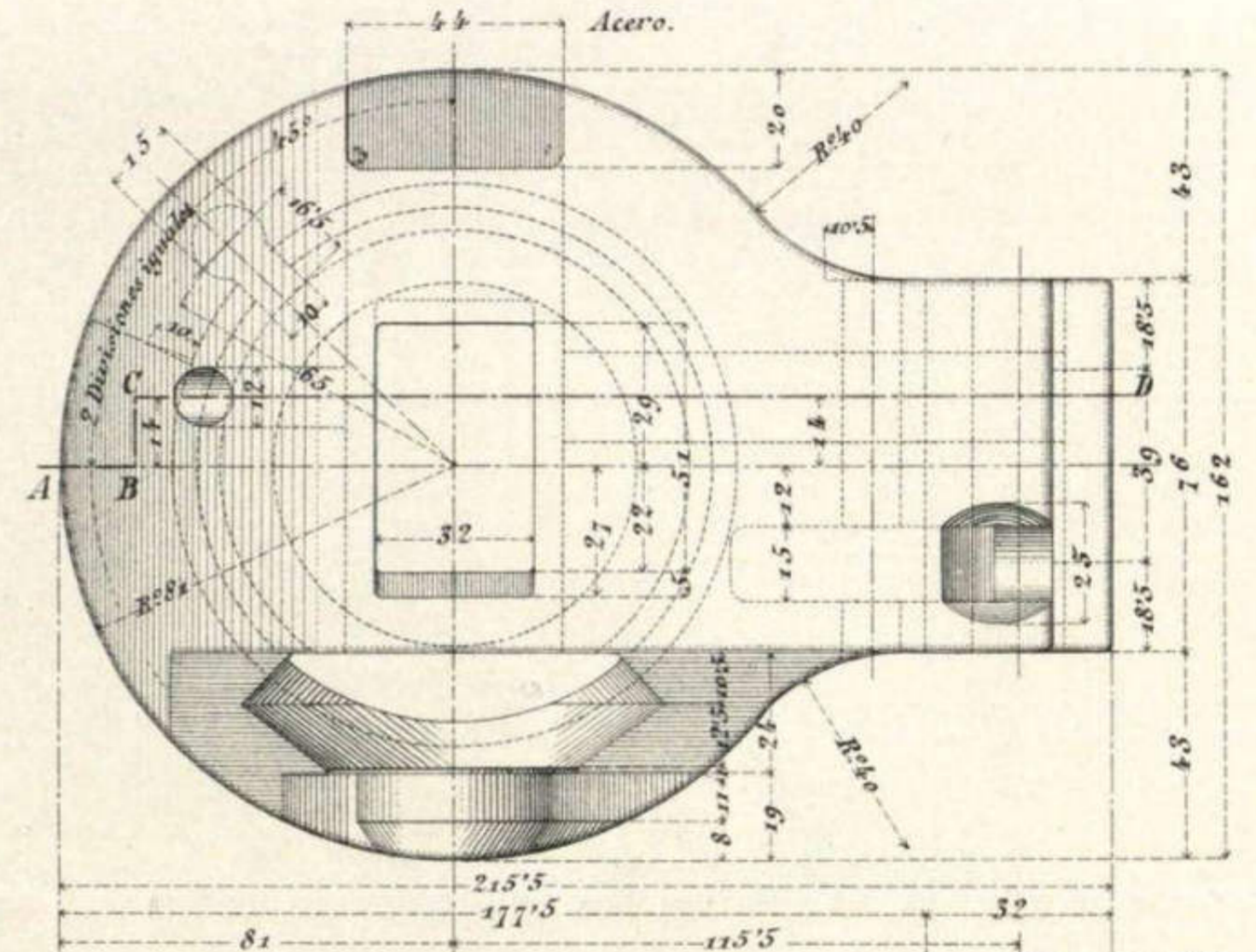

Sección A.B.

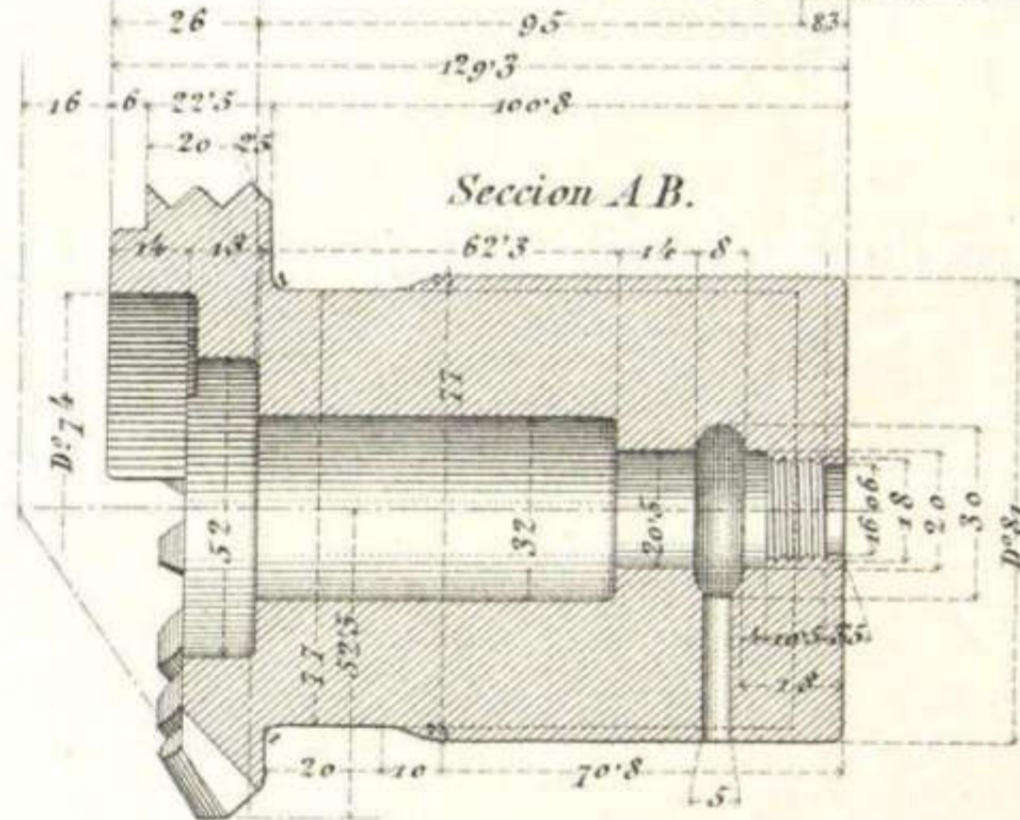

Eje de giro del porta-cierre.
Acero.



Palanca del cierre.
Acero.

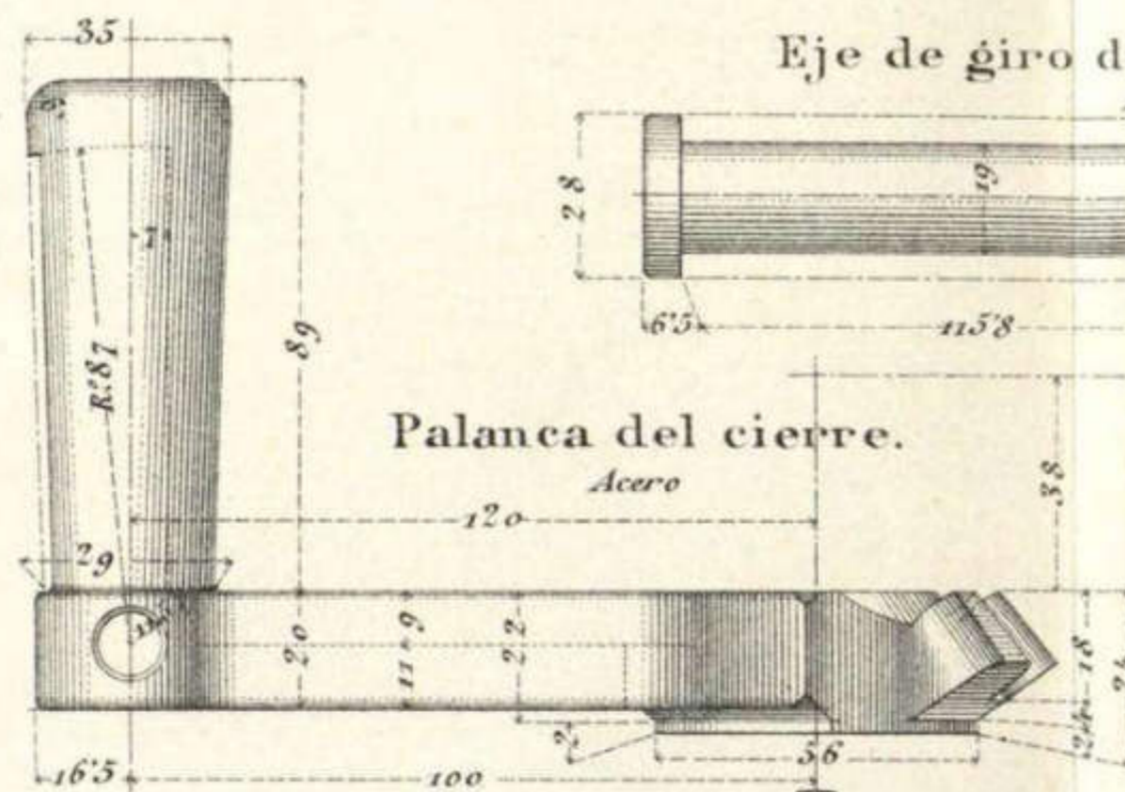

Grano.

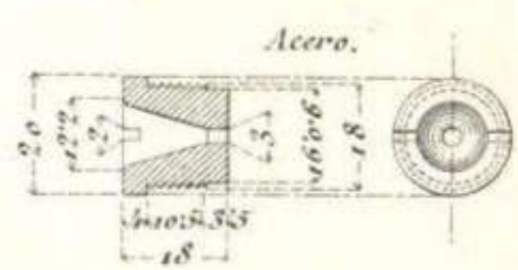

Eje pasador.
Acero.



Fiador de la palanca del cierre.

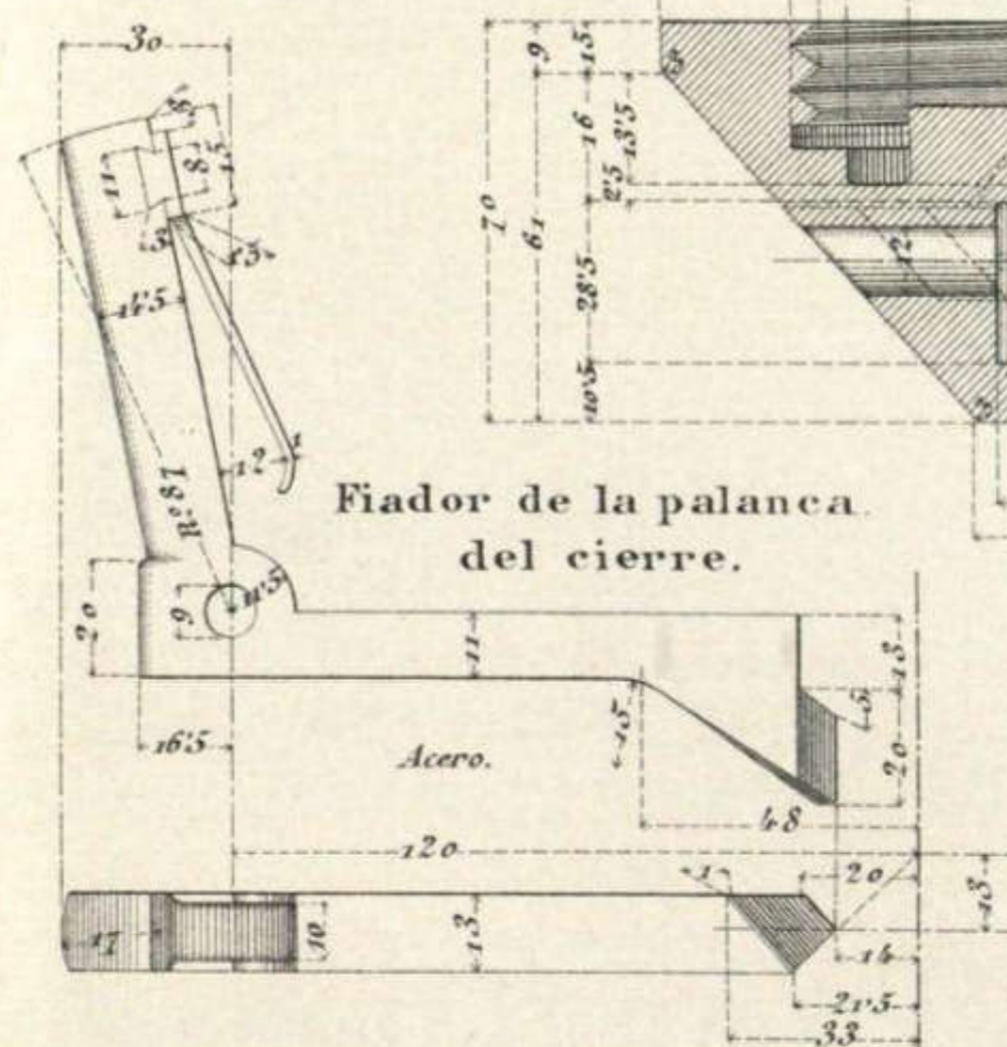

Pestillo.
Acero.

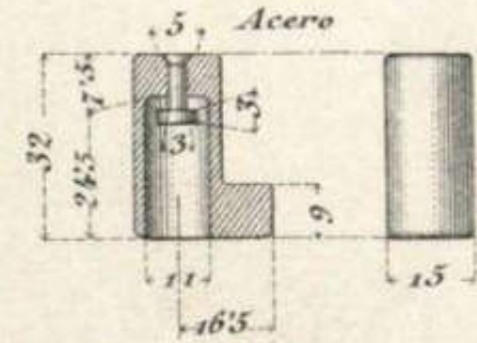

Muelle.
Acero.

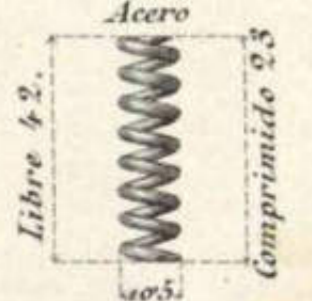

CUREÑA PARA CAÑÓN t. r. DE 75 mm. DE CAMPAÑA SAINT-CHAMOND

CUERPO DE LA CUREÑA

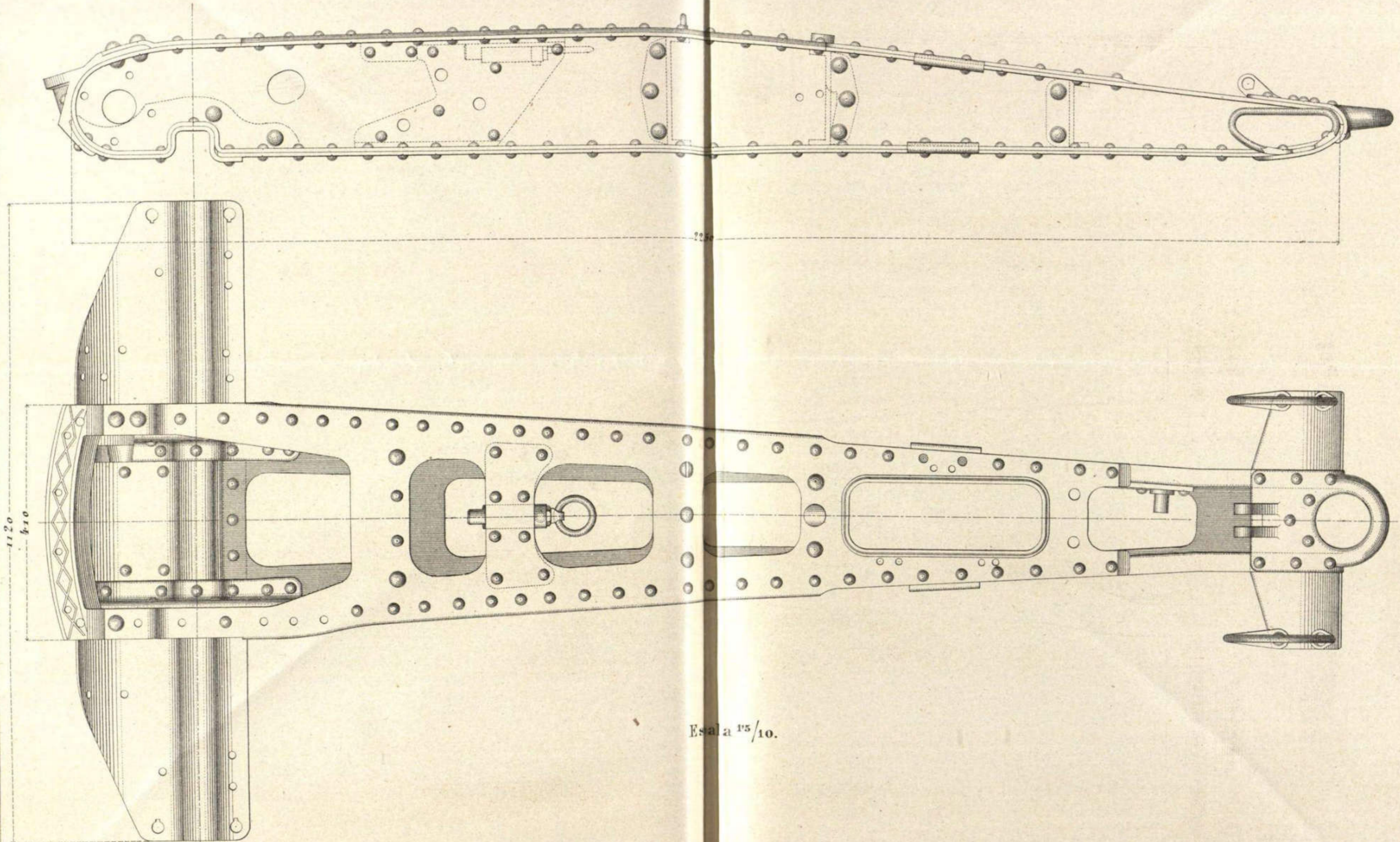

Escala 1⁵/10.

CUREÑA PARA CAÑÓN t. r. DE 75 mm. DE CAMPAÑA SAINT-CHAMOND

DETALLES.

Cerrojo para ligar el cañón y cureña en las marchas. (E = 1/10)

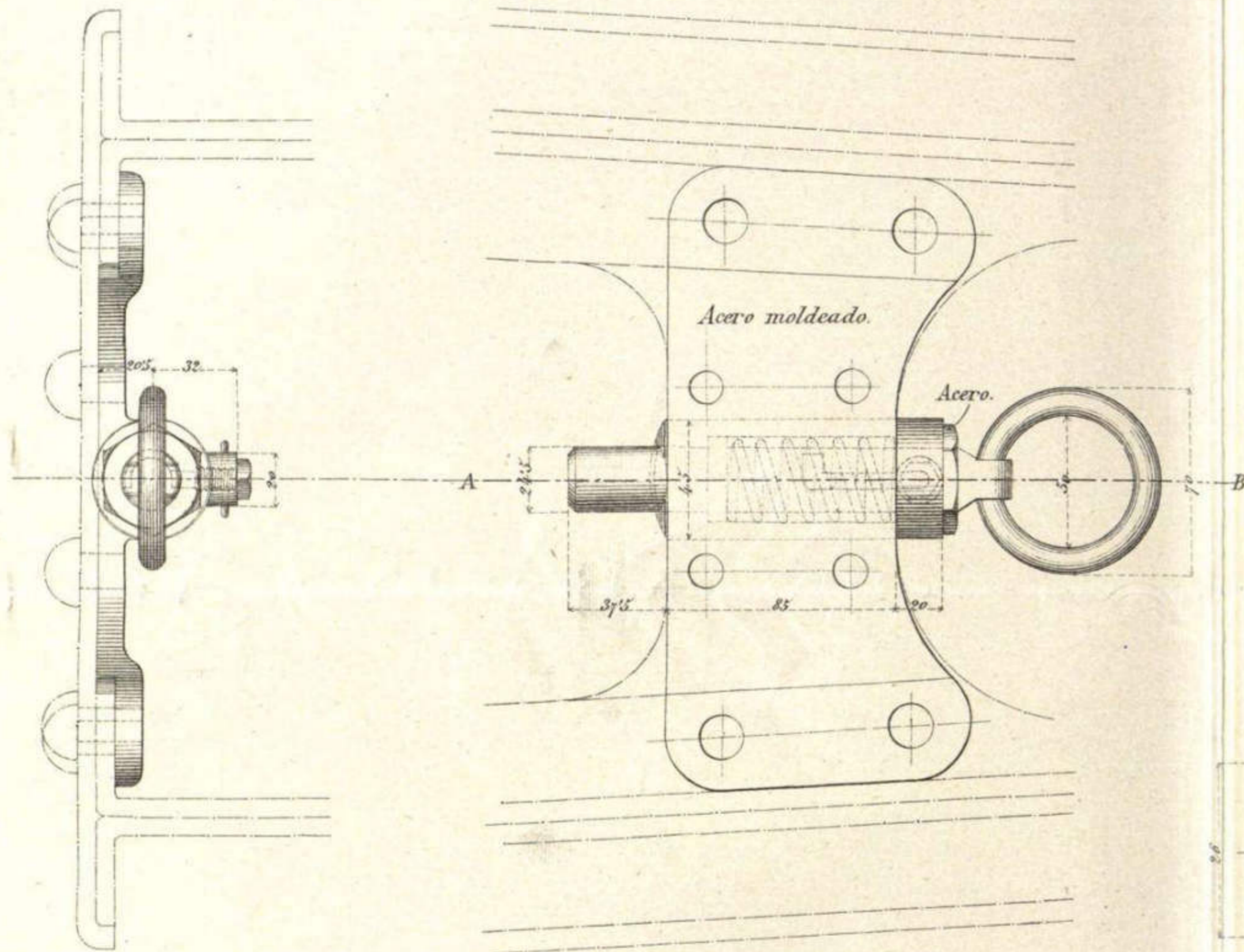

Sección por AB.

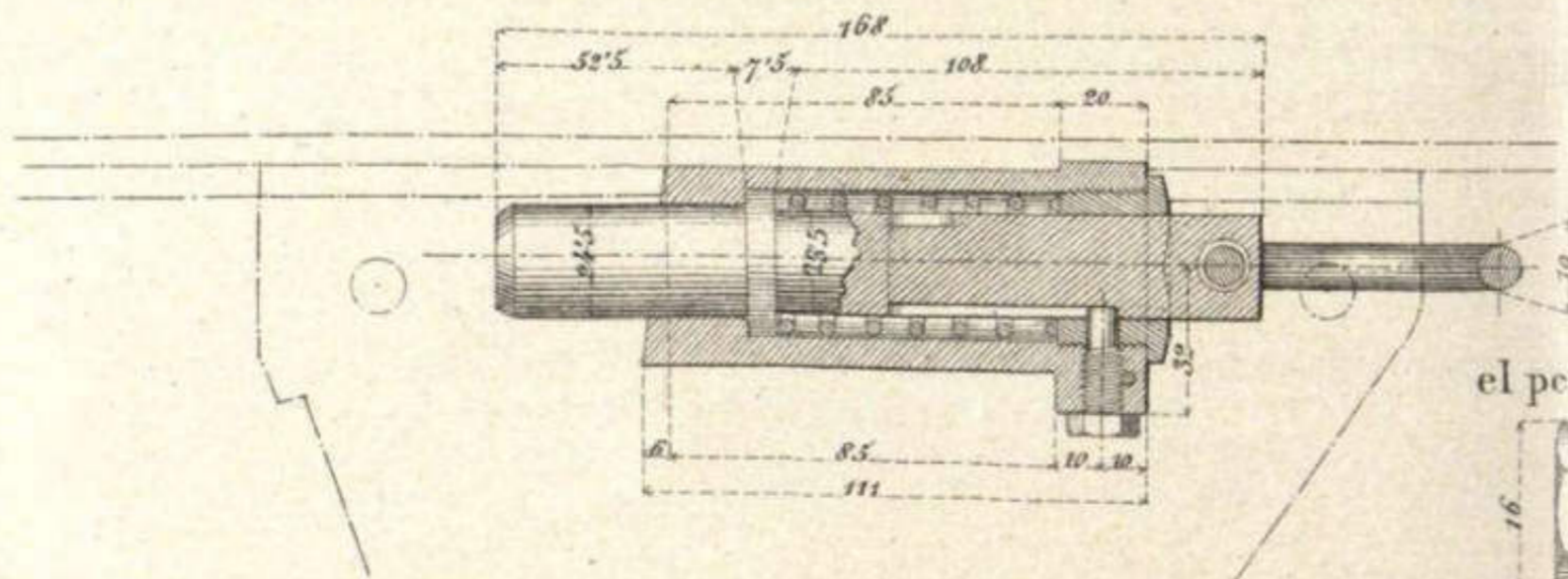

Tope-pestillo del cerrojo (1/1)

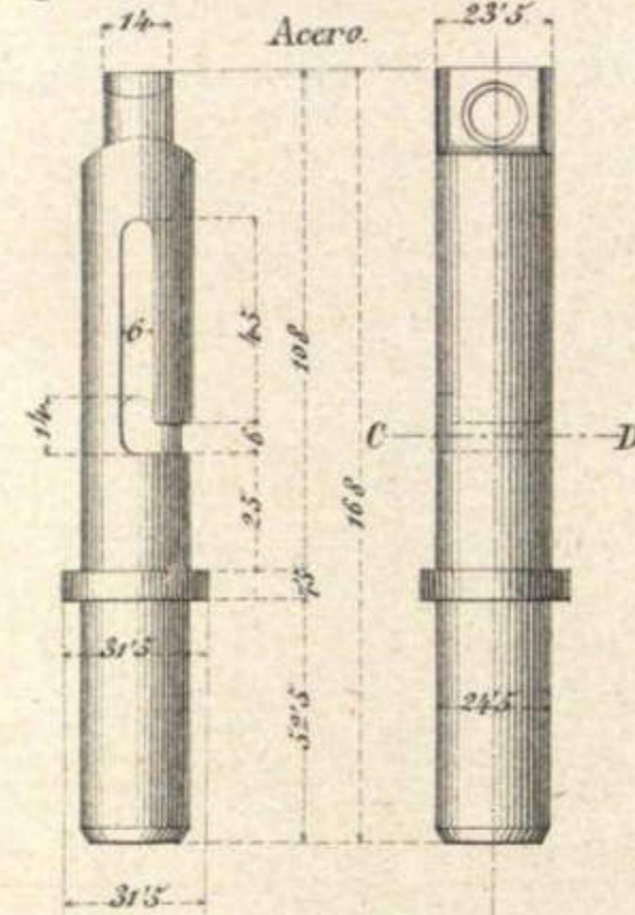

Sección por C.D.

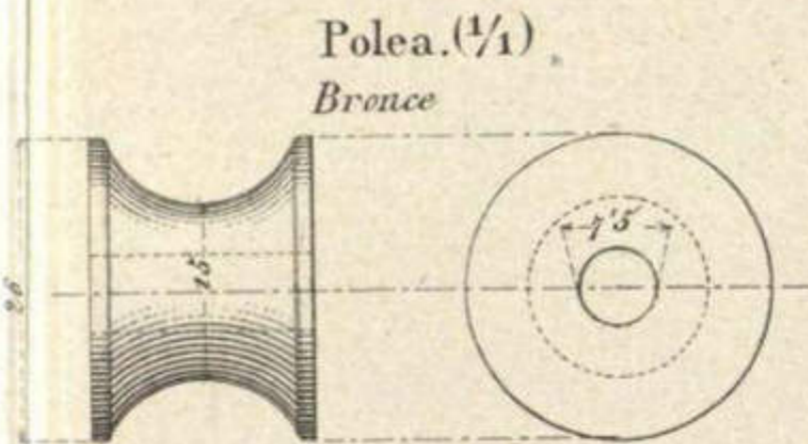

Eje de la polea (1/1)

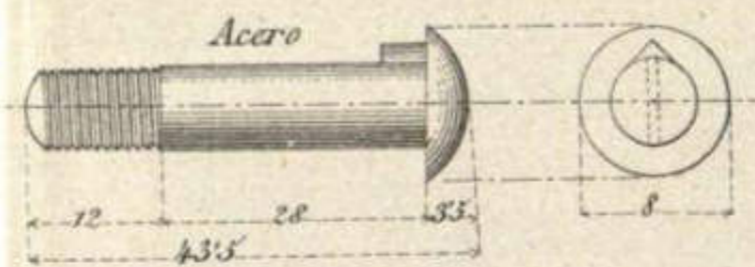

Tope para el pestillo del cerrojo (1/1)

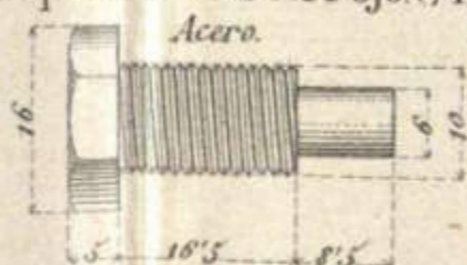

Muelle helicoidal para el cerrojo (1/10)



Polea para el cambio de dirección de la cuerda disparadora. (1/1)

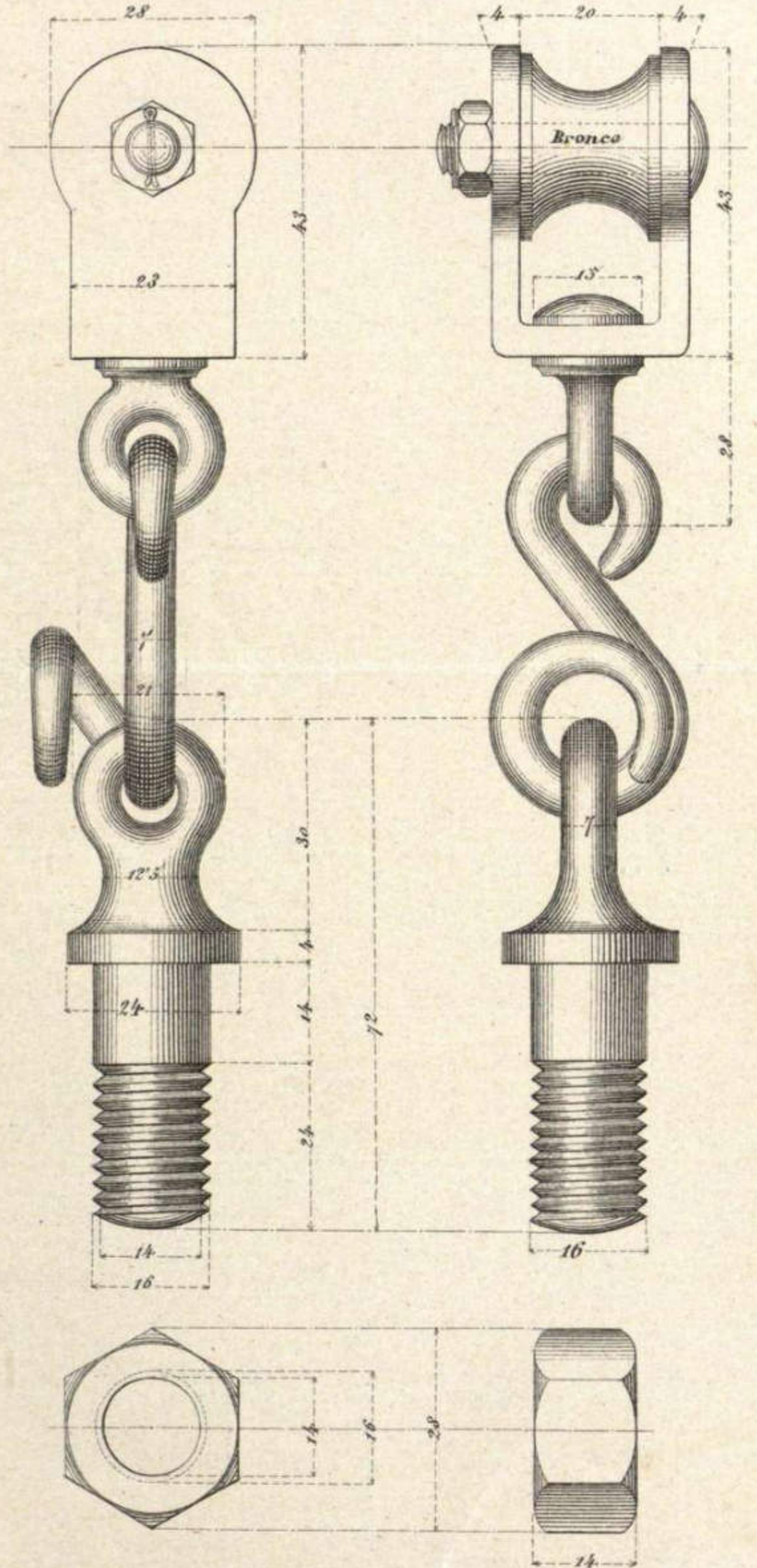

CUREÑA PARA CAÑON t. r. DE 75 mm. DE CAMPAÑA SAINT-CHAMOND

DETALLES.

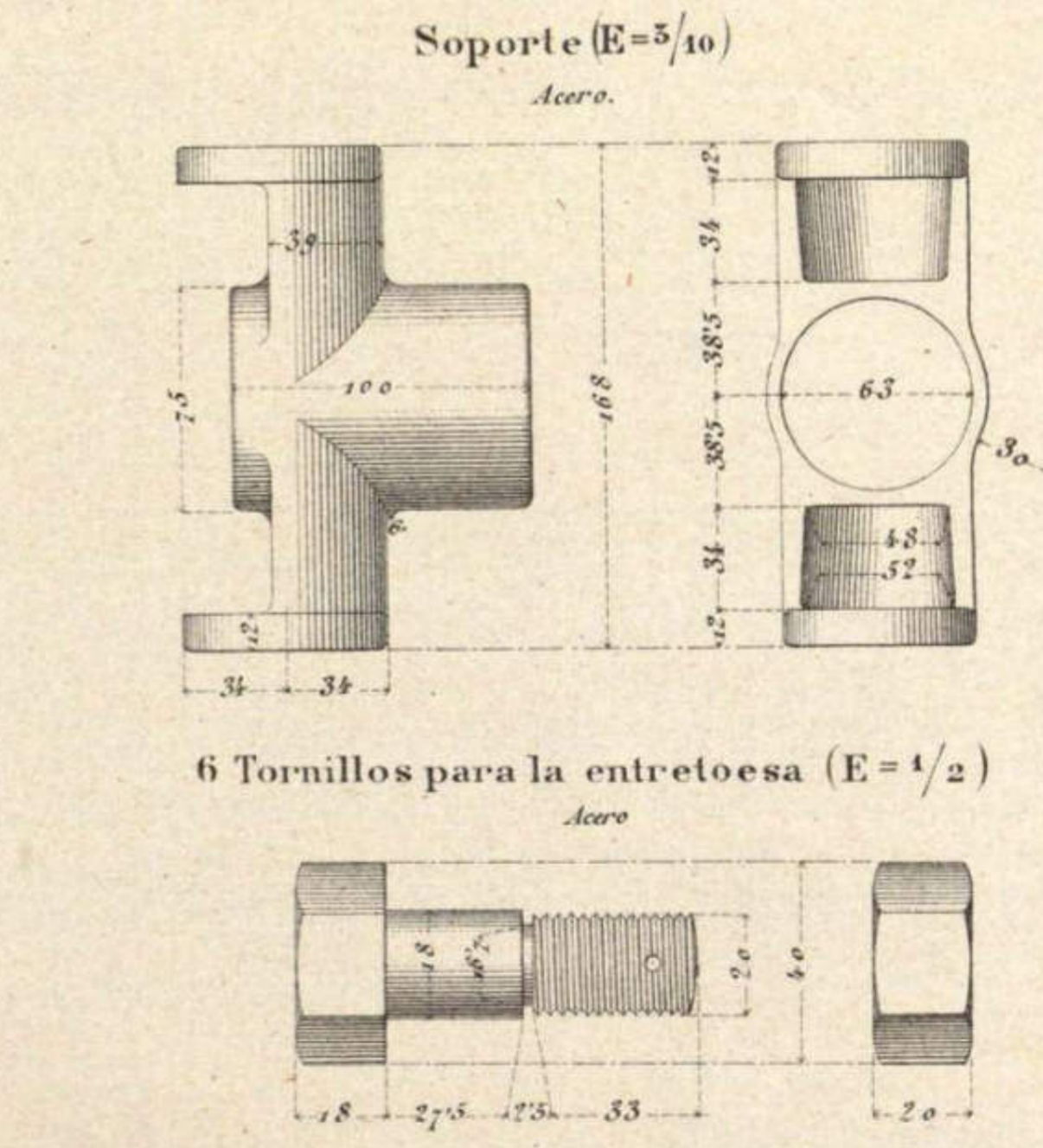
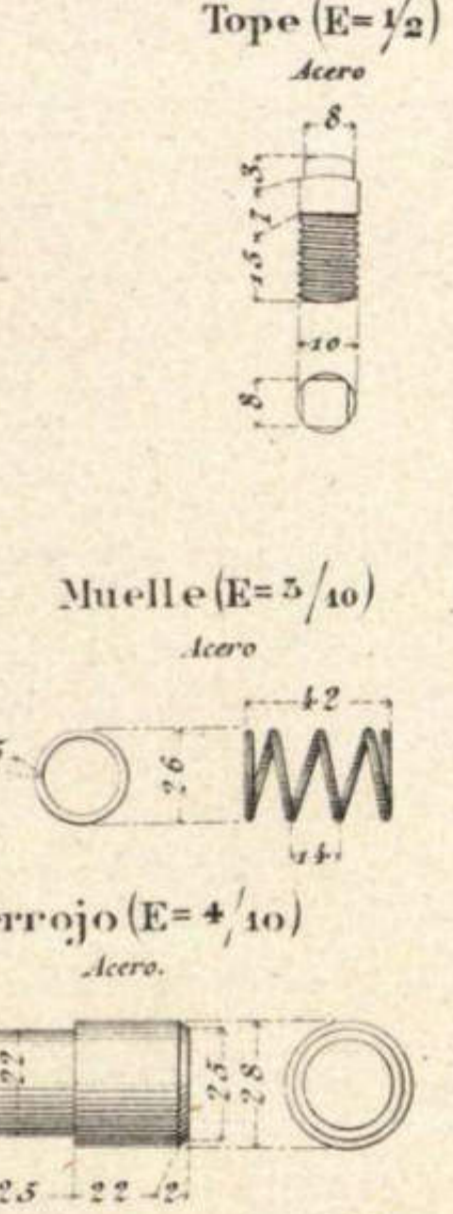
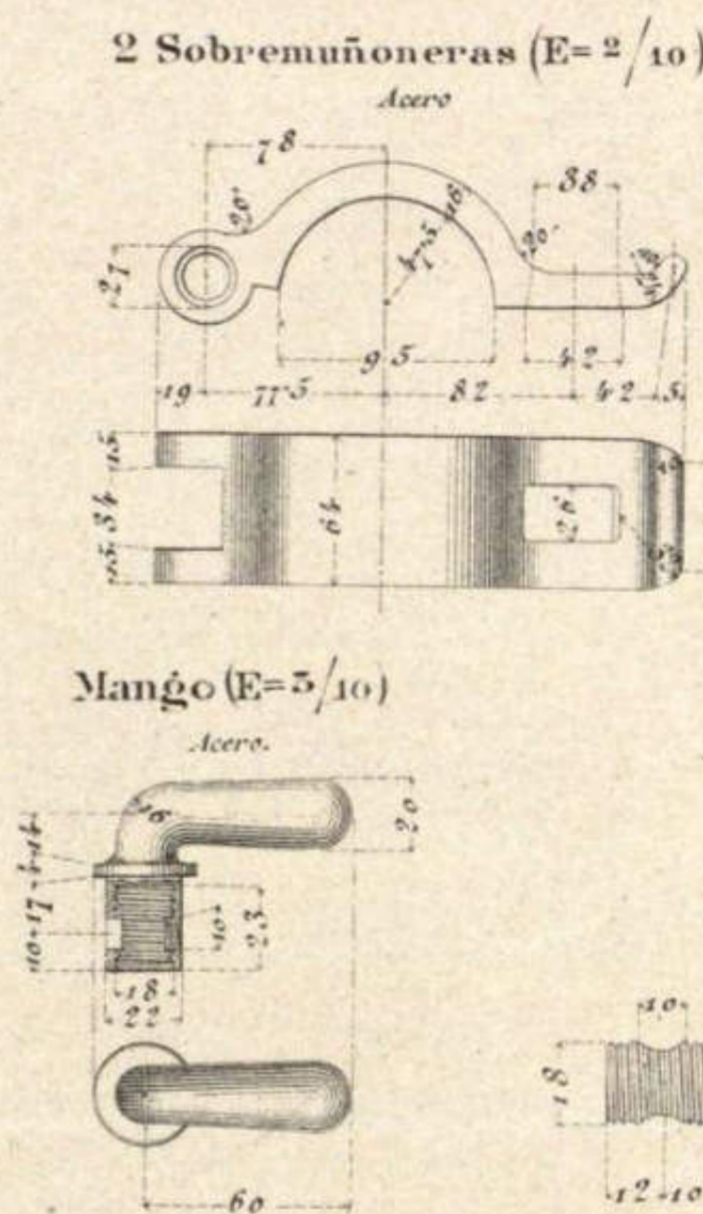
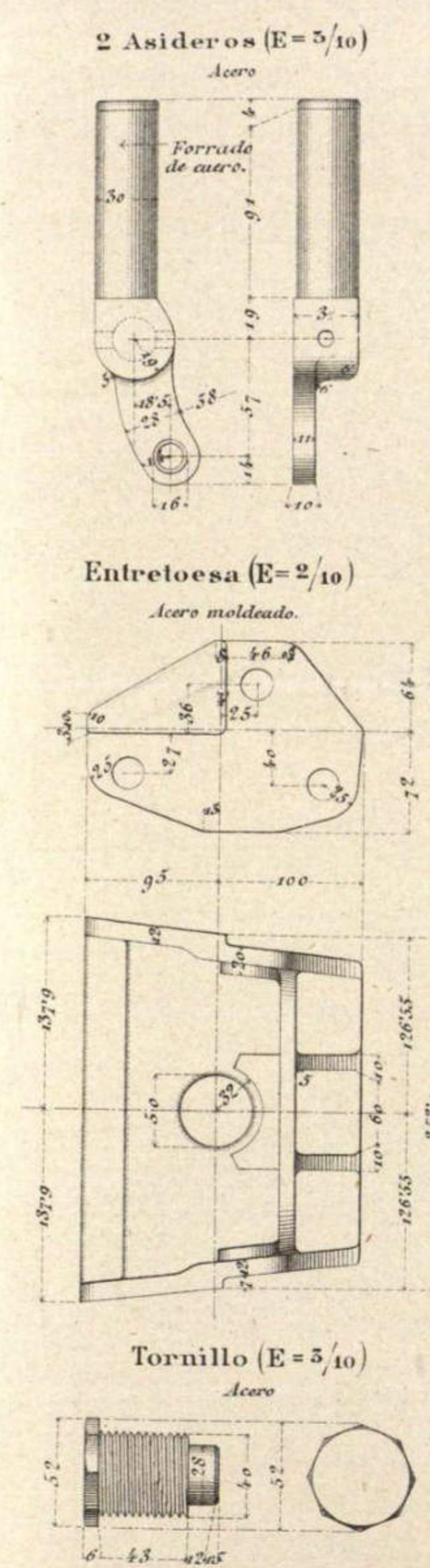
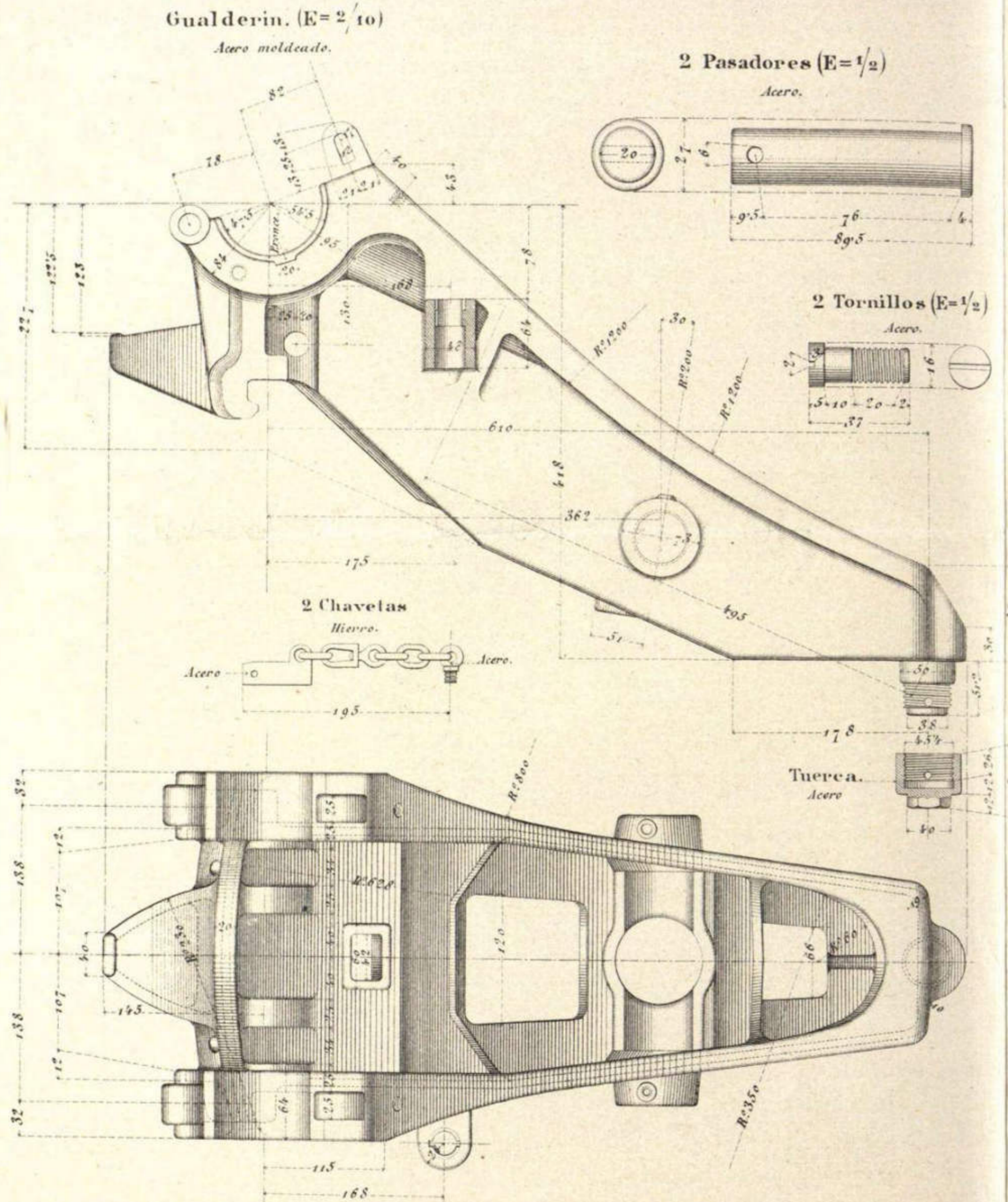

CUREÑA PARA CAÑÓN t. r. DE 75 mm. DE CAMPAÑA SAINT-CHAMOND
APARATO DE PUNTERIA EN ALTURA

Escala 5/10

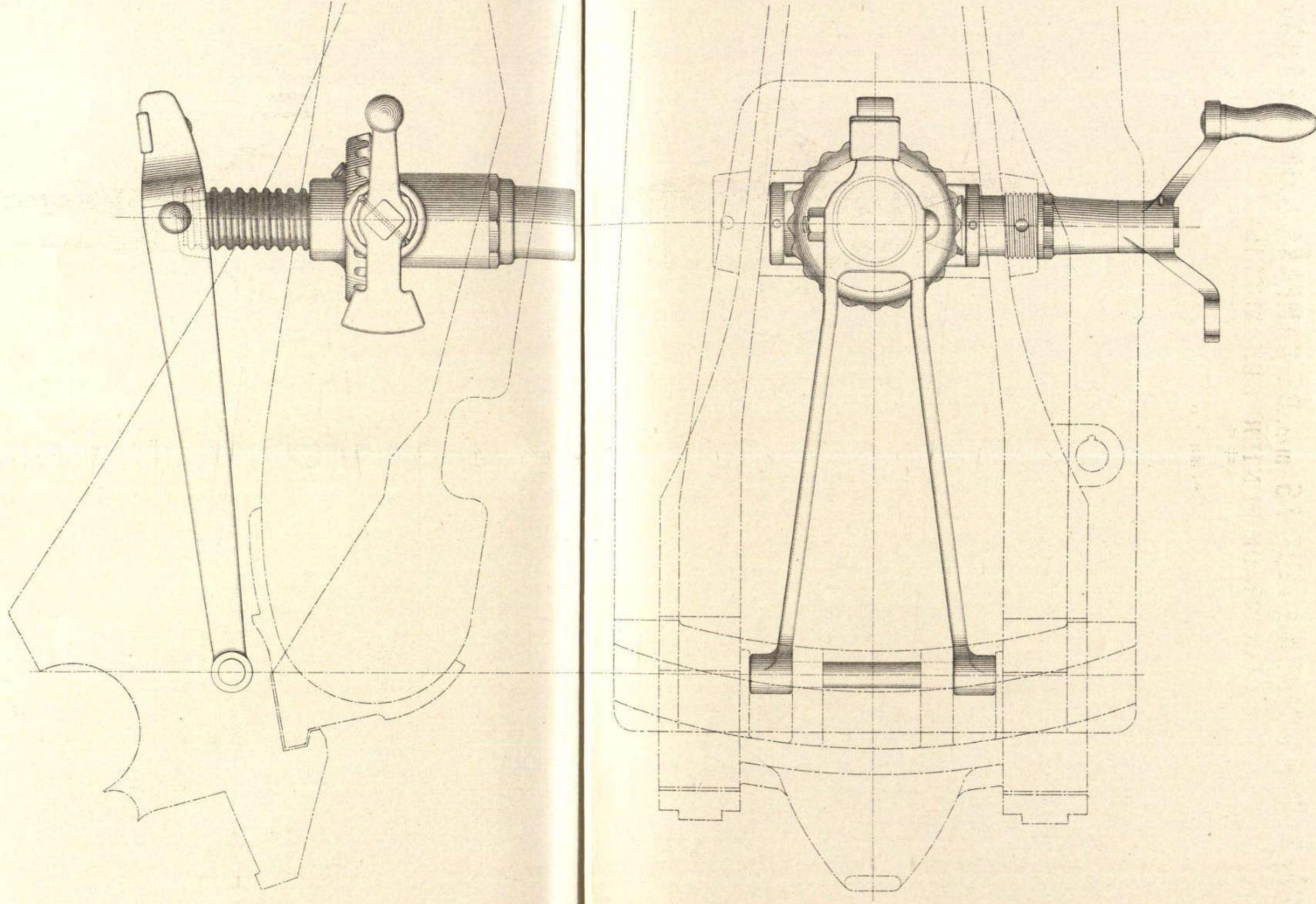

CUREÑA PARA CAÑÓN t. r. DE 75 mm. DE CAMPAÑA SAINT-CHAMOND

APARATO DE PUNTERIA EN DIRECCIÓN

Escala $\frac{5}{10}$

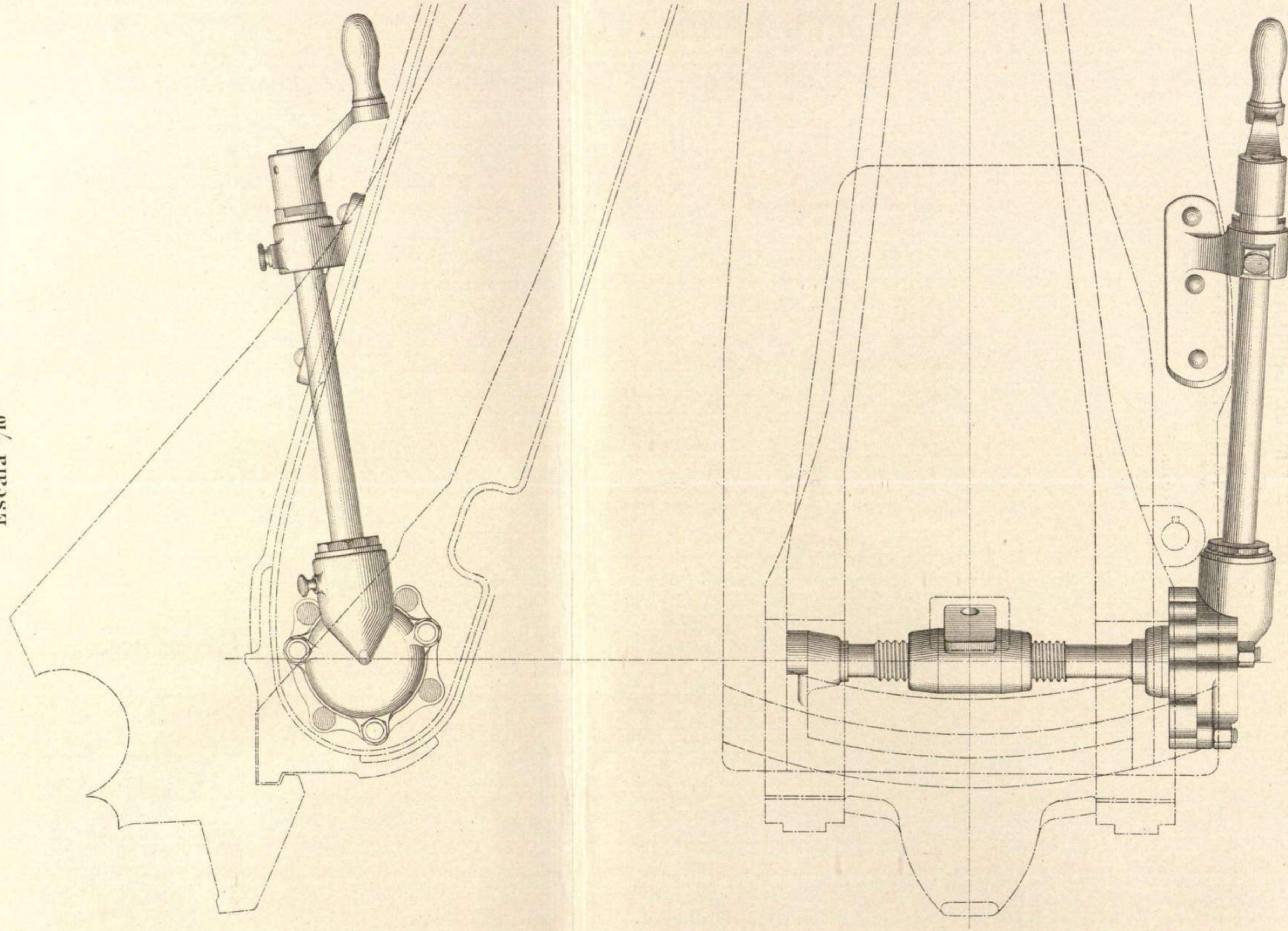

CUREÑA PARA CAÑÓN t.r. DE 75 mm. DE CAMPAÑA SAINT CHAMOND.

Soporte. (E. 5/10.)

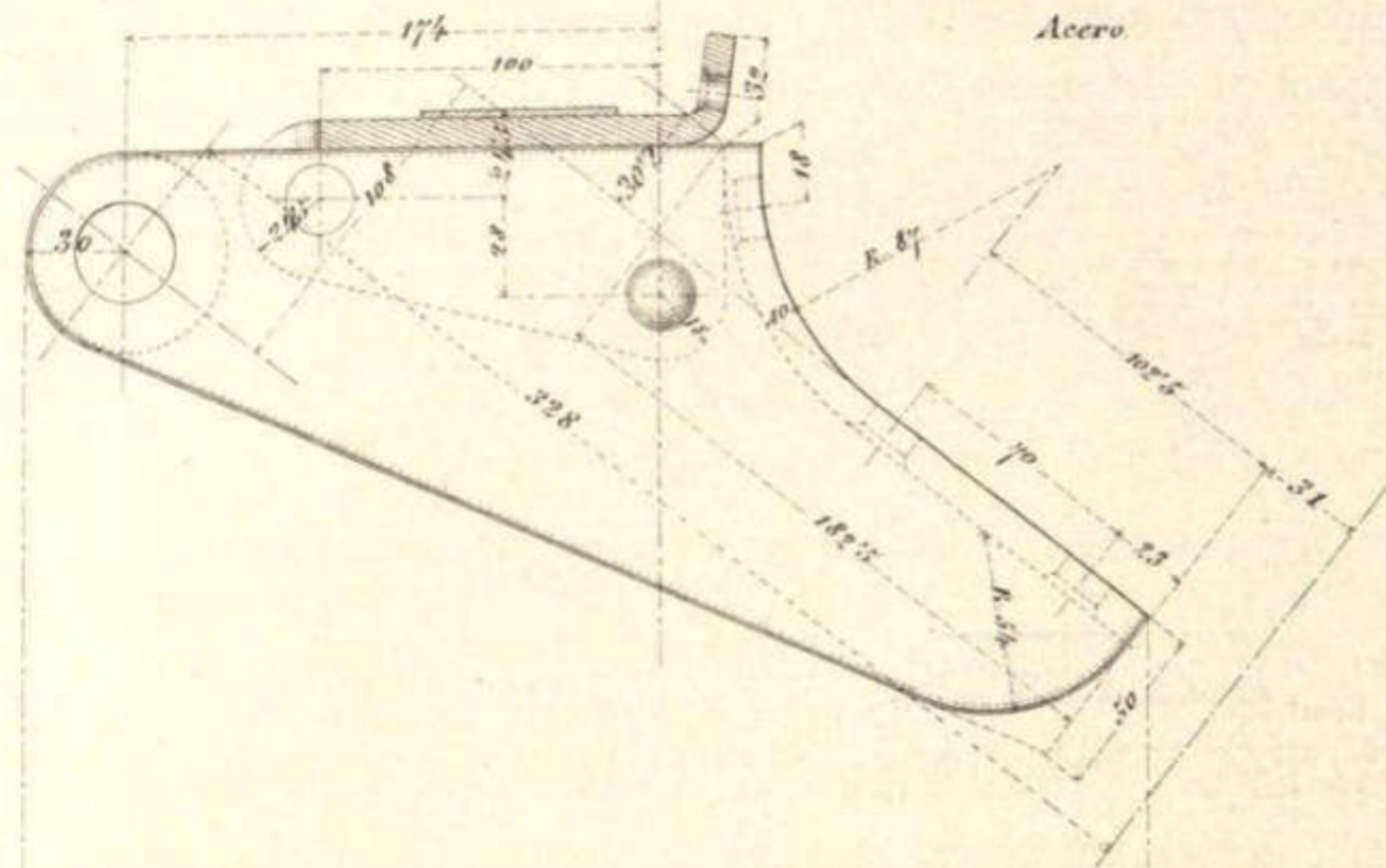

DETALLES.

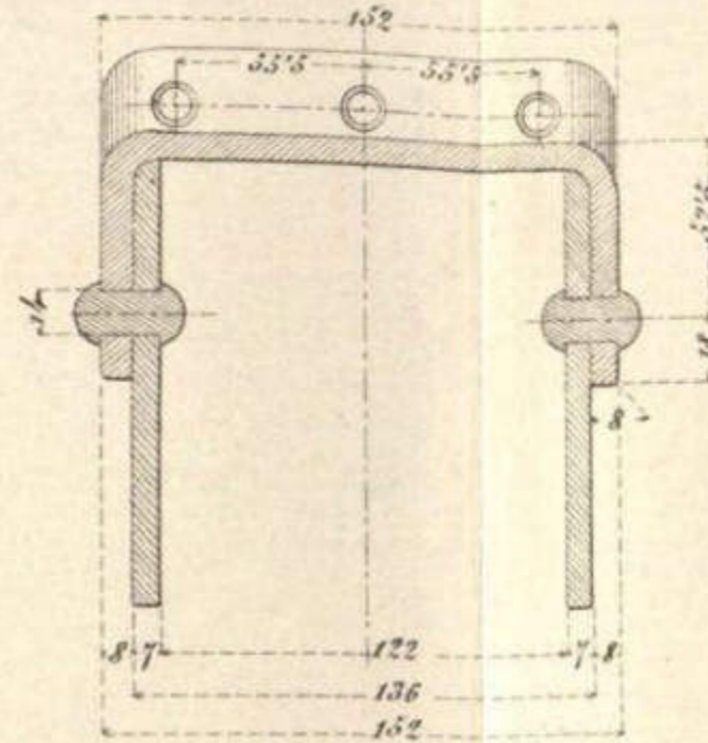

Collar oscilante. (E. 5/10.)

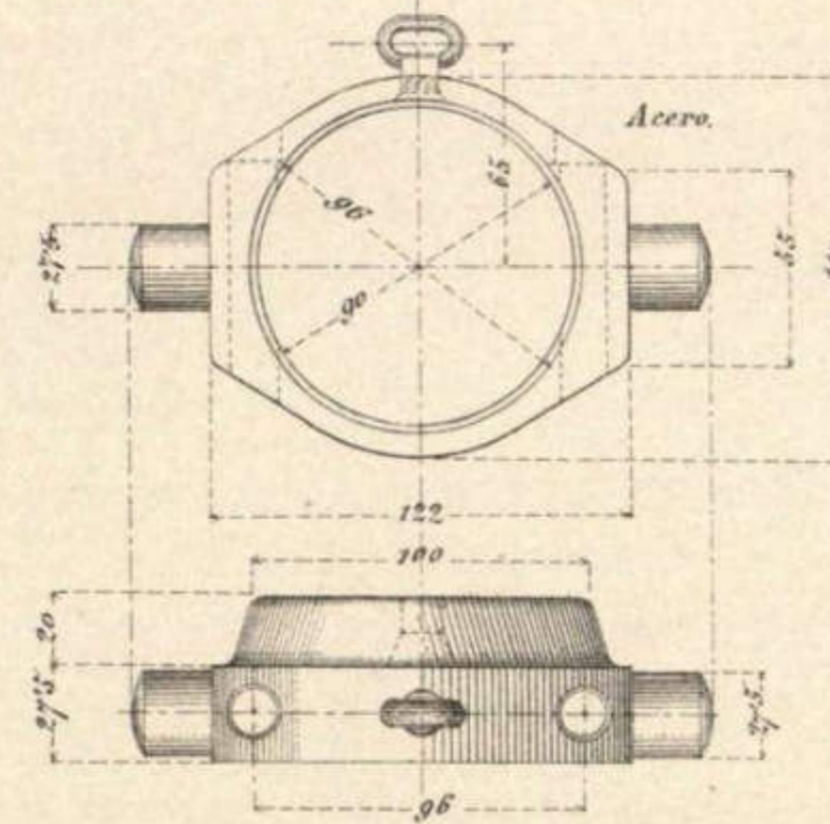

Pasadores. (E. 5/10.)

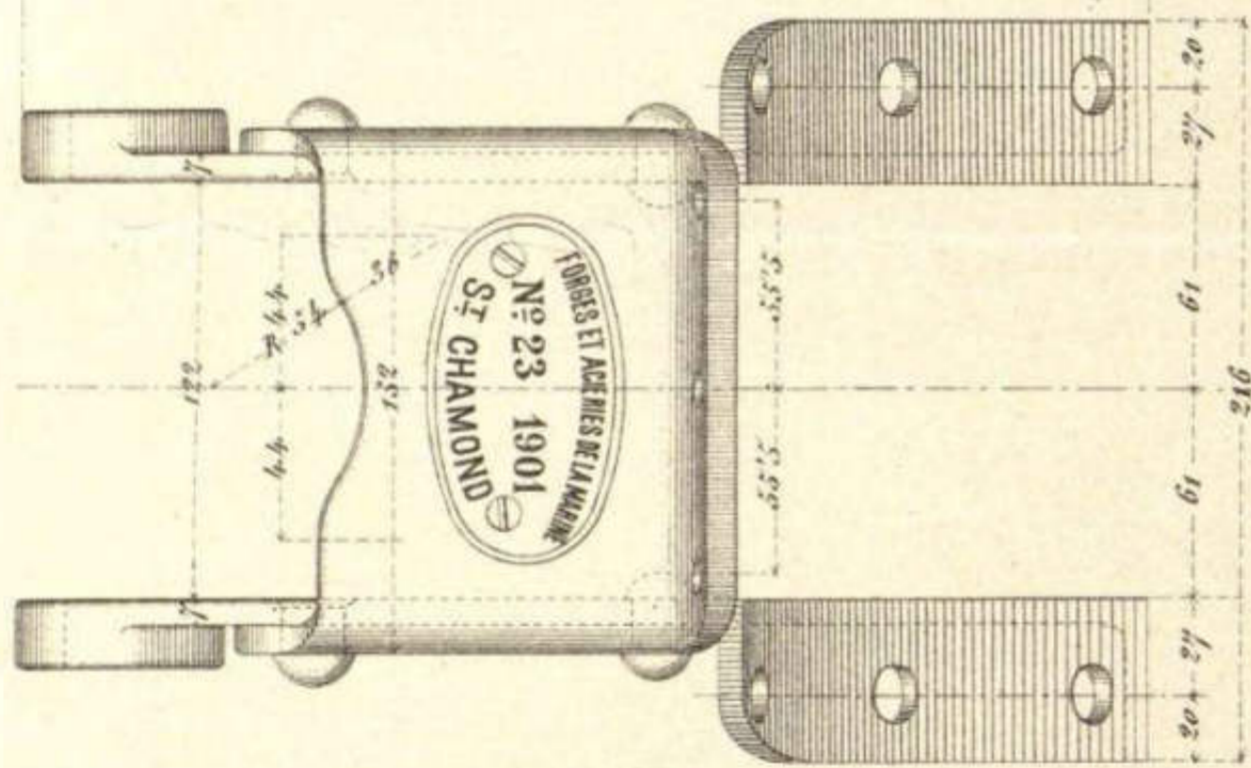
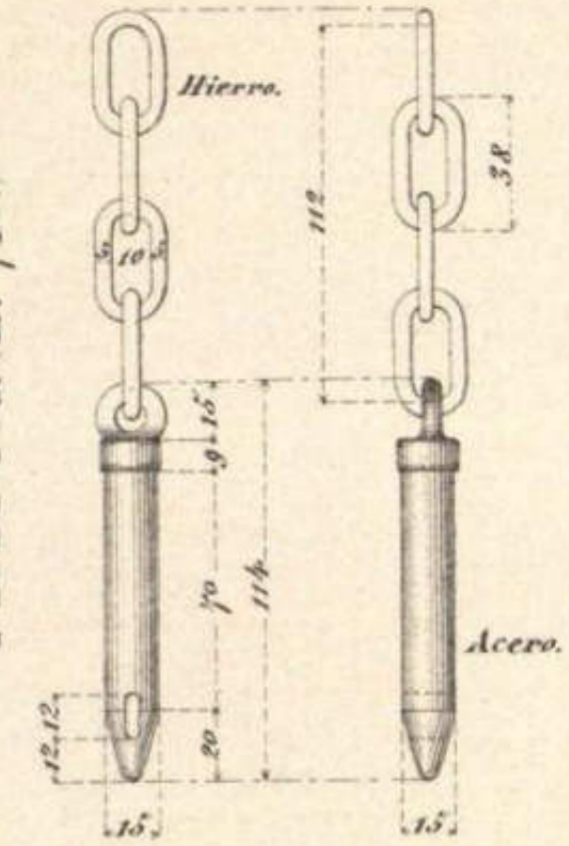

Cadena de suspensión. (E. 2/10.)

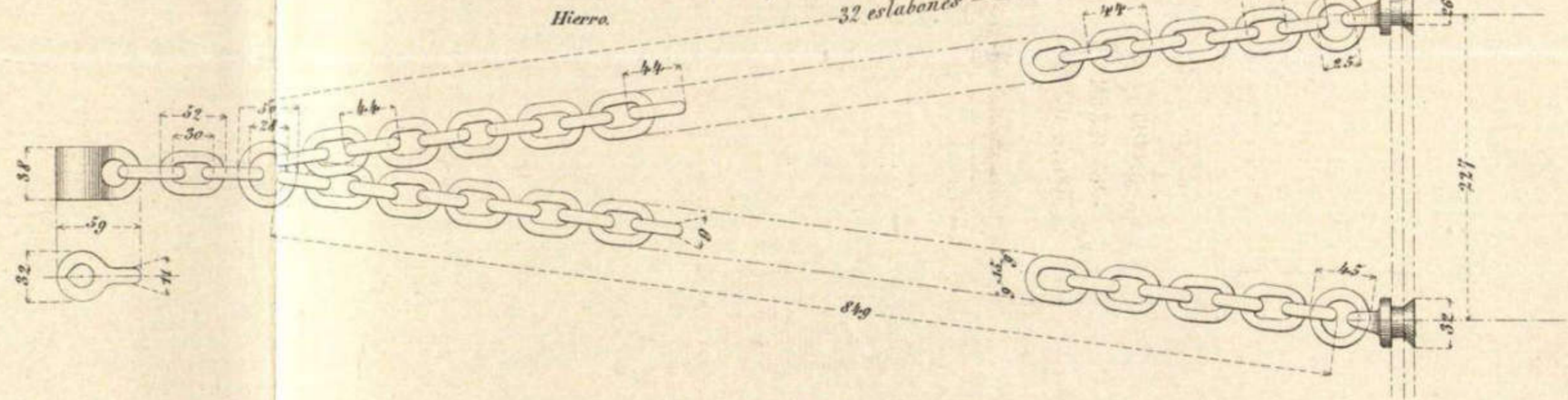

Arado. (E. 2/10.)

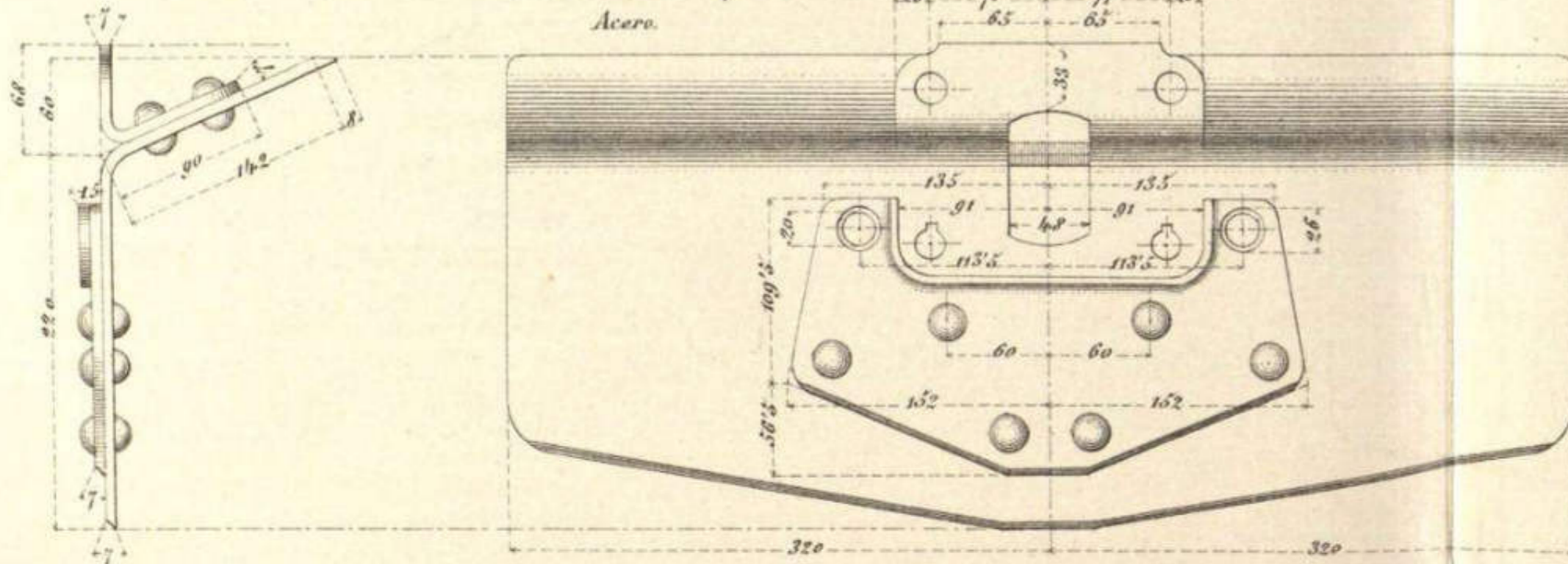

(E. 2/10.)

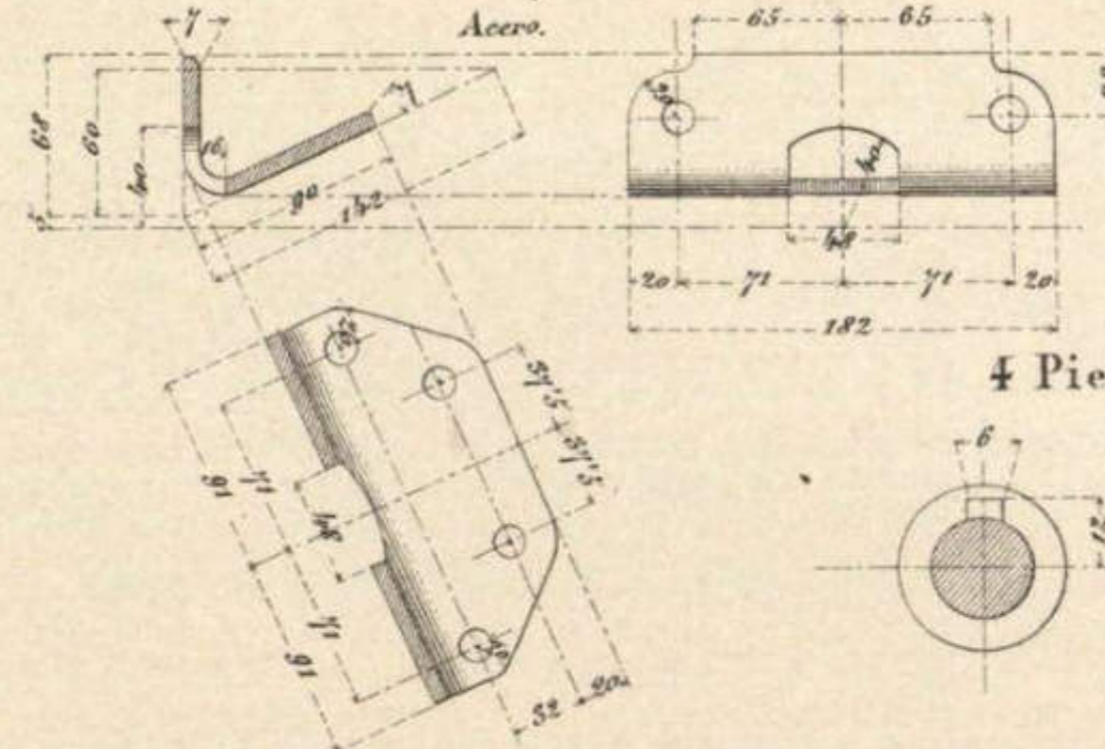

4 Piezas. (E. 5/10.)

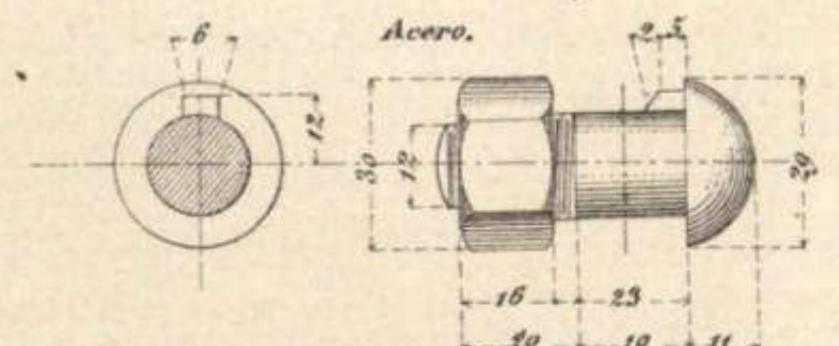

CUREÑA PARA CAÑON t.r. DE 75 mm. DE CAMPAÑA SAINT CHAMOND.

FRENO DE MARCHA

Soportes. (2 piezas) 4/10.
Acero.

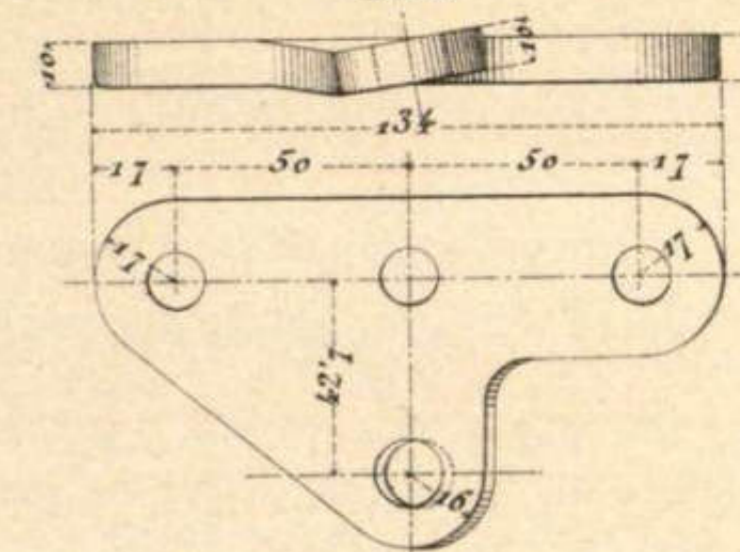

Chaveta de cadenilla. (2 piezas) E = 4/10.

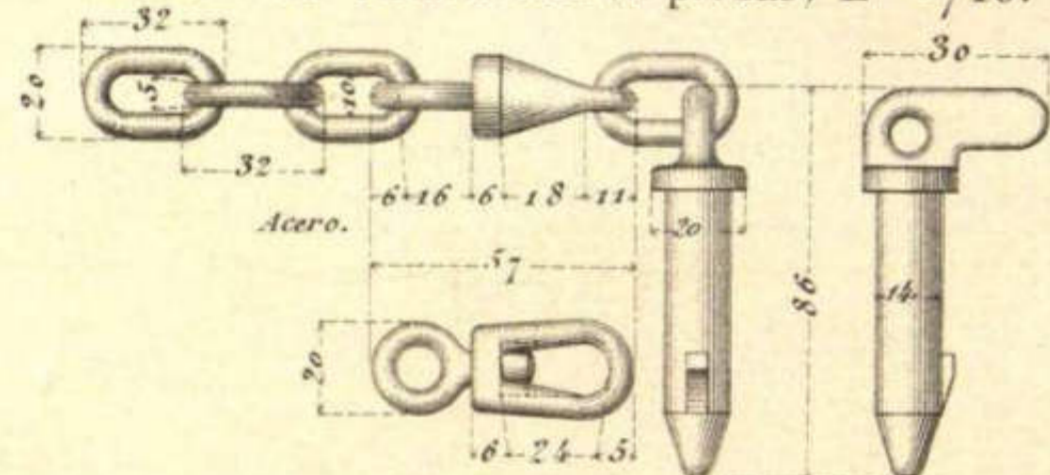

Soportes. (2 piezas) 4/10

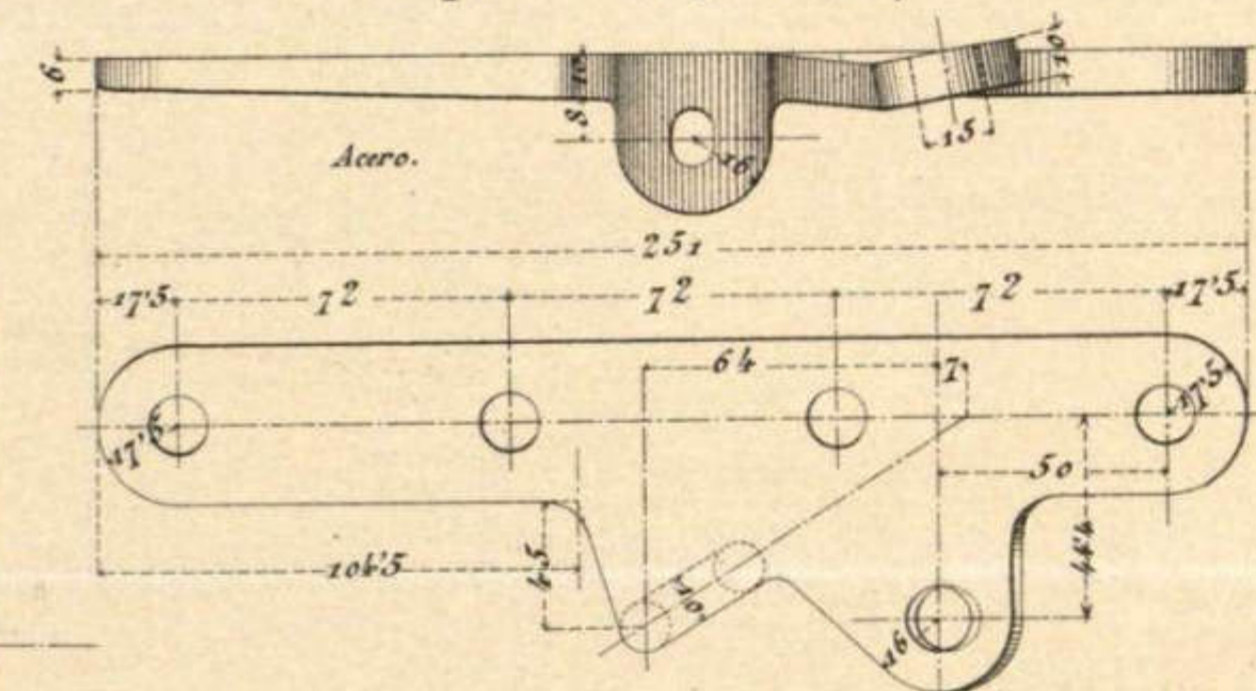

Soporte (2 piezas) 4/10.

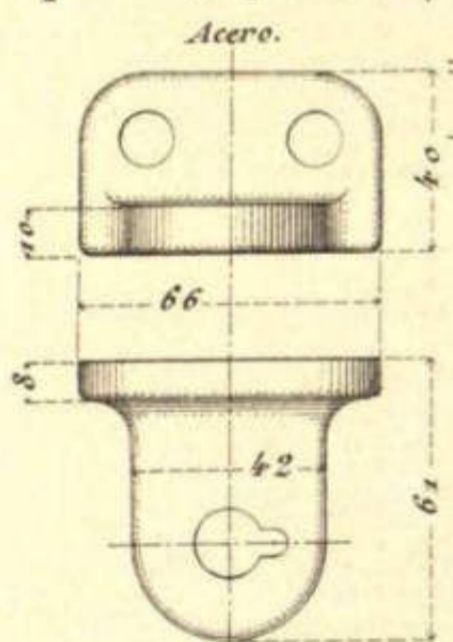

Soporte especial. (4/10)

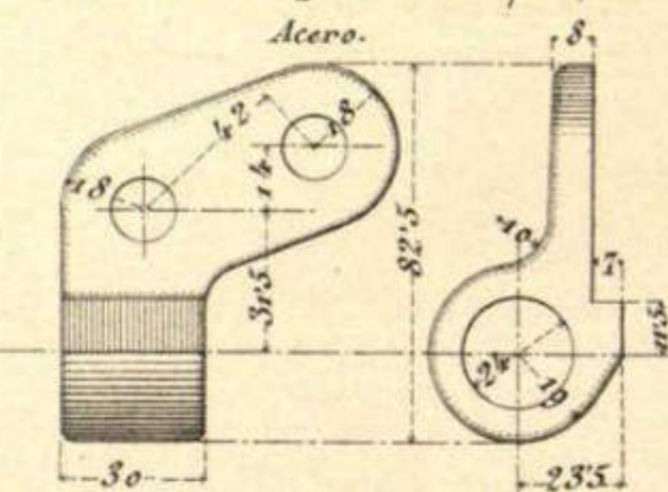

Escala 1,5/10

Soporte del husillo. (4/10)

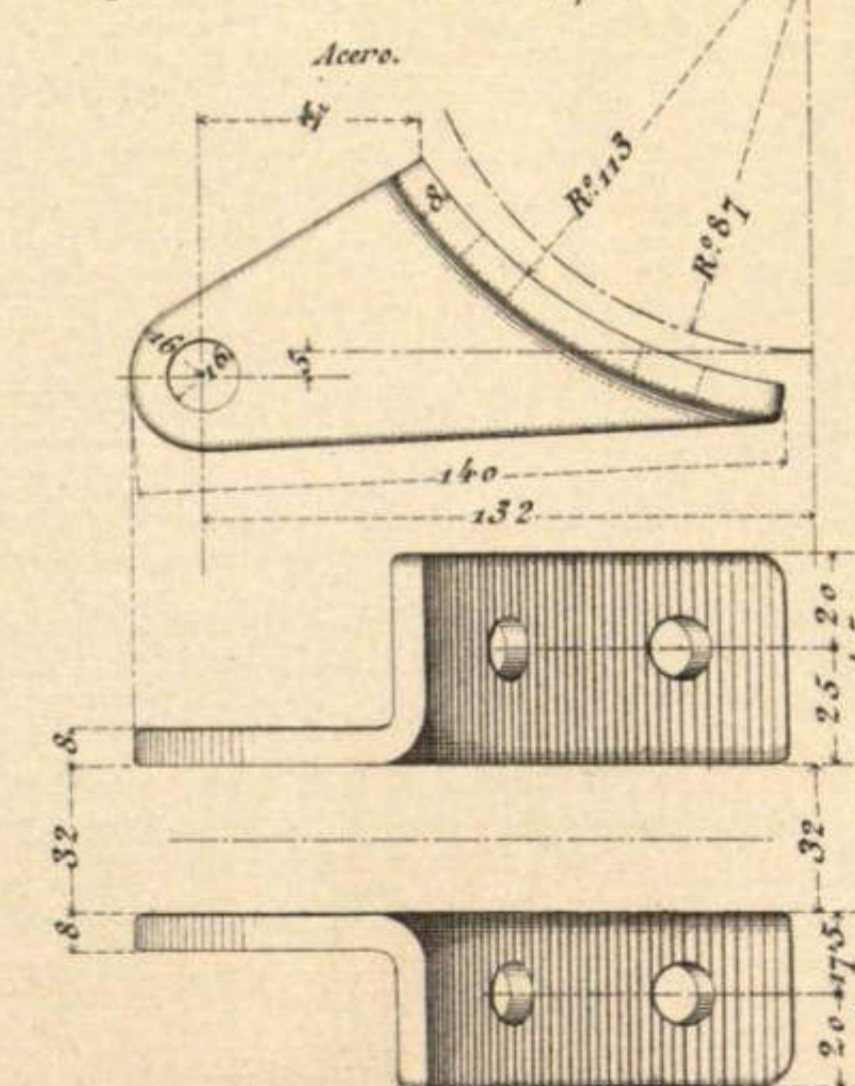

Gancho y péndola
2 piezas. (4/10)

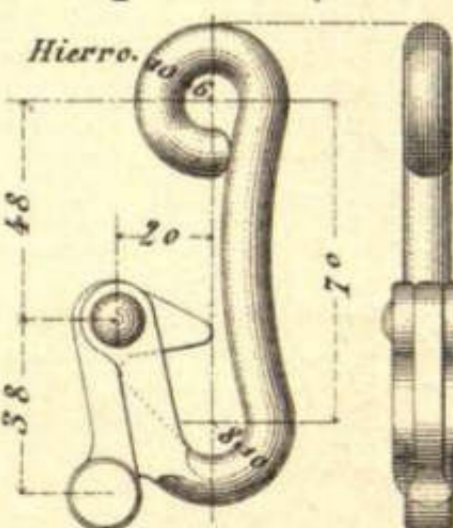

Dado. (4/10)
Bronce.

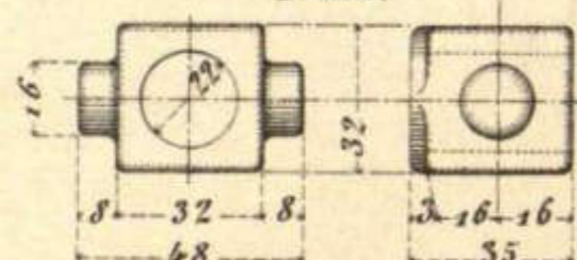

CUREÑA PARA CAÑÓN t.r. DE 75 mm. DE CAMPAÑA SAINT CHAMOND.

RUEDA Y DETALLES.

Escala $\frac{1}{10}$.

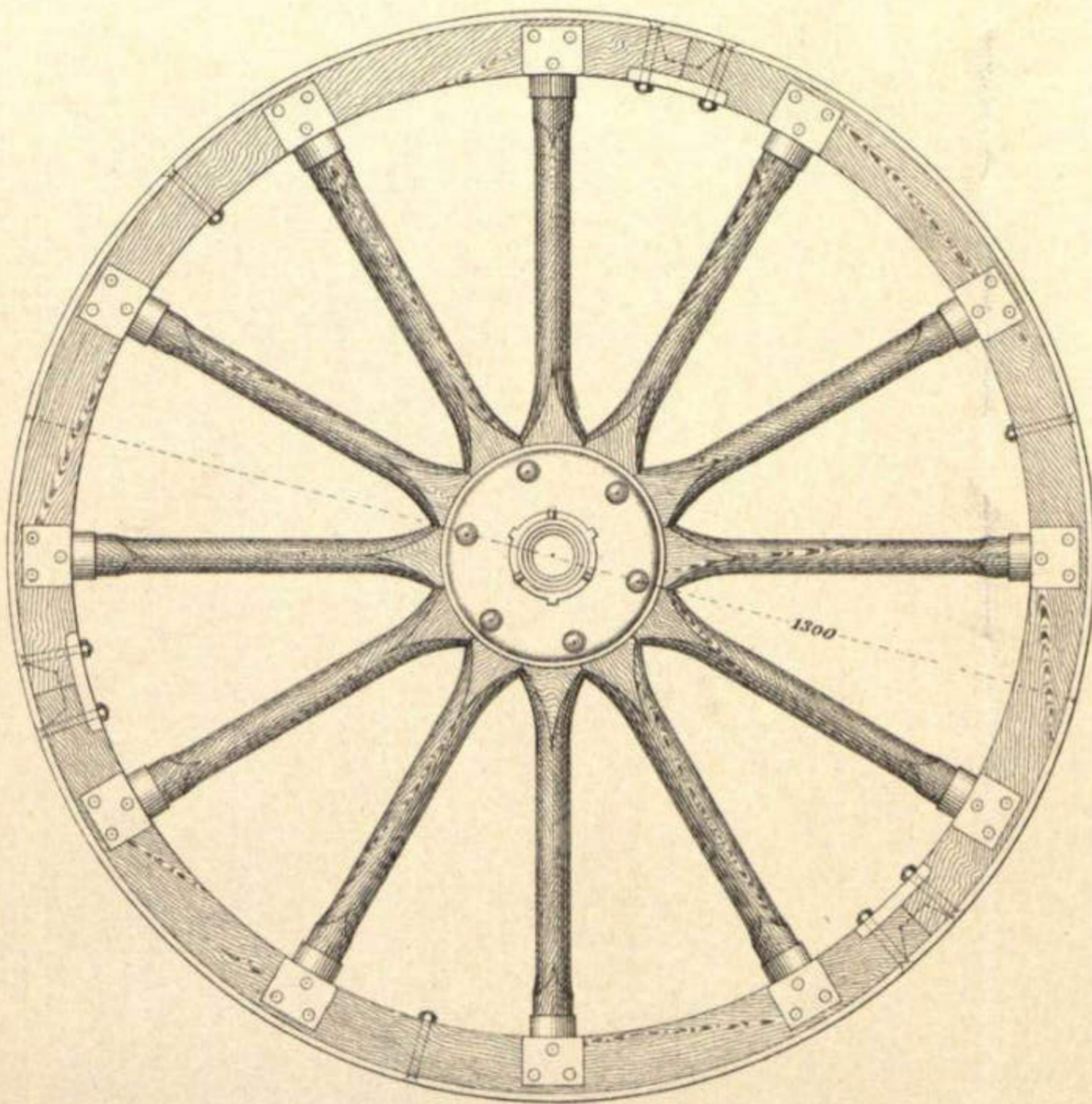

Escala $\frac{2}{10}$.

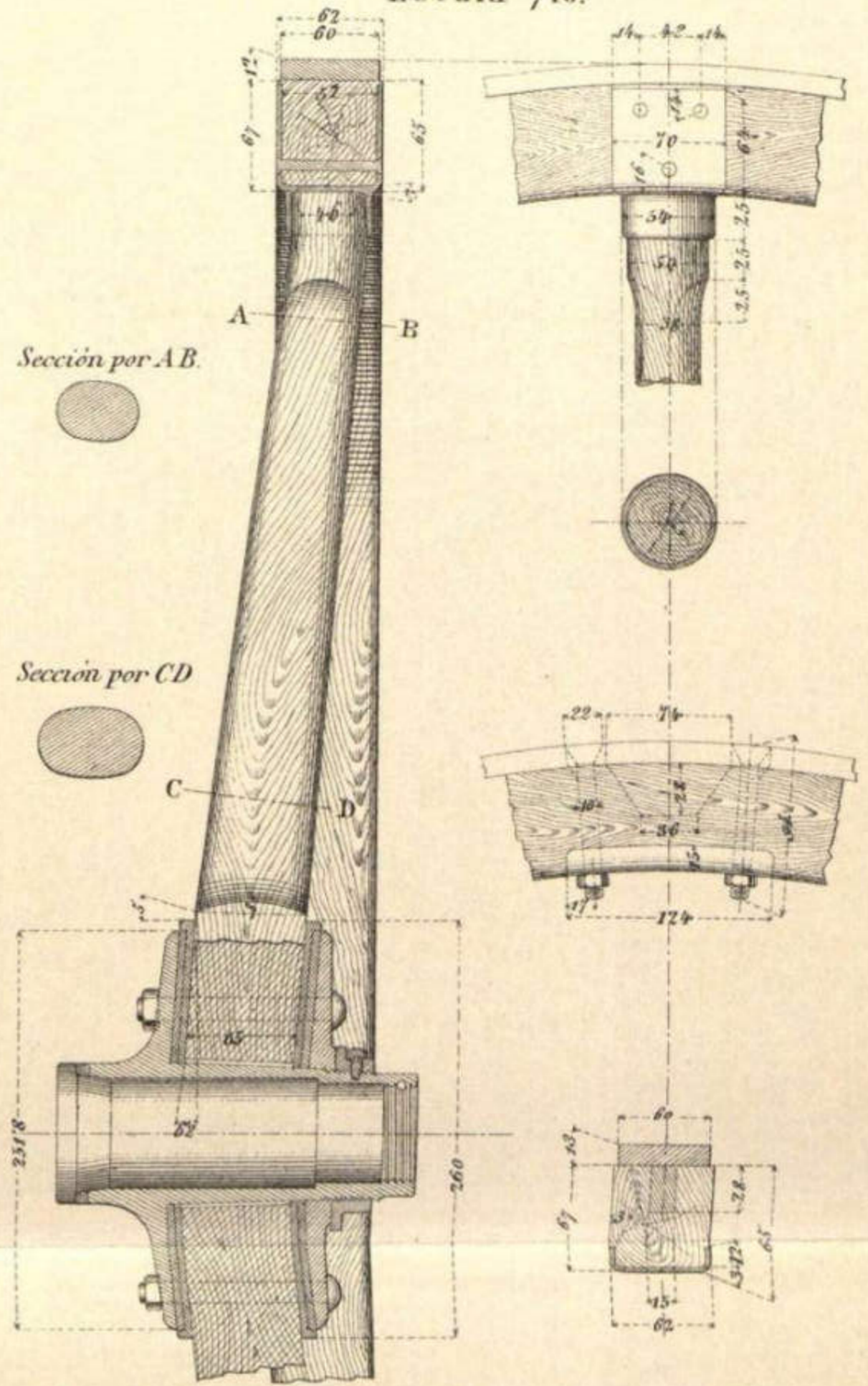

Escala $\frac{3}{10}$.

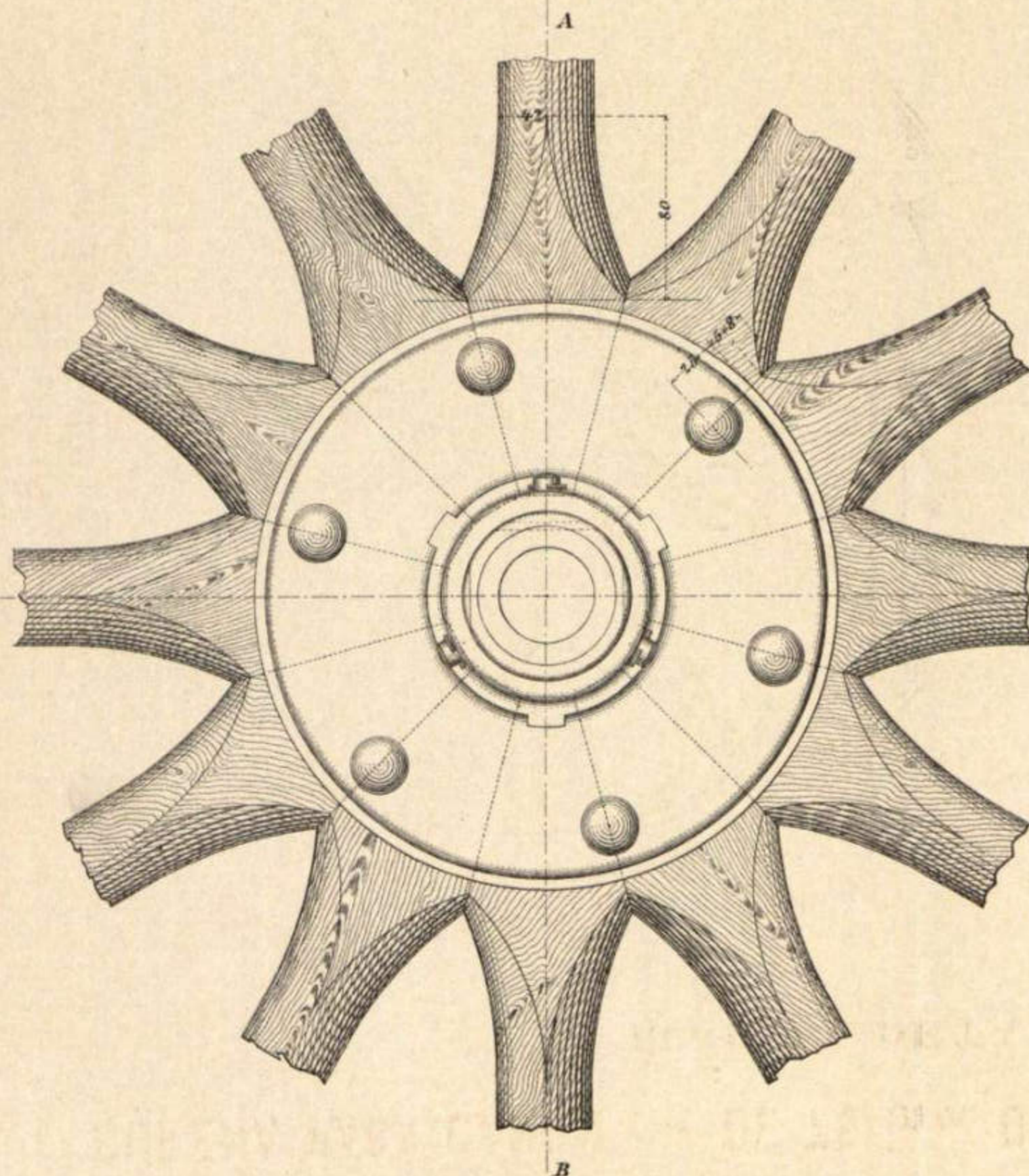

Corte por AB.

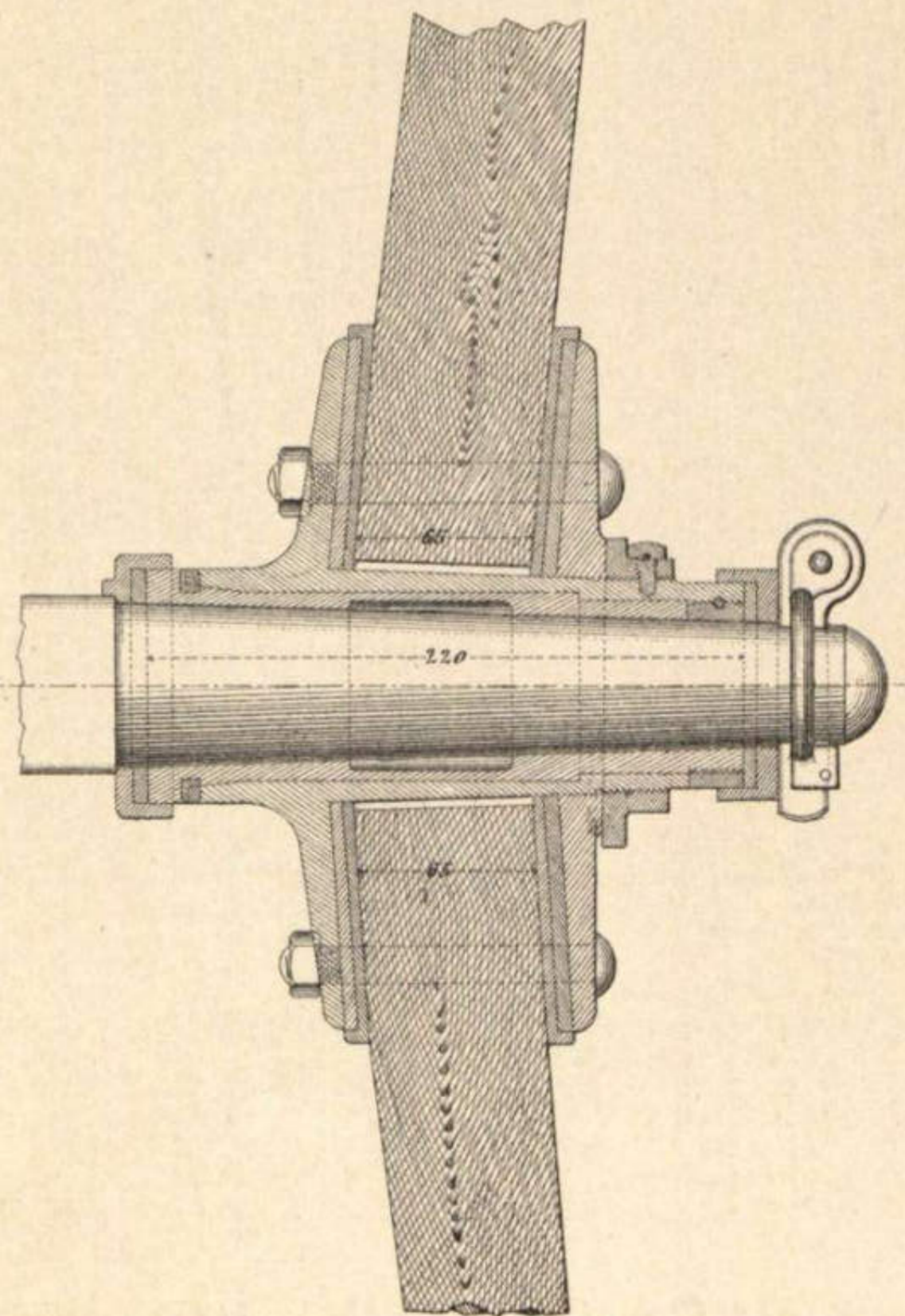

CUREÑA PARA CAÑON t.r. DE 75 mm. DE CAMPAÑA SAINT CHAMOND.

JUEGOS DE ARMAS.

Escobillon-atacador. (E. 5/10.)

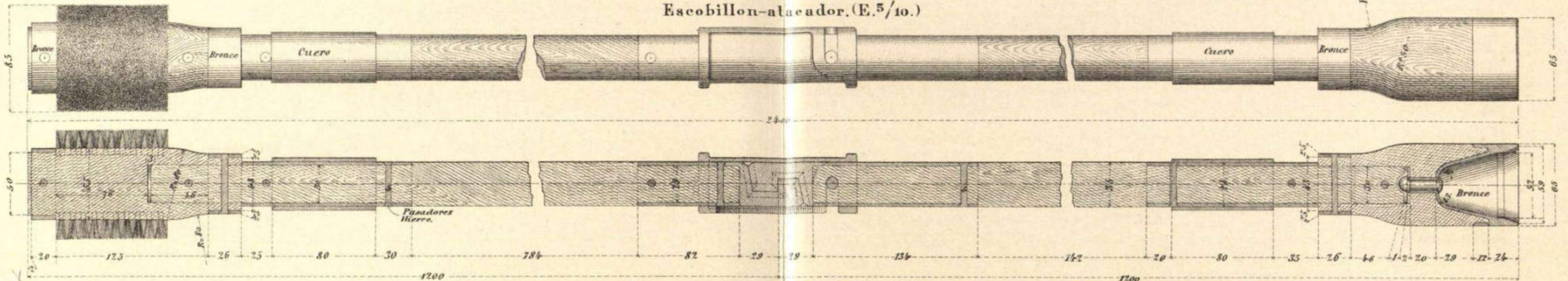

(E. 5/10.)

Piezas metálicas para la union del escobillon atacador. (E. 5/10.)

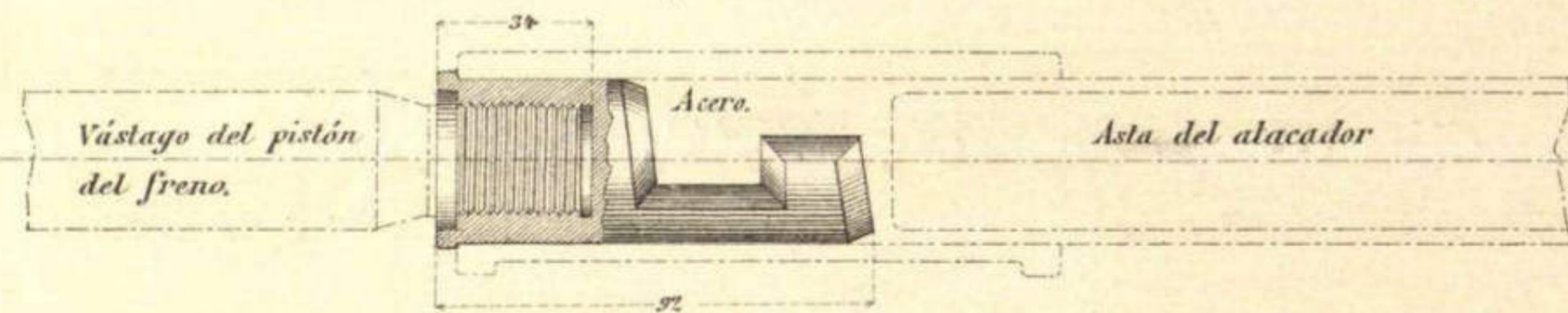

2 Manjuitos. (E. 5/10.)

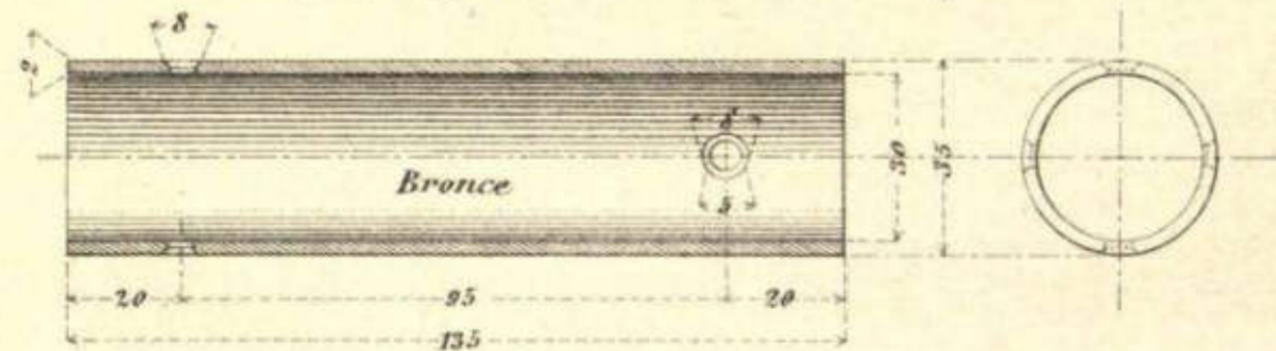

Colgaderos. (E. 4/10)

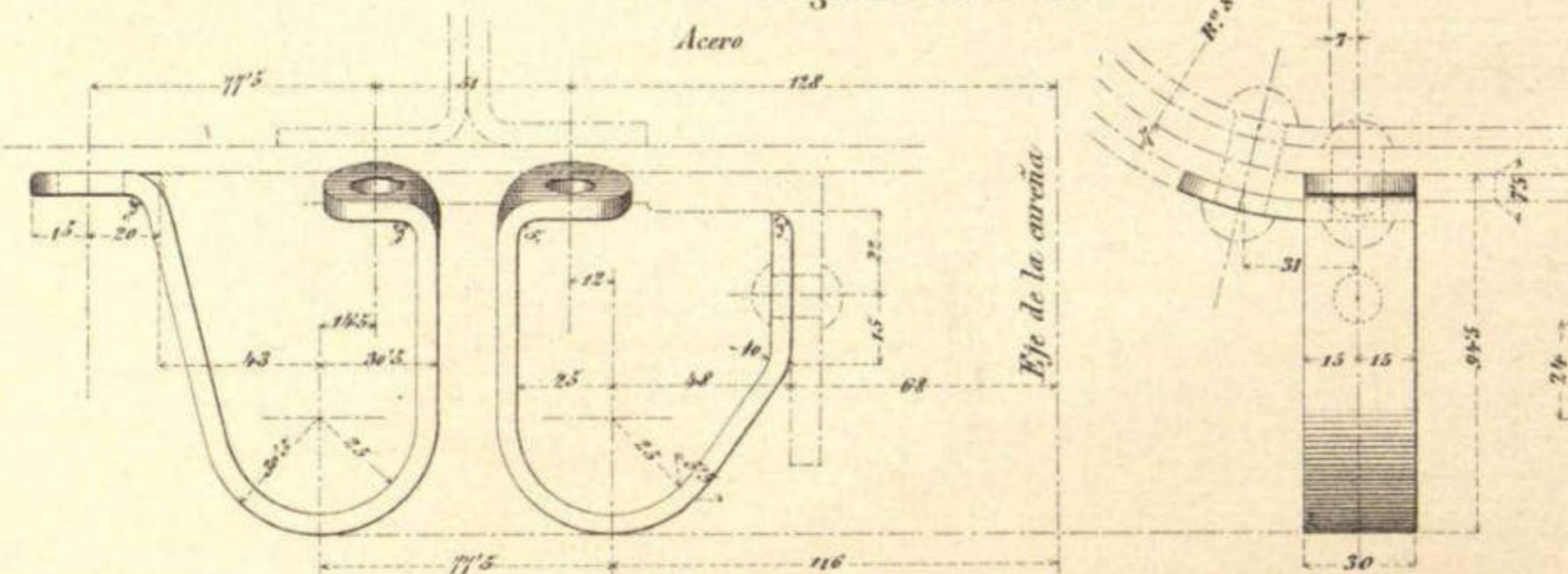

Soporte doble. (E. 4/10)

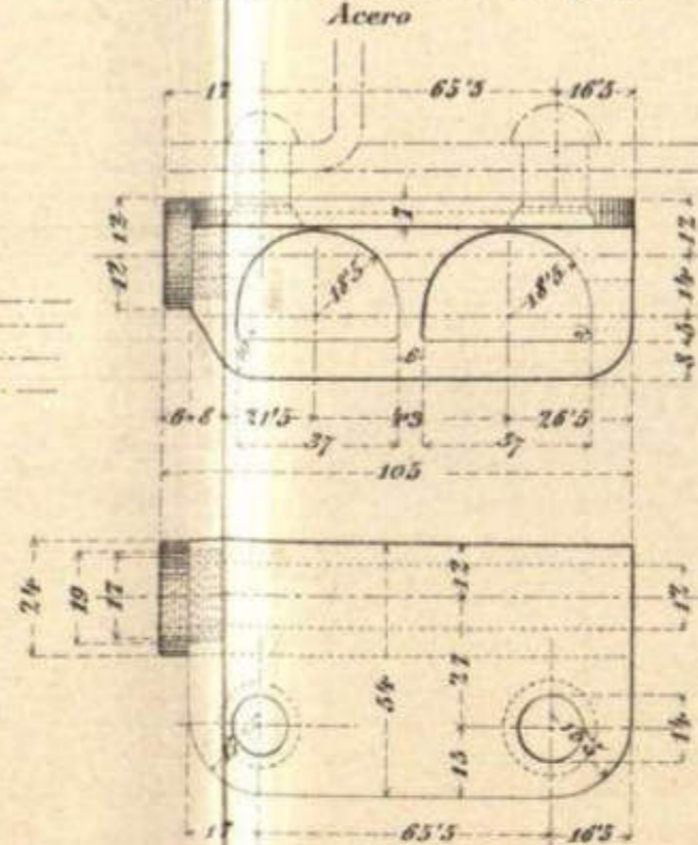

Virola. (E. 5/10.)

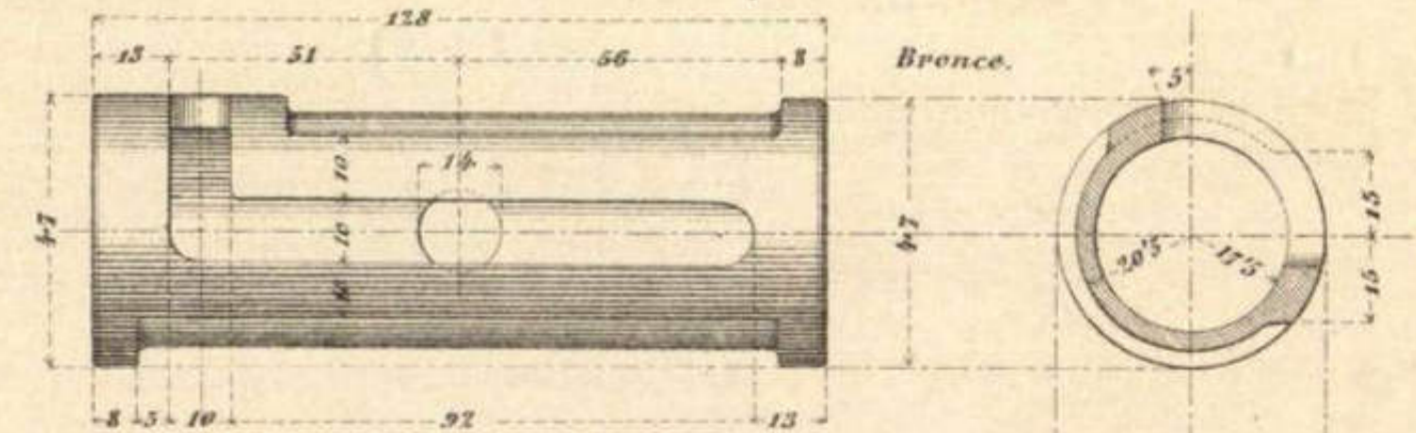

Llave. (E. 4/10)

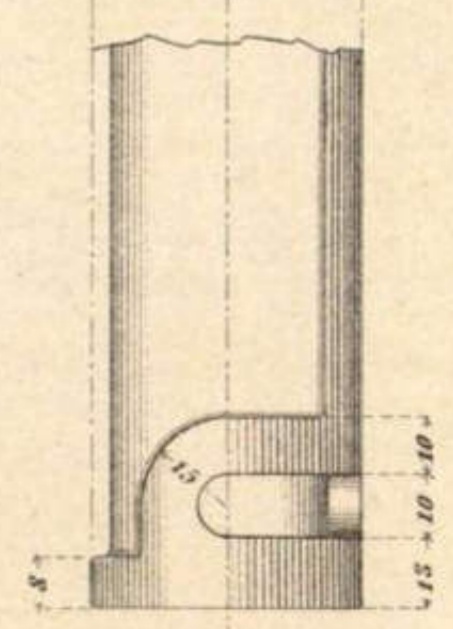
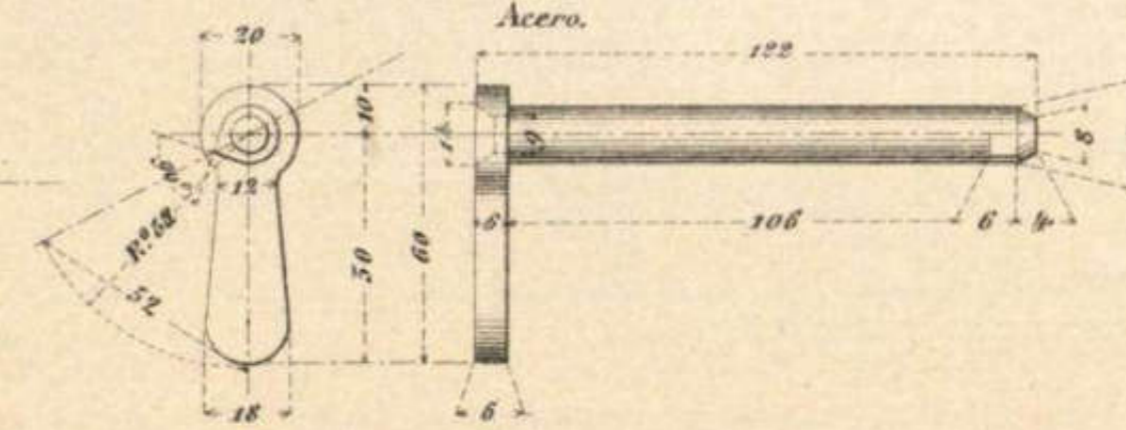

CUREÑA PARA CAÑÓN t. r. DE 75 mm. DE CAMPAÑA SAINT CHAMOND ALZA Y PUNTO DE MIRA.

Escala 5/10.

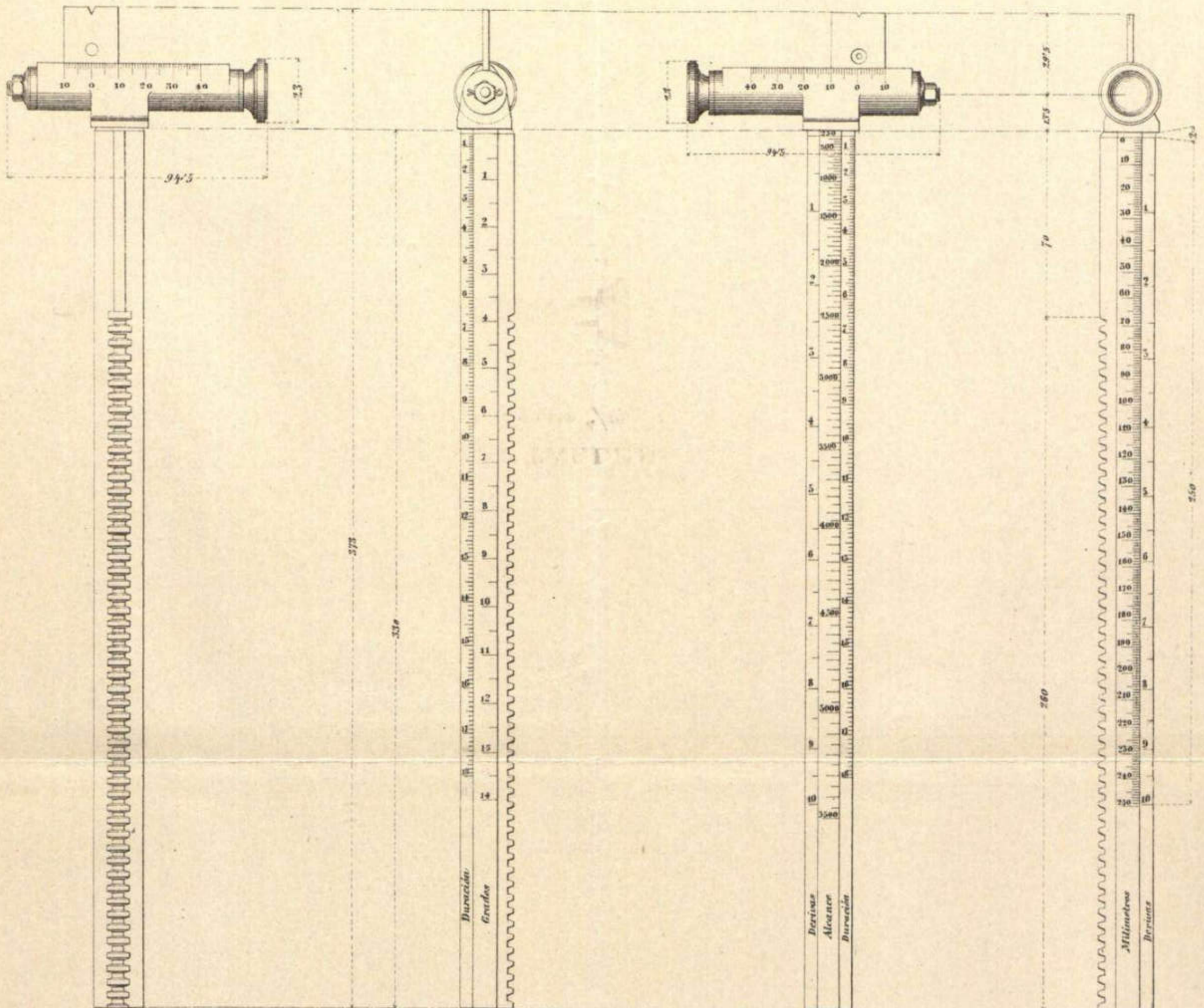

DETALLES Escala 6/10.

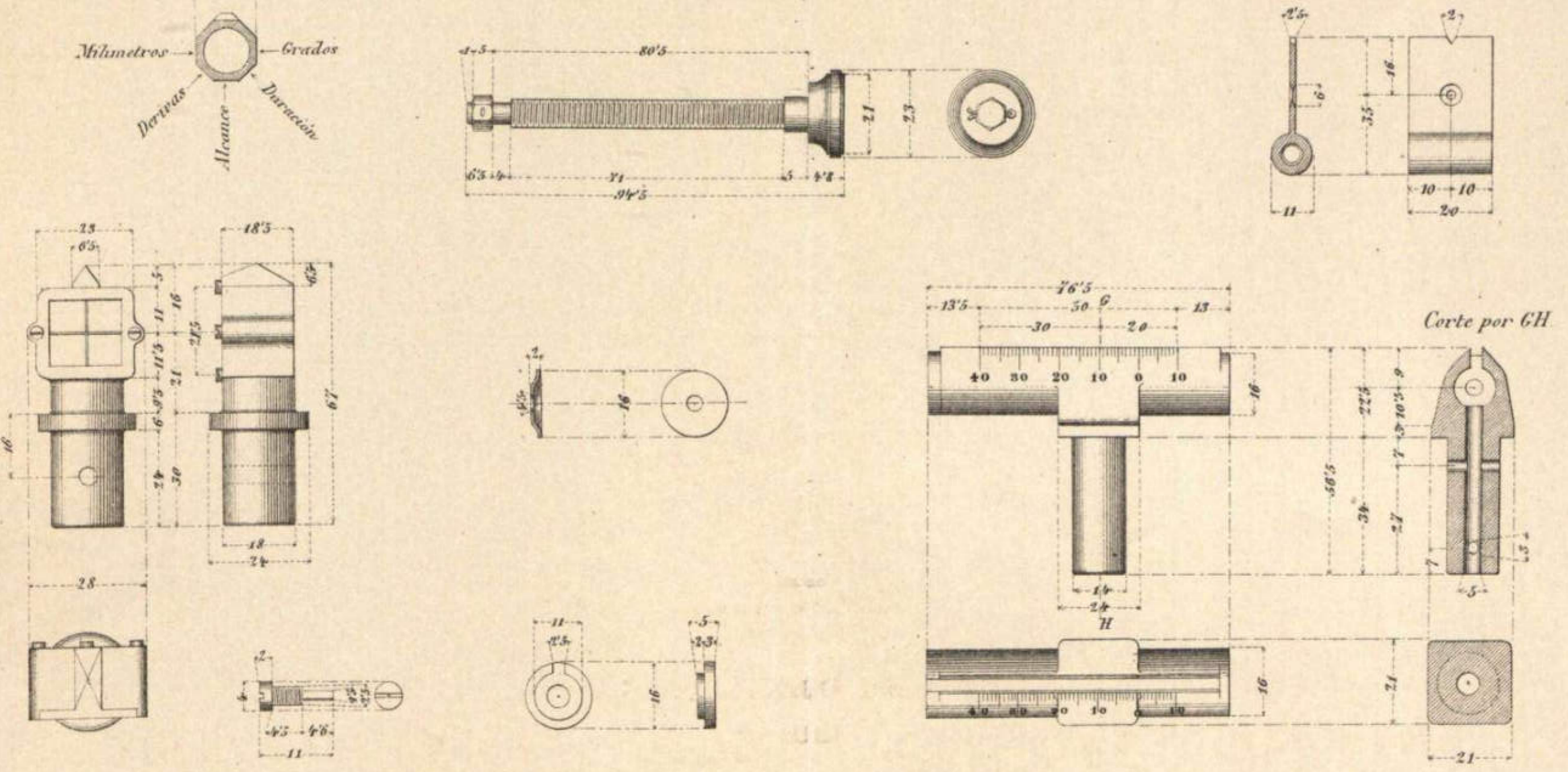

CUREÑA PARA CAÑÓN t. r. DE 75 mm. DE CAMPAÑA KRUPP

VISTA VERTICAL.

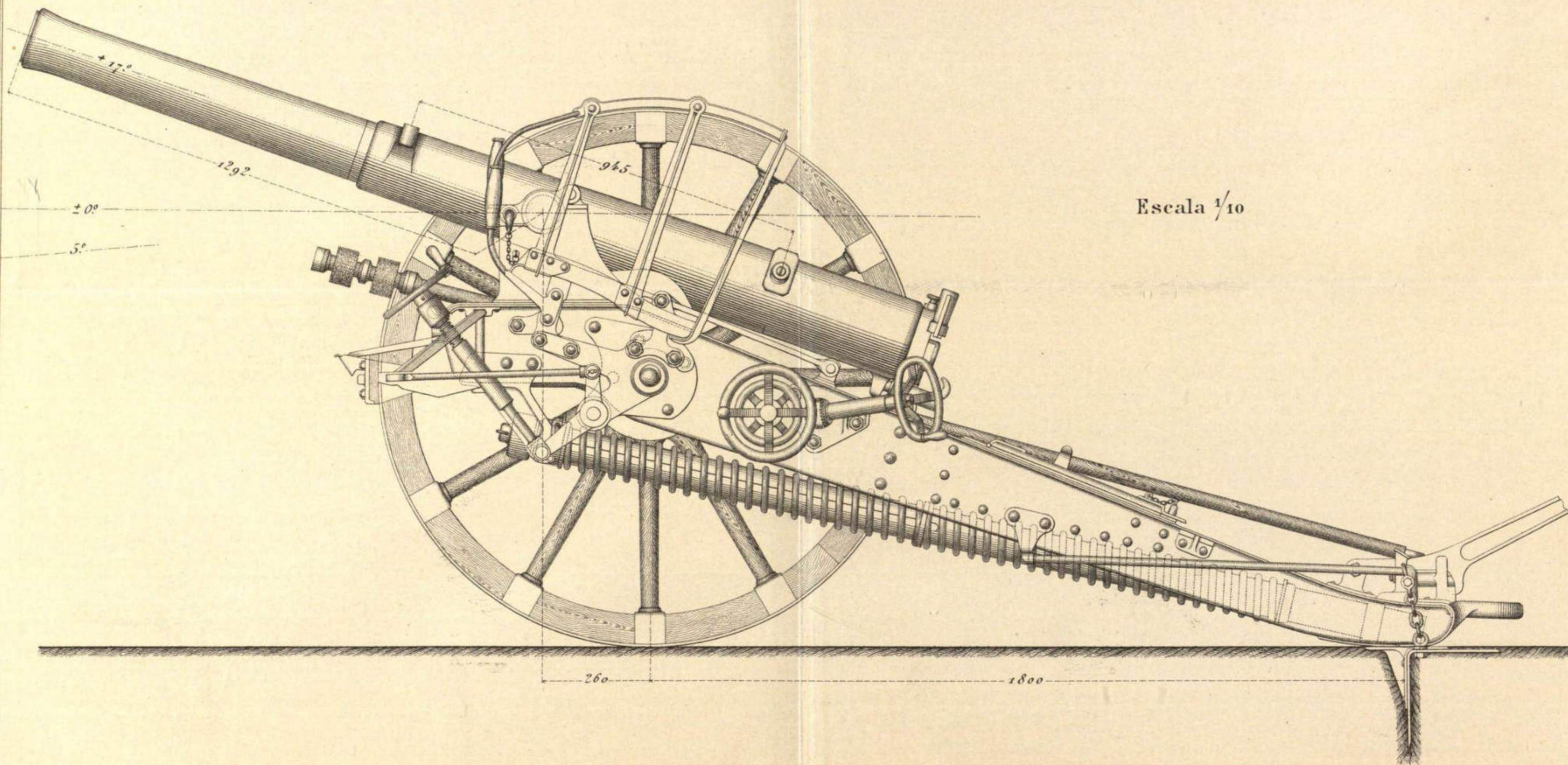

CUREÑA PARA CAÑON t. r. DE 75 mm. DE CAMPAÑA KRUPP

VISTA HORIZONTAL

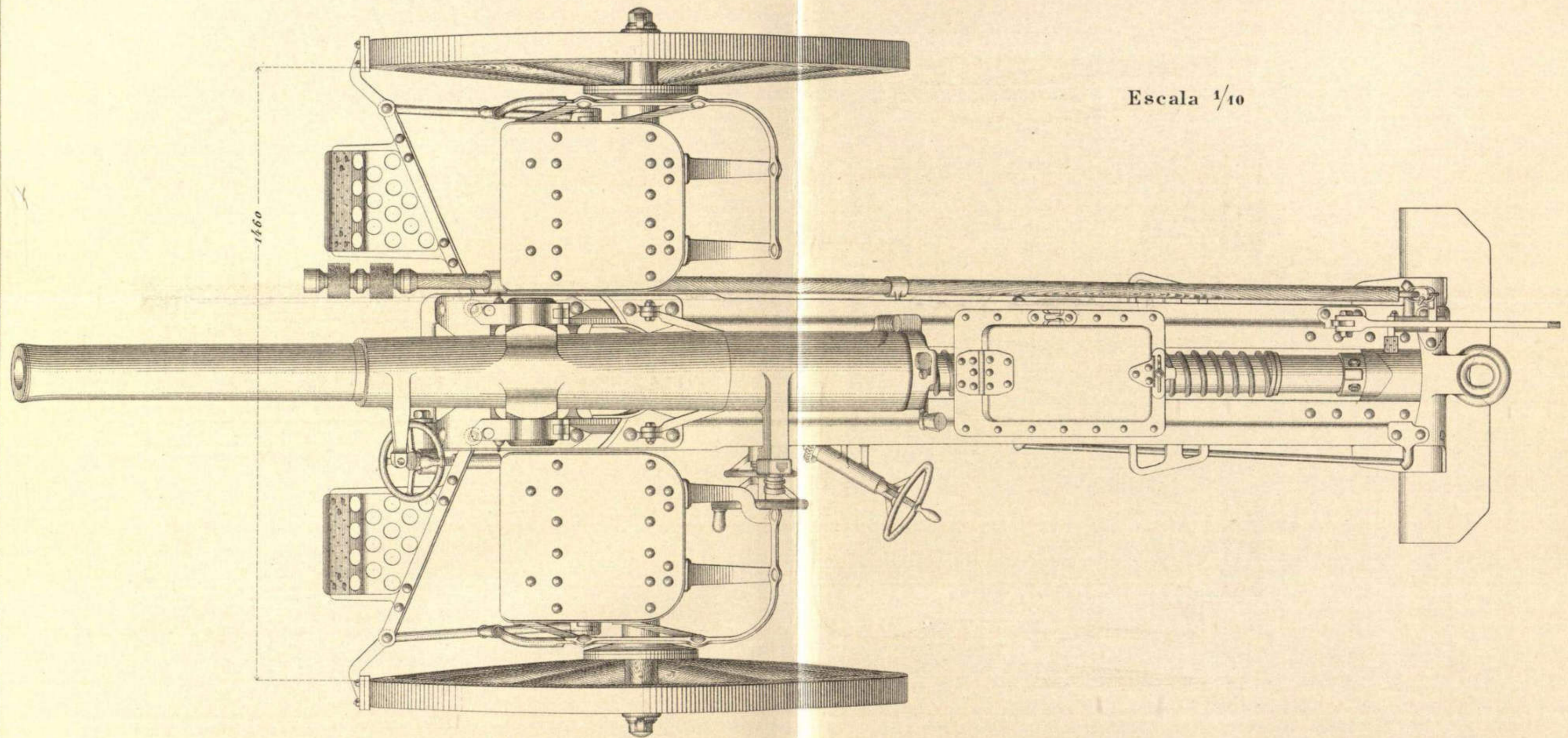

Escala 1/10

CAÑON t. r. DE 75 mm. DE CAMPAÑA KRUPP

DE TALLE S
Escala 8/10.

Escala 1/4.

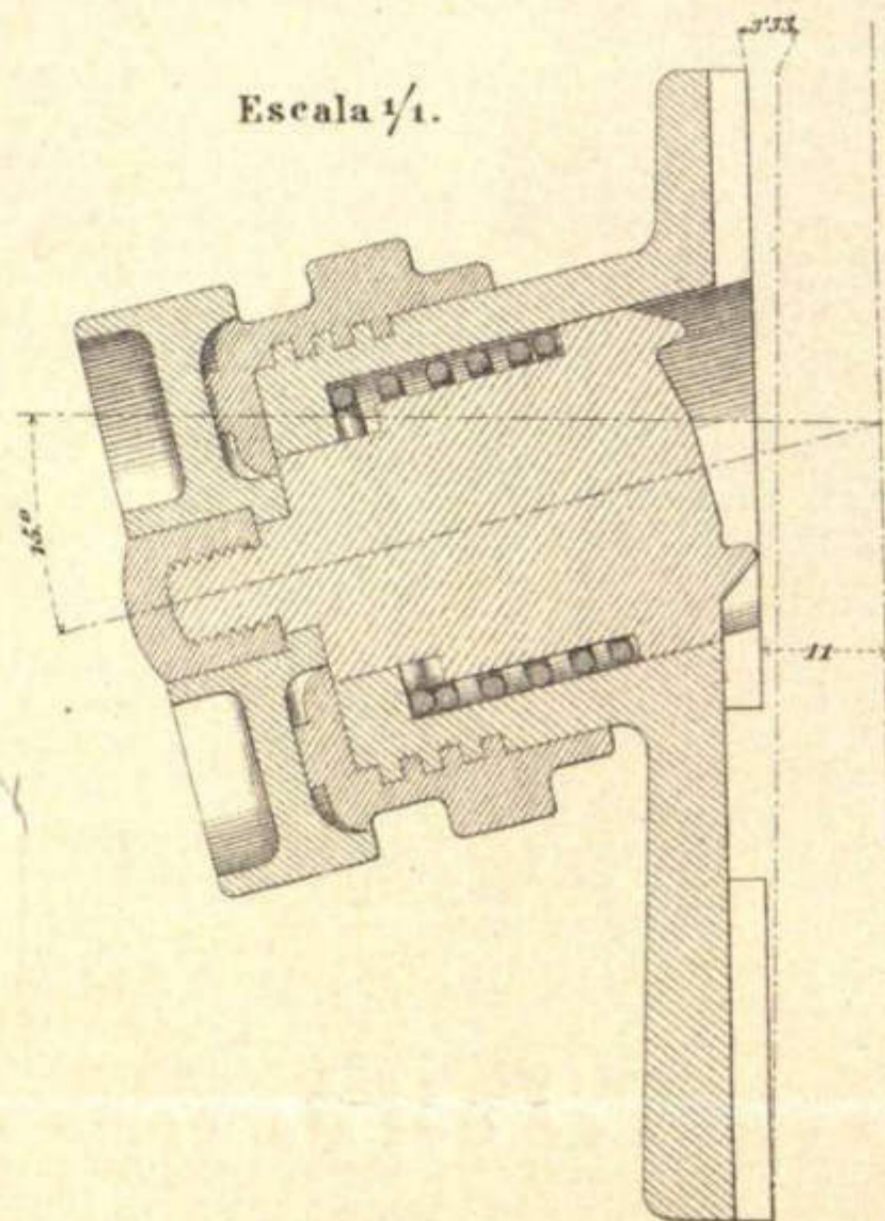

Corona de movimiento.

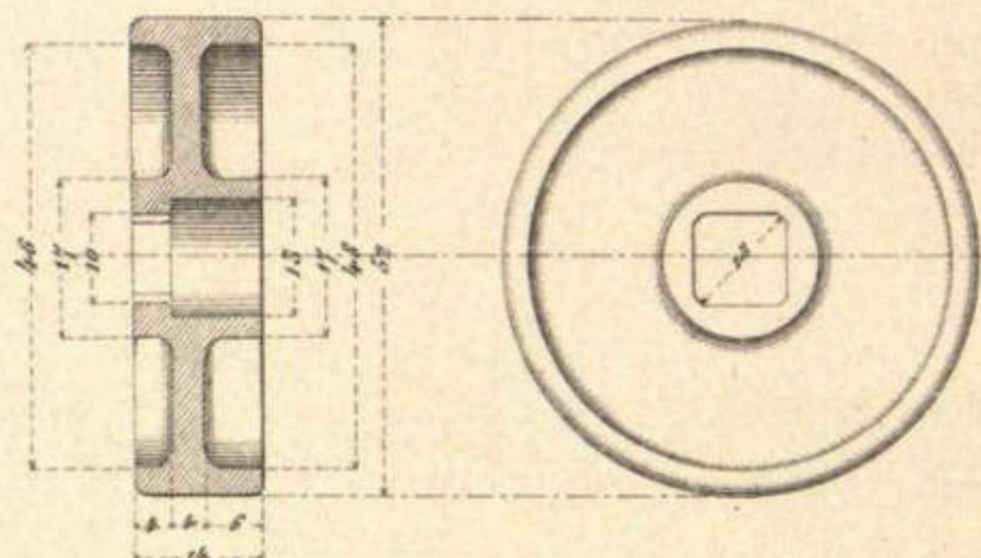

Muelle helicoidal.

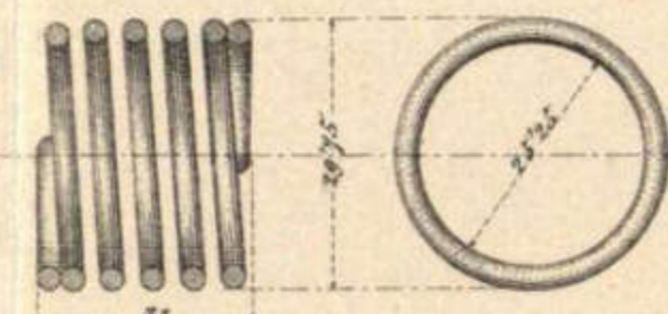

Arbol.

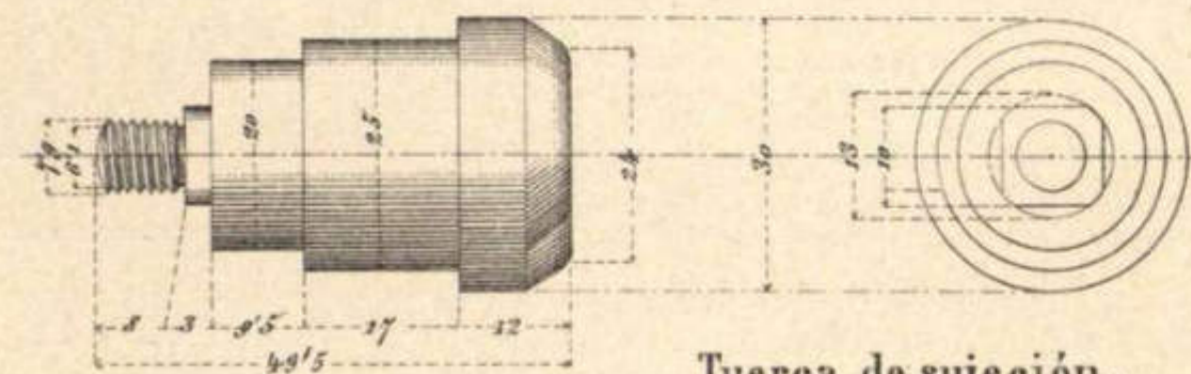

Corona fijadora.

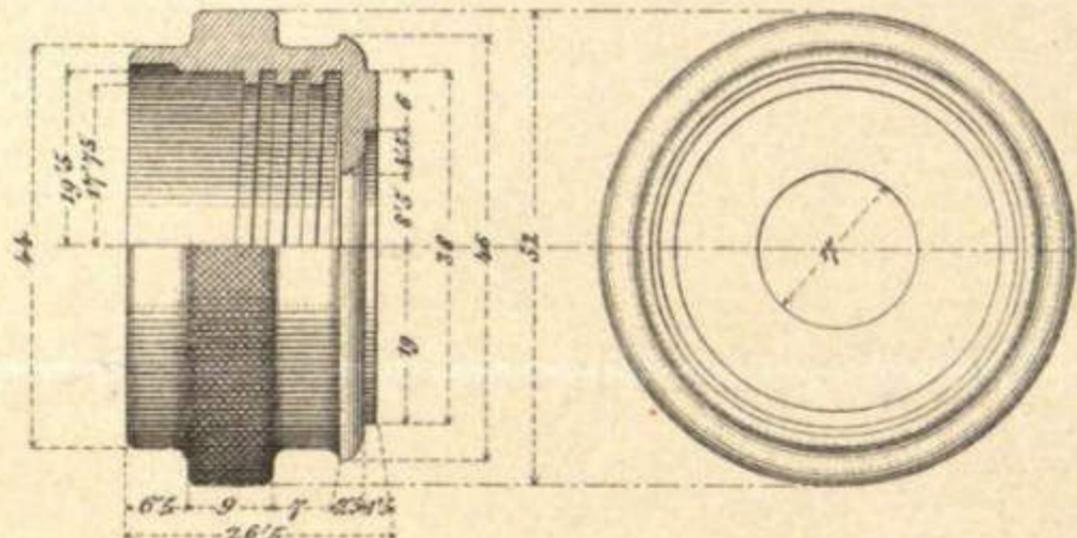

Muelle de lengüeta.

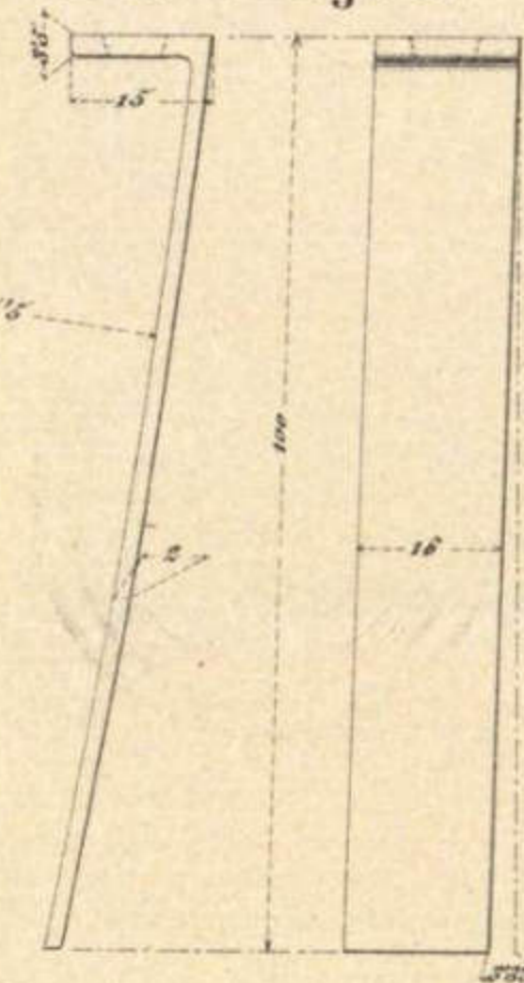

Tornillo del muelle de lengüeta.

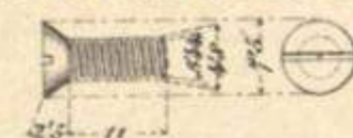

Tuerca de sujeción.

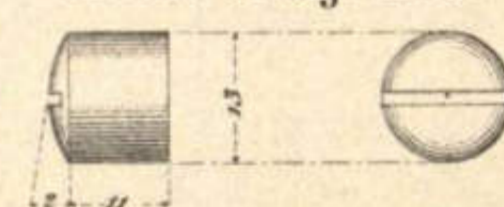

Tornillo del muelle curvo de lengüeta.



Cajera del alza.

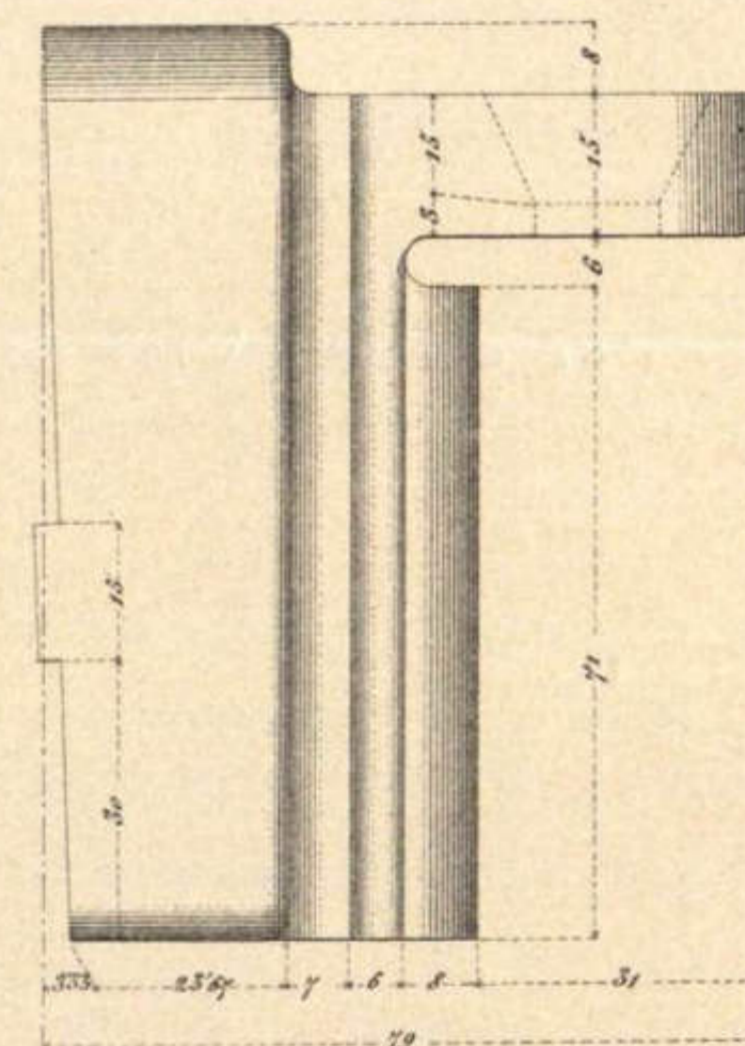

Muelle curvo de lengüeta.

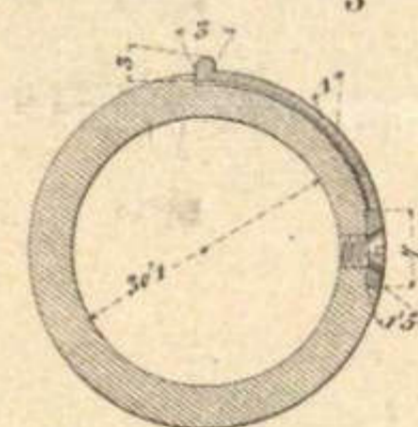

Soporte del punto de mira.

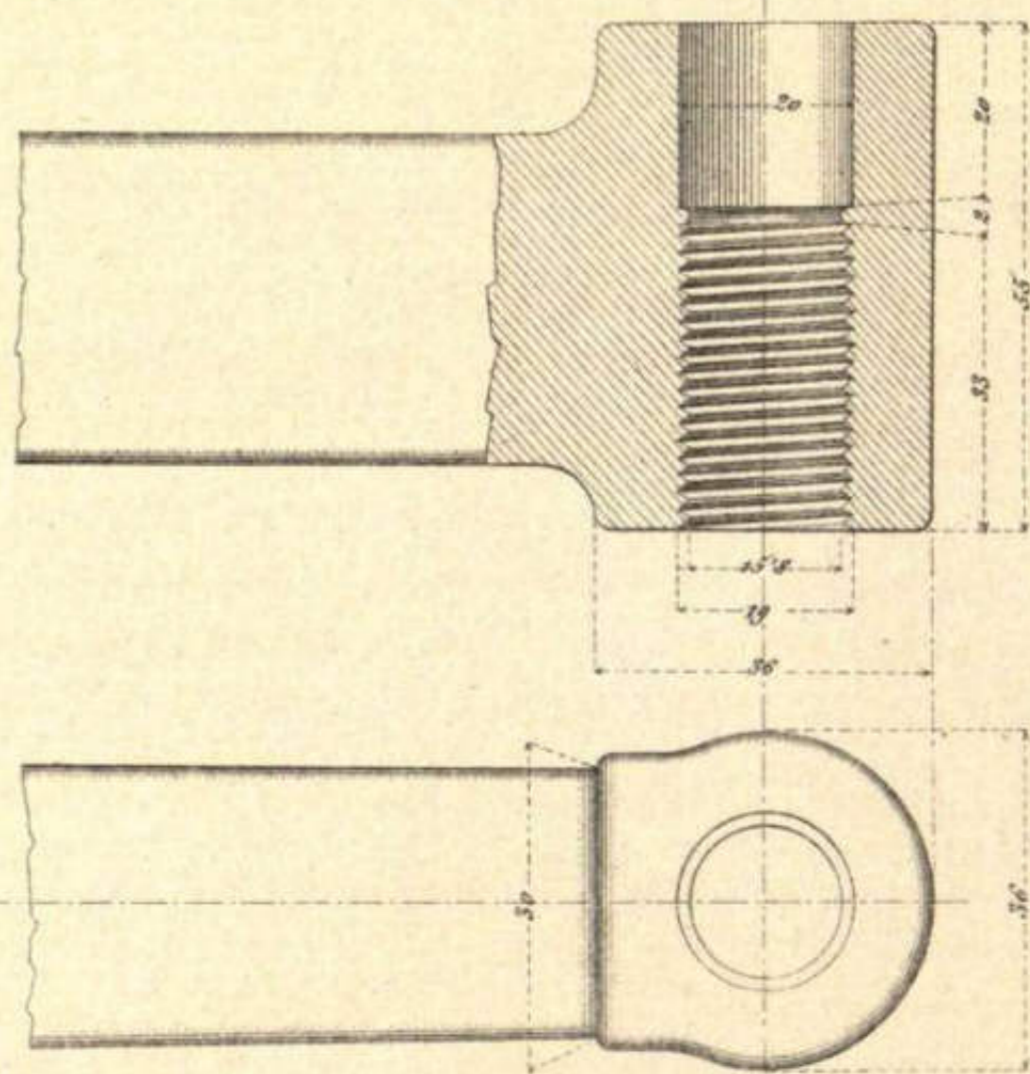

Placa.

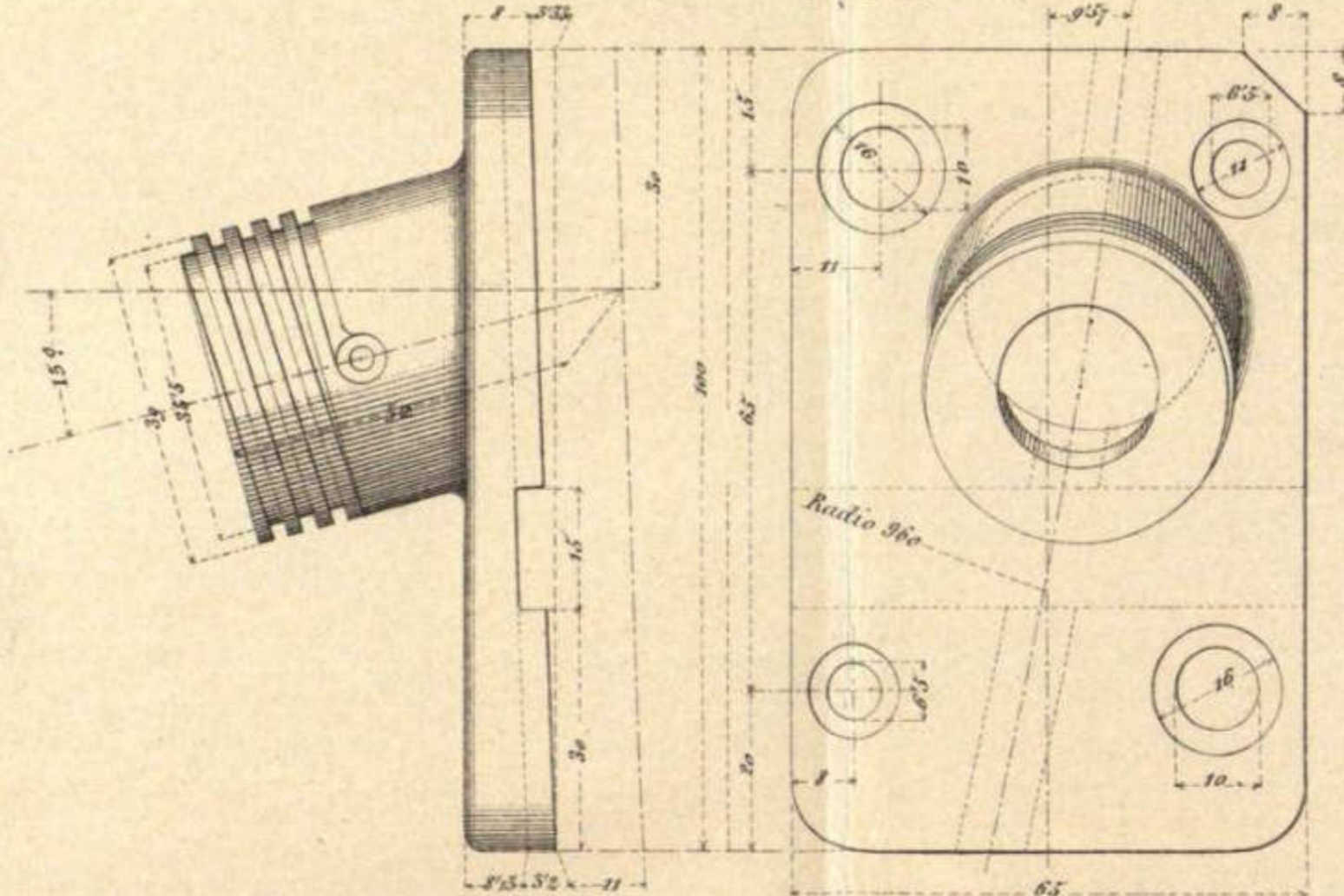

Tornillos de la placa.

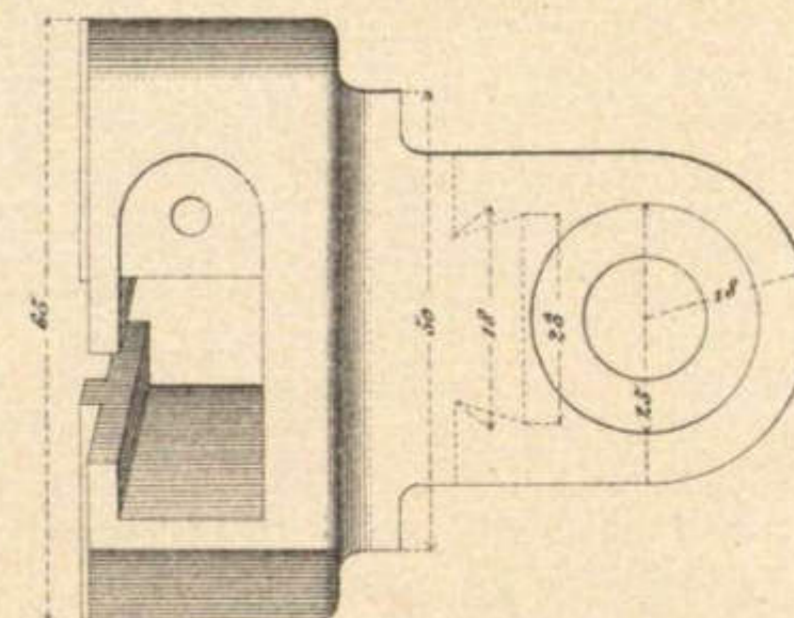
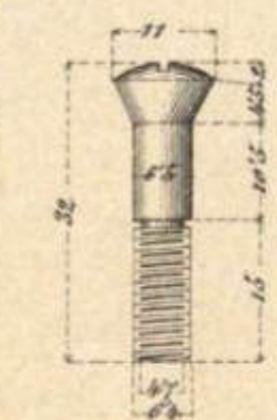
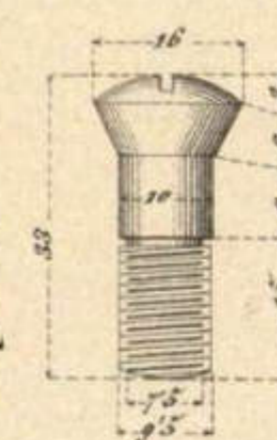

CAÑÓN t. r. DE 75 mm. DE CAMPAÑA KRUPP DE TALLE.

Recámara (E=5/10)

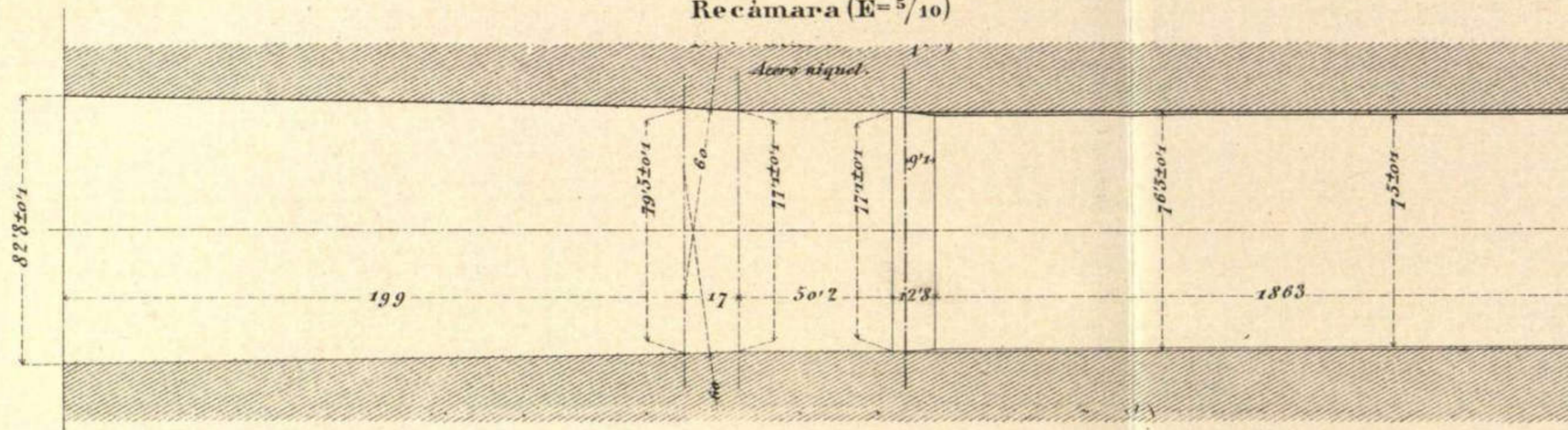

Plano de la boca (E=5/10)

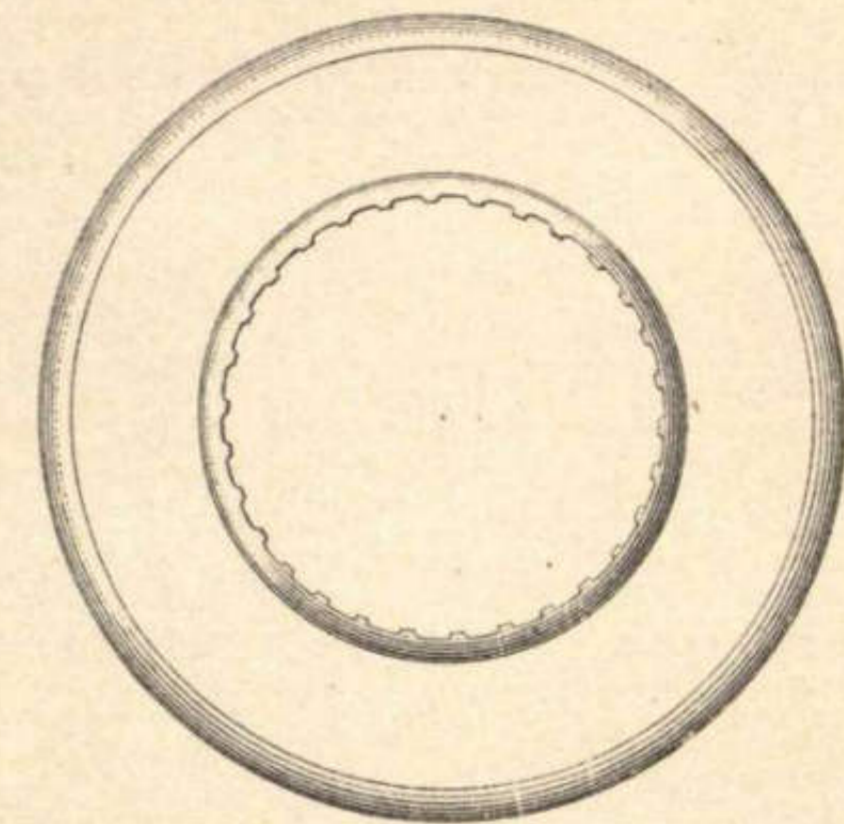

Alojamiento del proyectil en la recámara (E=2/5)

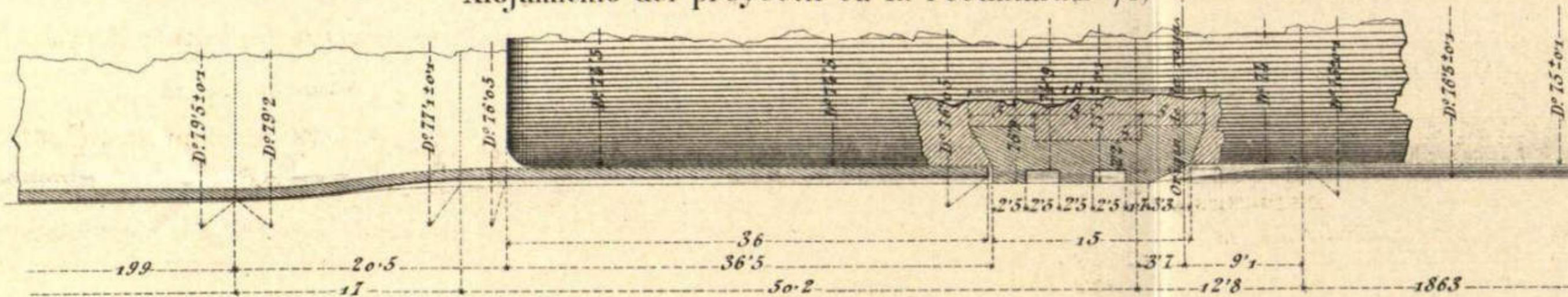

Rayado en la culata (E=5/1)

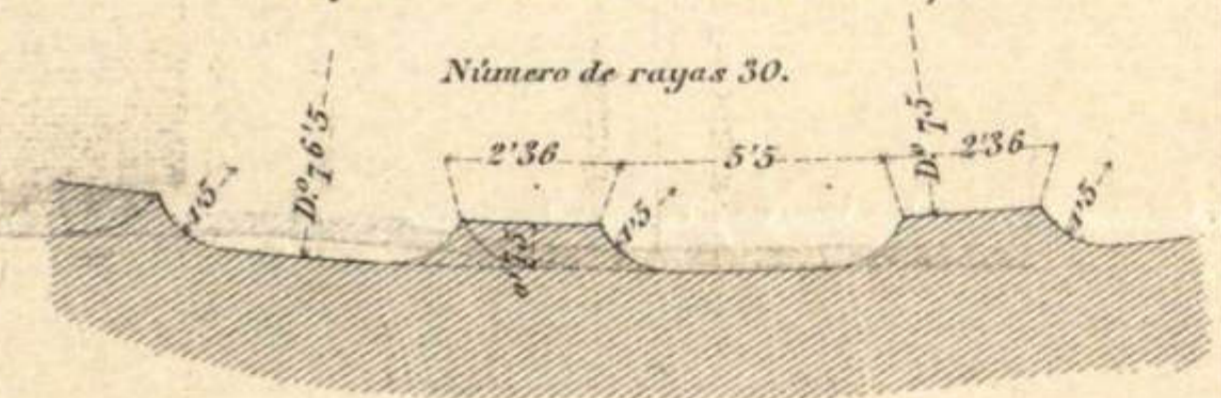

Trazado de una raya, desarrollada sobre un cilindro de 75 m/m. de diámetro. (Paso a la derecha) E=1'5/10.

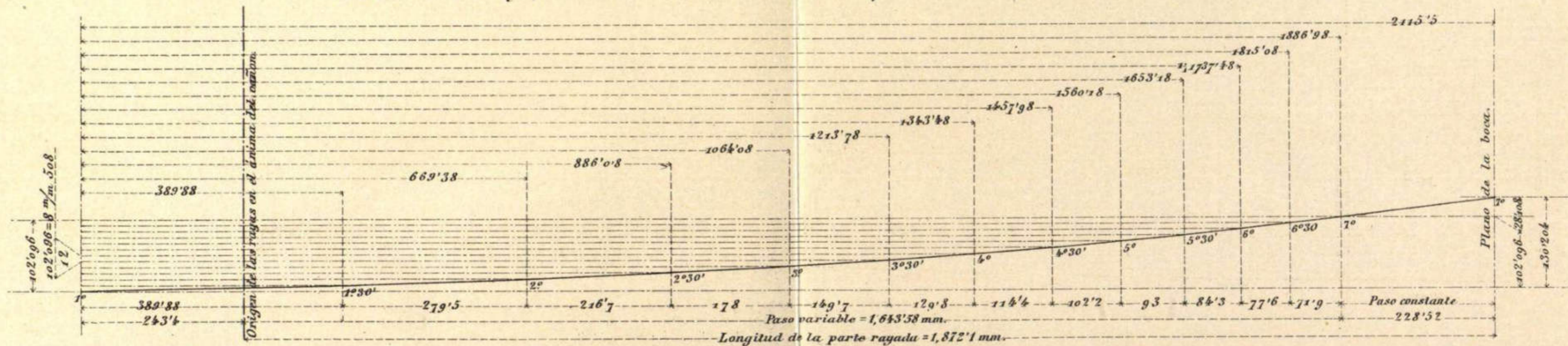

Notas. La raya que lleva el n.º 1 tiene su centro sobre la generatriz superior del plano de la boca, los números de las otras rayas se suceden siguiendo el sentido de la rotación del proyectil.
 El ángulo que hace en cada punto la tangente a la curva con la generatriz del axima, está indicado sobre la ordenada correspondiente a este punto.
 " Entre los puntos determinados por el trazado, la curva puede asimilarse a un arco de círculo. La raya cuyo paso es variable sobre una longitud de 1,643'58 mm. a partir del origen, termina del lado de la boca, en una longitud de 228'52 mm. por una parte de paso constante correspondiente a la inclinación de 1 grados.

CAÑON t. r. DE 75 mm. DE CAMPAÑA KRUPP

VISTAS DEL CIERRE

Escala $\frac{1}{2}$

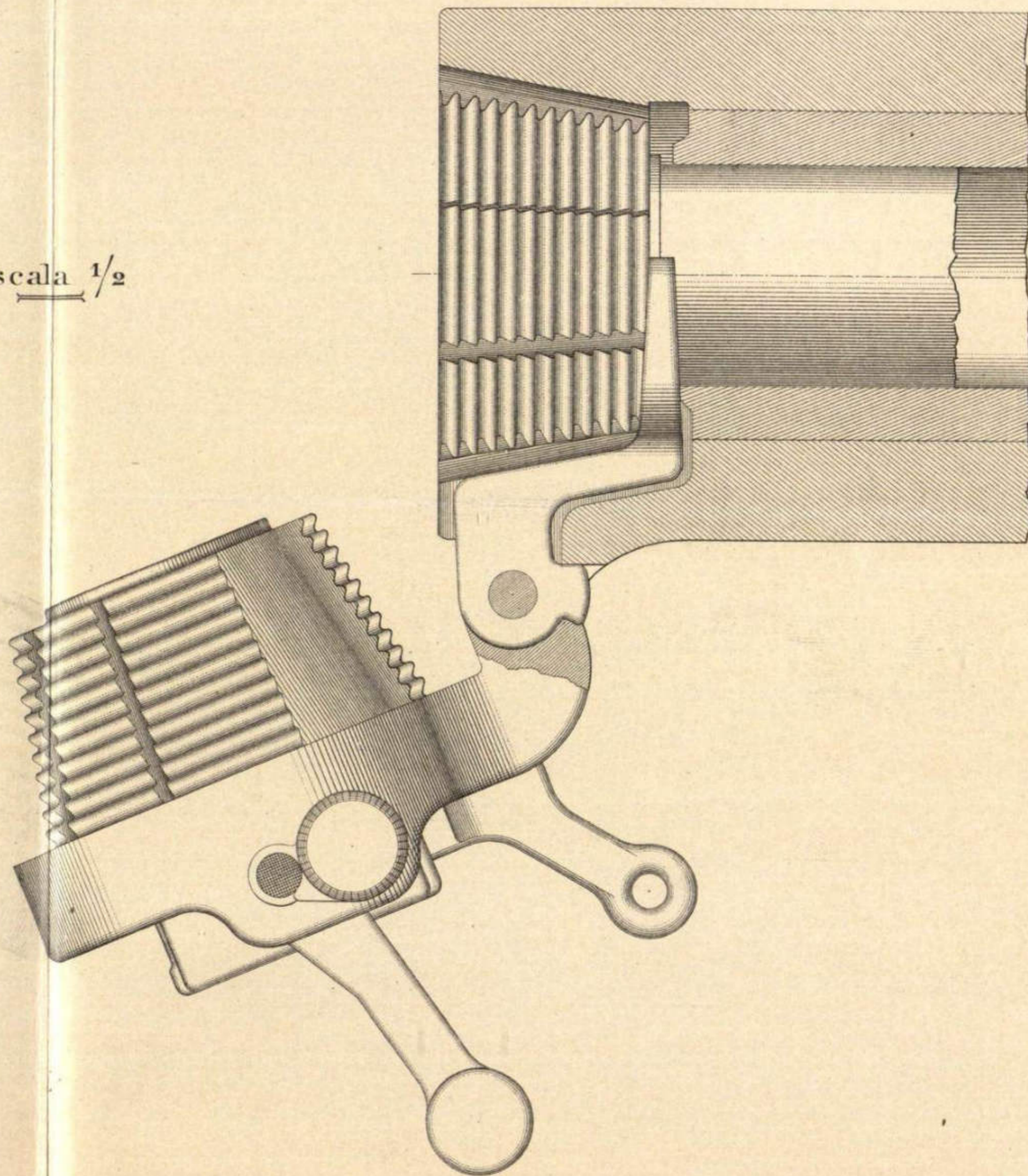
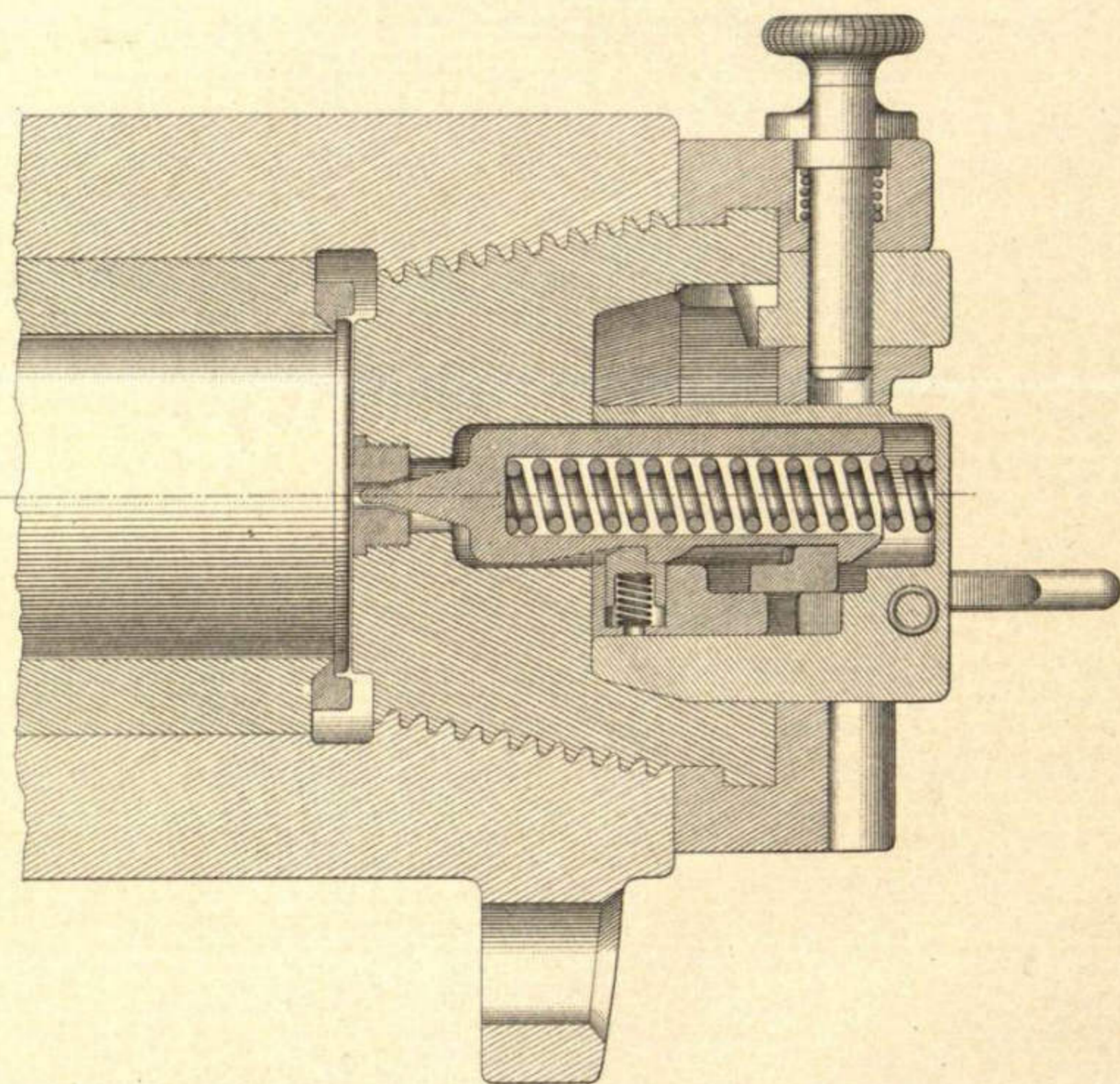

CUREÑA PARA CAÑÓN t. r. DE 75 mm. DE CAMPAÑA KRUPP

APARATO DE PUNTERÍA EN DIRECCIÓN.

Escala 3/10.

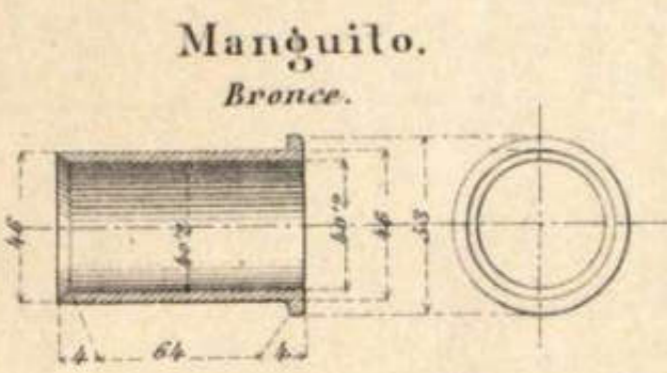
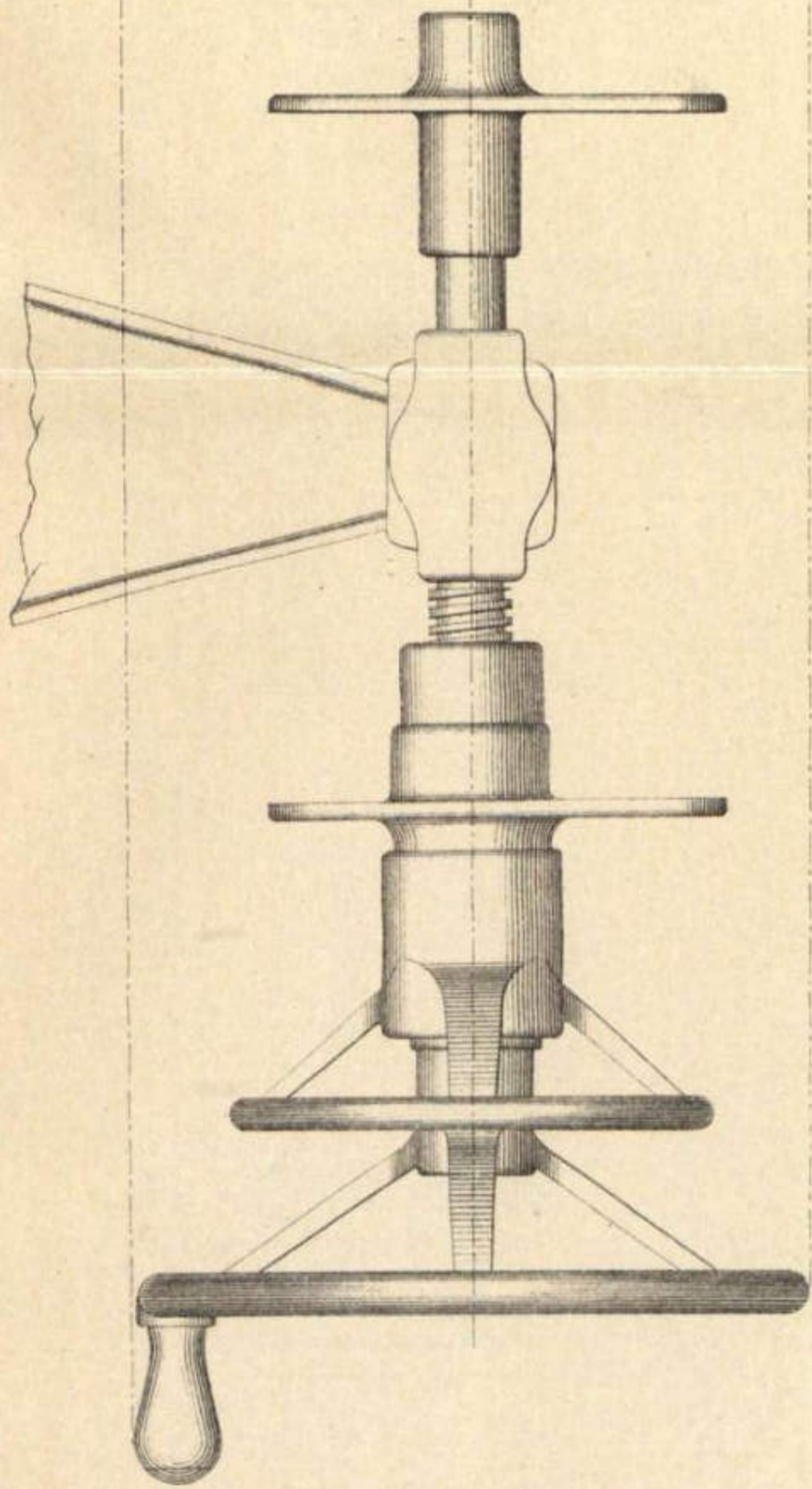
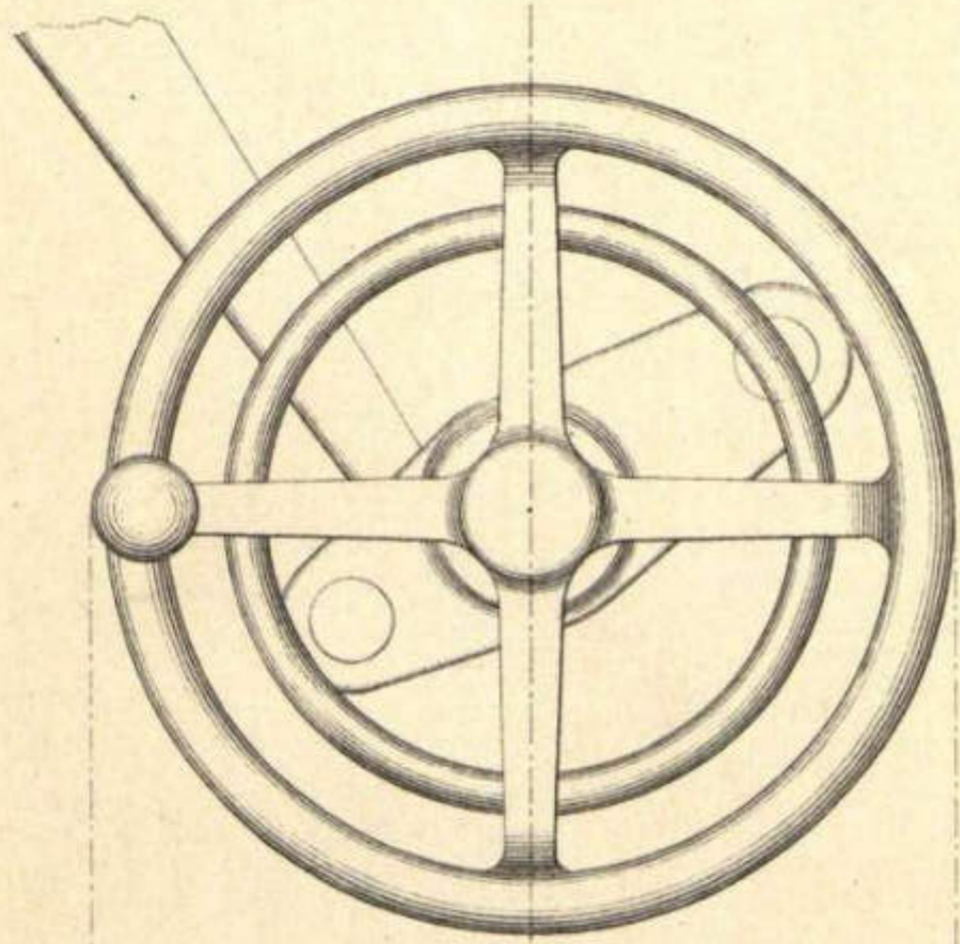

Manquilo.
Bronce.

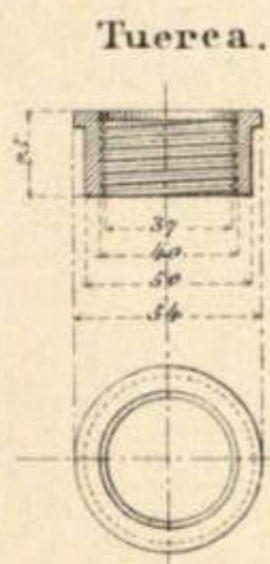

Tuera.

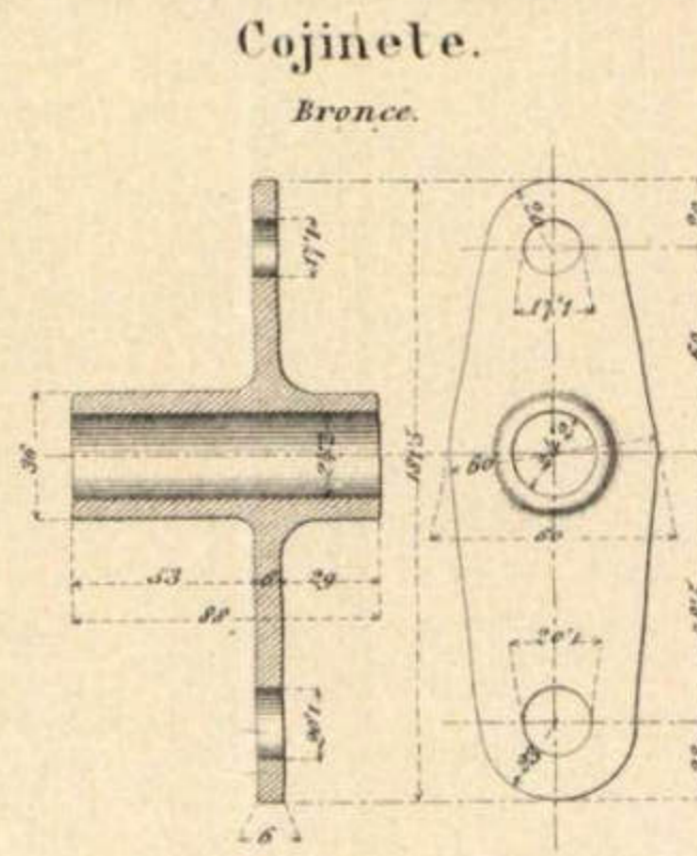

Cojinete.
Bronce.

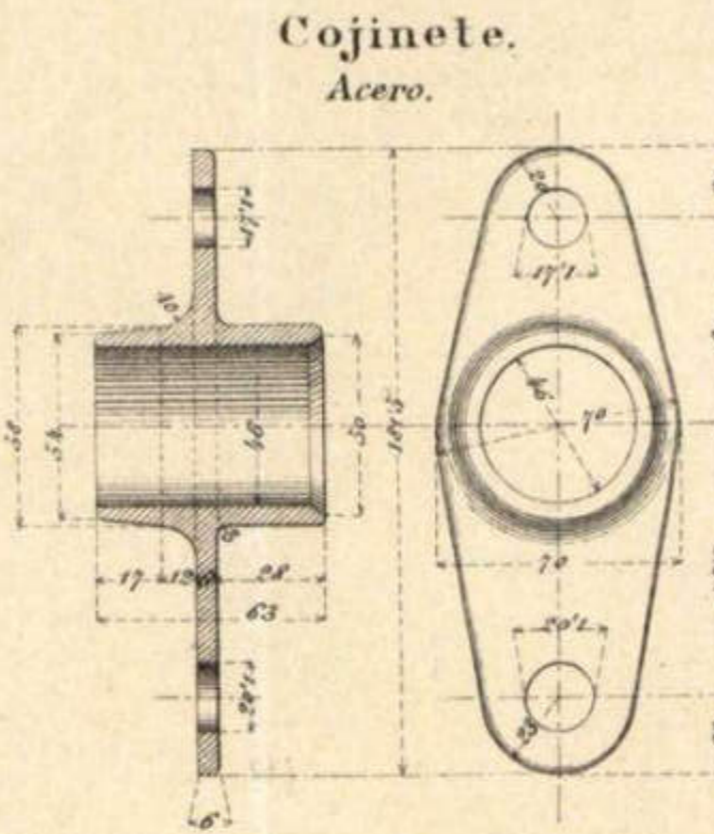

Cojinete.
Acero.

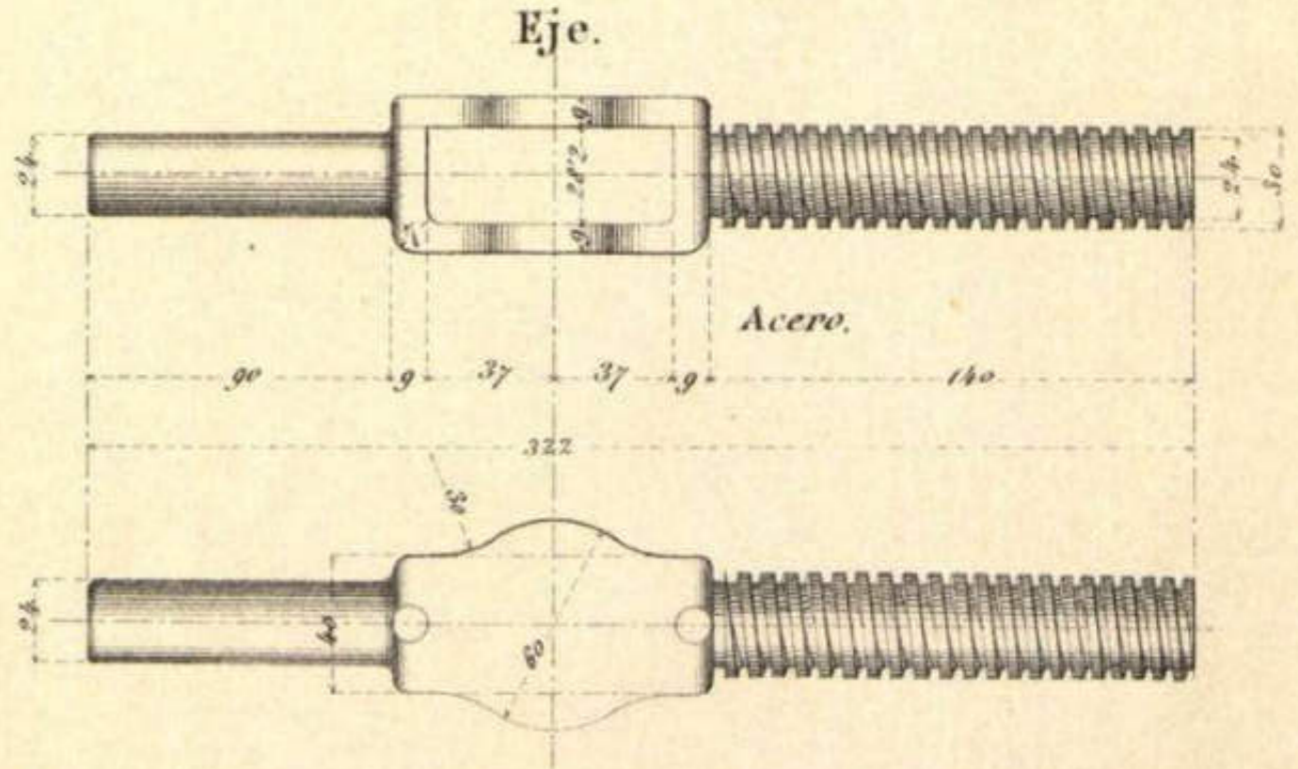

Eje.

Acero.

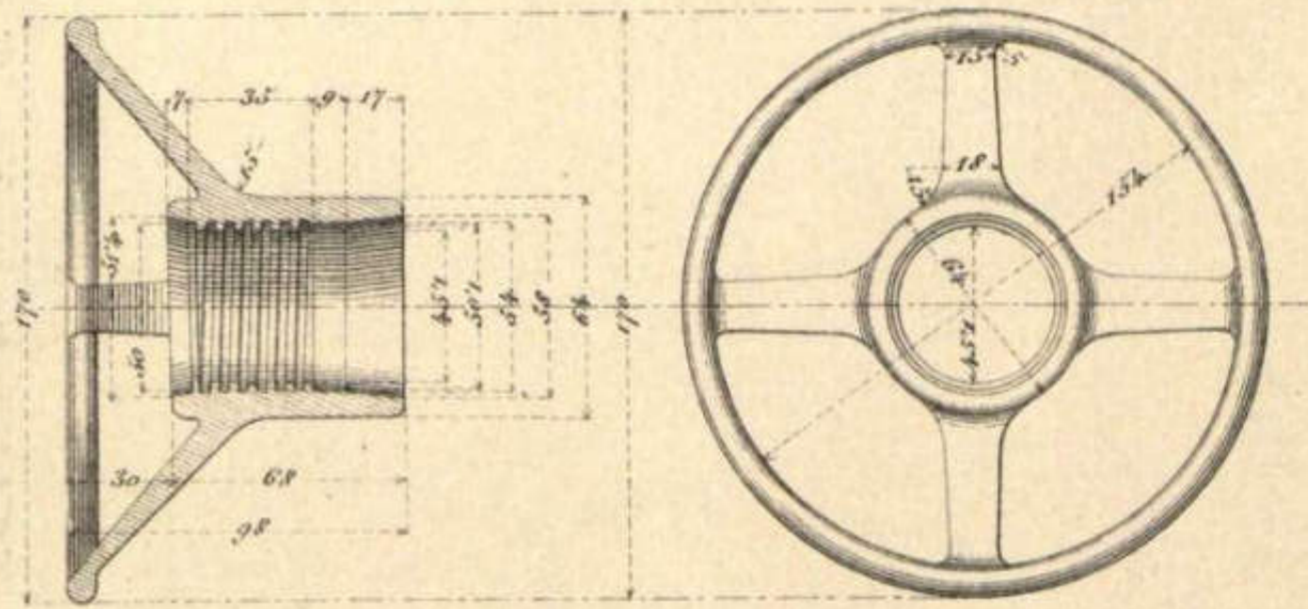

Volante freno.
Acero.

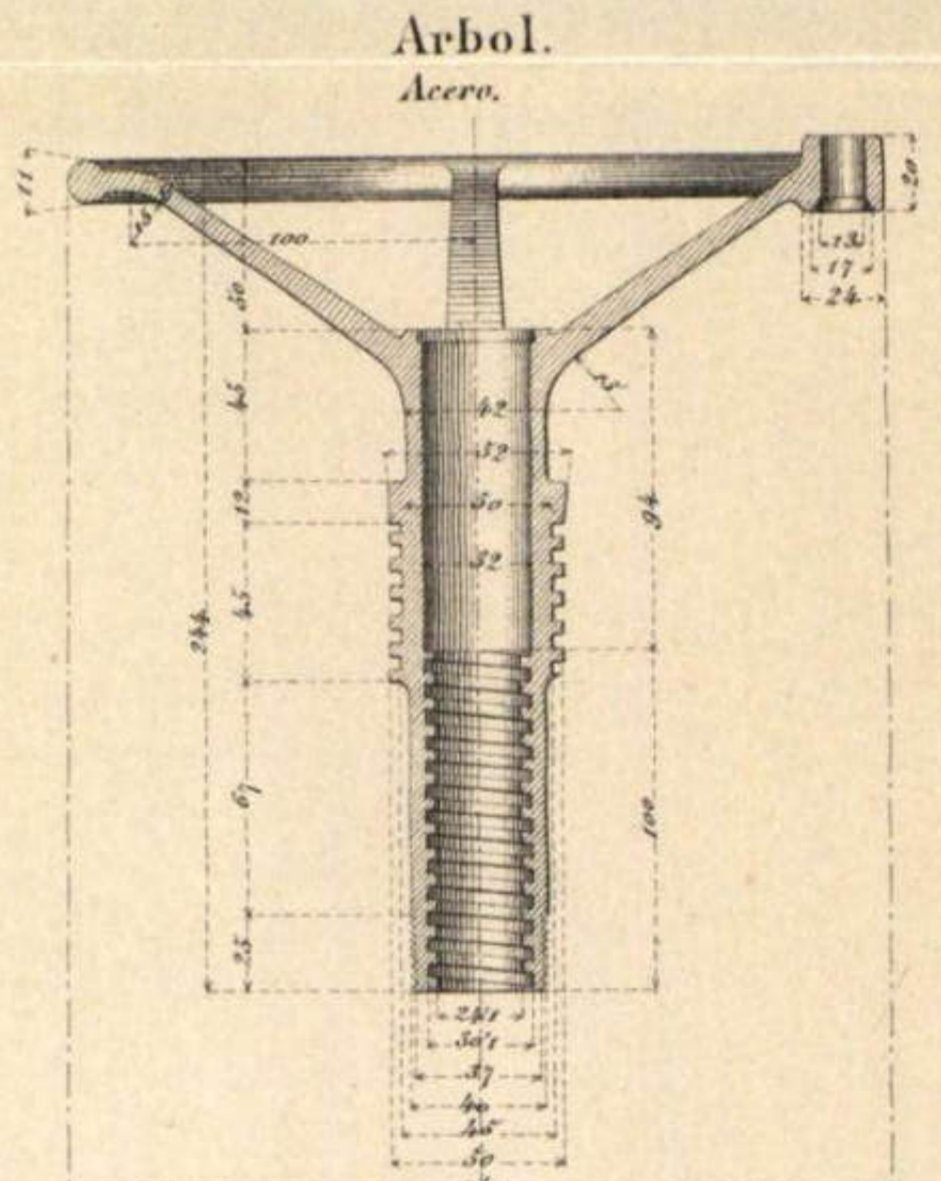

Arbol.
Acero.

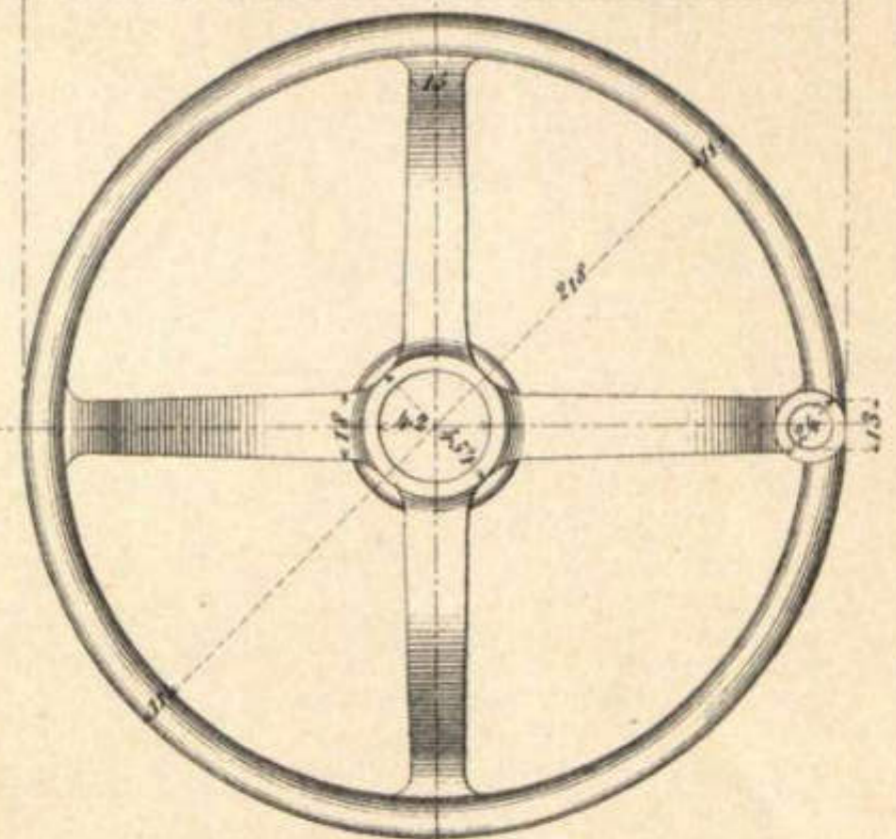

CUREÑA PARA CAÑÓN t. r. DE 75 mm. DE CAMPAÑA KRUPP

Chapa de apoyo del gualderin.

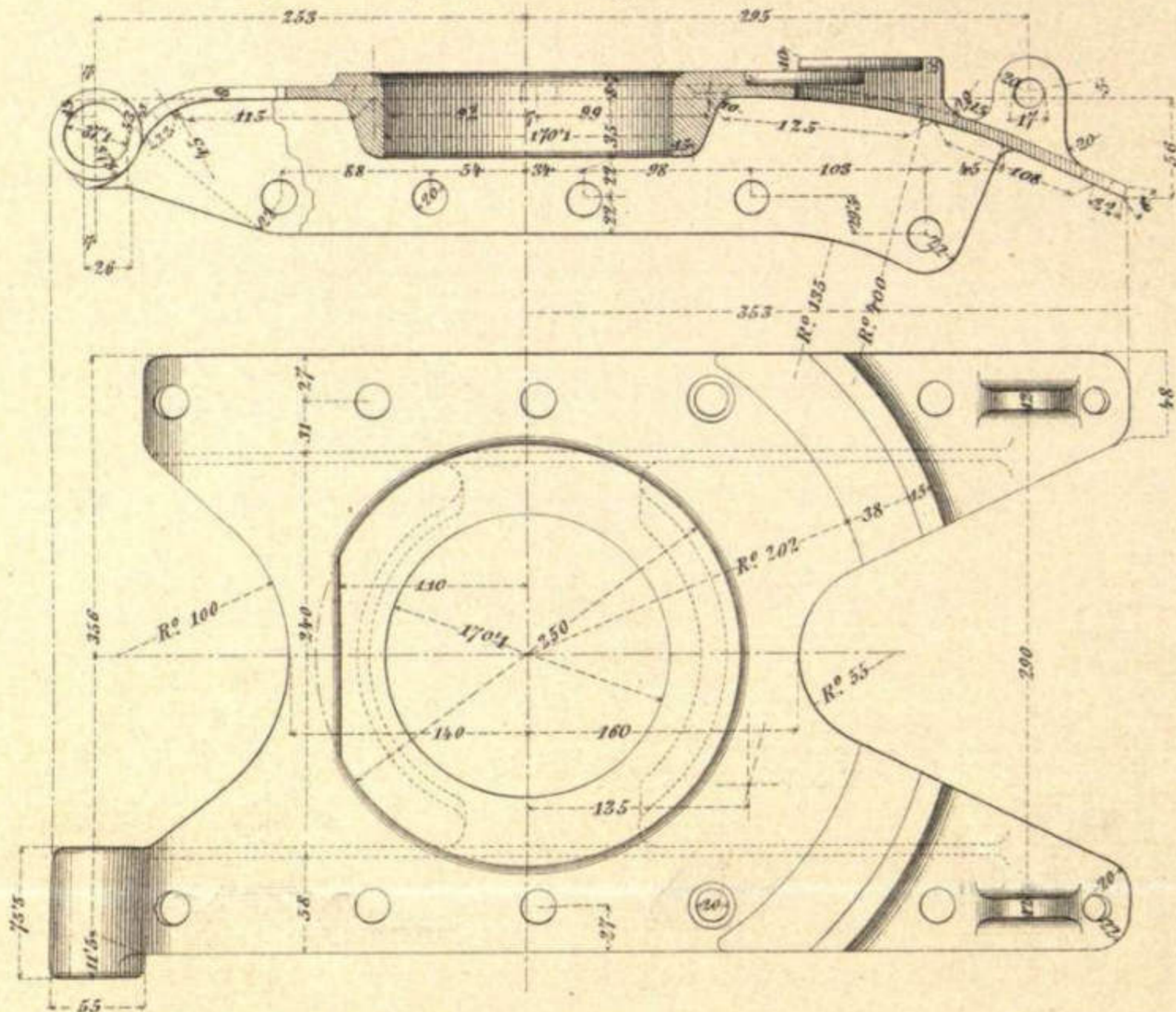

DETALLE S.
Escala 2/10.

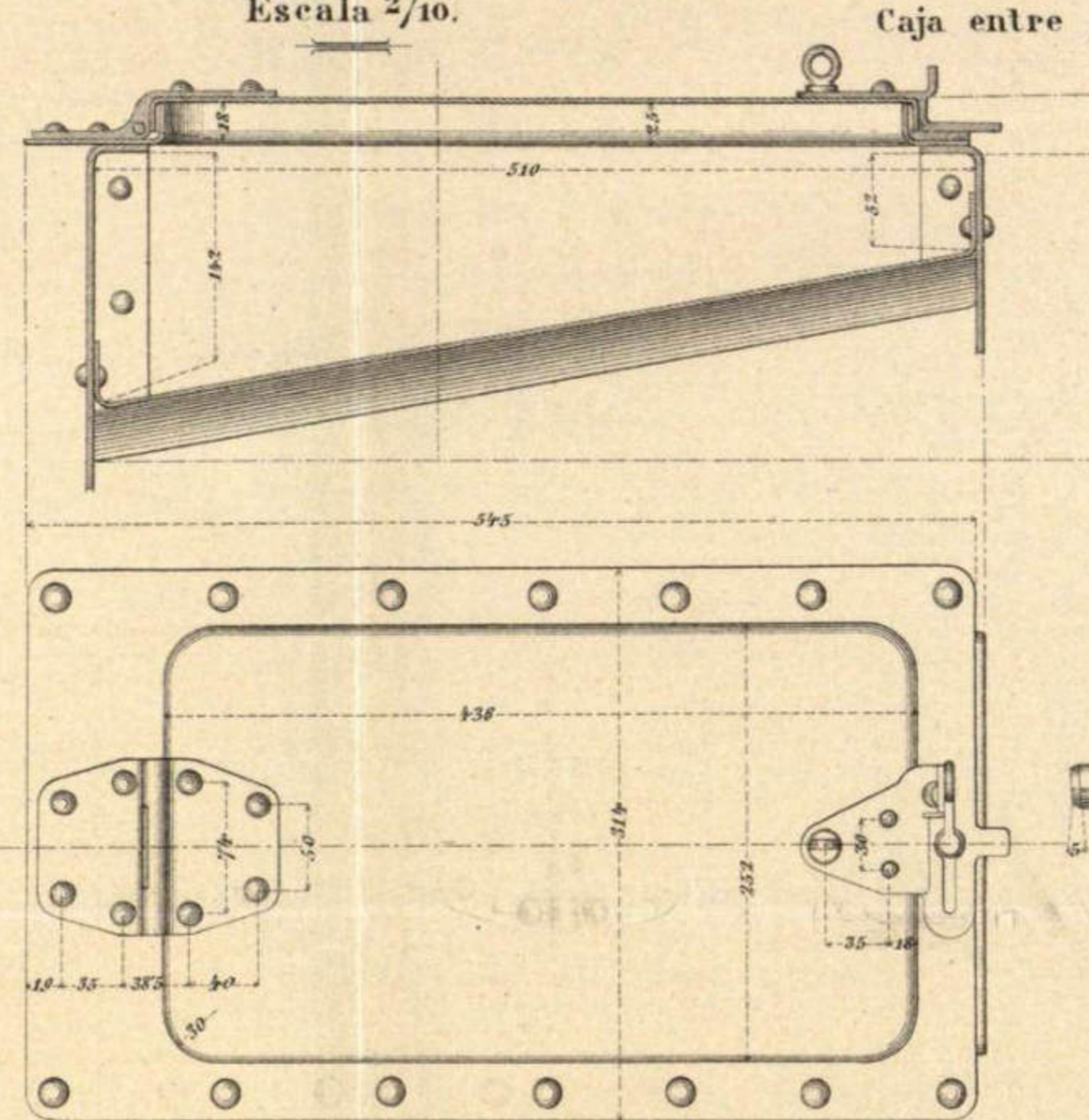

Caja entre gualderas.

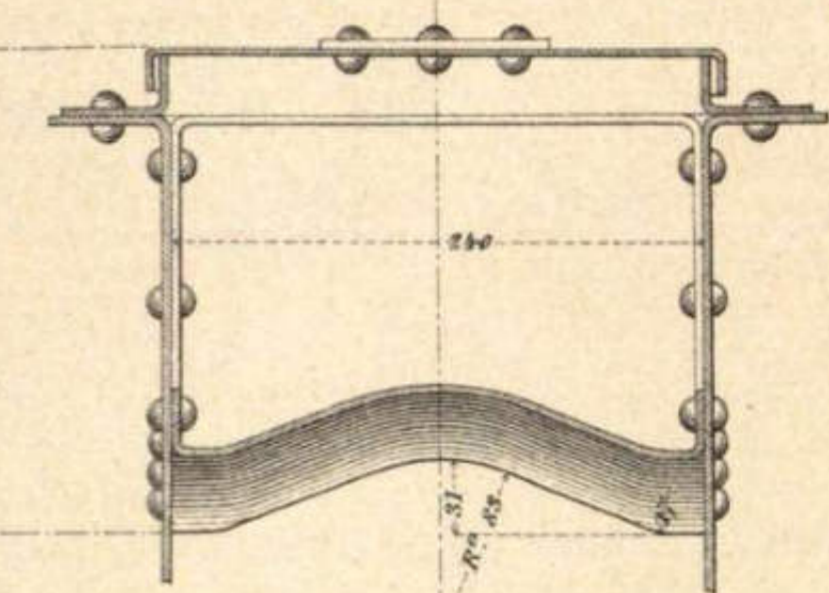

Telera del cerrojo.

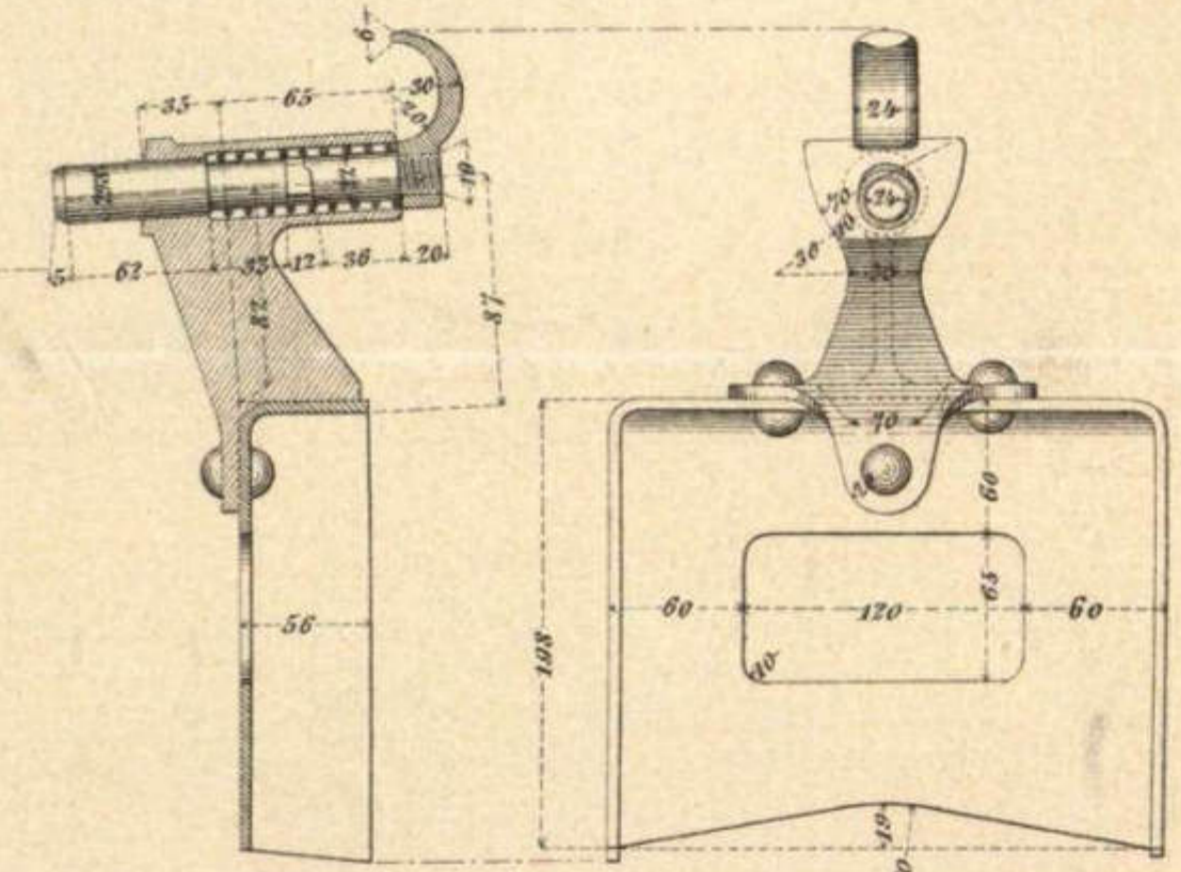

Argollón de contera.

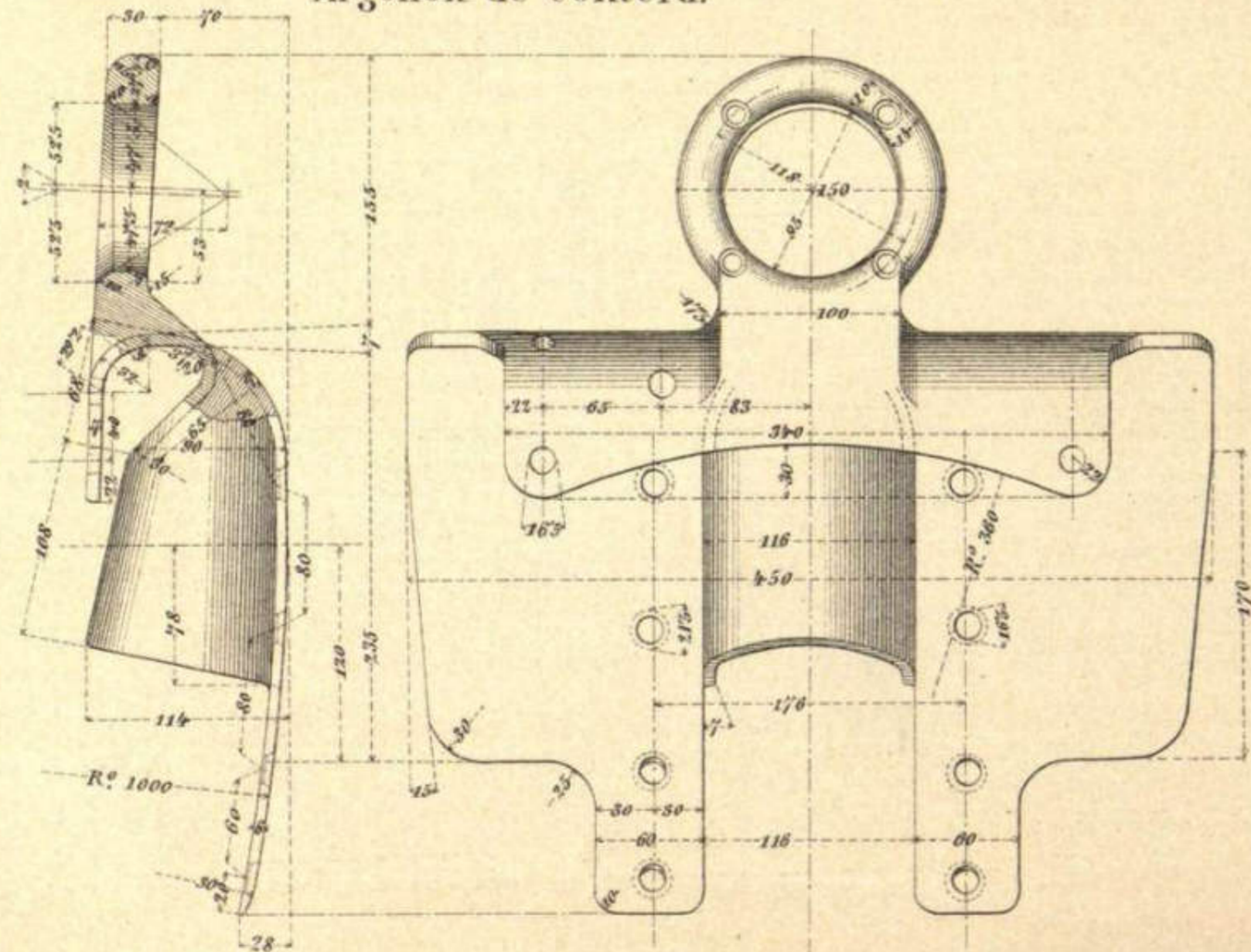

Rozaderos.

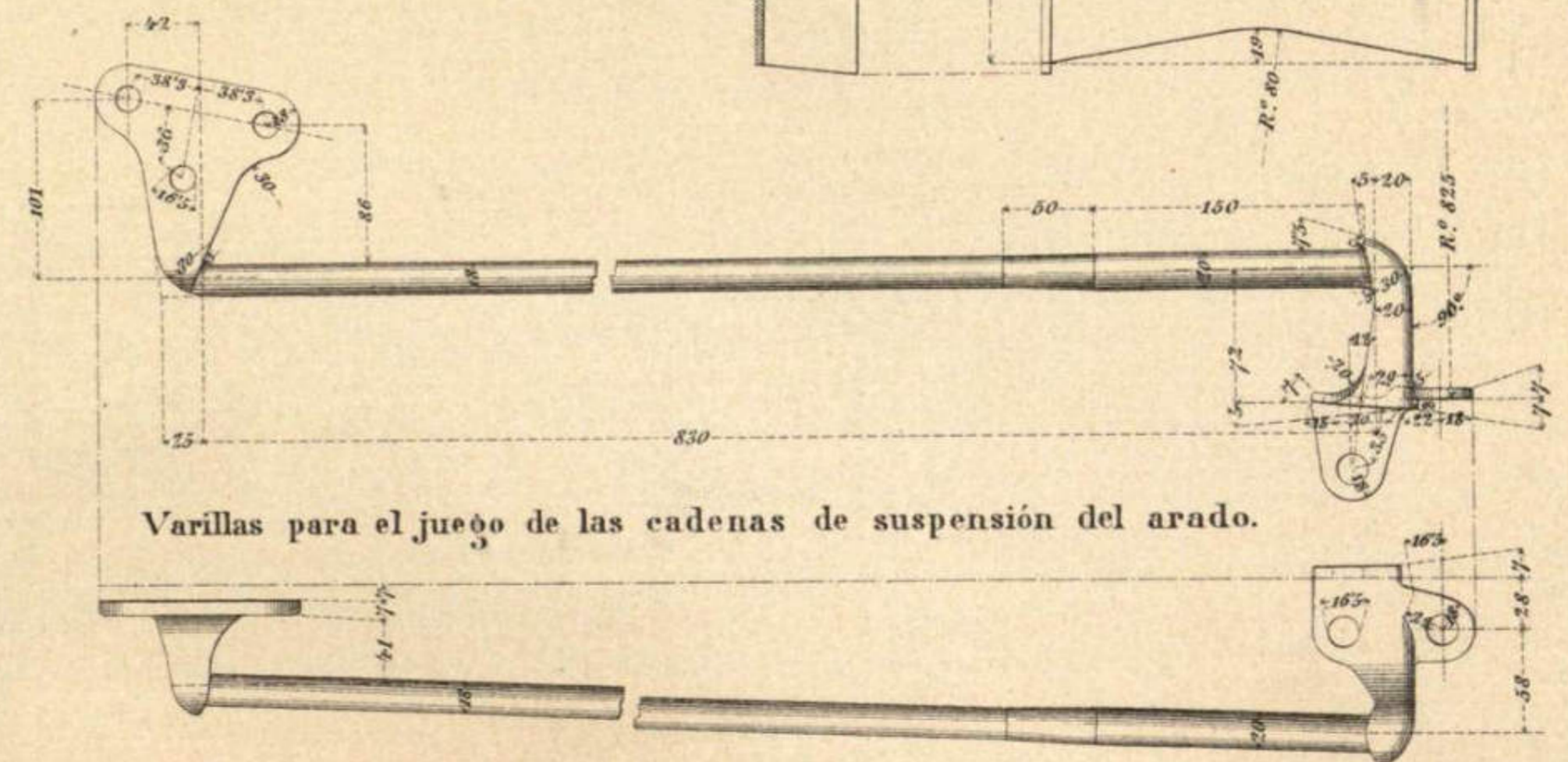
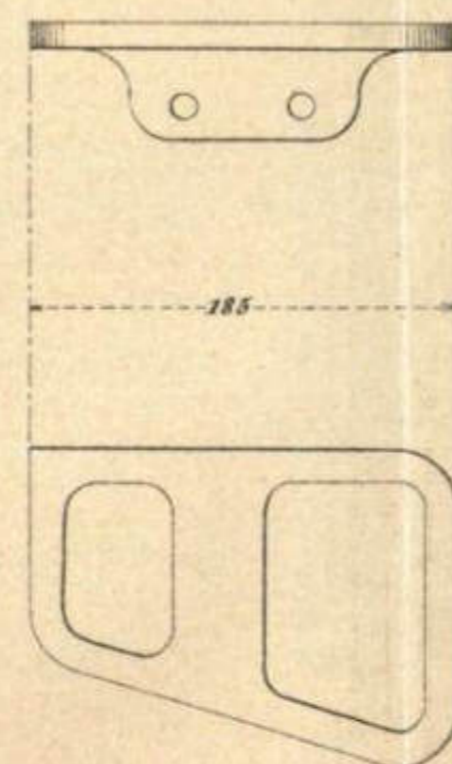

Varillas para el juego de las cadenas de suspensión del arado.

CUREÑA PARA CAÑON T. r. DE 7'5 cm. DE CAMPAÑA KRUPP

APARATO DE PUNTERIA EN ALTURA

Escala $\frac{5}{10}$.

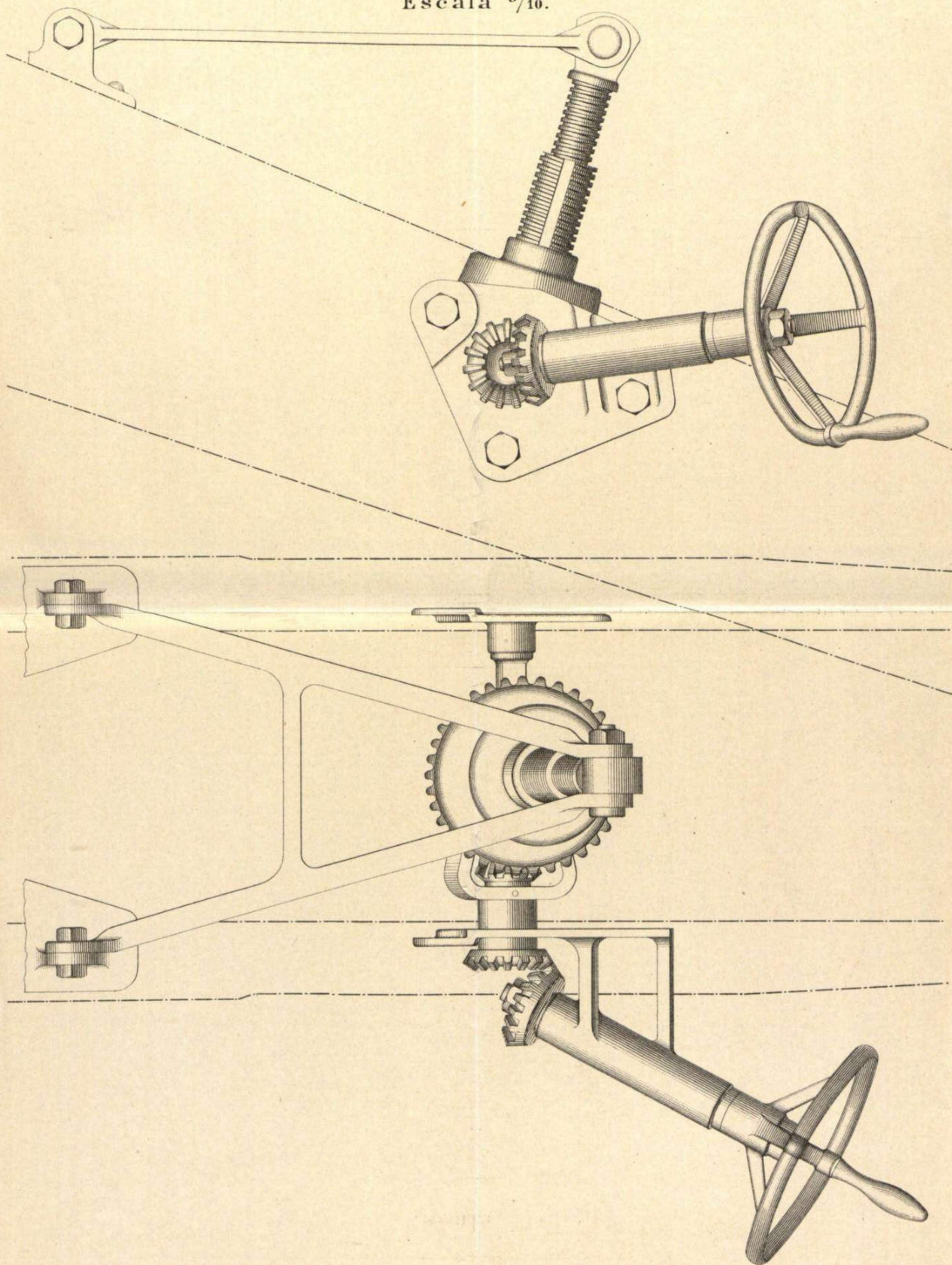

CUREÑA PARA CAÑÓN T. r. DE 7'5 cm. DE CAMPAÑA KRUPP

DETALLES DEL APARATO DE PUNTERIA EN ALTURA

Volante de punteria con su manivela.

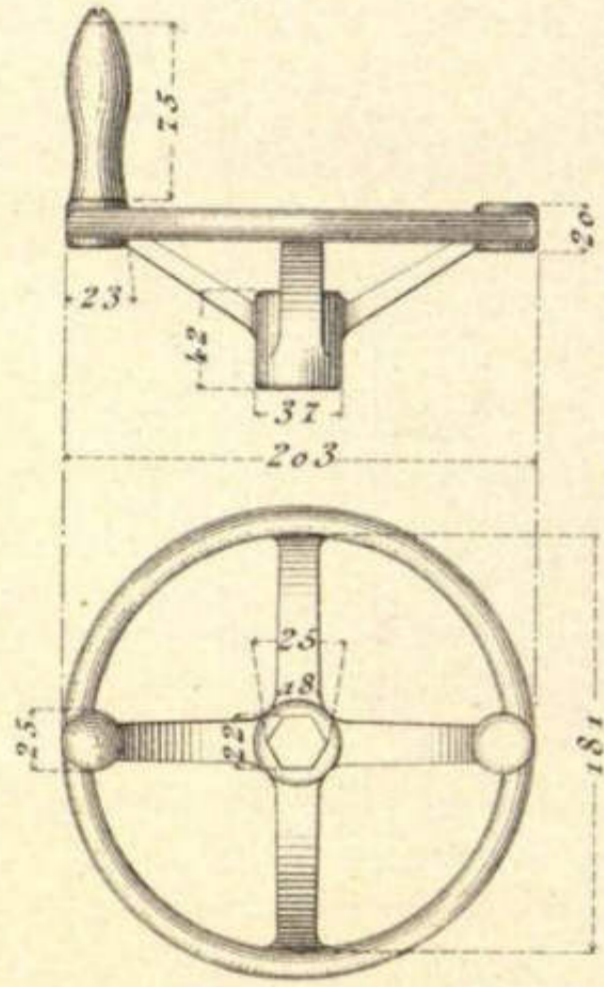

Piñon interior. (5/10)

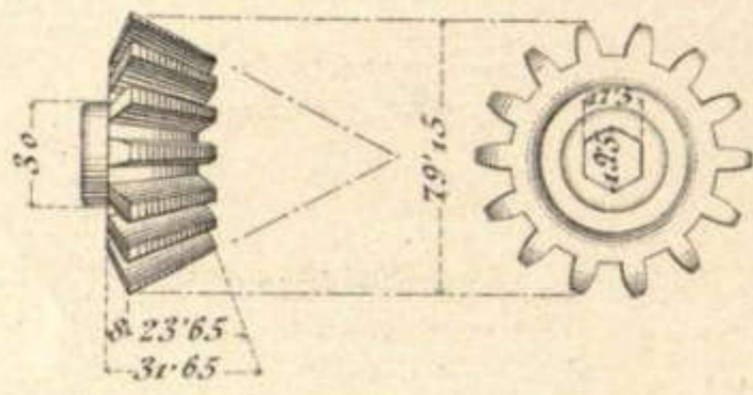

Corona de bronce. (5/10)

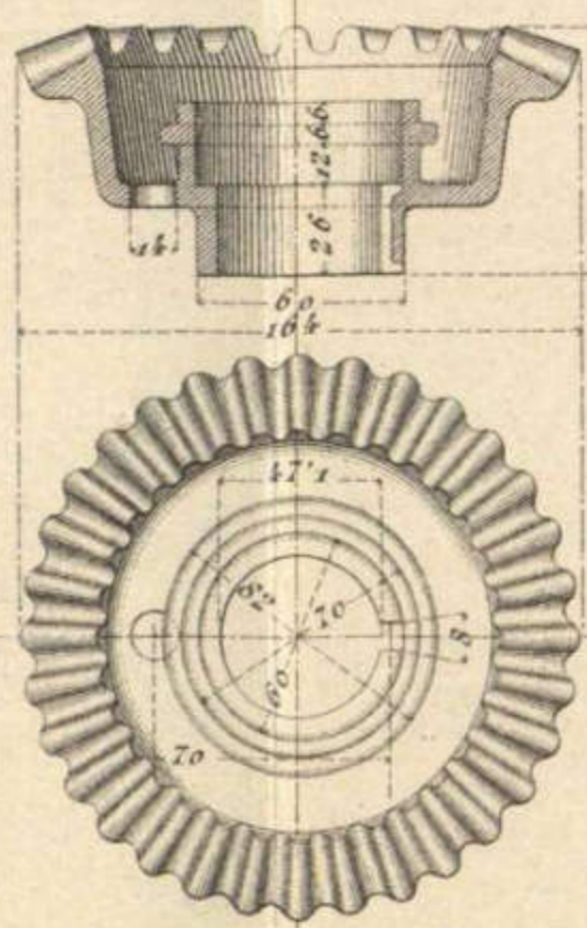

Tornillo husillo. (2/10)

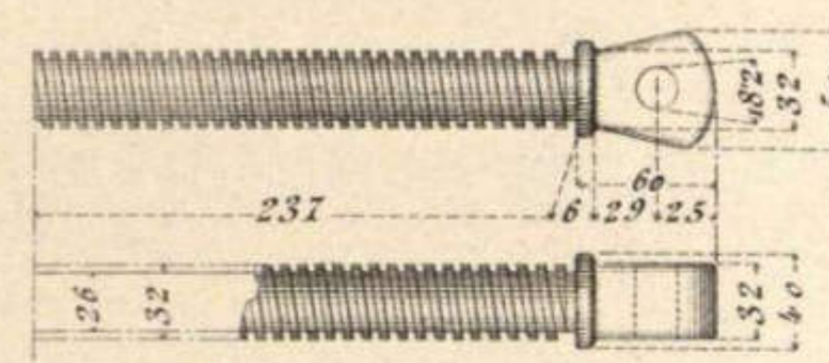

Soporte (5/10)

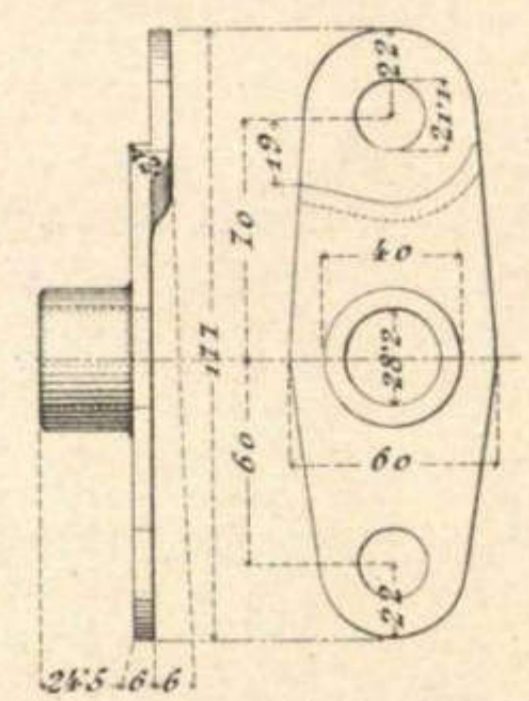

Piñon que engrana en el eje (5/10)

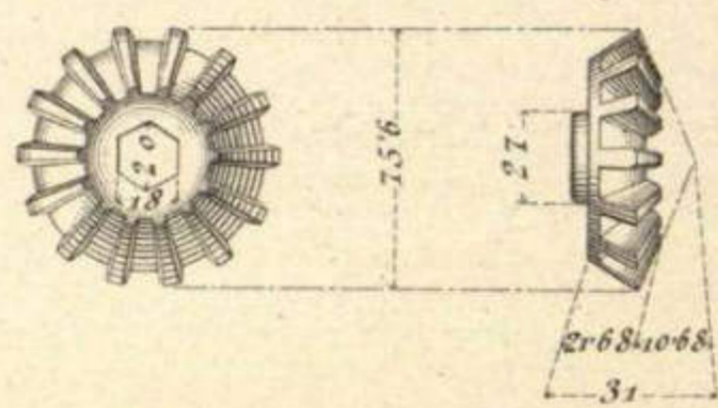

Husillo. (2/10)

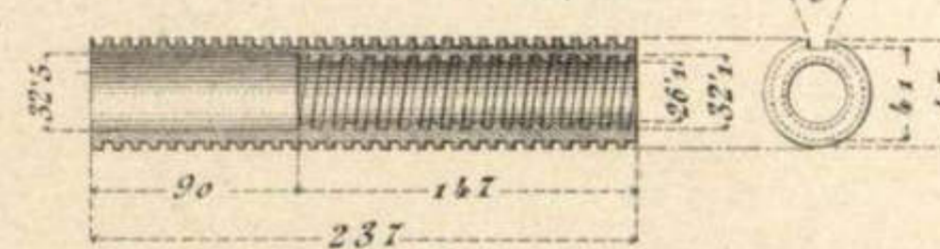

Manguitos (2/10)

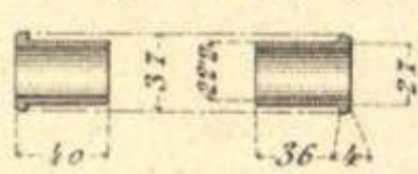

Tuerca (5/10)

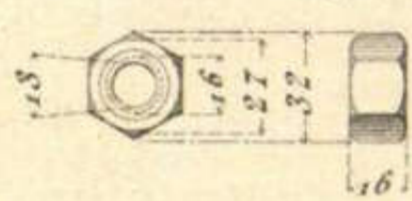

Arbol (5/10)

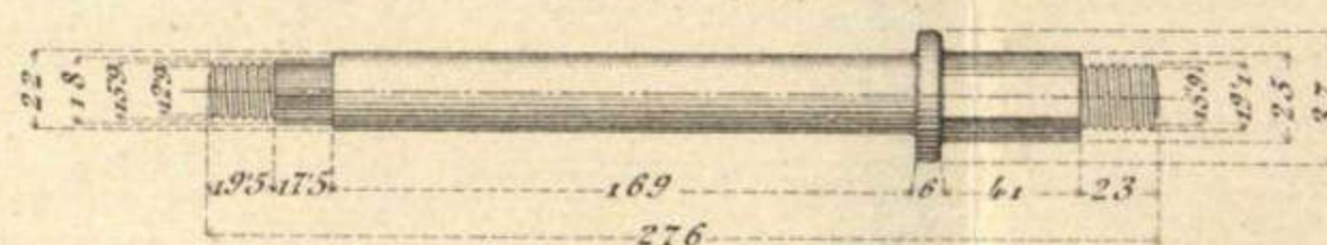

Tuerca. (5/10)

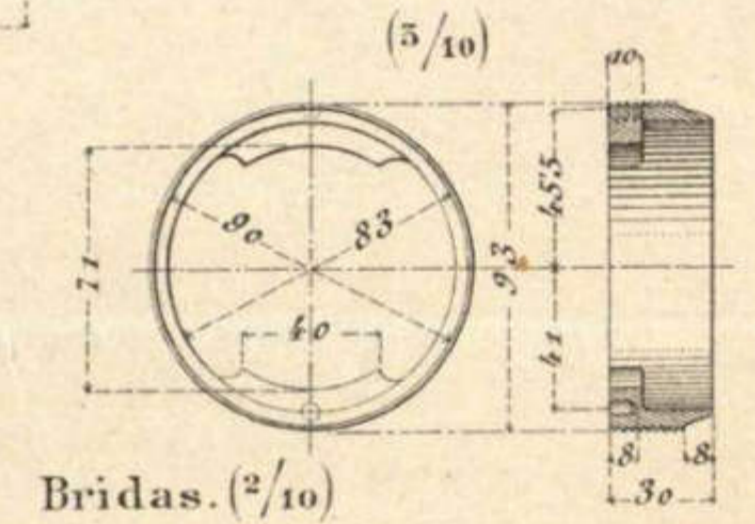
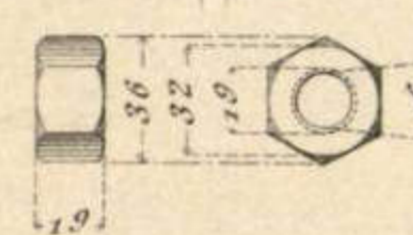

Soporte (2/10)

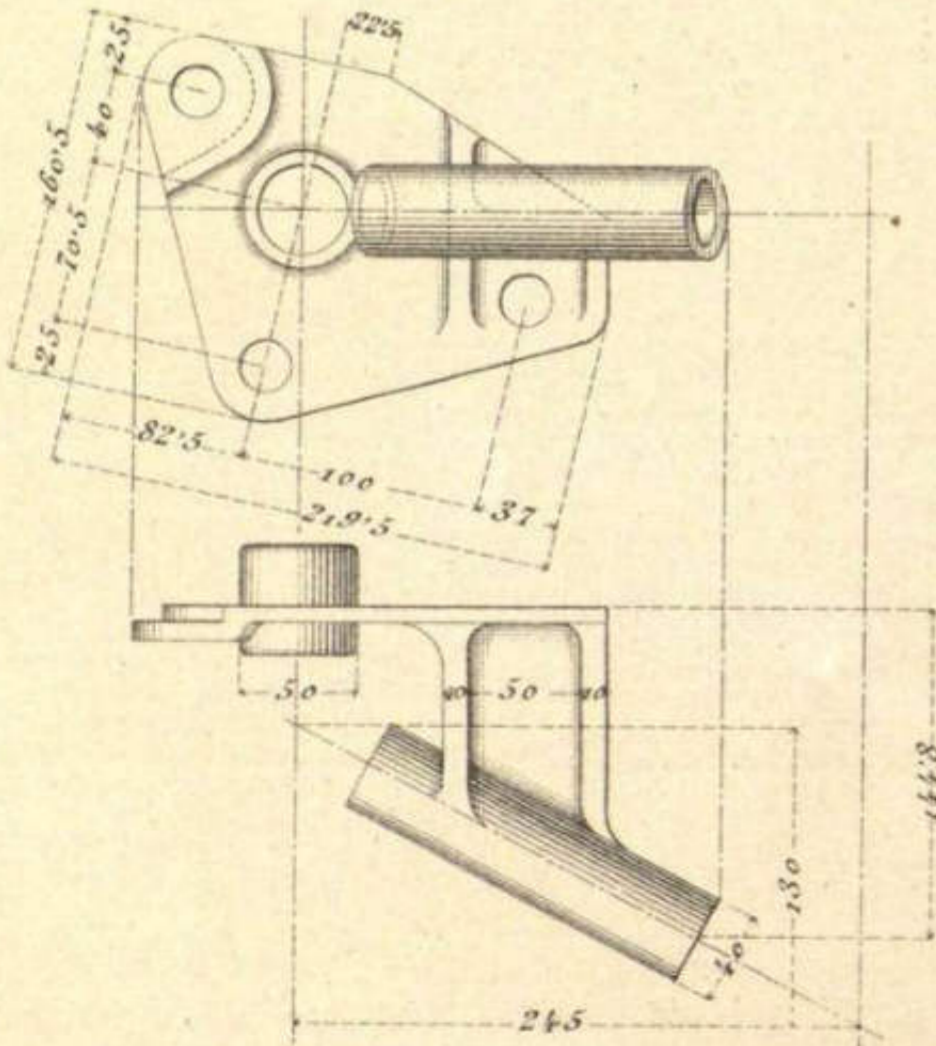

Tuerca del aparato (5/10)

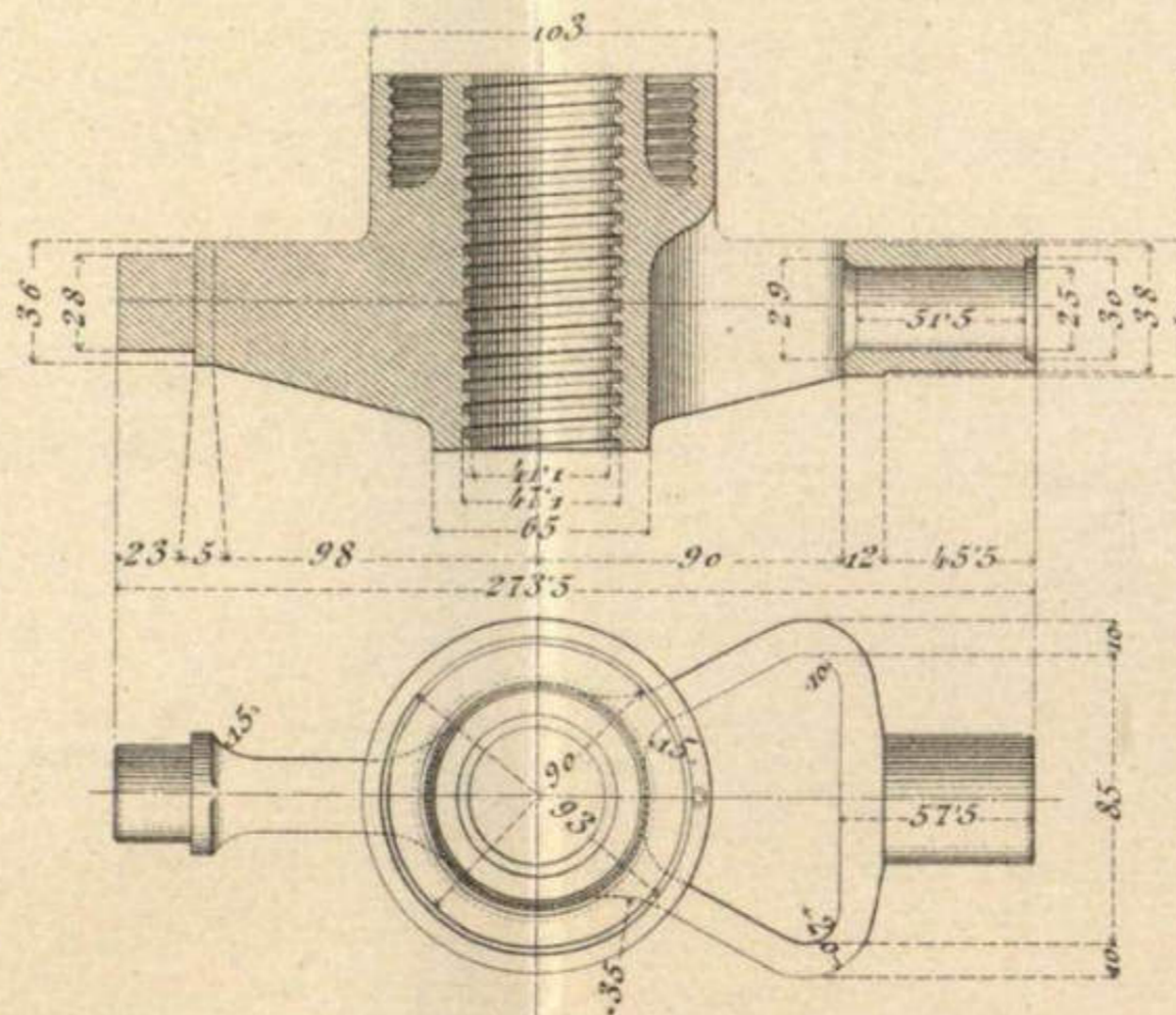

Tuerca de sujecion (5/10)

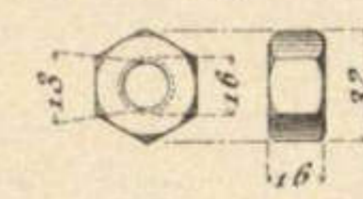

Eje. (5/10)

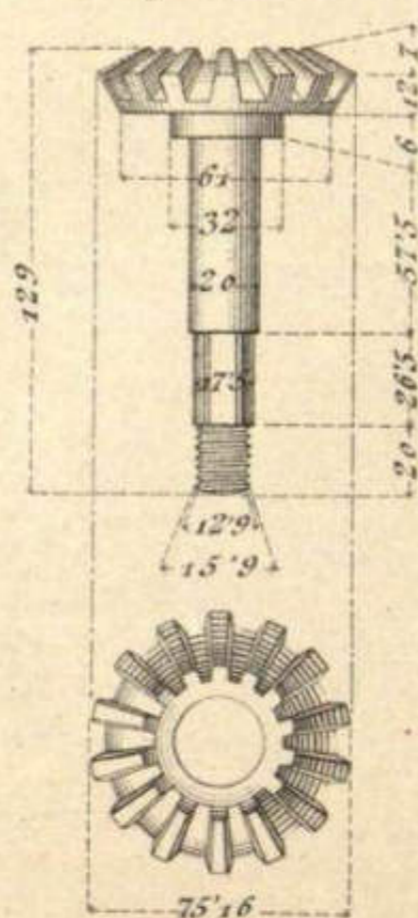

Pernos (4/10)

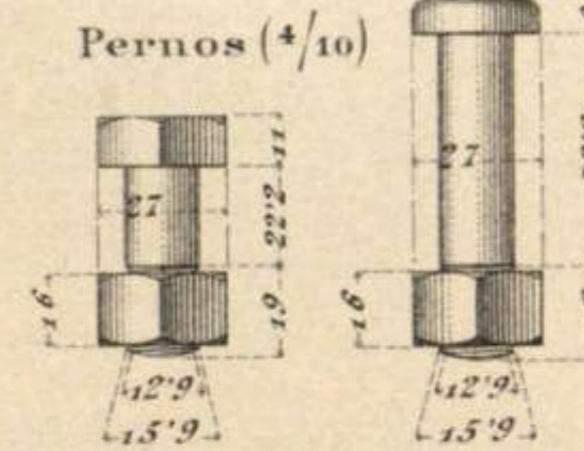

Bridas. (2/10)

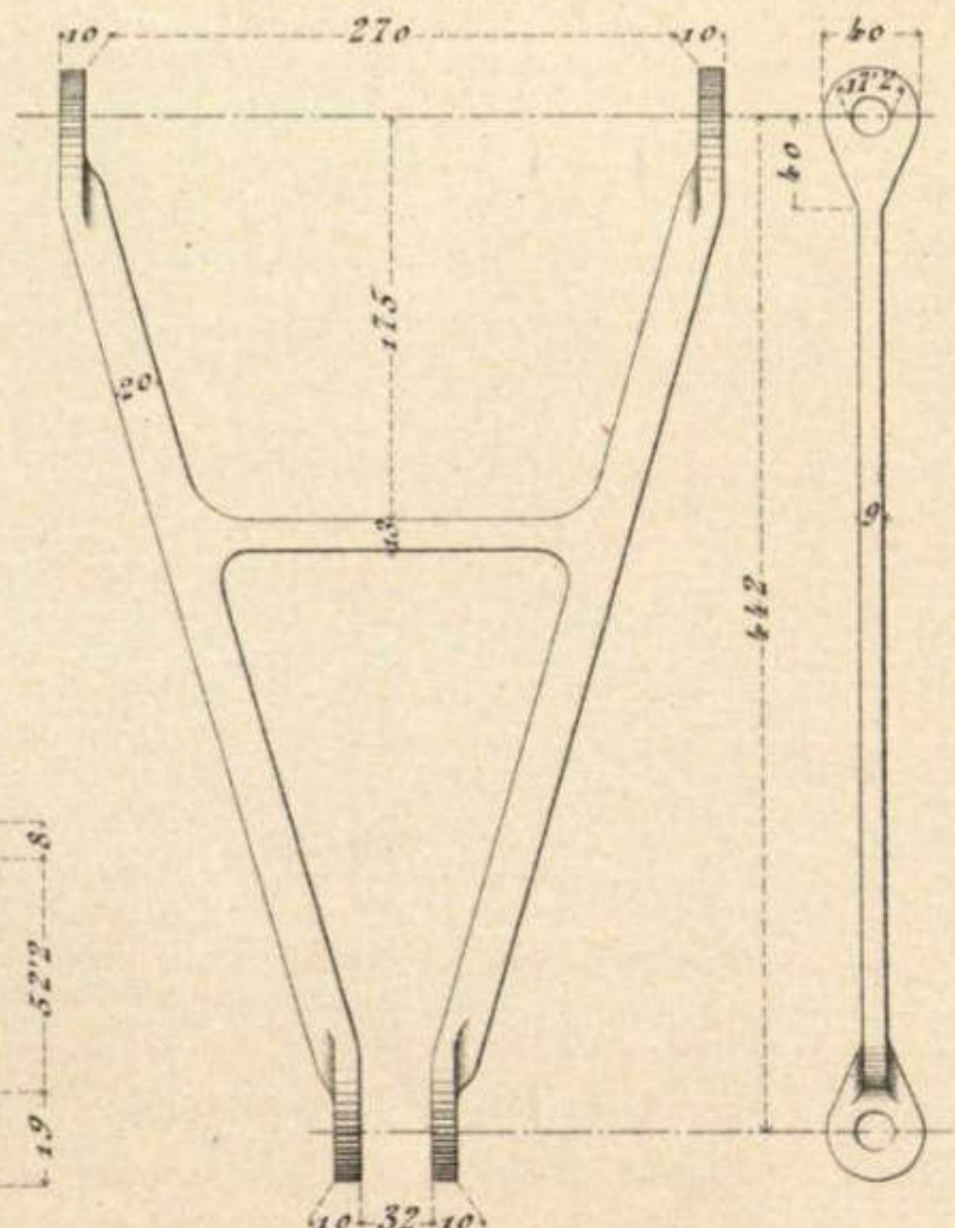

CUREÑA PARA CAÑÓN T. r. DE 7'5 cm. DE CAMPAÑA KRUPP

FRENO DE MARCHA.

Escala $\frac{15}{10}$.

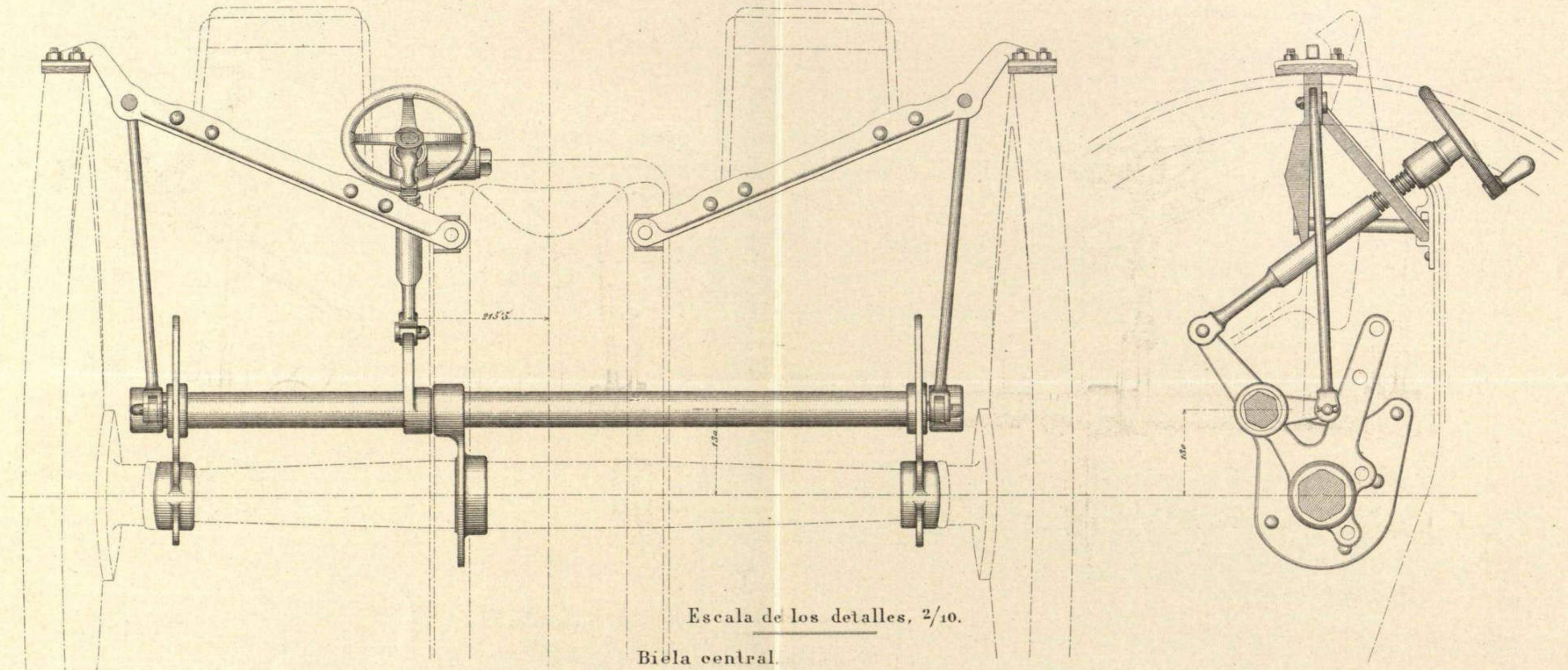

Escala de los detalles, $\frac{2}{10}$.

Bielas laterales.

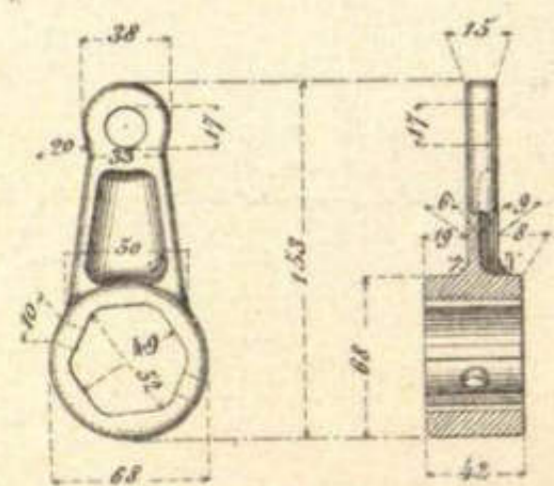

Pernos de unión y giro.

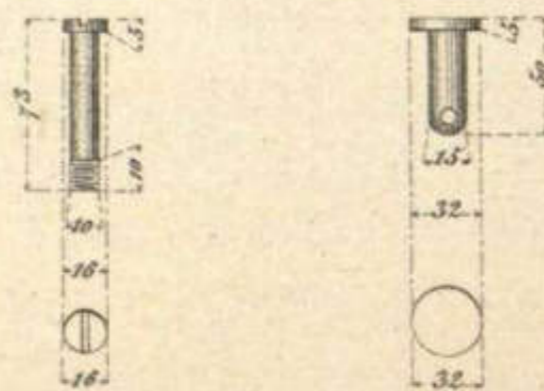

Biela central.

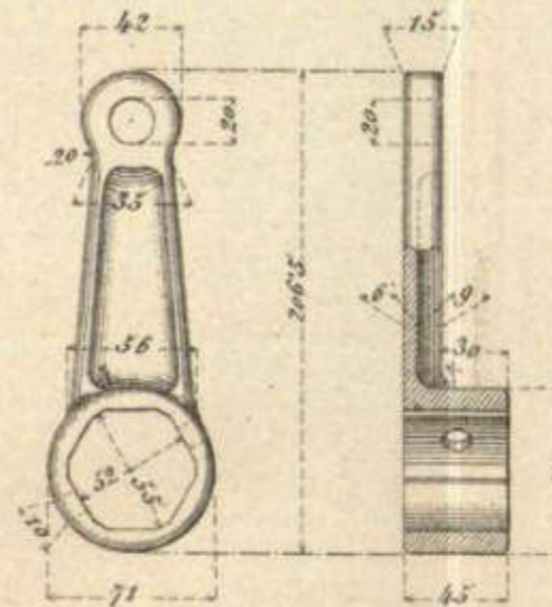

Perno de unión y giro.

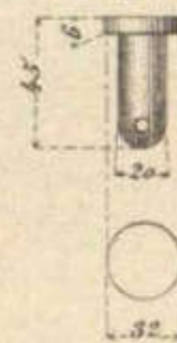

Bridas.

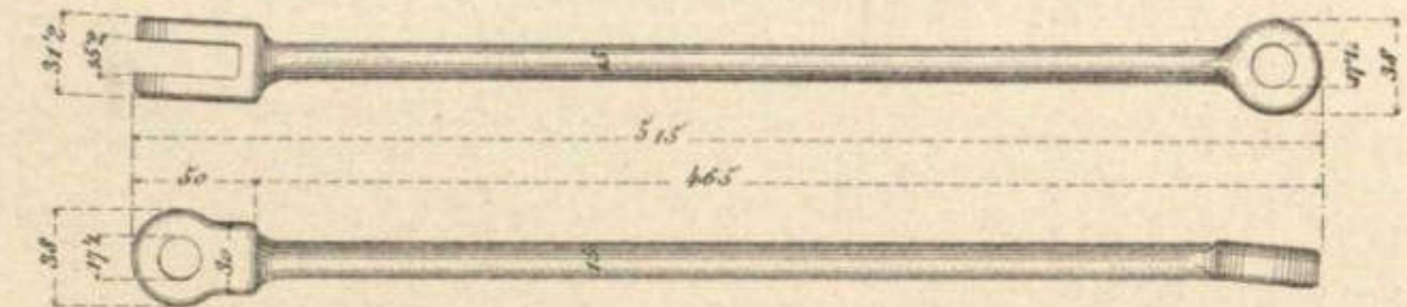

CUREÑA PARA CAÑÓN T. r. DE 7'5 cm. DE CAMPAÑA KRUPP

FRENO HIDRÁULICO.

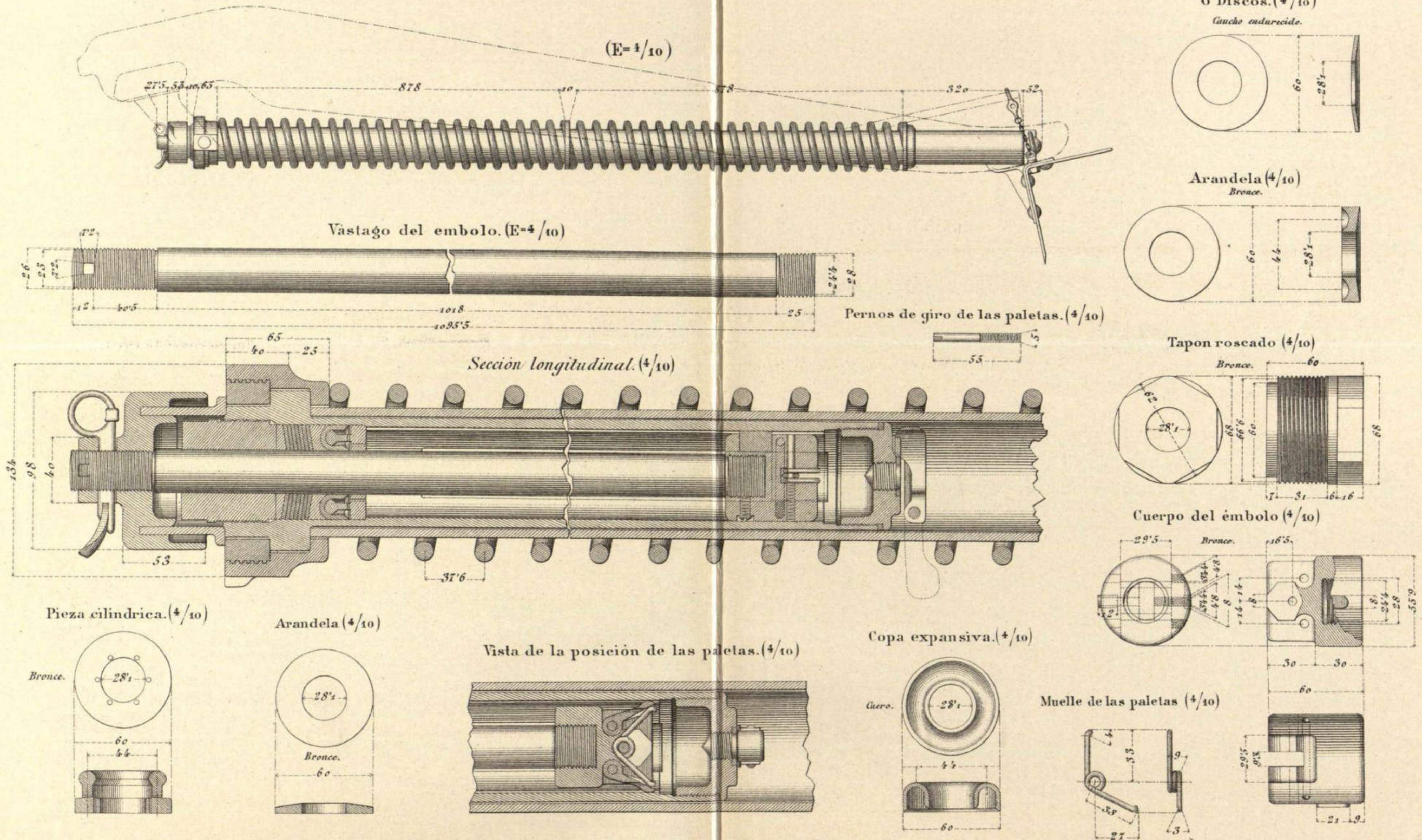

CUREÑA PARA CAÑÓN T. r. DE 7'5 cm. DE CAMPAÑA KRUPP

DETALLES DEL FRENO HIDRAULICO

Collar porta-muñones (4/10)

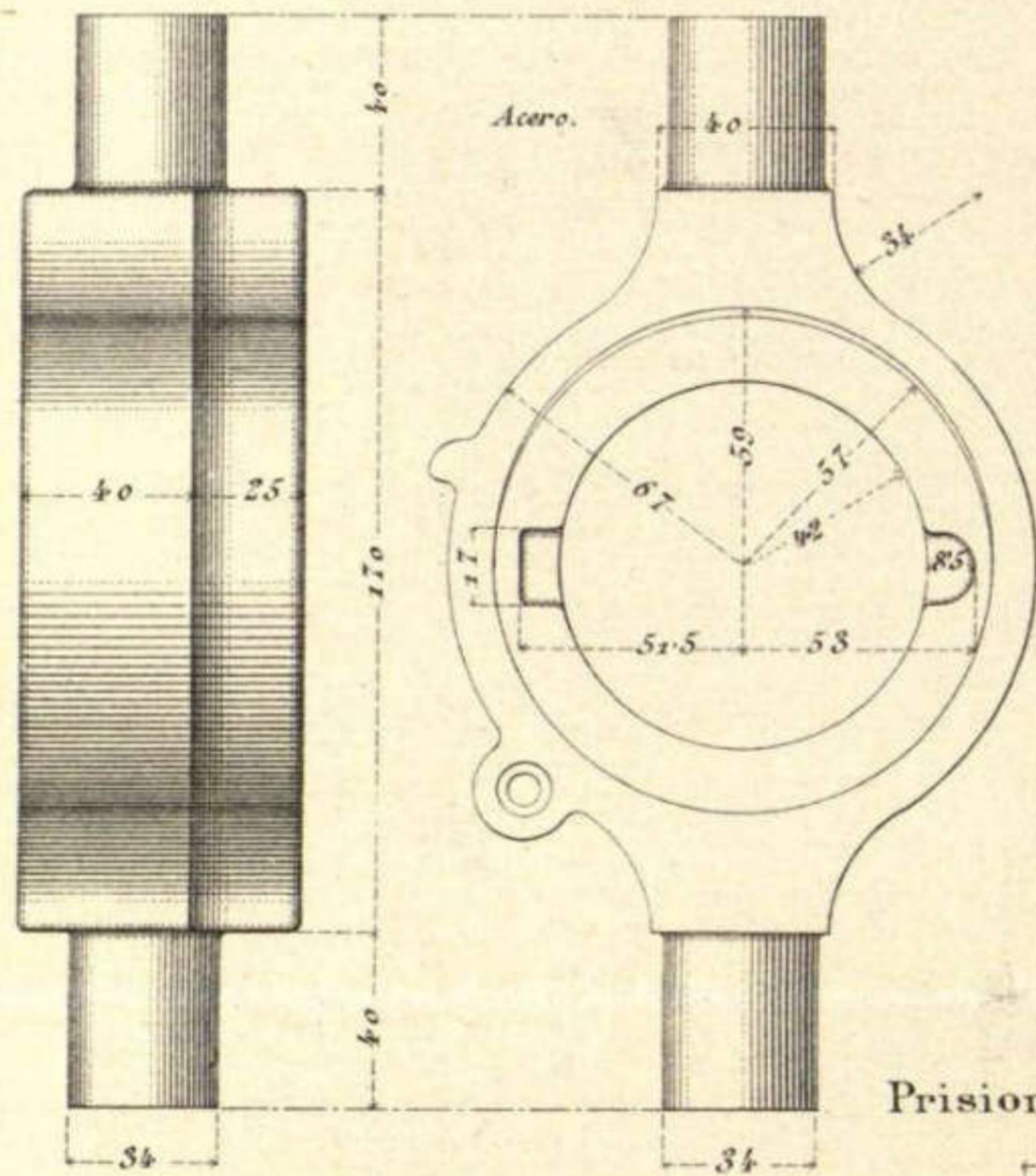

Cuerpo del freno (4/10)

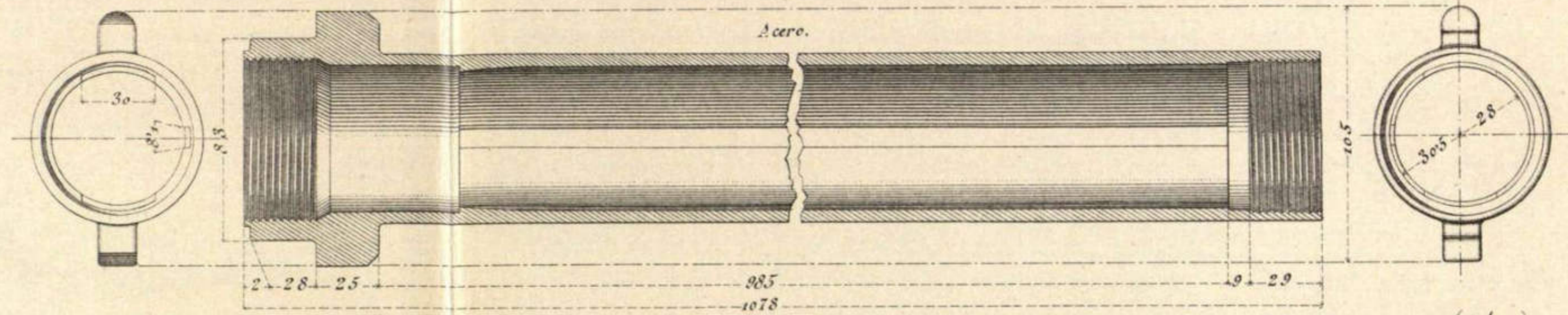

Cabeza de la envuelta. (4/10)

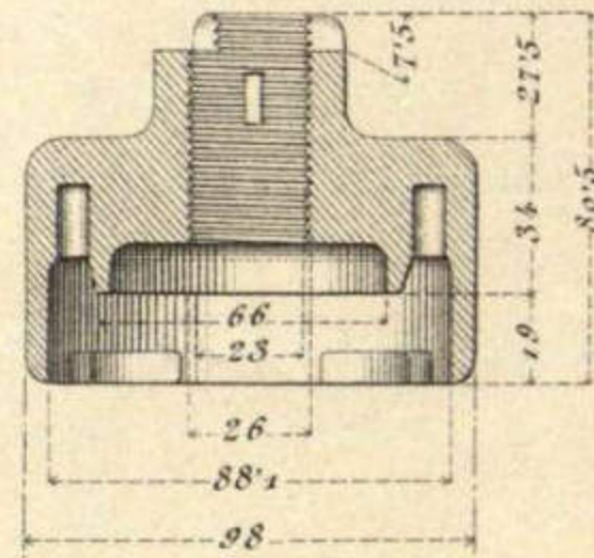

Chaveta (5/10)

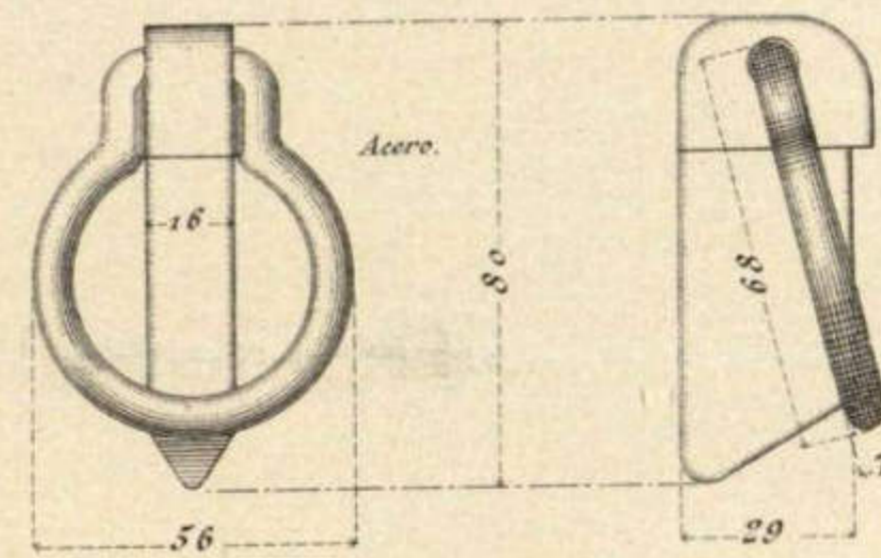

Tapon roscado. (5/10)

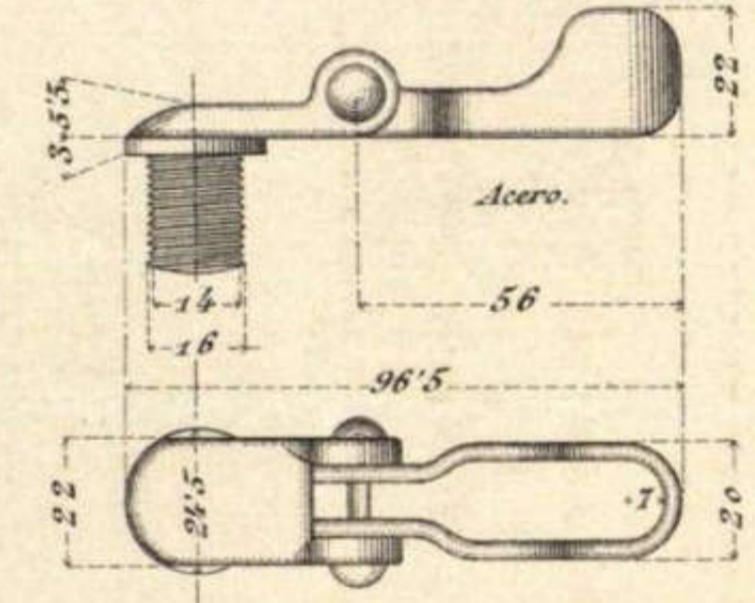

Prisionero. (1/1)

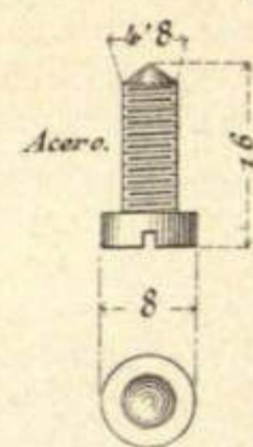

Chaveta con cadenilla. (5/10)

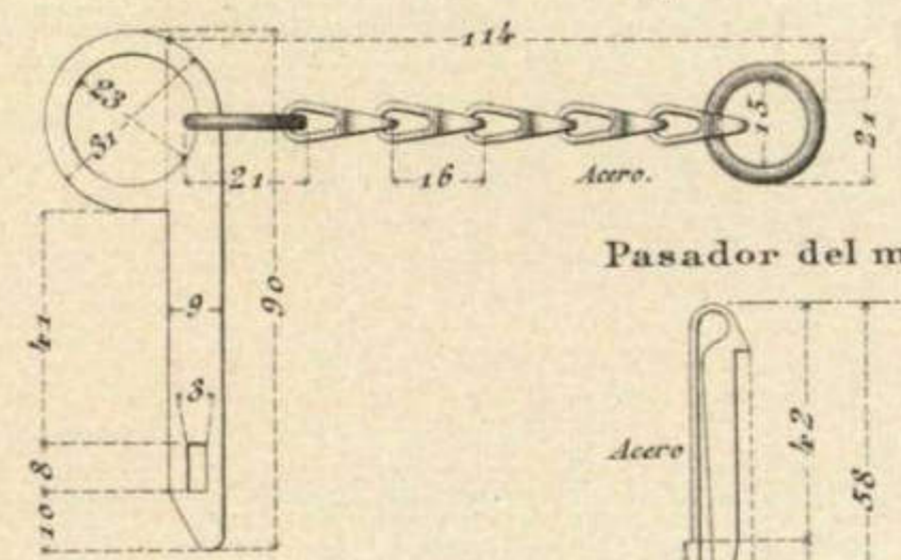

Anillo de cierre (4/10)

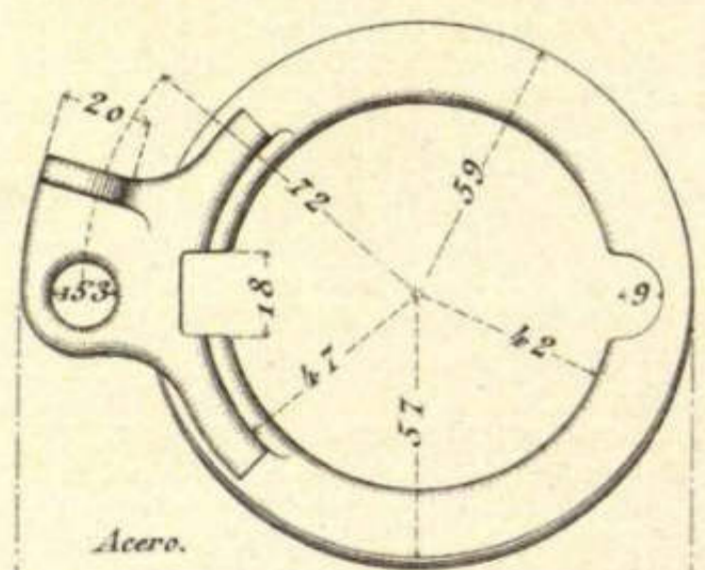

2 Paletas. (4/10)

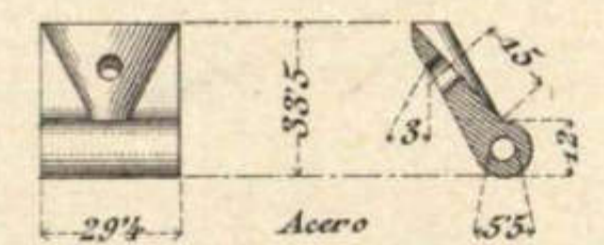

Pasador del muelle (5/10)

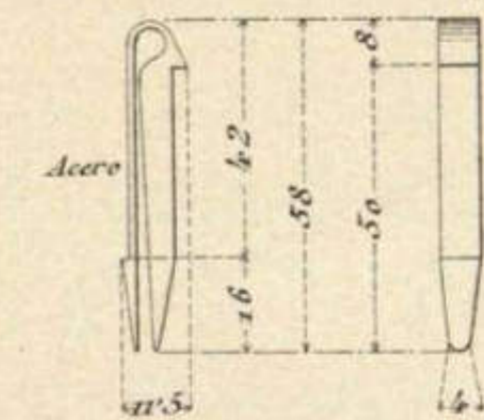

2 Pernos de giro de las paletas. (6/10)

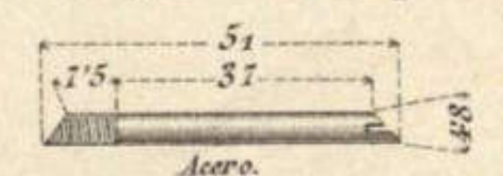

Envuelta del cuerpo del freno. (2/10)

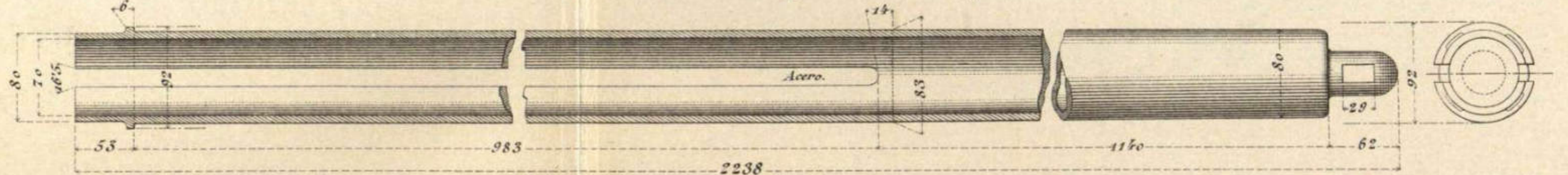

CUREÑA PARA CAÑÓN T. r. DE 7'5 cm. DE CAMPAÑA KRUPP

RUEDA Y DETALLES

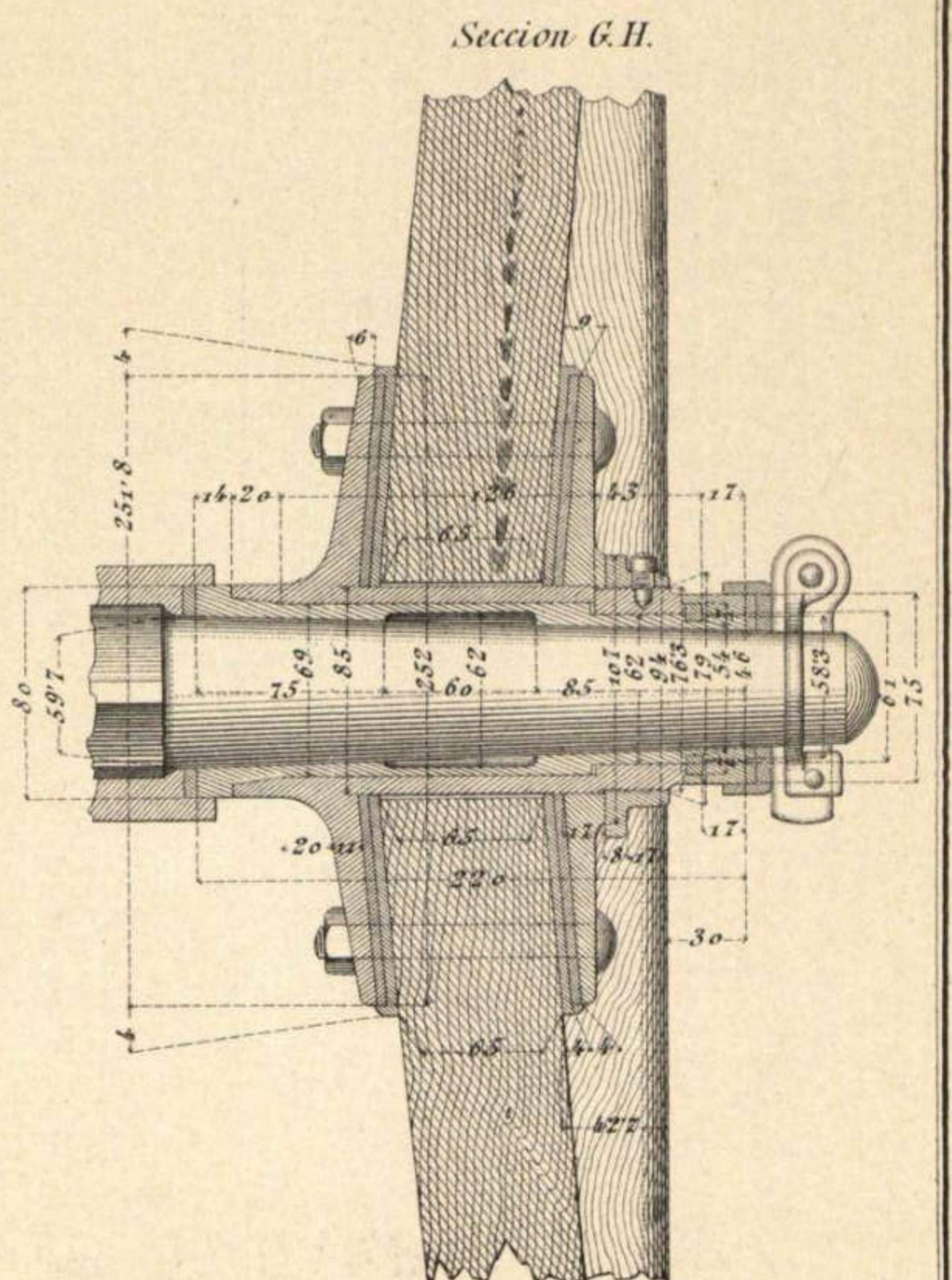
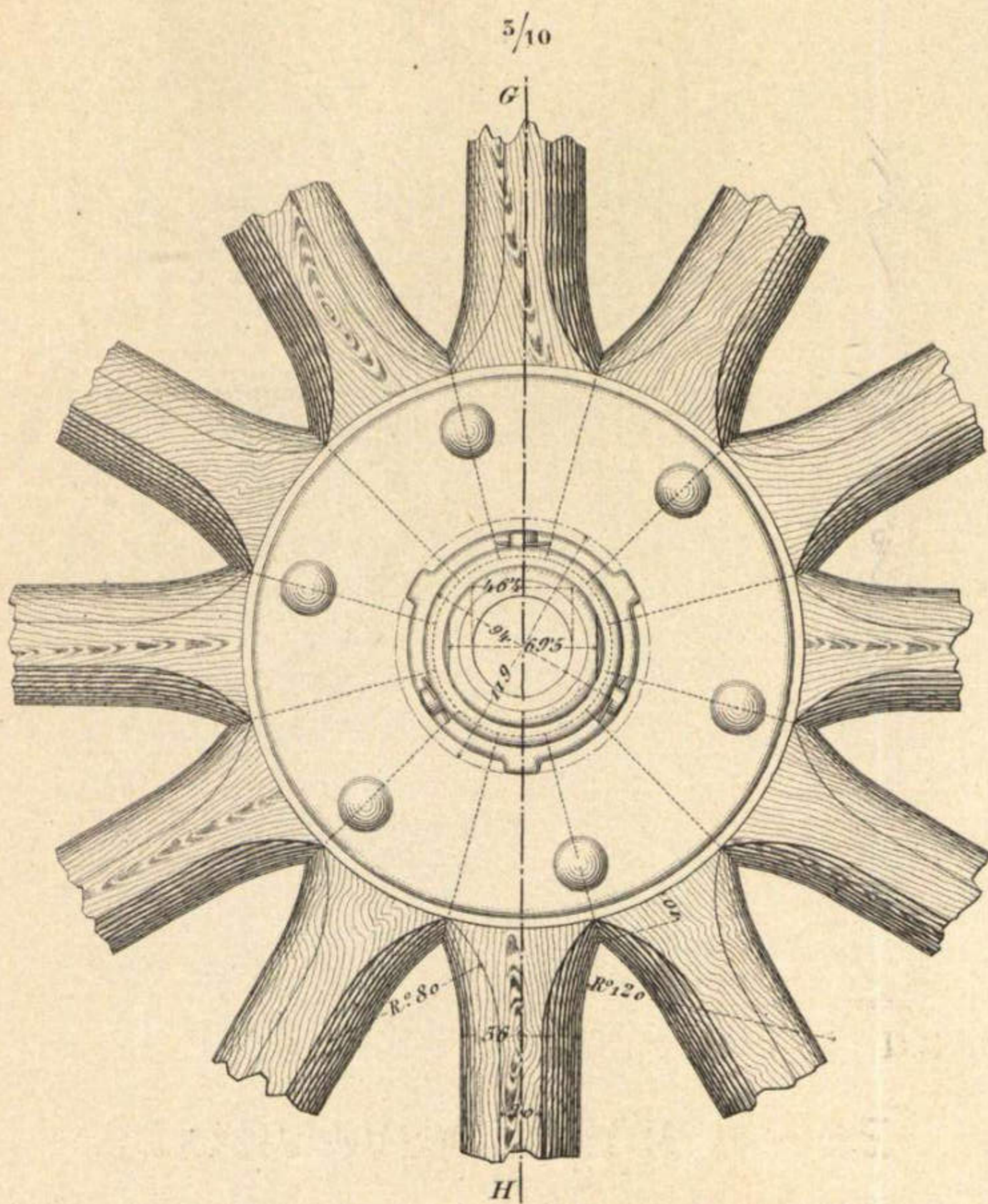
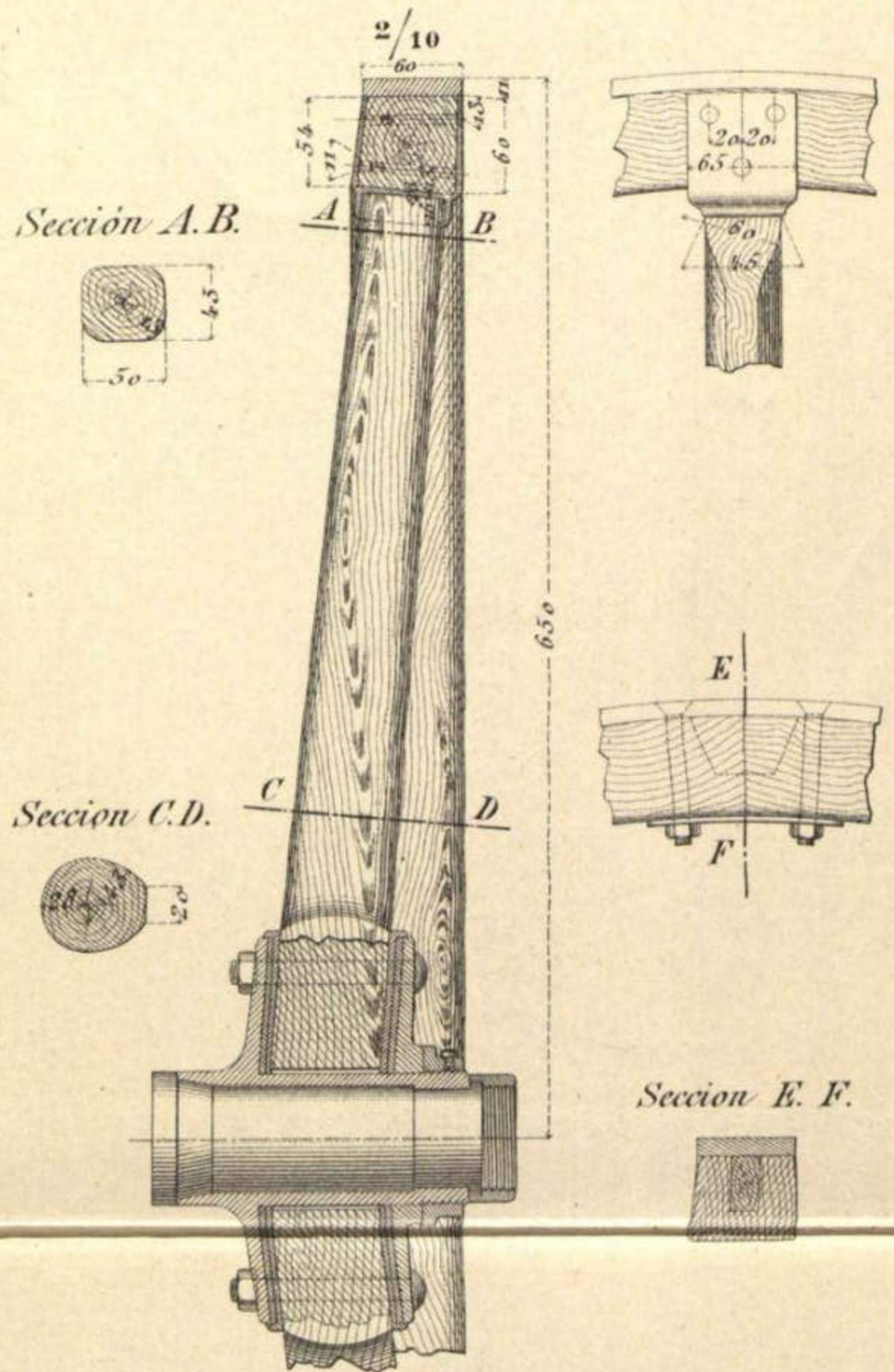
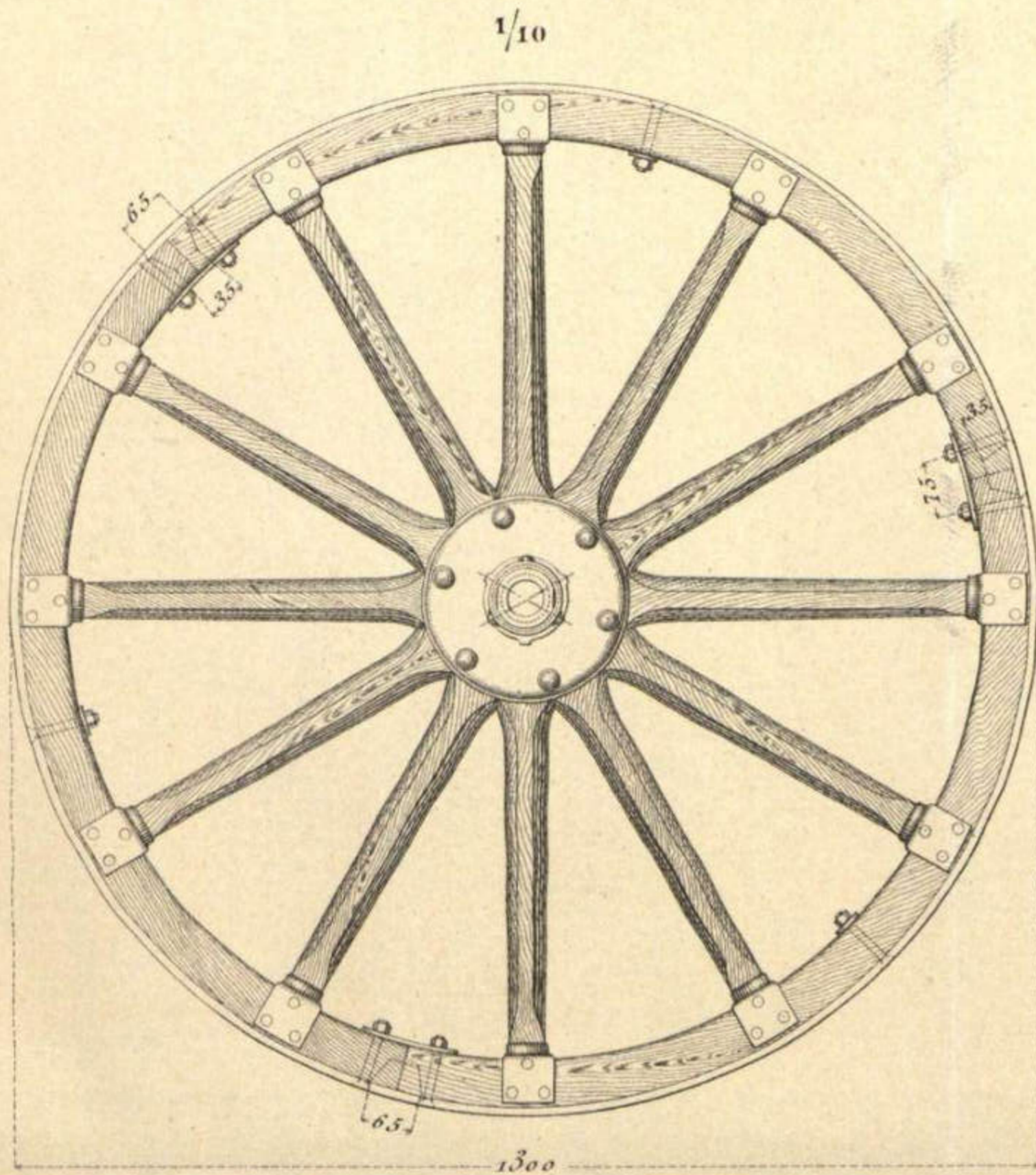

ARMON PARA MATERIAL KRUPP Y ST CHAMOND

Escala 1/10

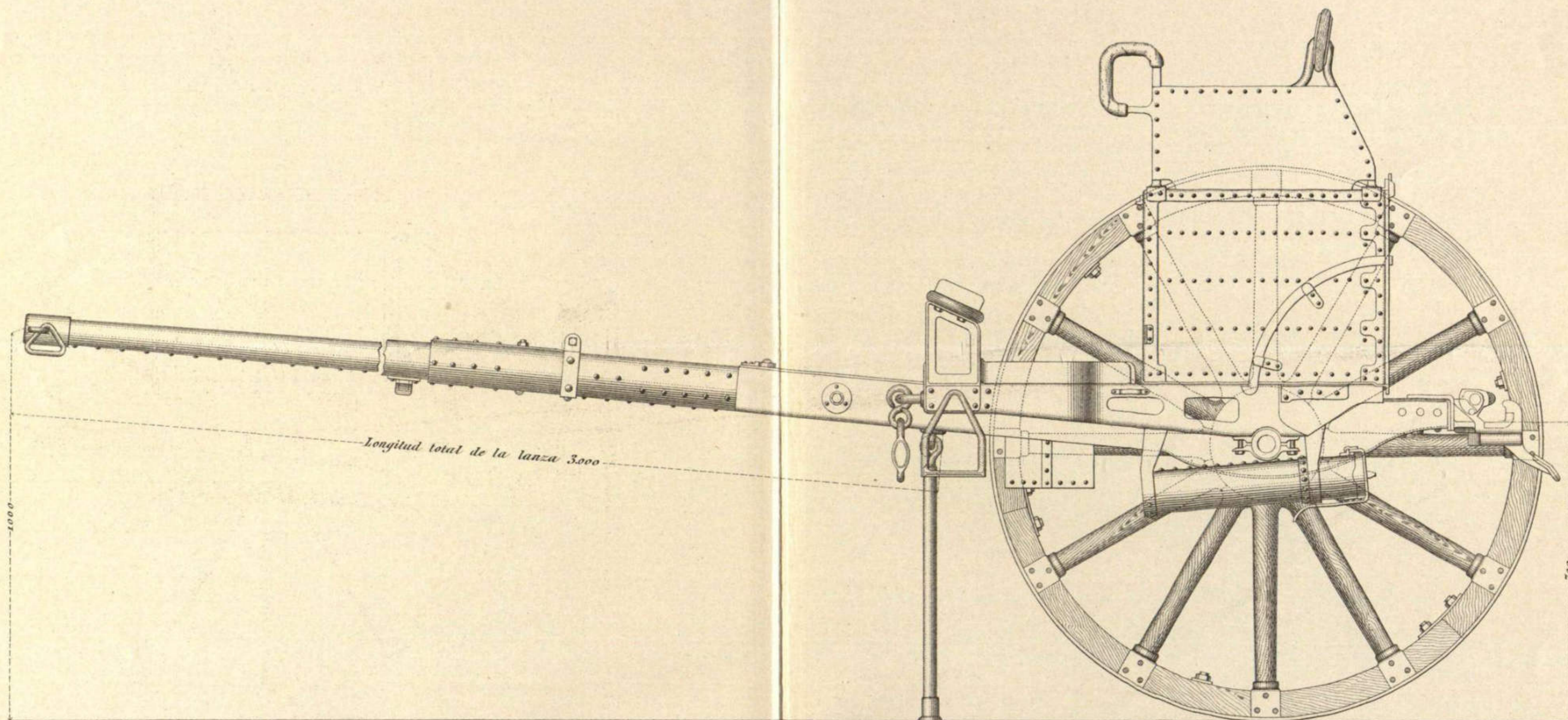

ARMON PARA MATERIAL KRUPP Y S^T CHAMOND

Escala 1/10

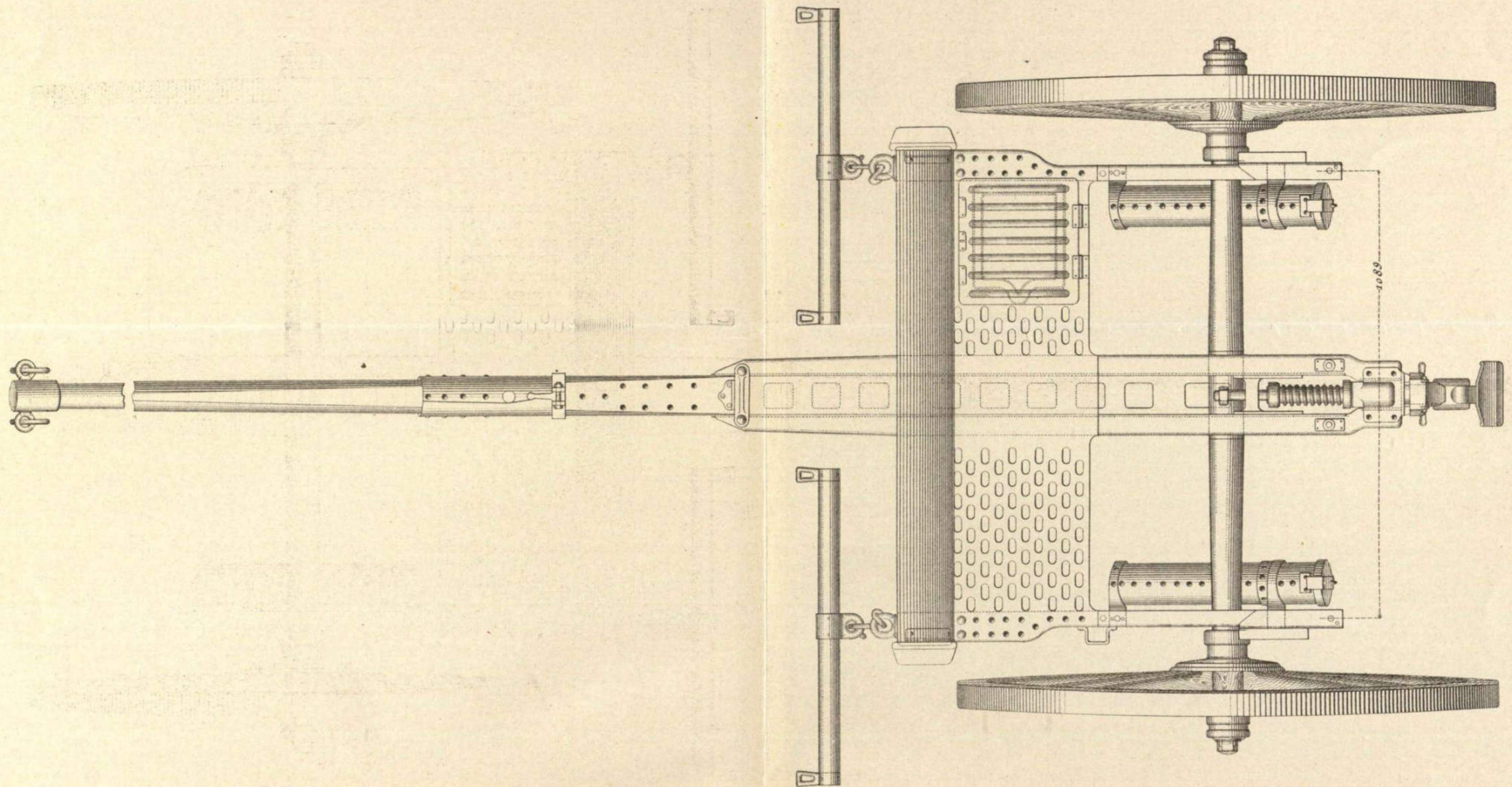

ARMON PARA MATERIAL KRUPP Y SAINT CHAMOND.

EJE Y DETALLES.

Escala 5/10

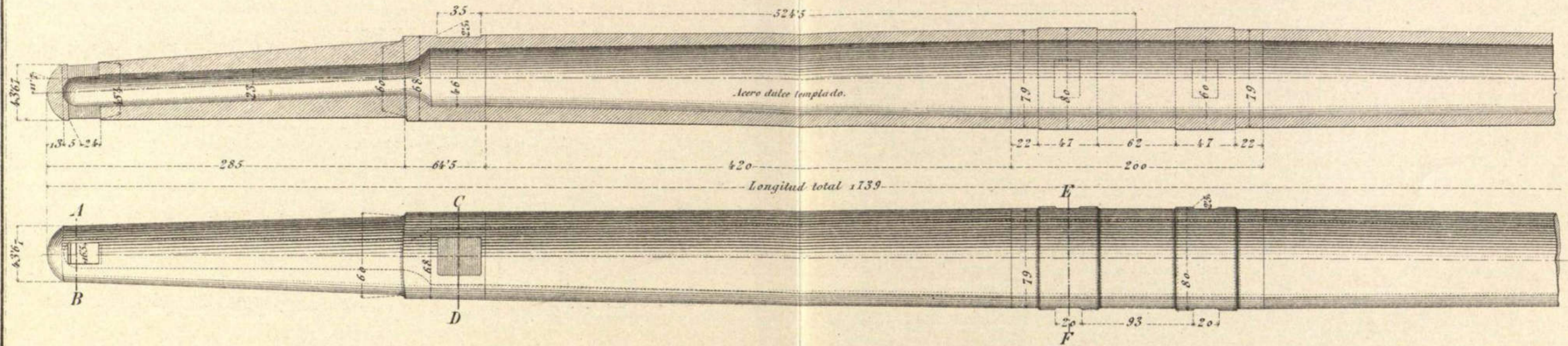

Corte por AB.

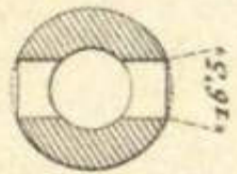

Corte por CD.

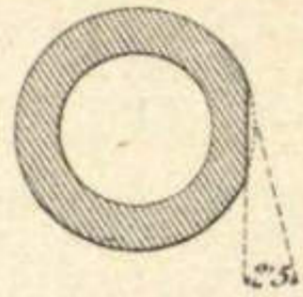

Corte por EF.

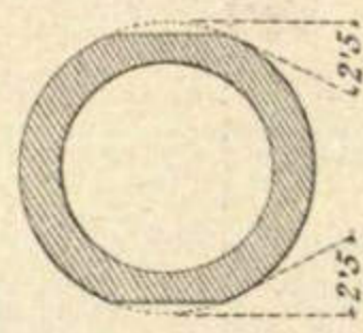

Escala de los detalles 5/10

2 Arandelas de eje interiores

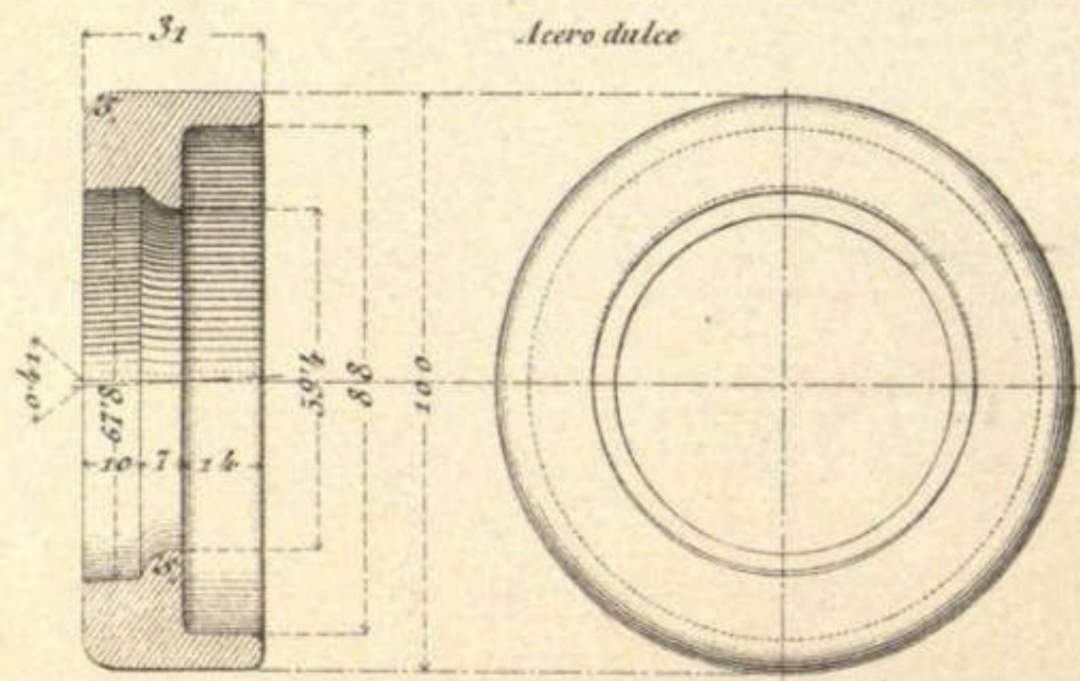

2 Arandelas de eje exteriores

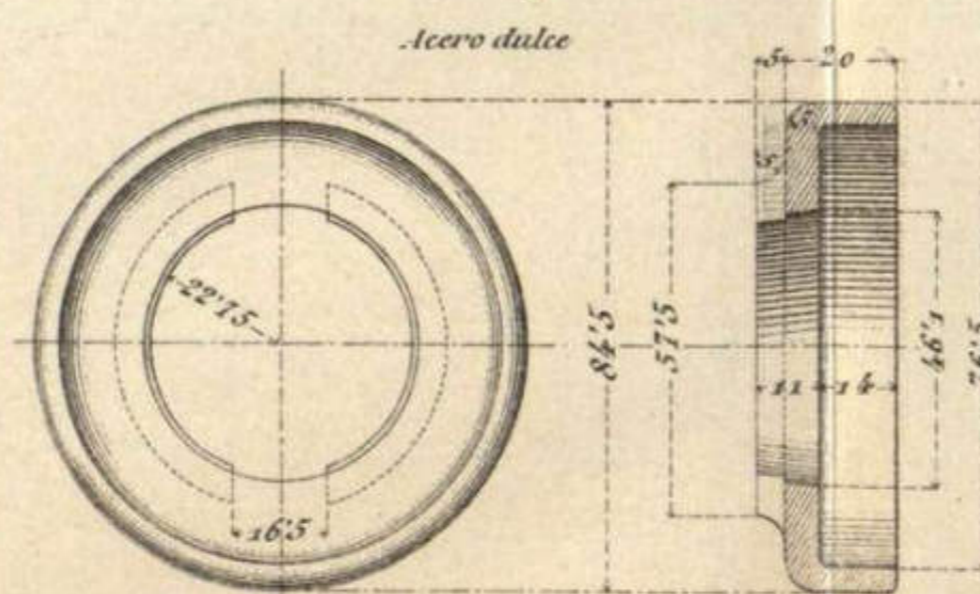

2 Chavetas

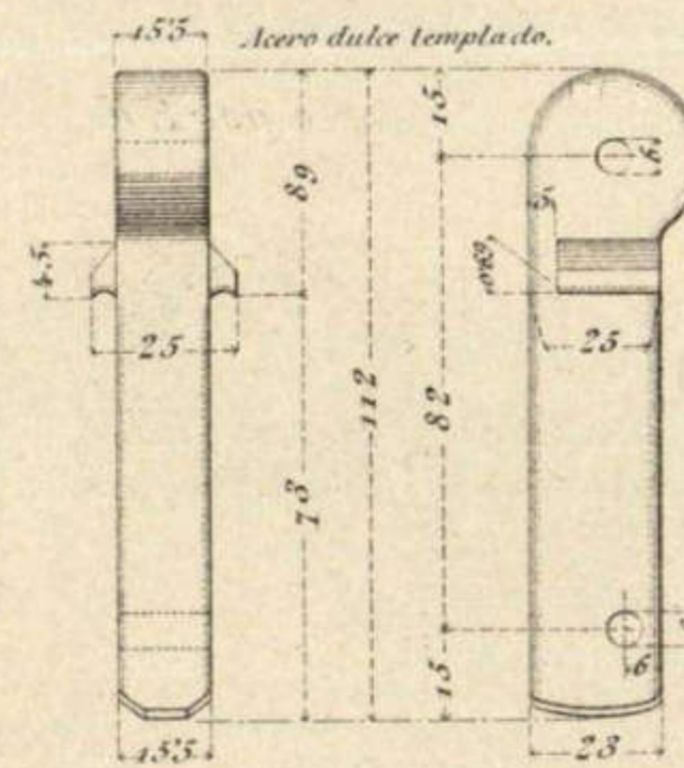

2 Anillas

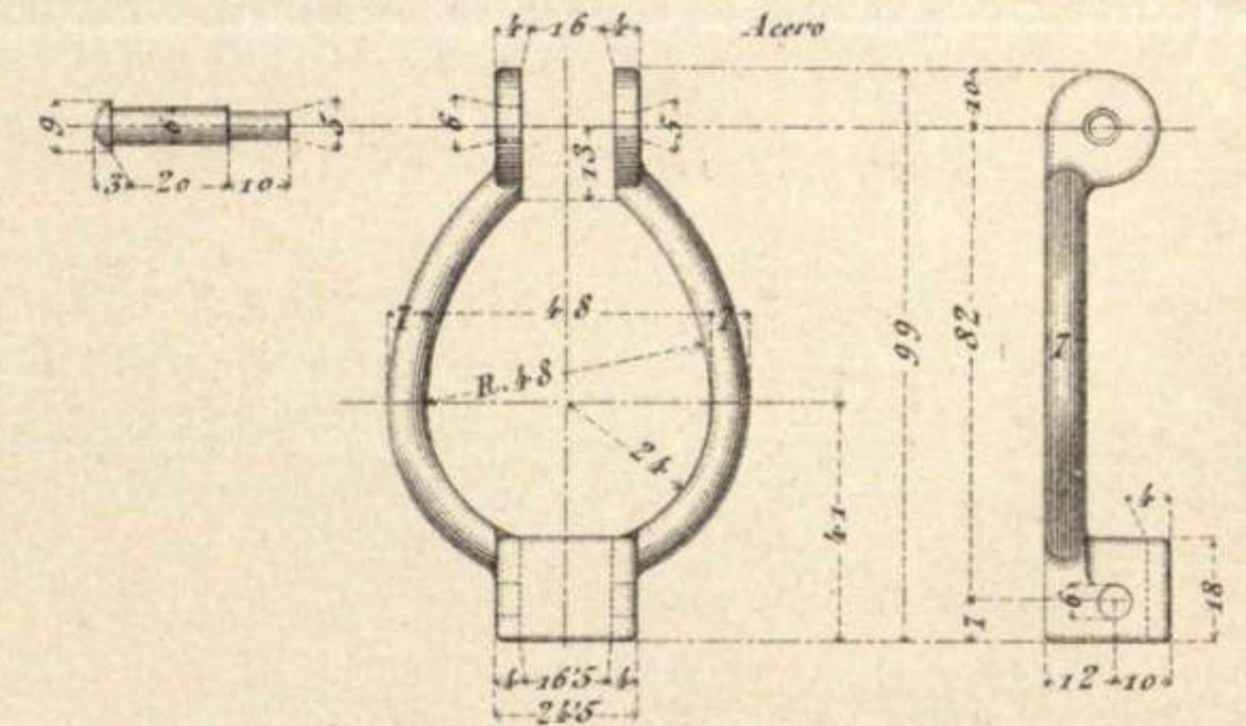

2 Rodajas

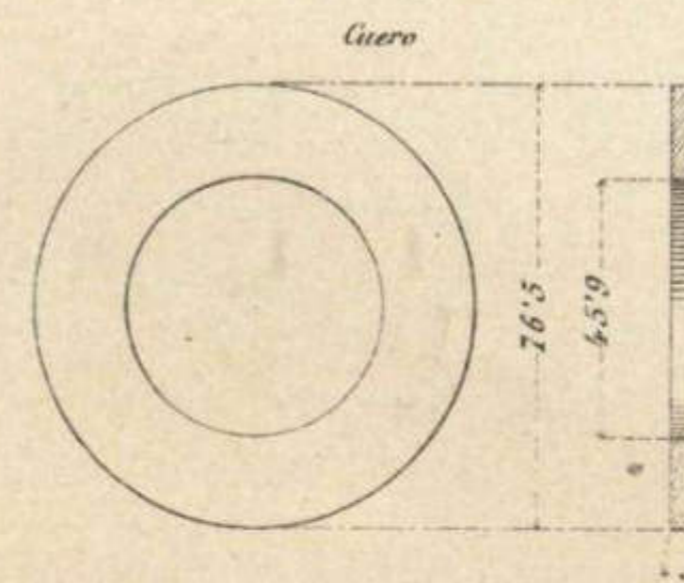

2 Rodajas

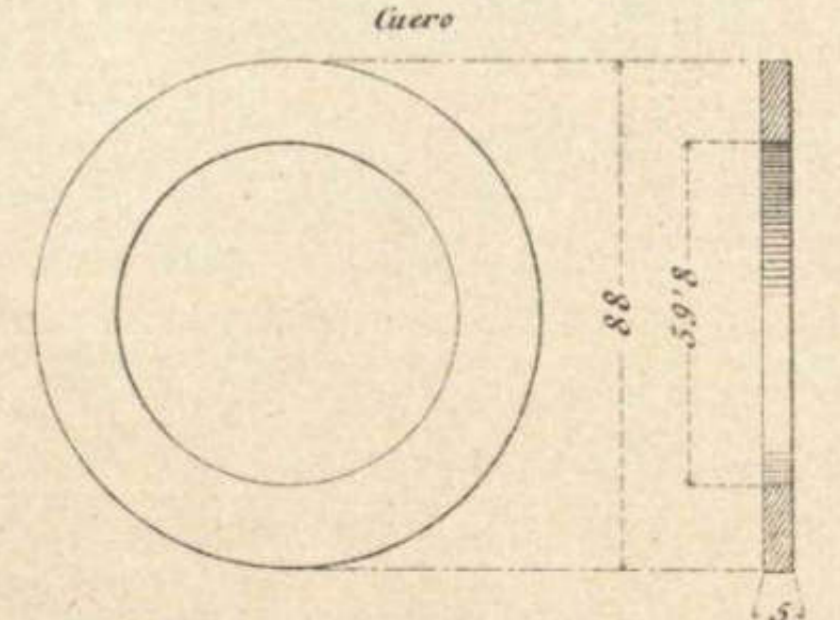

ARMON PARA MATERIAL KRUPP Y SAINT CHAMOND.

DETALLES.

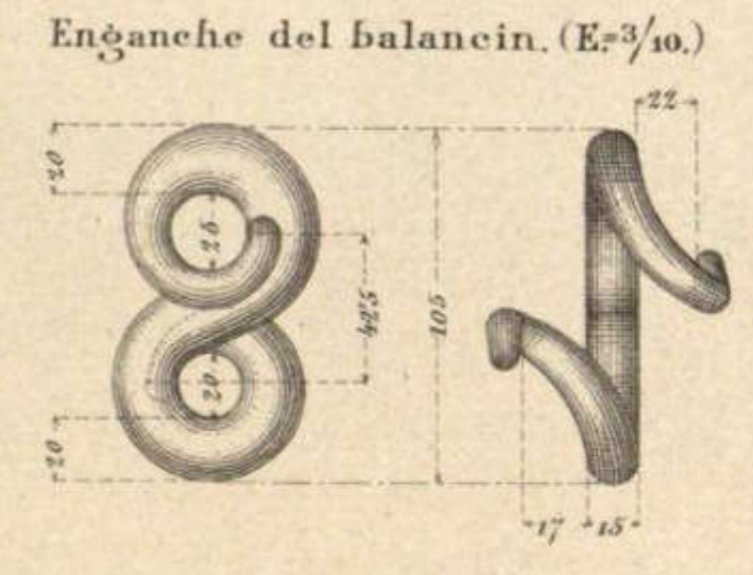
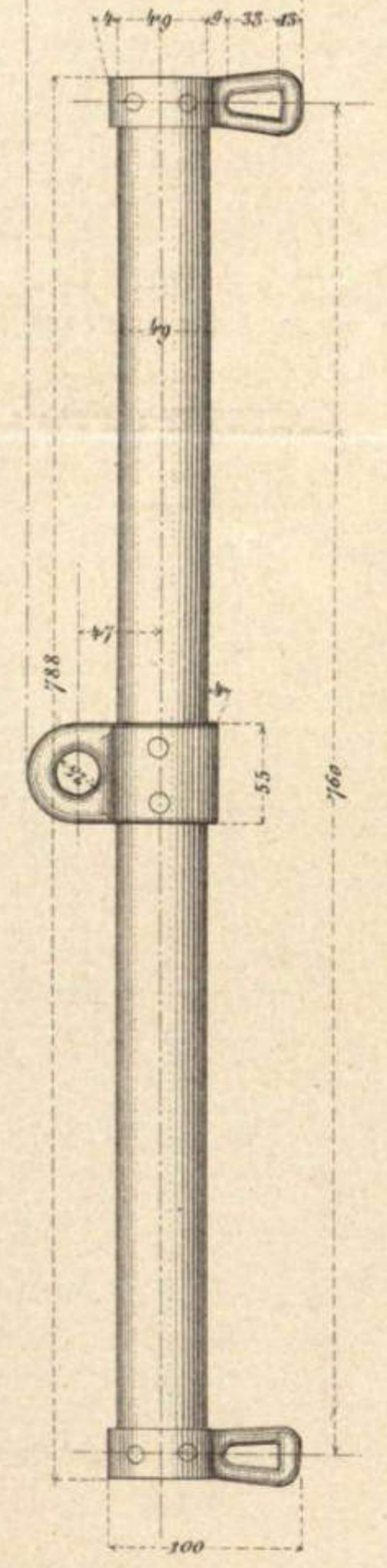
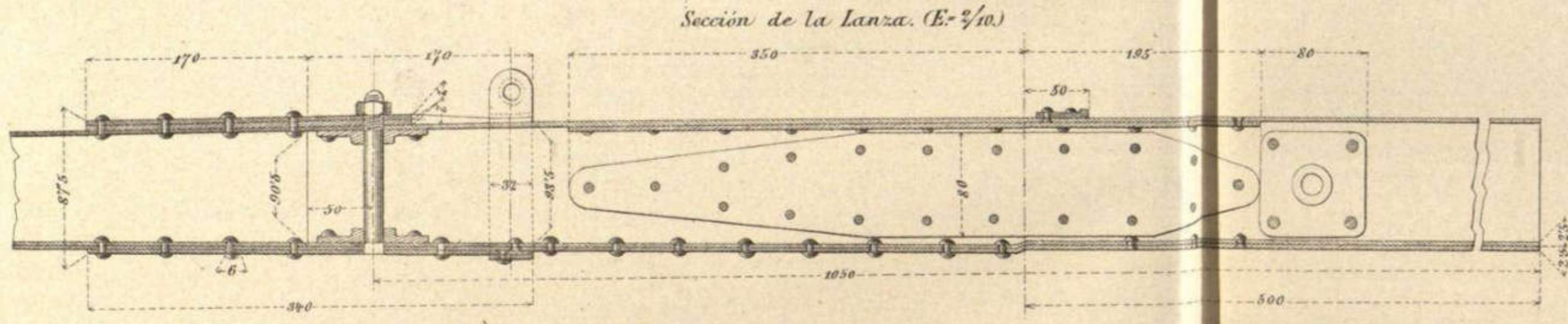
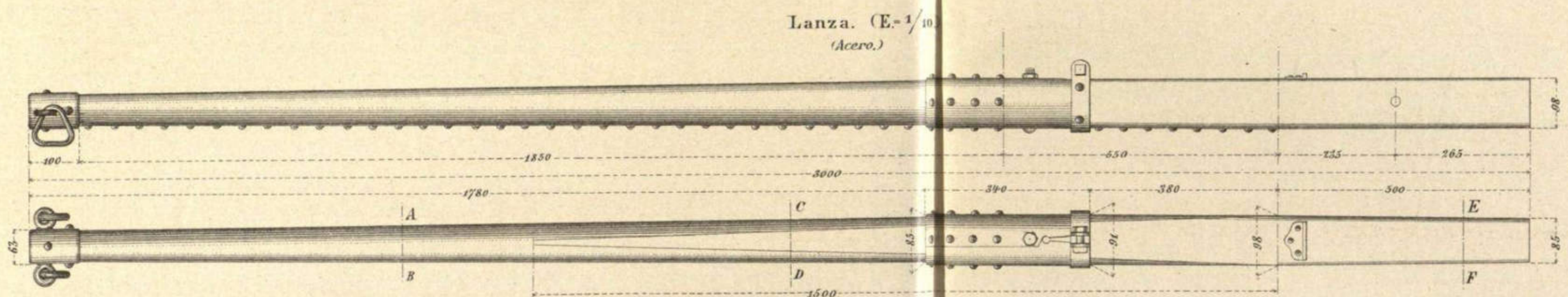
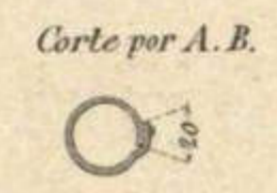
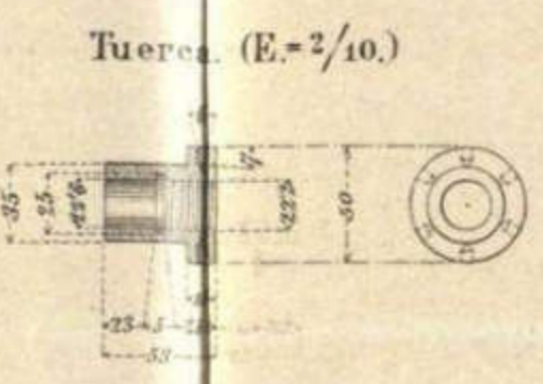
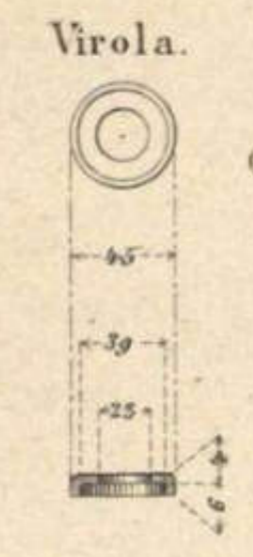
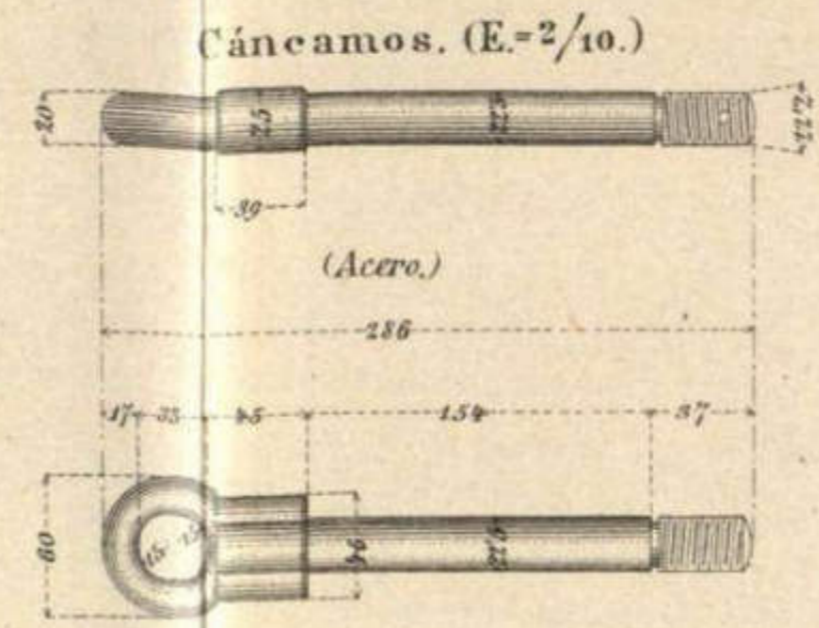
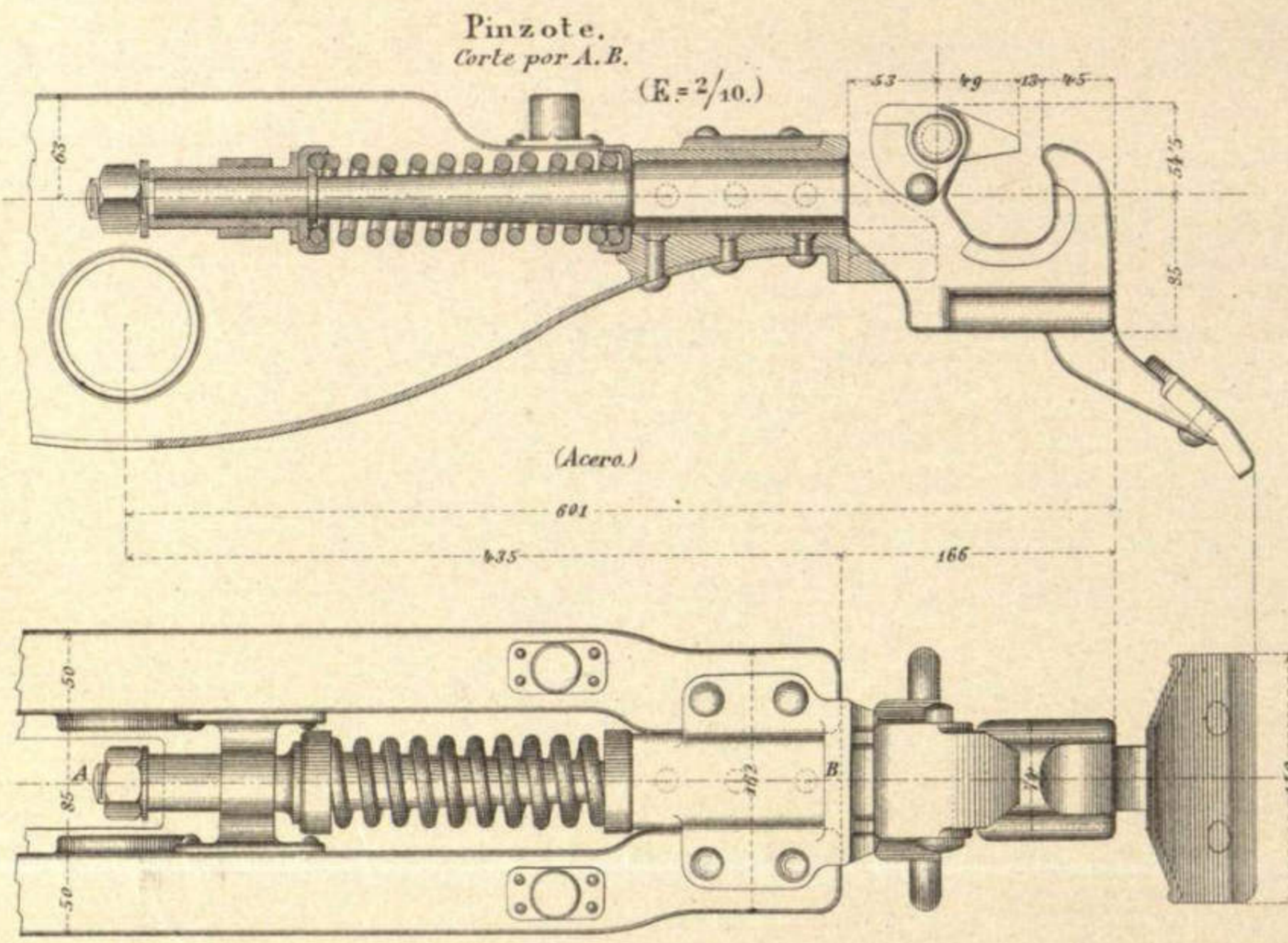

CARRO PARA MATERIAL KRUPP Y SAINT CHAMOND.

VISTA VERTICAL

Escala 1/10

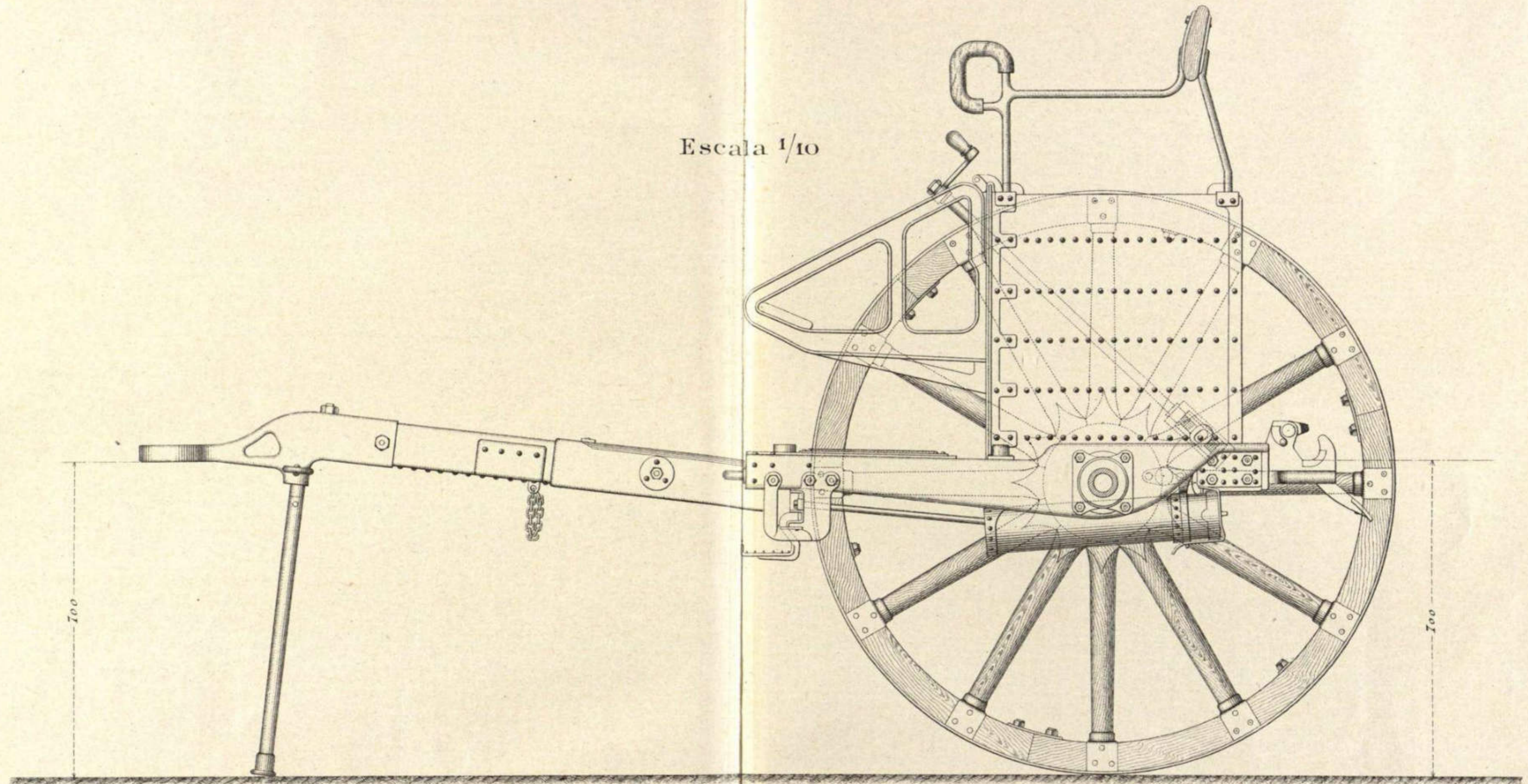

CARRO PARA MATERIAL KRUPP Y SAINT CHAMOND.

VISTA HORIZONTAL

Escala 1/10

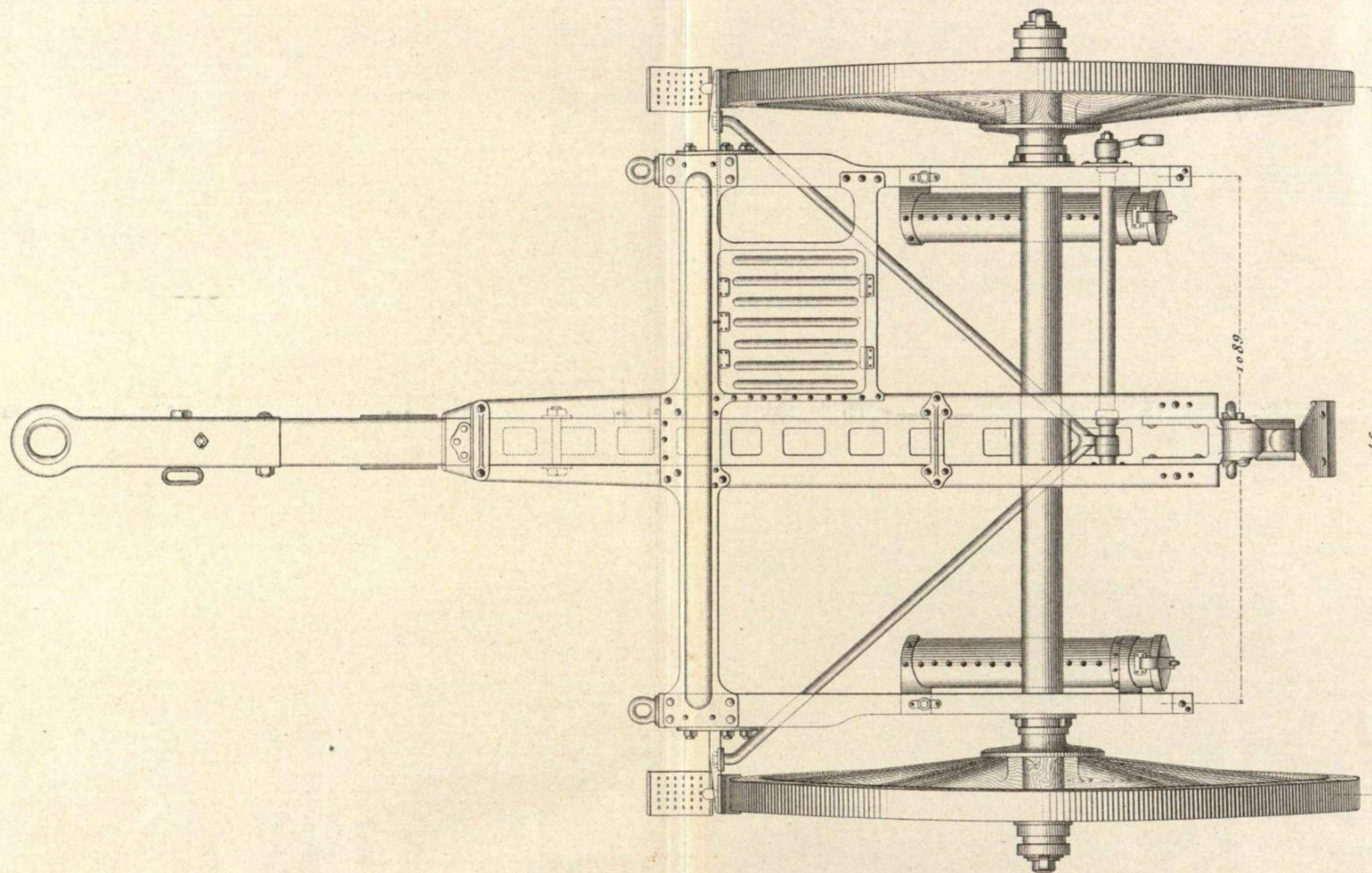

CARRO PARA MATERIAL KRUPP Y SAINT CHAMOND.

DETALLES.

Escala 5/10.

Eje.

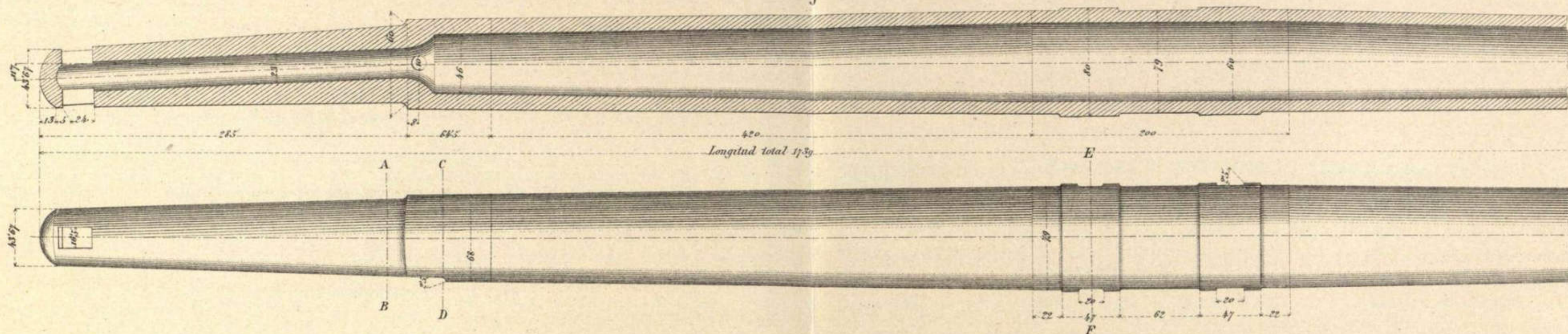

Pinzote.

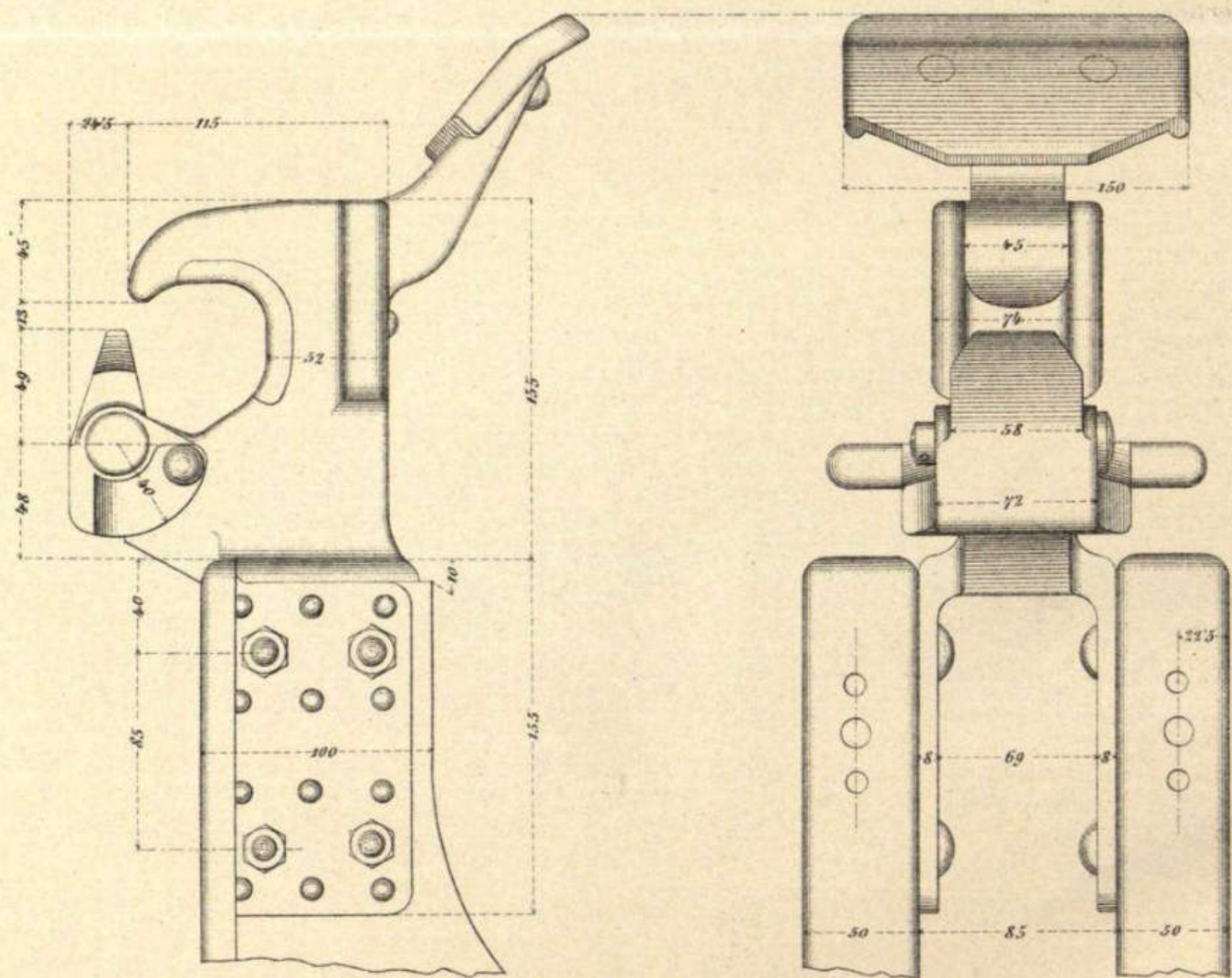

Corte por A.B.

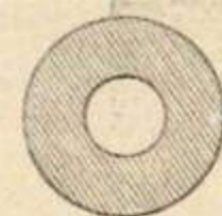

Corte por C.D.

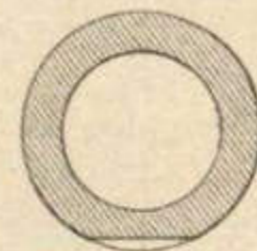

Corte por E.F.

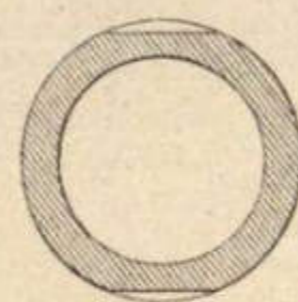

Cáncamo.

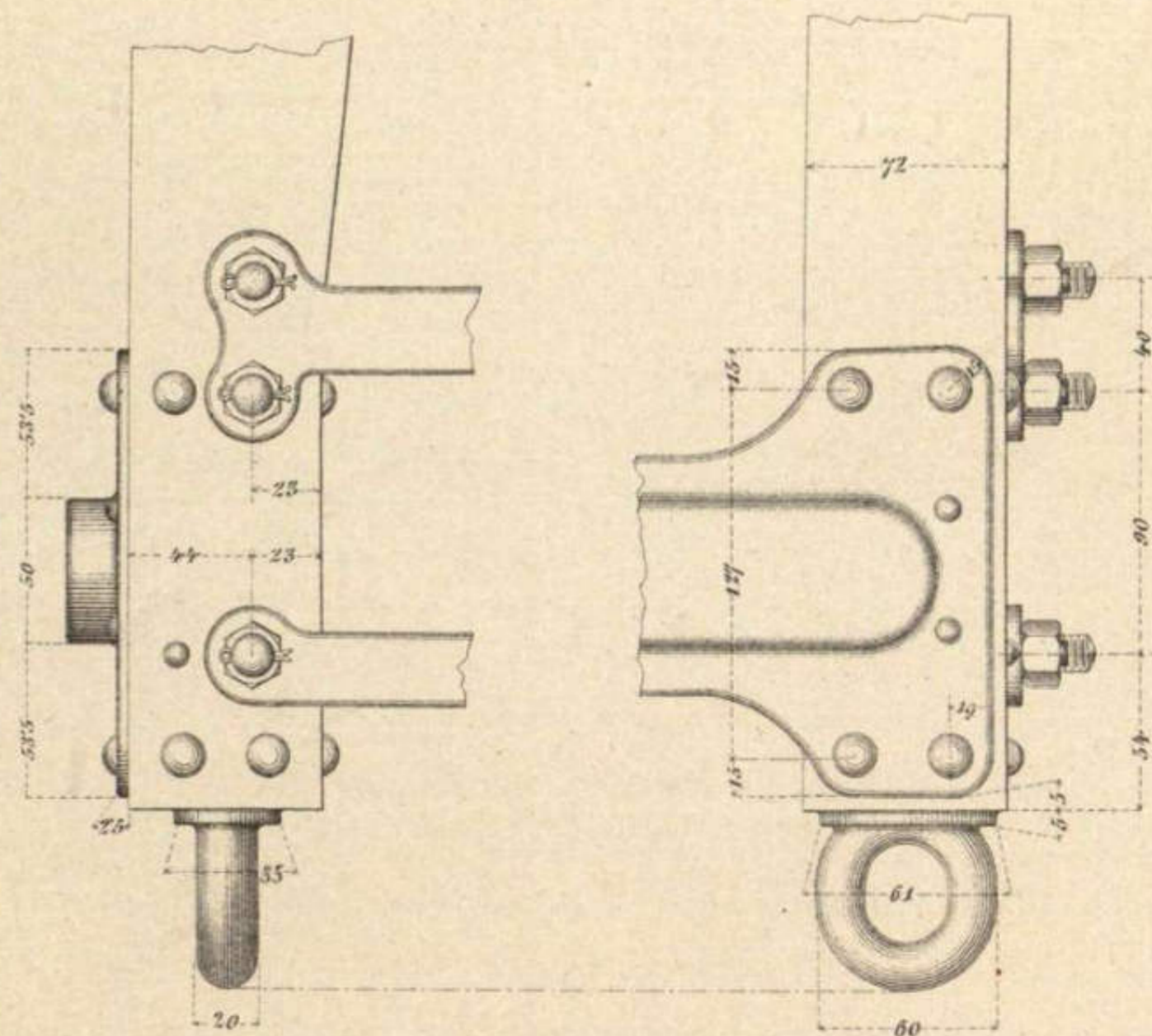

ARMON PARA MATERIAL KRUPP Y S^t CHAMOND

DETALLES

Escala 2/10

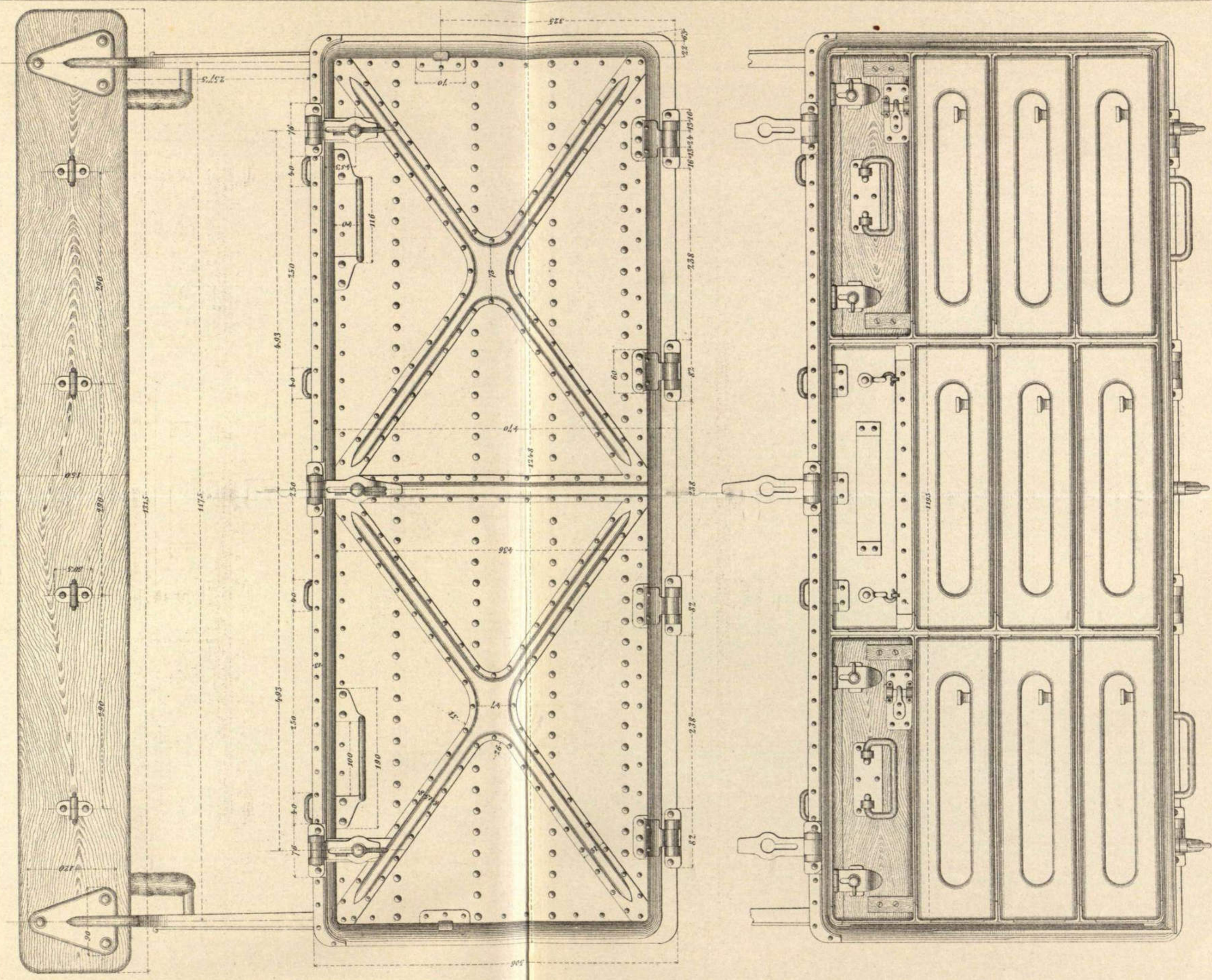

CAÑON T. r. DE 7'5 cm. DE CAMPAÑA KRUPP

ALZA Y PUNTO DE MIRA.

(Escala 7/10)

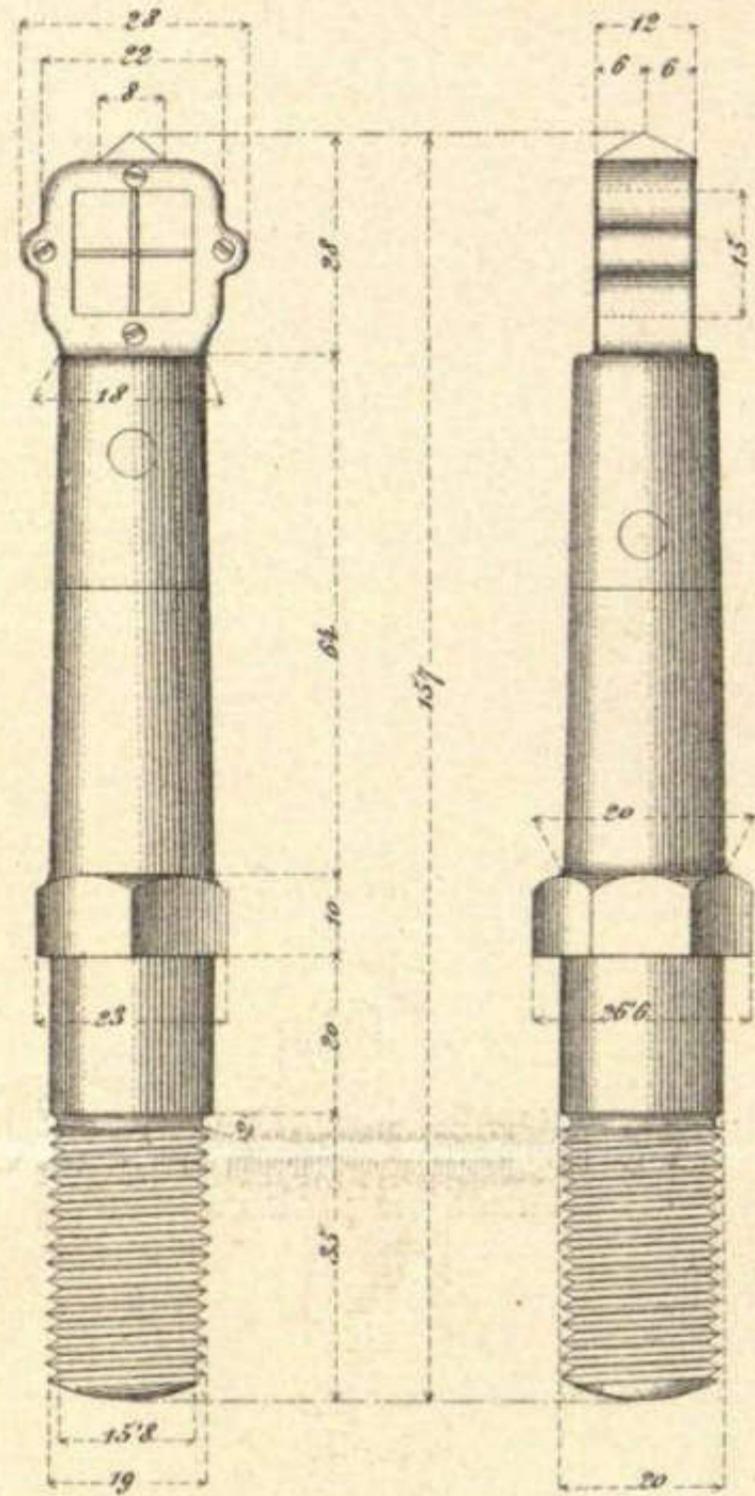

Escala 5/10.

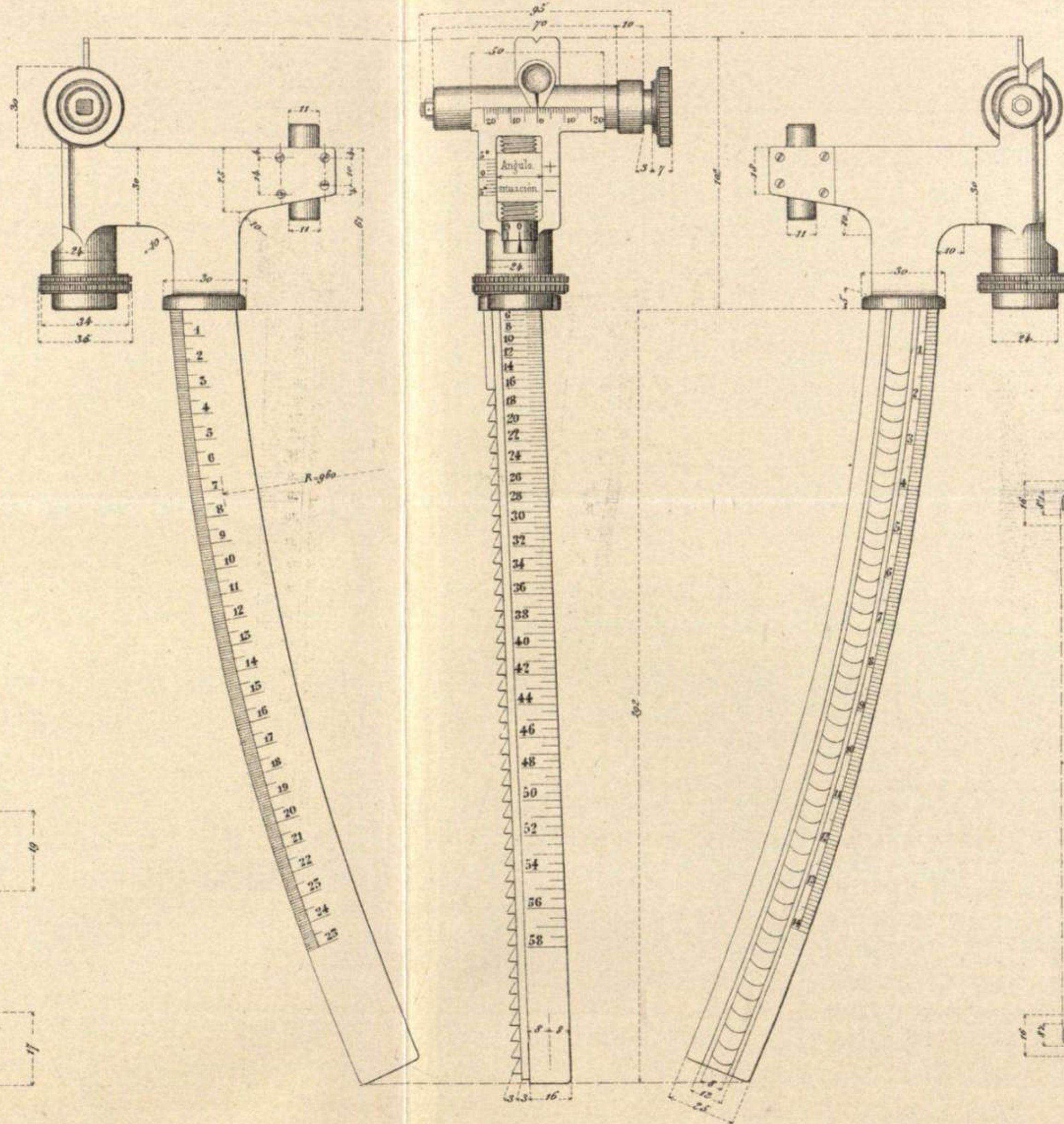

(Escala 7/10).

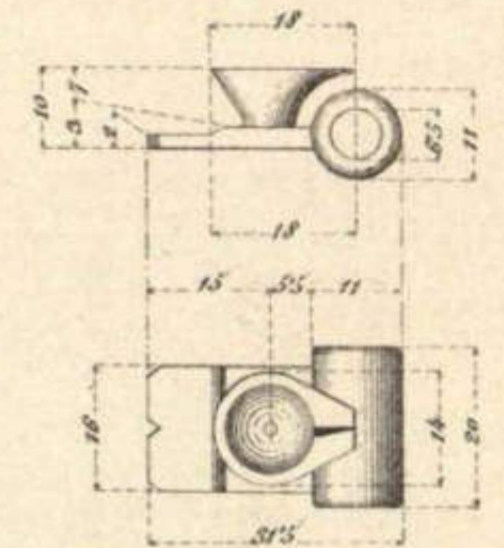

(Escala 5/10)

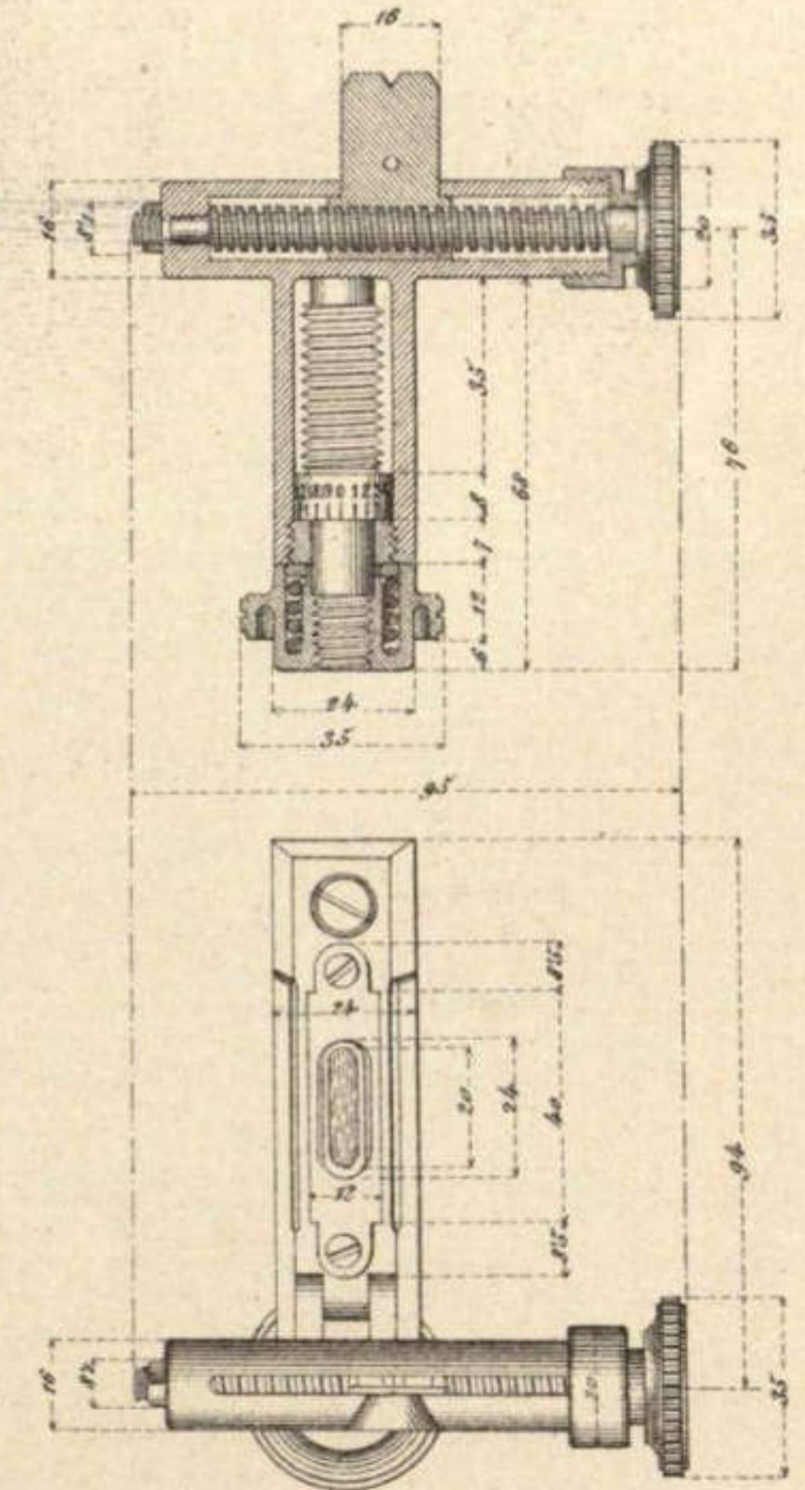

(Escala 8/10)

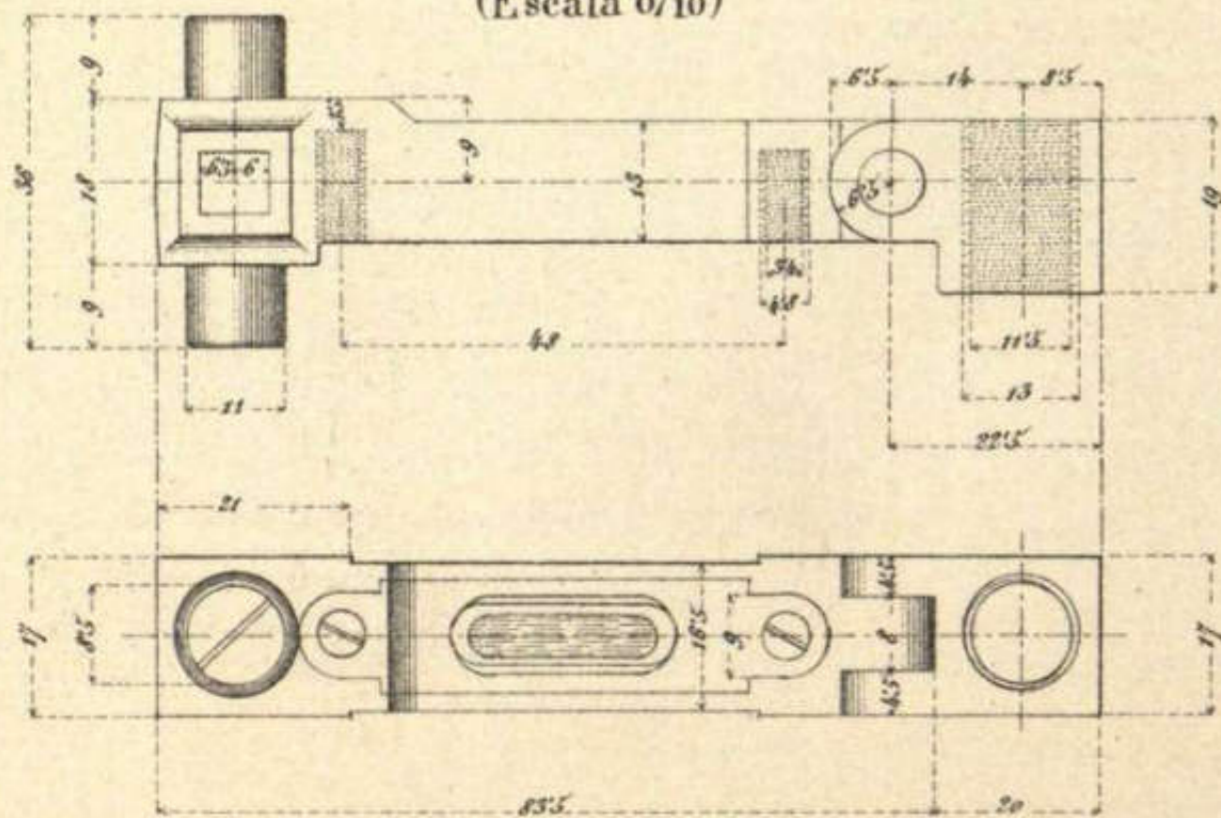

PROYECTILES PARA LOS CAÑONES DE T. r. DE 7'5 cm. DE CAMPAÑA

Escala 5/10

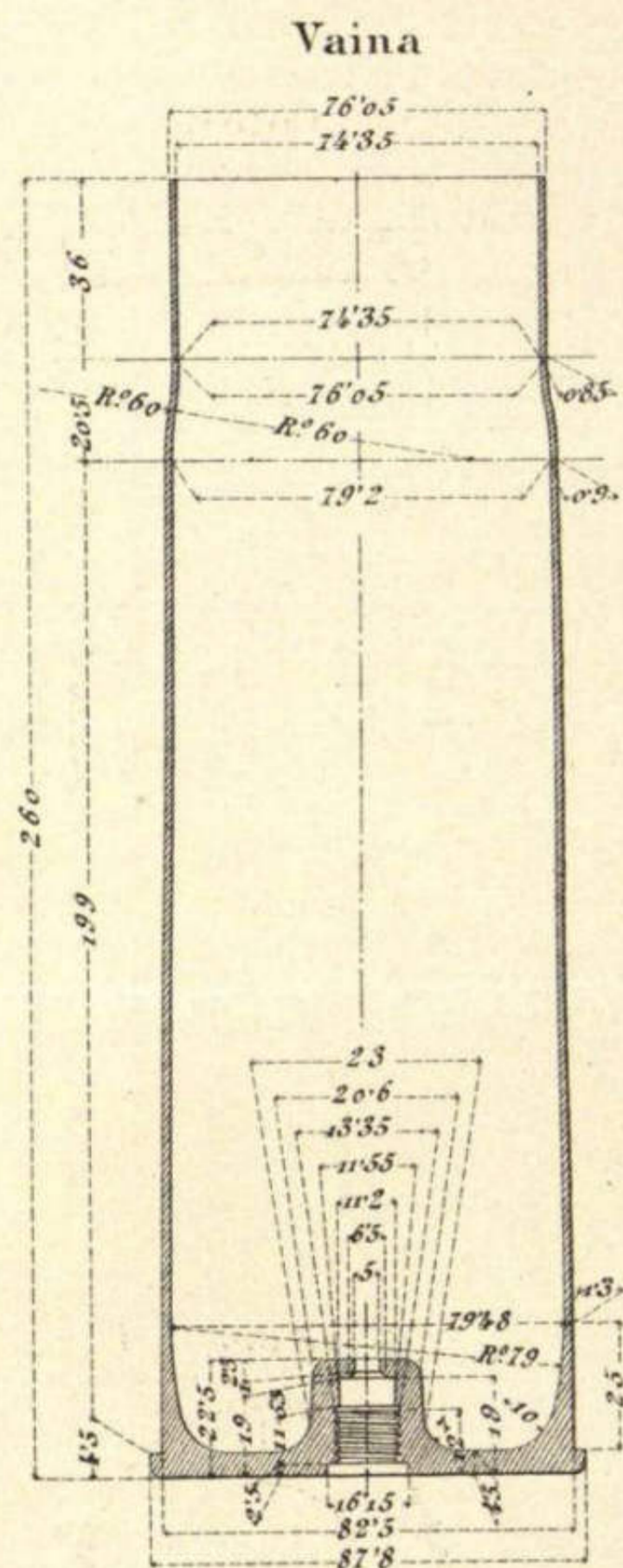

Granada ordinaria.

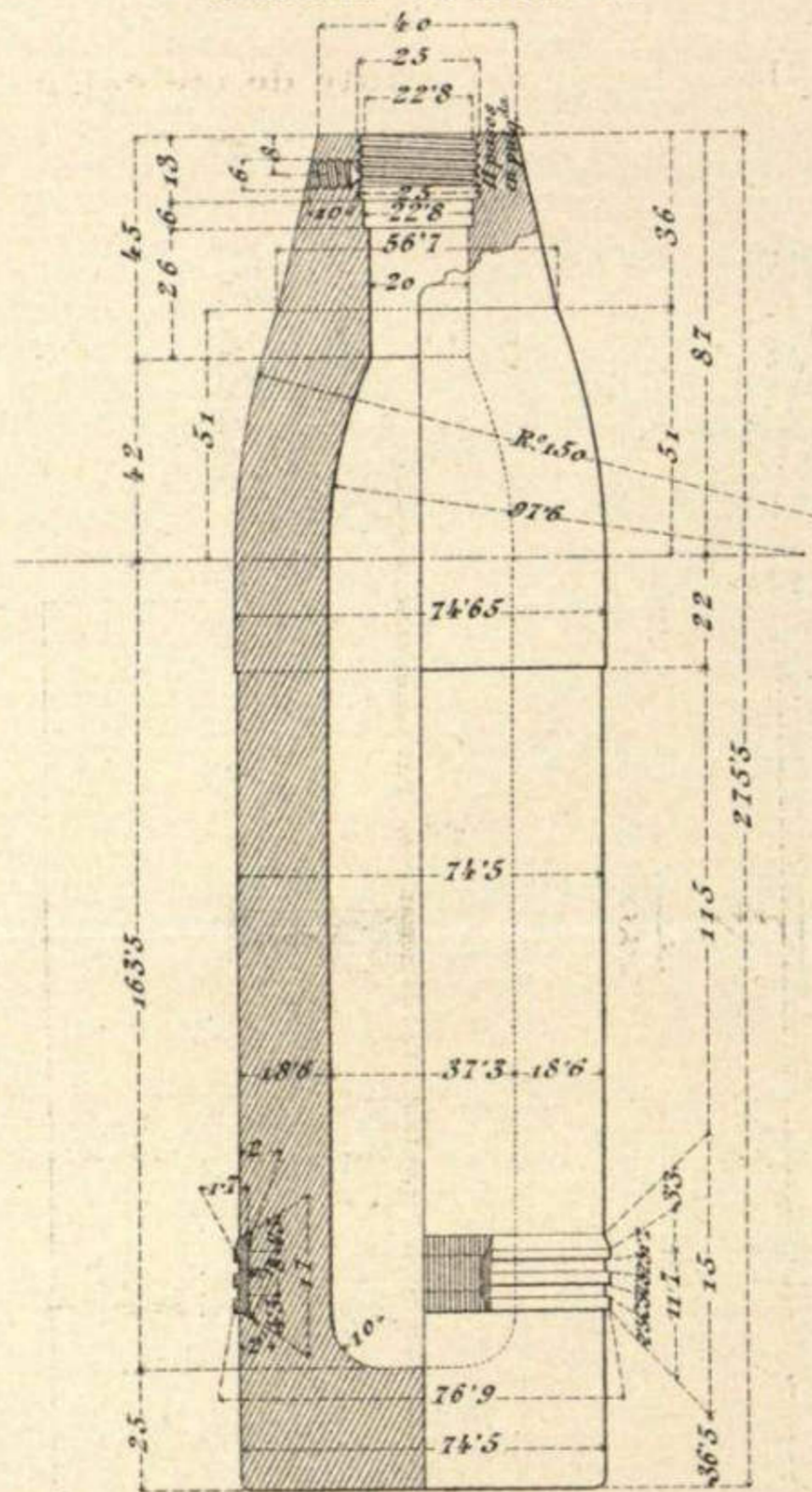

Granada de metralla.

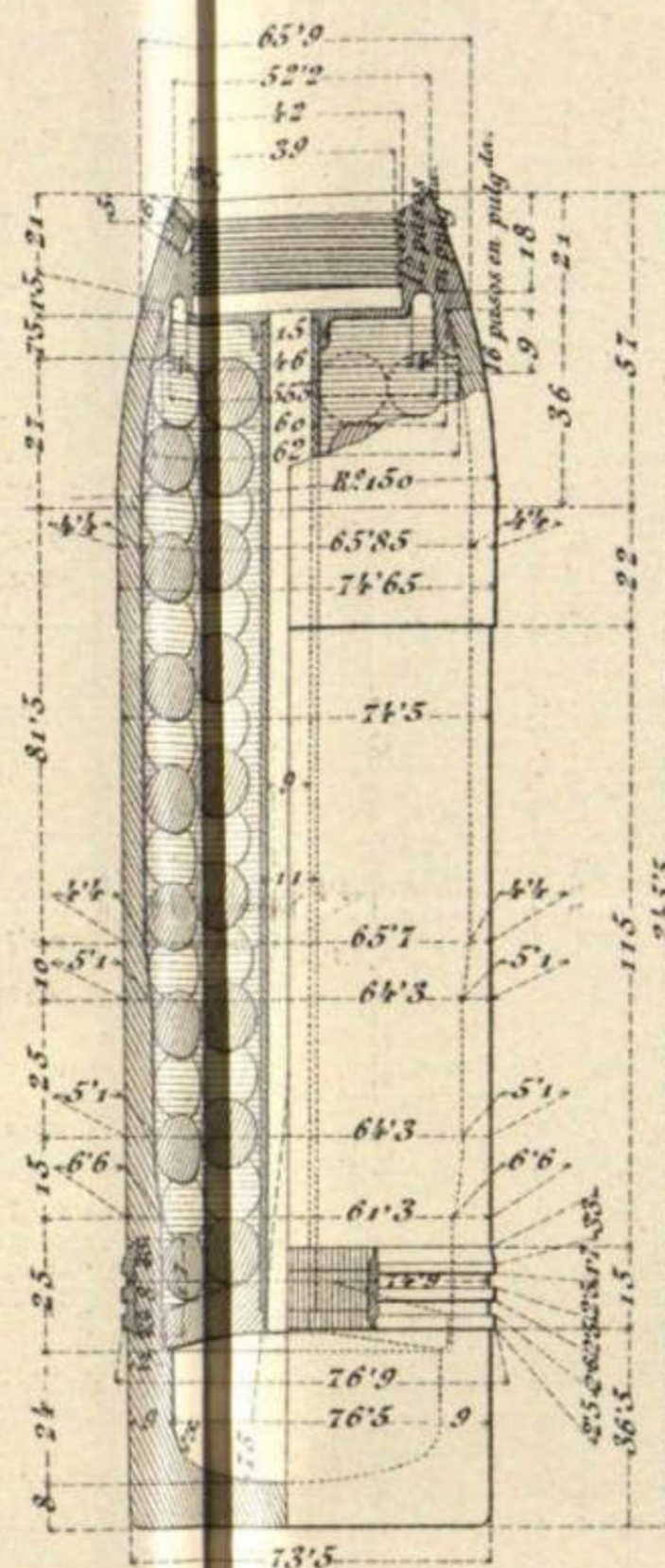

Bote de metralla.

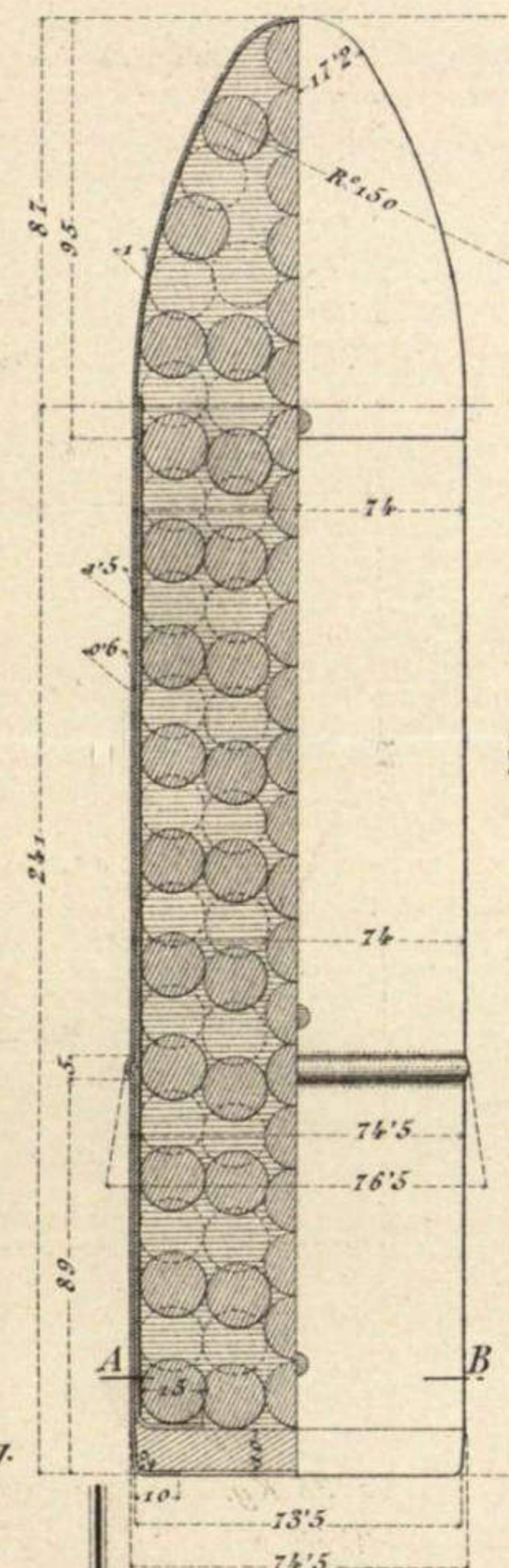

Culote

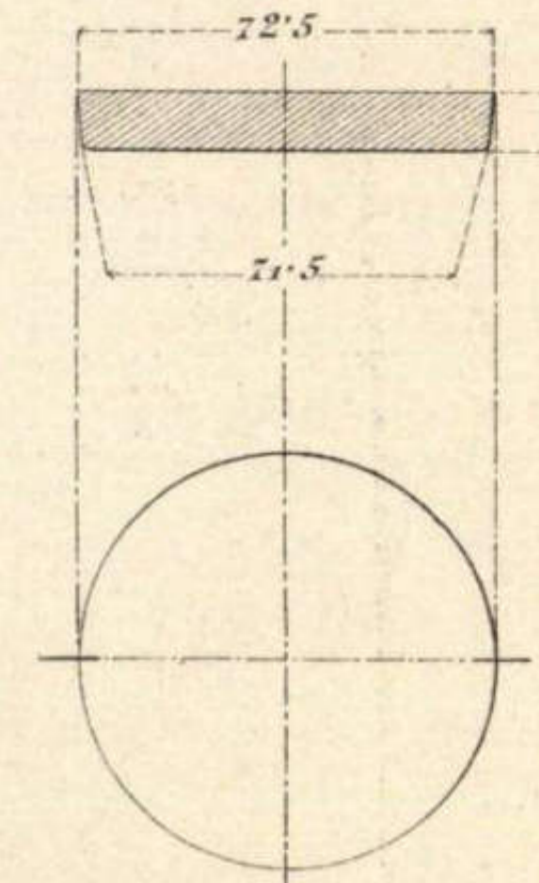

Corte por A.B.

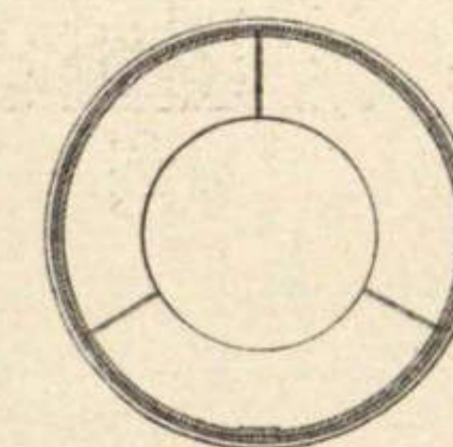

Peso de la granada ordinaria vacía..... 6,135 Kg.
 Id. de la carga explosiva..... 0,240 "
 Id. de la espoleta de percusión..... 0,125 "
 Peso total de la granada cargada..... 6,500 "

Peso de la granada de metralla vacía..... 2,800 Kg.
 Id. de la granada cargada..... 5,965 "
 Id. de la carga explosiva..... 0,075 "
 Id. de la espoleta de doble efecto..... 0,460 "
 Id. de la granada cargada con espoleta..... 6,500 "
 Número de balines..... 250
 Peso de cada balín..... 0,011 "
 Los balines van sujetos con colgancia.

Peso del bote de metralla..... 8,750 Kg.
 Número de balines..... 410
 Peso de cada balín..... 0,016 "

GRANADA ROMPEDORA PARA C. T. R. DE 7'5 CM.

Escala 1/4

Granada cargada y cebada con detonador fulminante.

Granada vacia de acero.

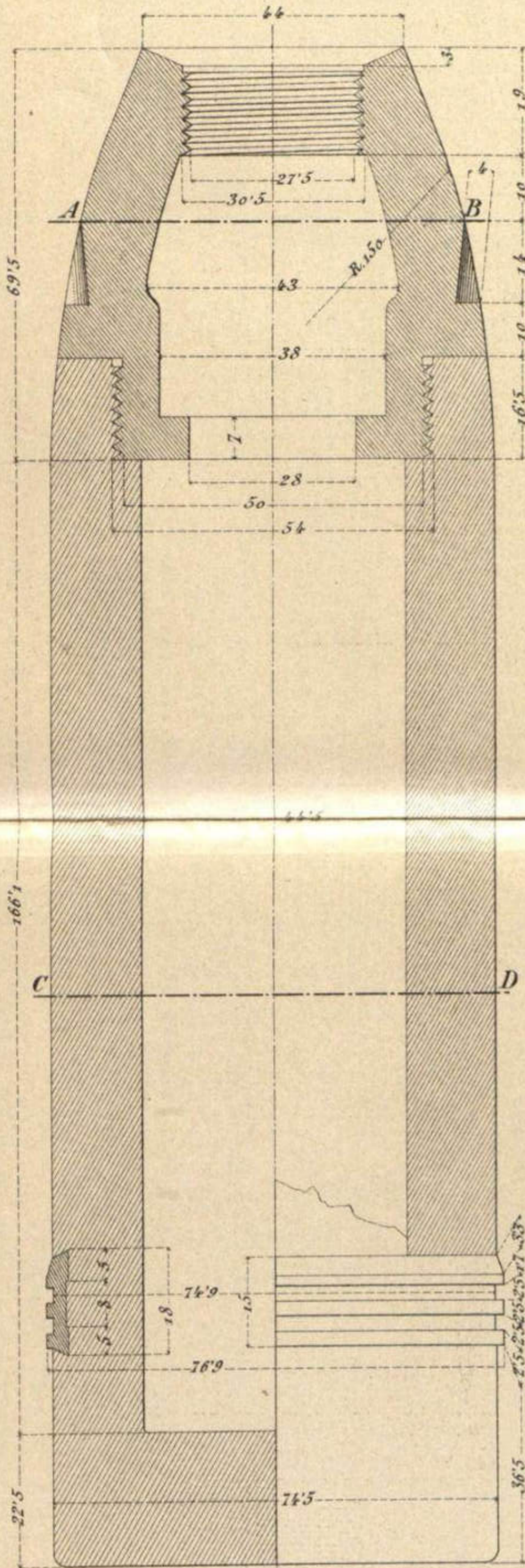

Corte por A.B.

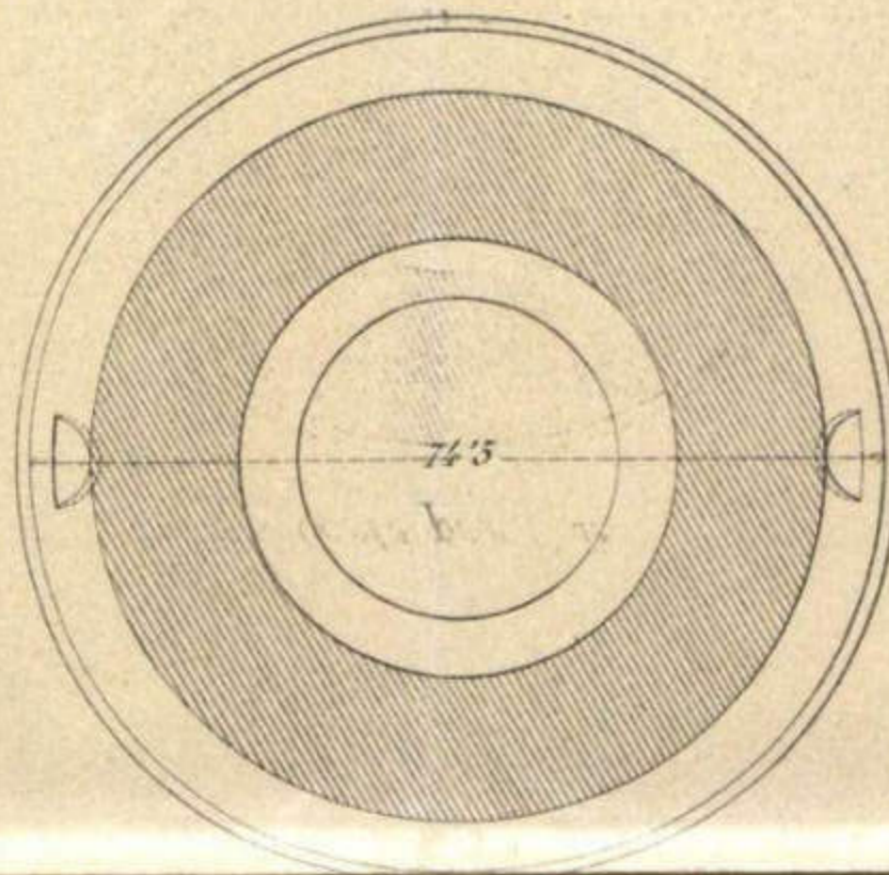

Corte por C.D.

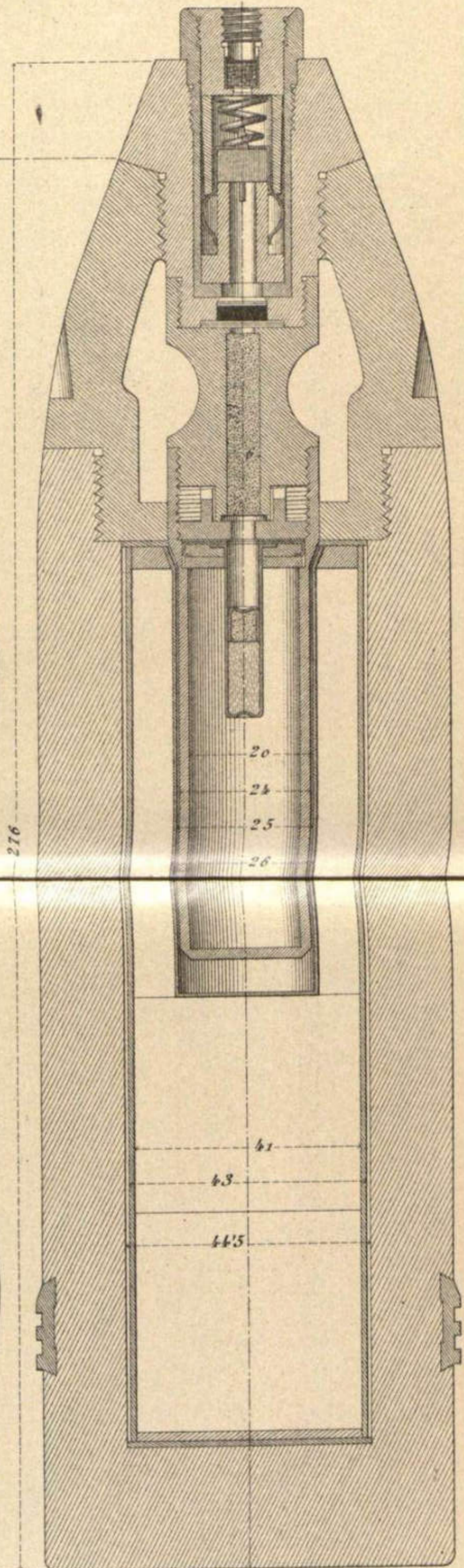
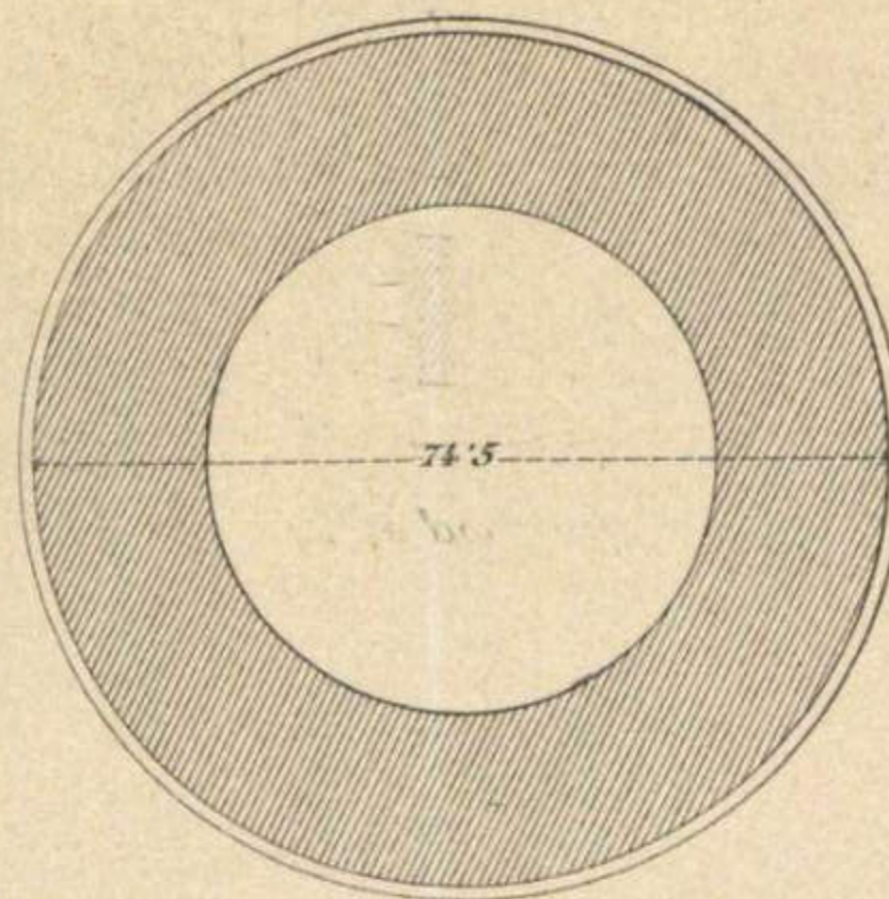

Peso de los elementos que constituyen el proyectil.

| | |
|--------------------------|------------|
| Cuerpo cilindrico | 4736 |
| Cuerpo ojival incompleto | 0.946 5688 |

Peso de los elementos del detonador.

| | |
|-----------------------------------------------|------------------|
| Espoleta cargada | 0.084 |
| Petardo | 0.083 |
| Suplemento | 0.193 |
| Vaina del multiplicador | 0.107 |
| Tapon roscado para la vaina del multiplicador | 0.012.255 |
| Cebo armado completo sin carga | 0.003.195482.450 |

Peso de las cargas.

| | |
|-----------------------------------------------|--------------------|
| Carga explosiva de Trilita | 0.270 |
| Envuelta de carton para la carga | 0.030 |
| Carga de trilita para el multiplicador | 0.029.200 |
| Carga de la capsula del cebo | 0.000.360 |
| Carga de trilita para la vaina del cebo | 0.000.500 |
| Carga de la canal de comunicacion del petardo | 0.001.100 |
| Balleta de comunicacion del suplemento | 0.000.250 |
| Peso de los discos, rodajas, etc. | 0.004.140 0335.550 |
| Total | 6500.000 |

ESPOLETA DE PERCUSION MODELO 1896. MODIFICADA POR REAL ORDEN CIRCULAR 31 OCTUBRE 1906.

Escala natural.

En disposición de tiro.

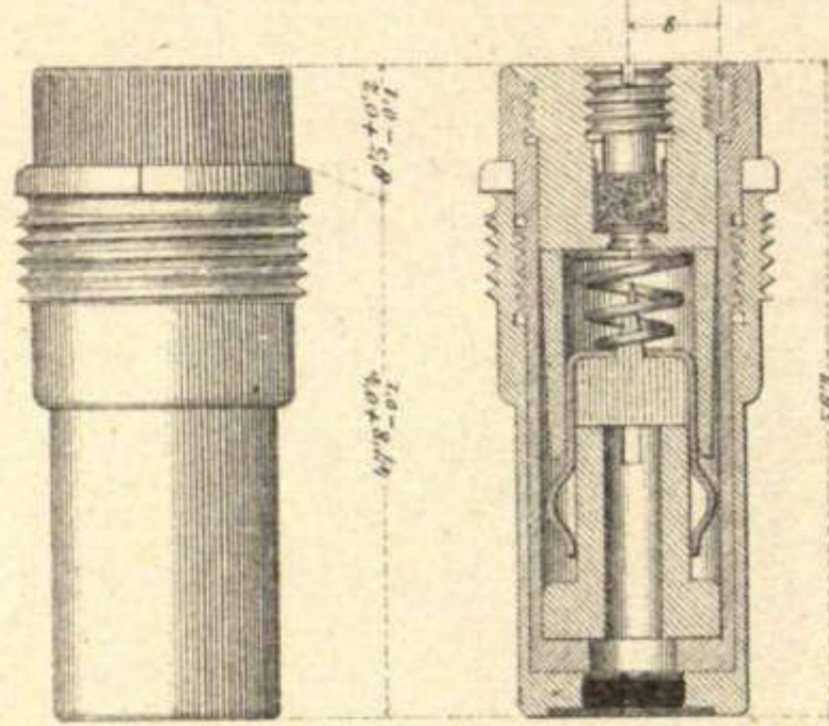

En disposición de transporte.

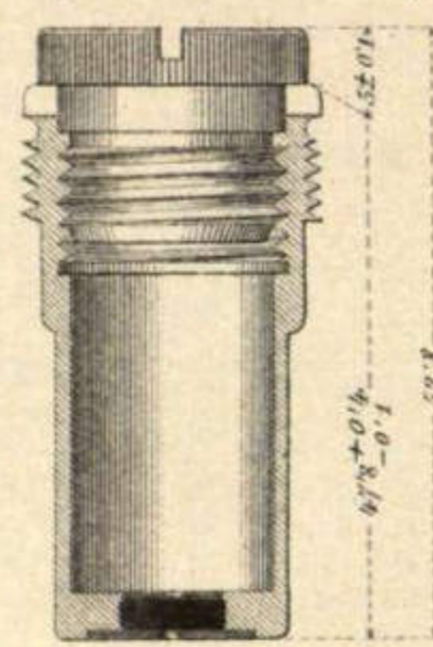

Suplemento de espoleta.

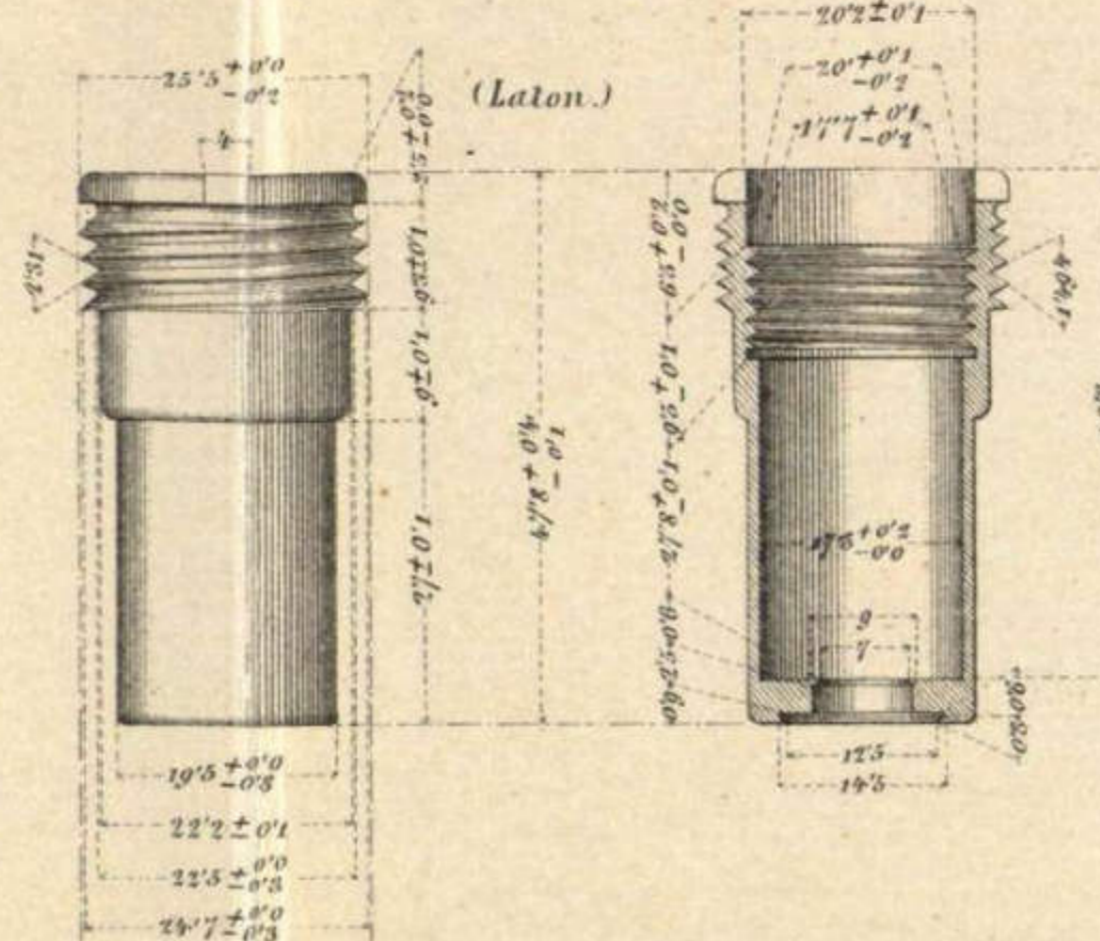

Cuerpo de espoleta.

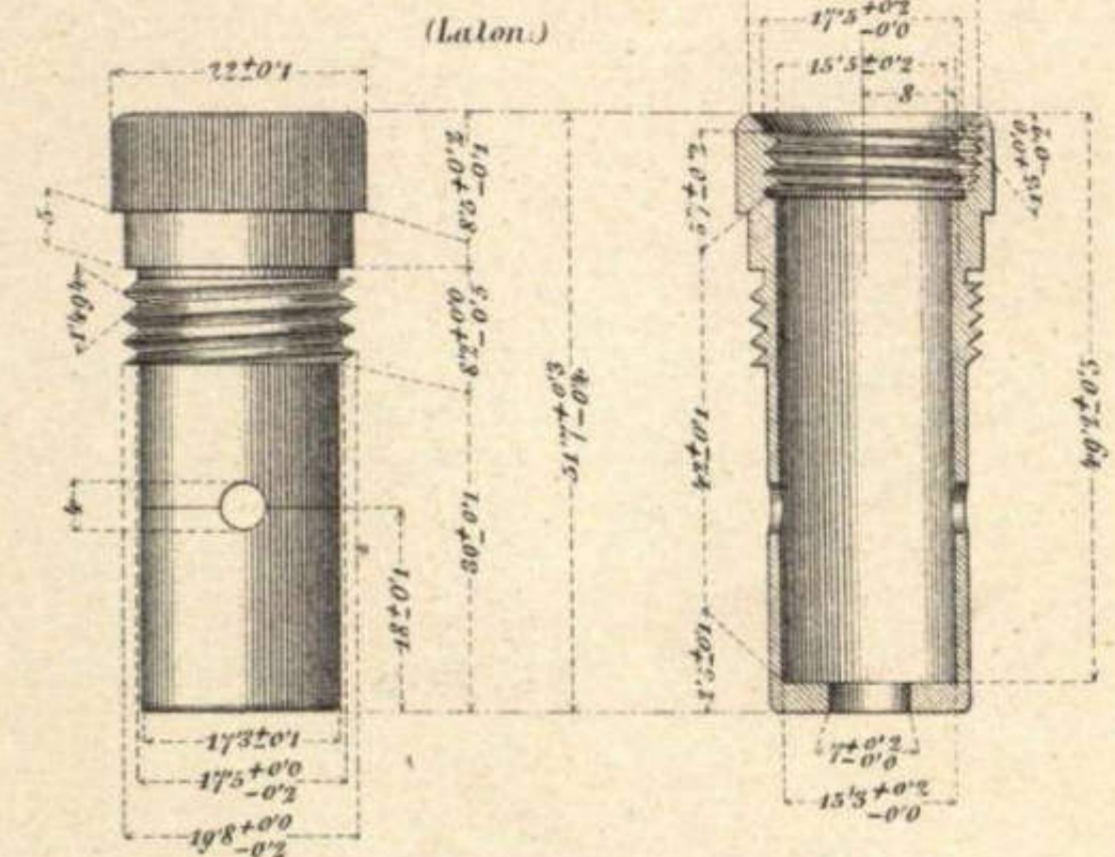

Tapon de transportes

(Zinc.)

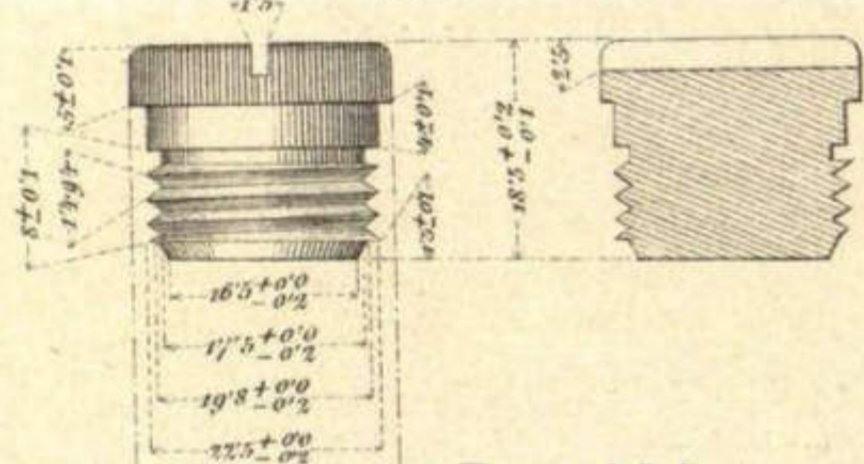

Porta-cebo.

(Latón.)

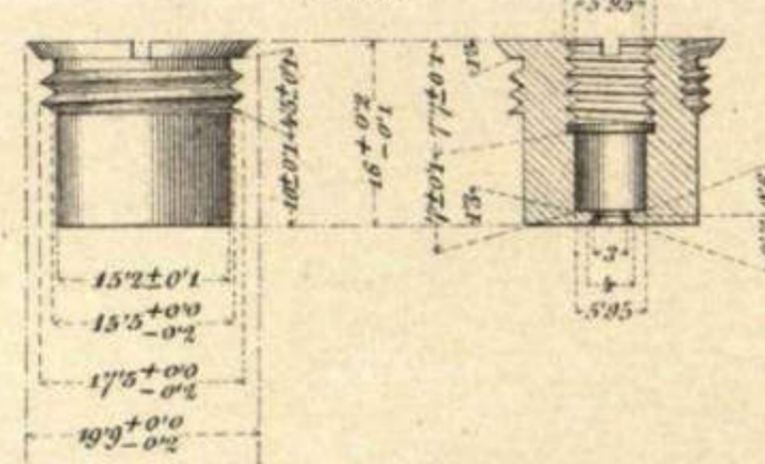

Tornillo que constituye

la modificación.



Aguja de acero.

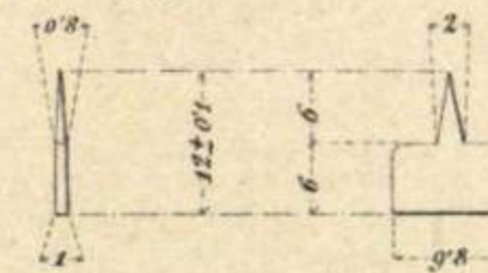

Muelle espiral.

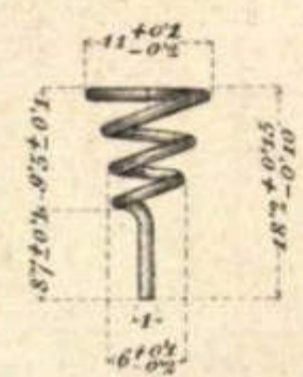

Tapon del Porta-cebo.

(Latón.)

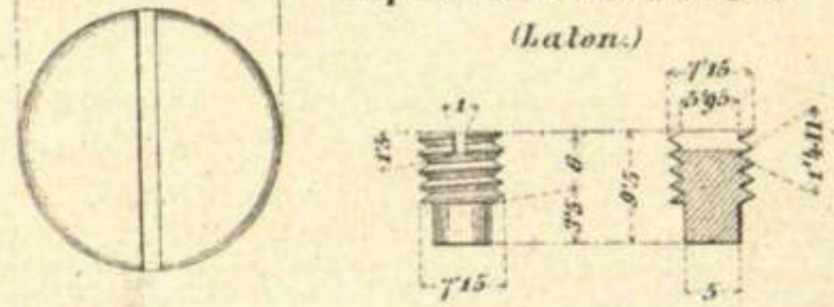

Contra-percutor.

(Latón.)

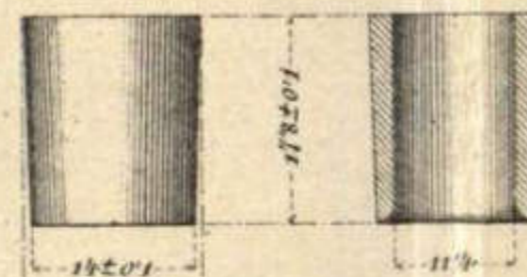

Percutor.

(Latón nikelado.)

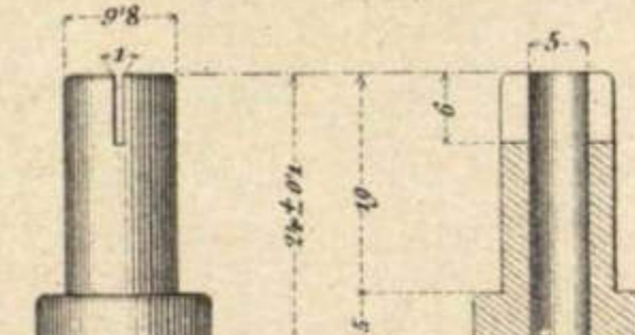

Muelle de Pachffond.

Embulido.

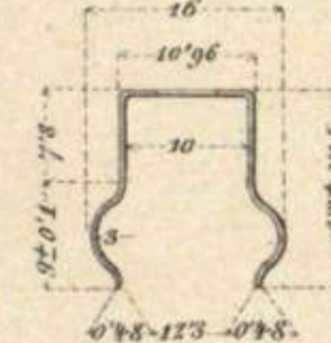

Cápsula.

(Cobre)

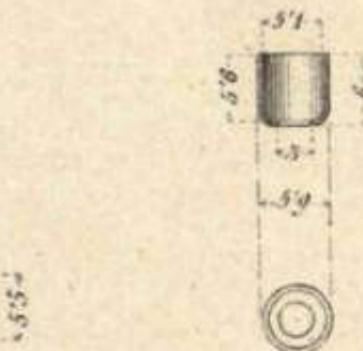

Discos de latón para la cápsula.

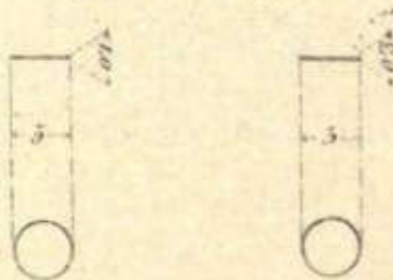

Disco de latón

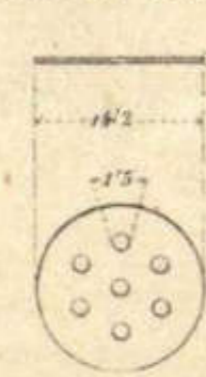

Disco de tela.

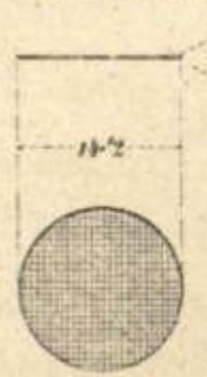

Galleta de pólvora.

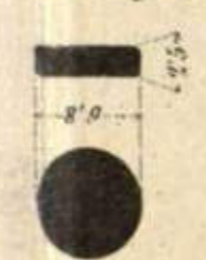

Disco de tela.



Disco de cobre



ESPOLETA DE DOBLE EFECTO MODELO 1907. DETALLES.

En disposicion de tiro.

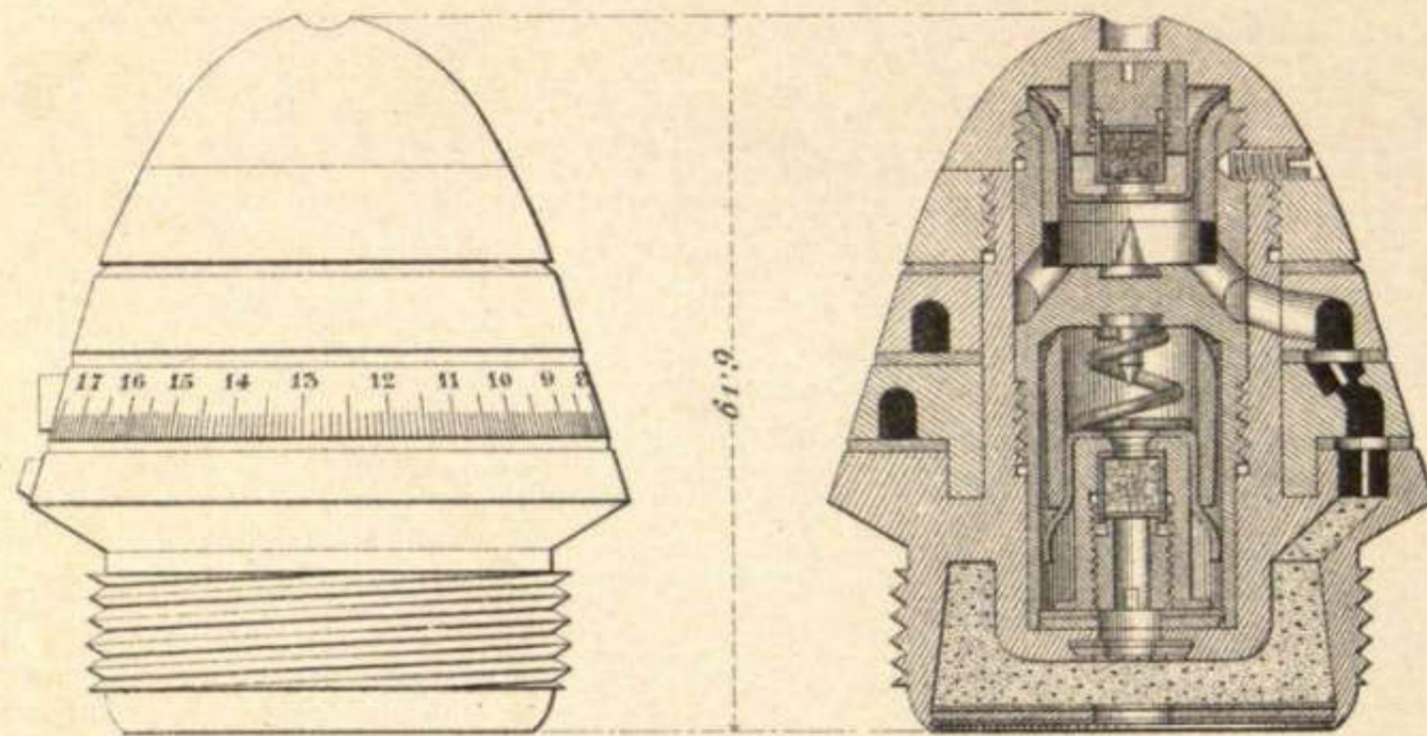

Porta-percutores

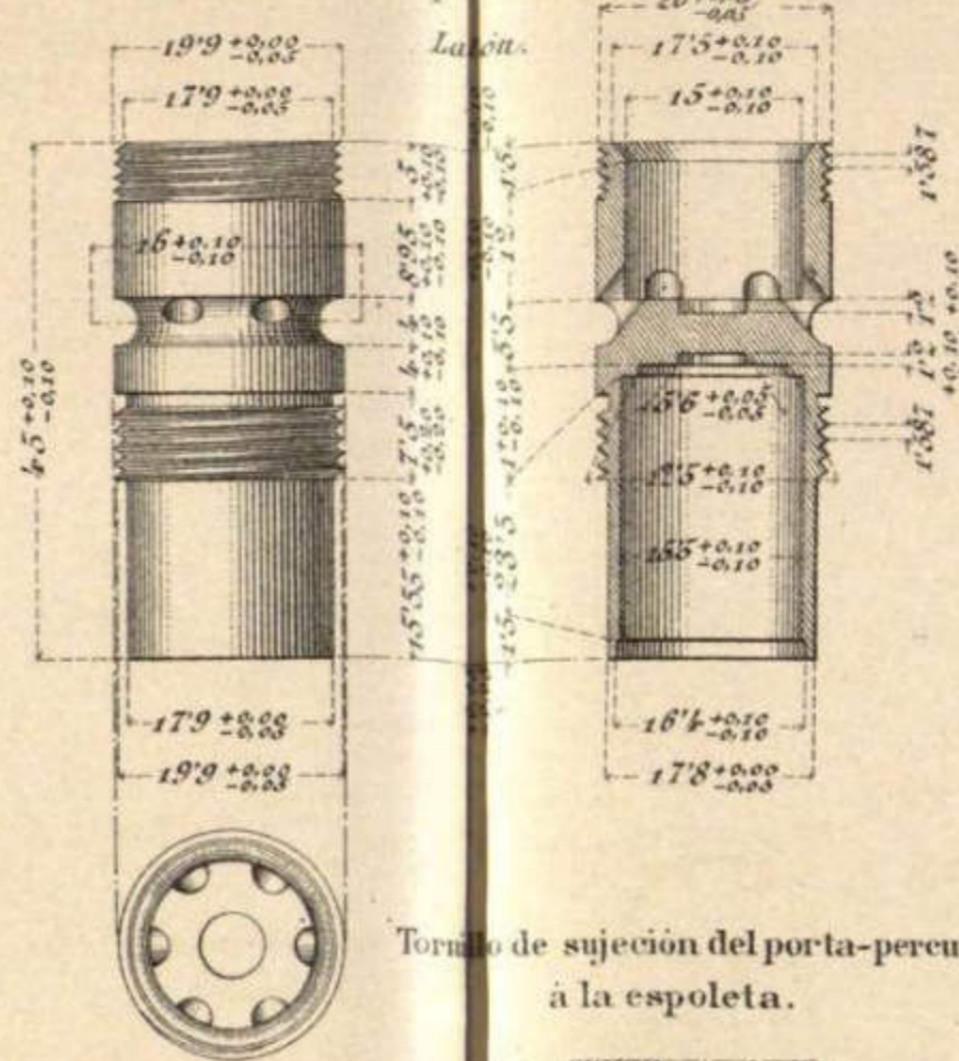

Tornillo de sujecion del porta-percutores a la espoleta.

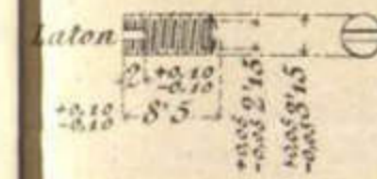

Cabeza del porta-percutores.



Teton de acero. Rosca izquierda.



Cabeza de apriete

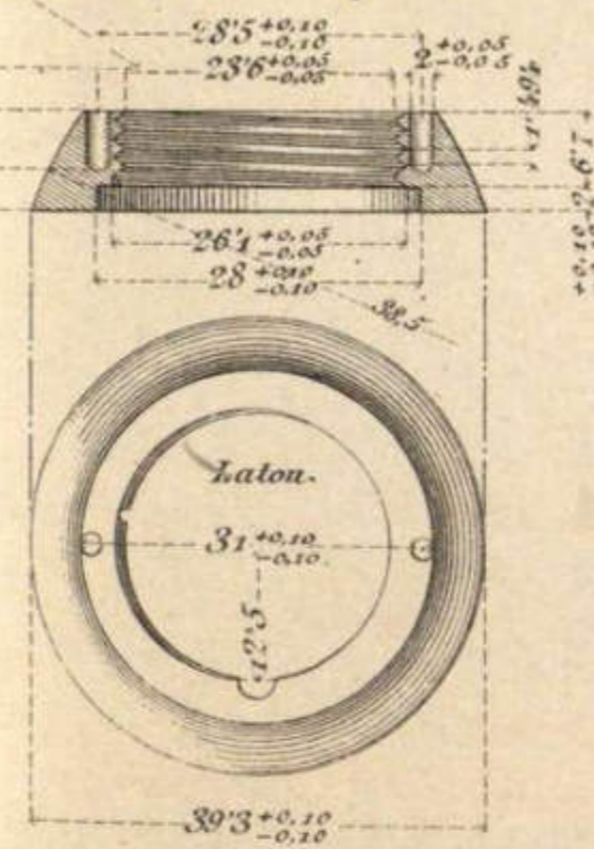

Pasadores de sujecion del regulador superior.

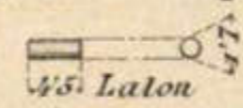

Tornillo de sujecion de la cabeza de apriete

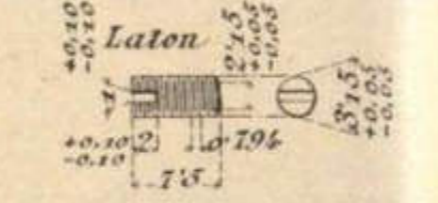

Regulador inferior.

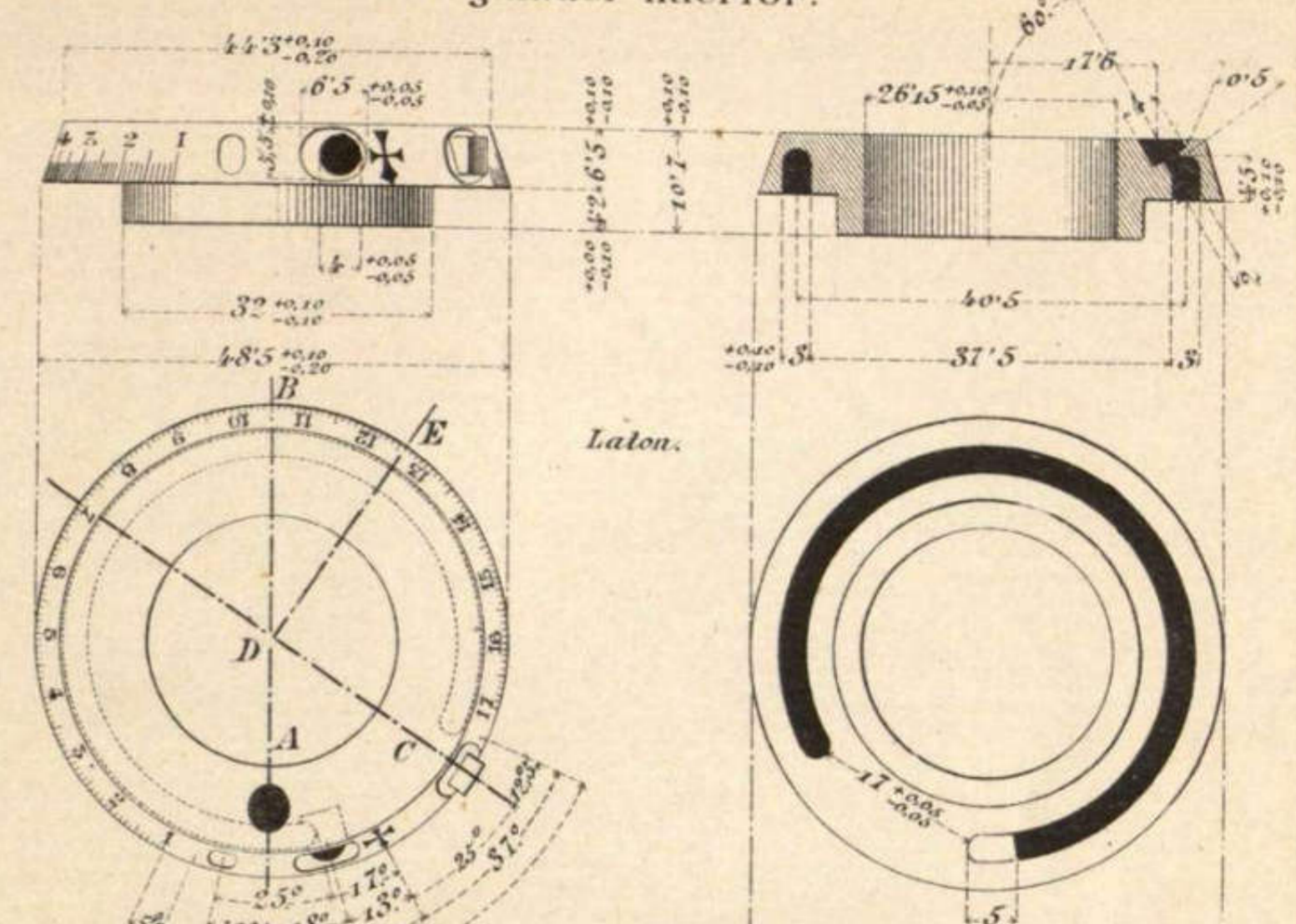

Seccion C. D. E.

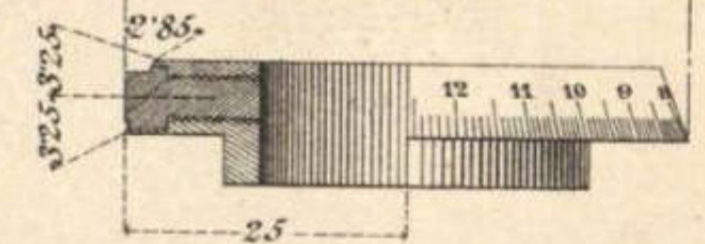

Teton de acero. Rosca izquierda.

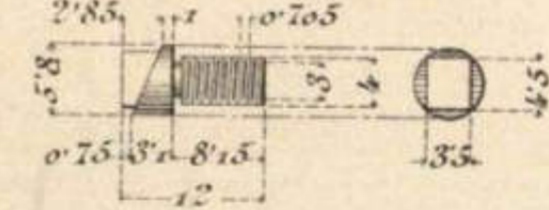

Regulador superior.

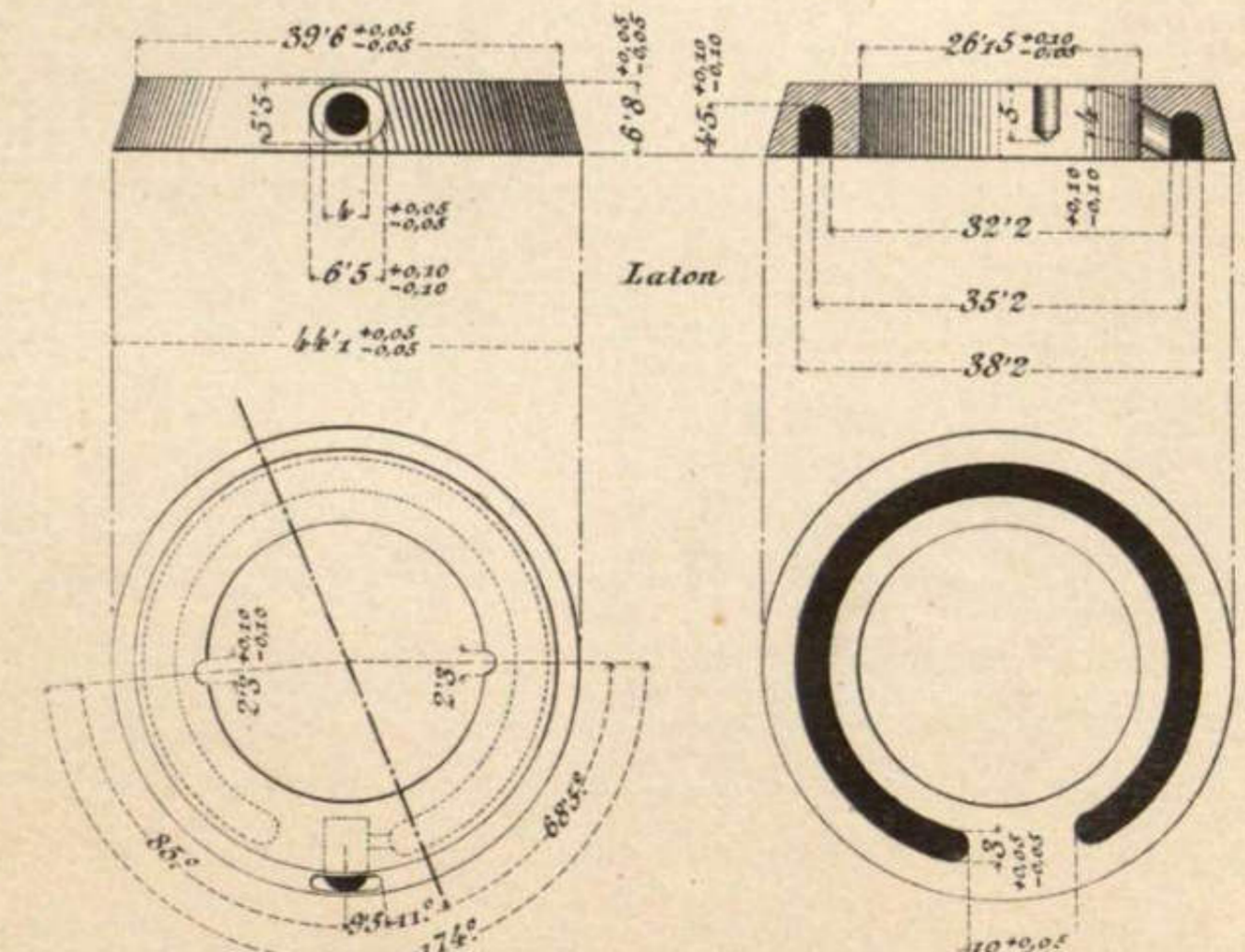

Cuerpo. Laton.

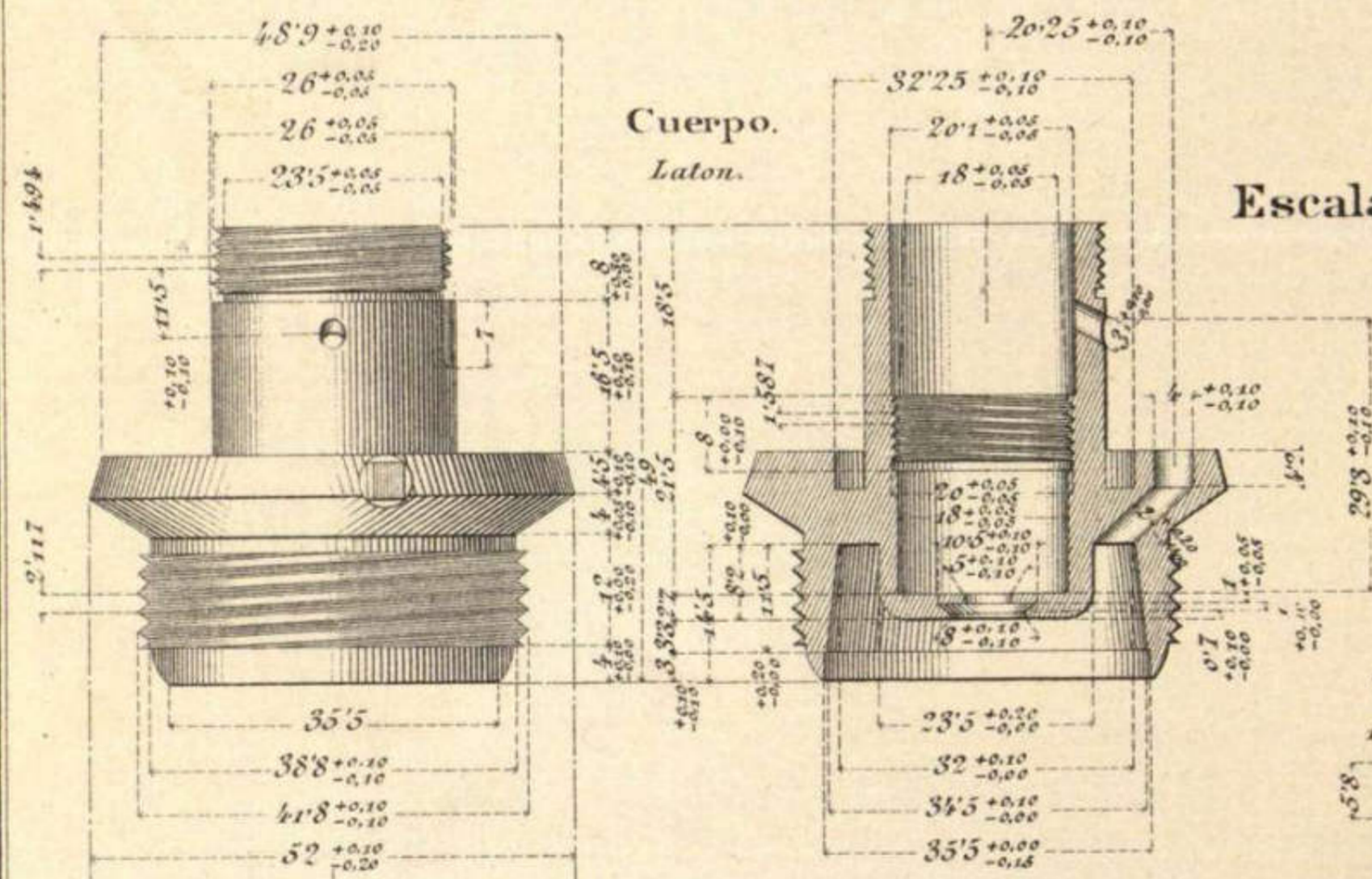

Escala 1/1.

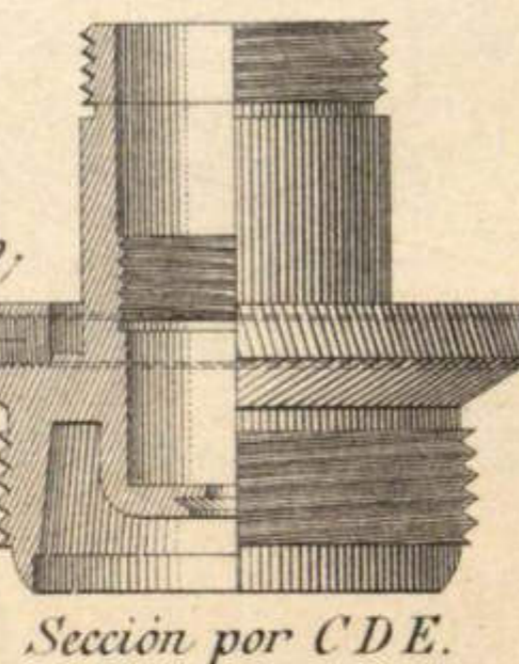

Seccion por C D E.

ESPOLETA DE DOBLE EFECTO MODELO 1907.

DETALLES.

Escala 1/4.

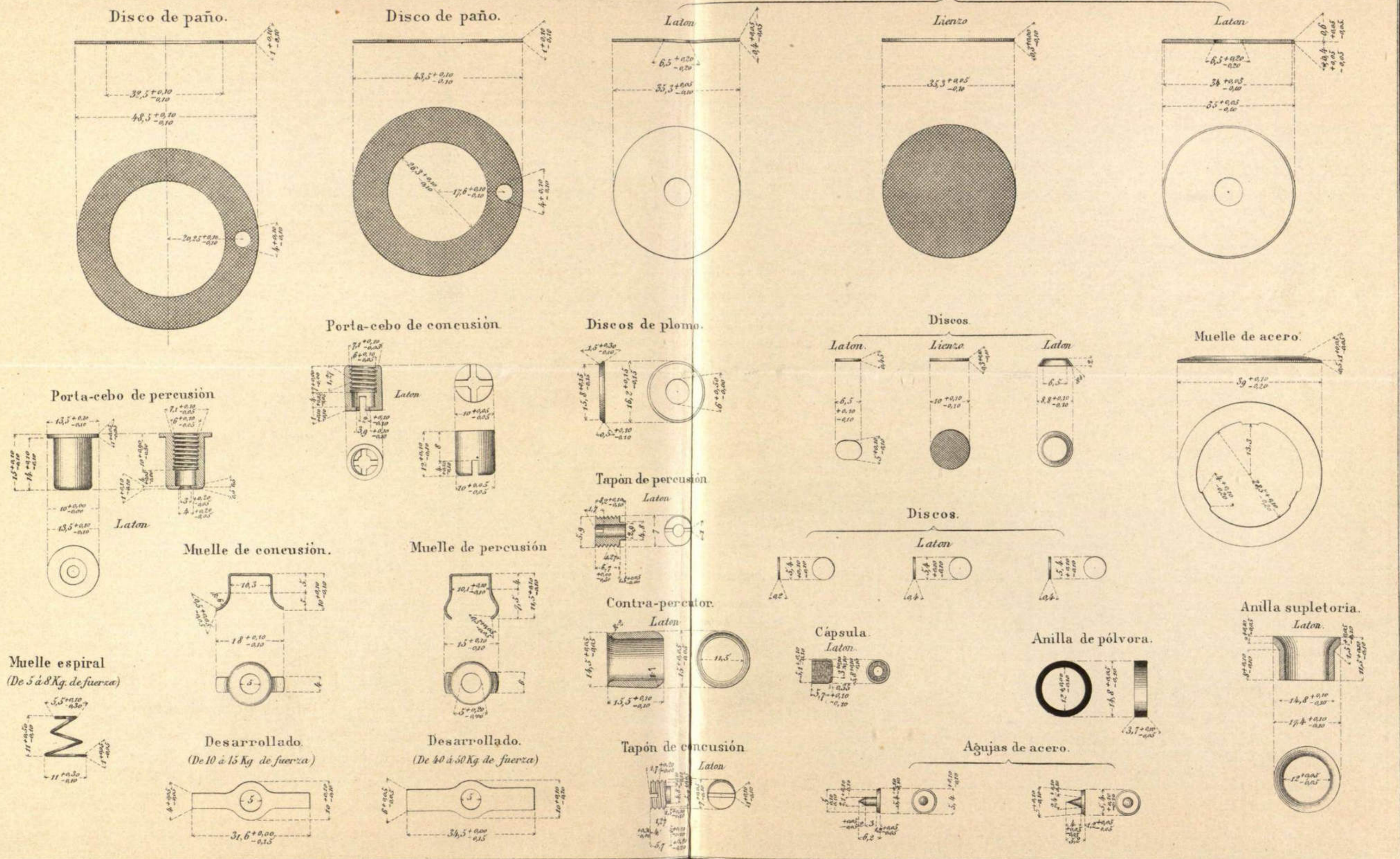

CUREÑA PARA CAÑÓN AG. T. r. DE 7' 5 gm. DE CAMPAÑA KRUPP.

CAJAS DE ENTRE GUALDERAS

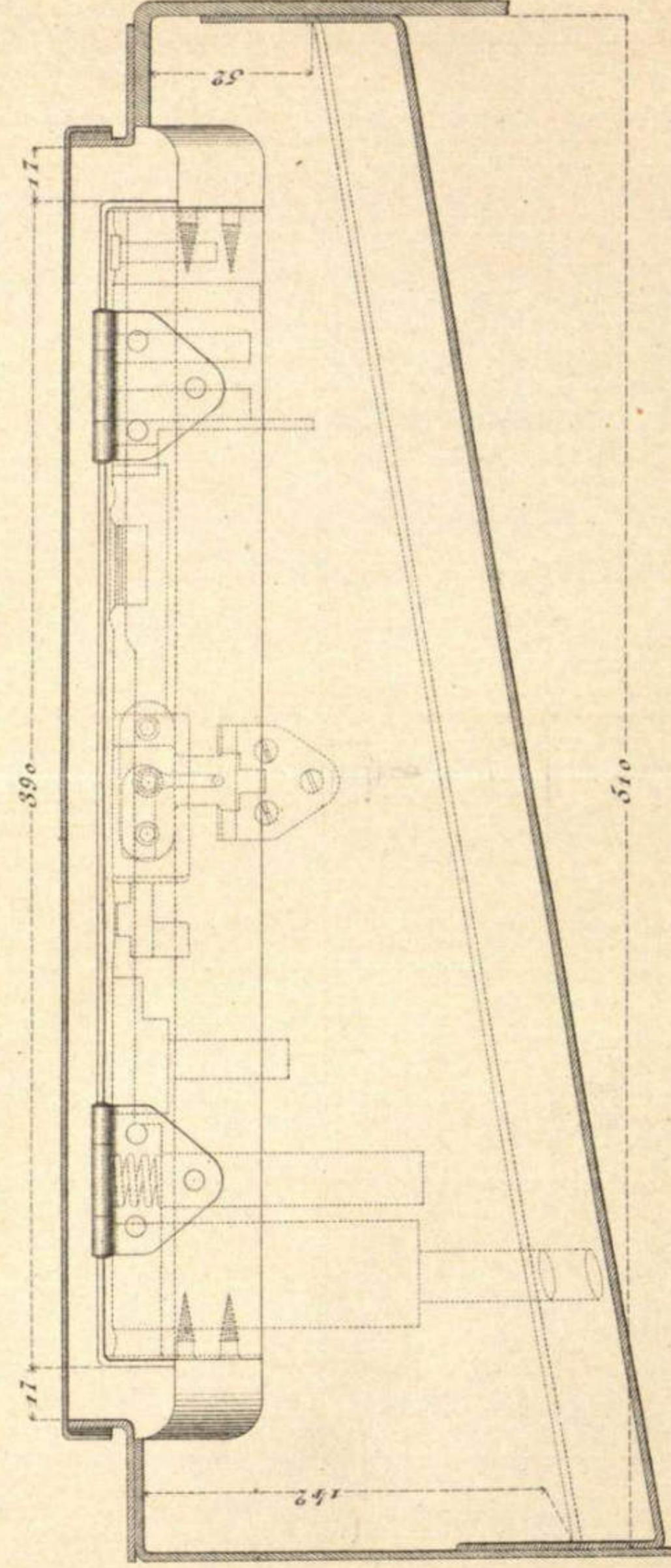

510

Escala 4/10

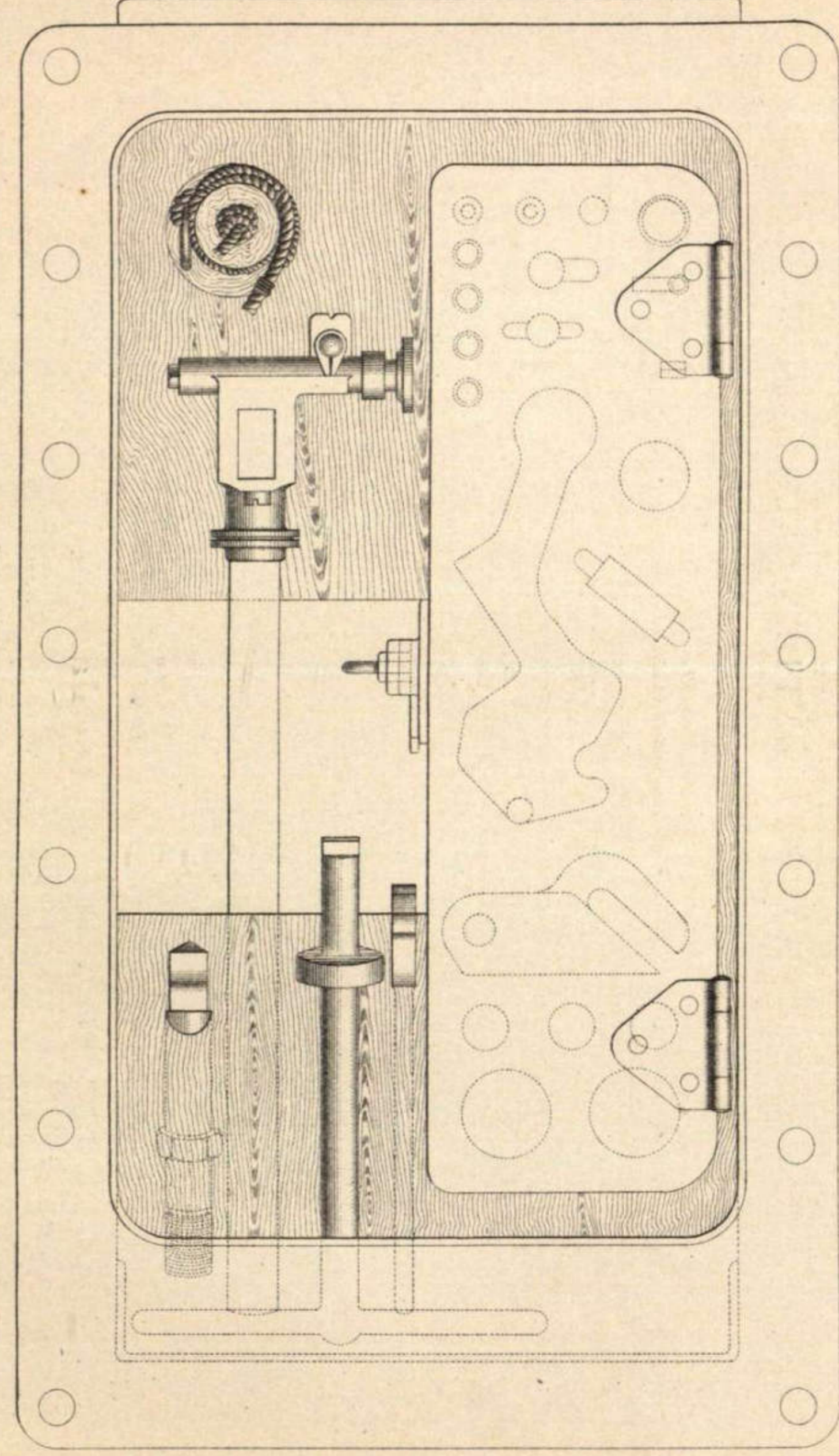
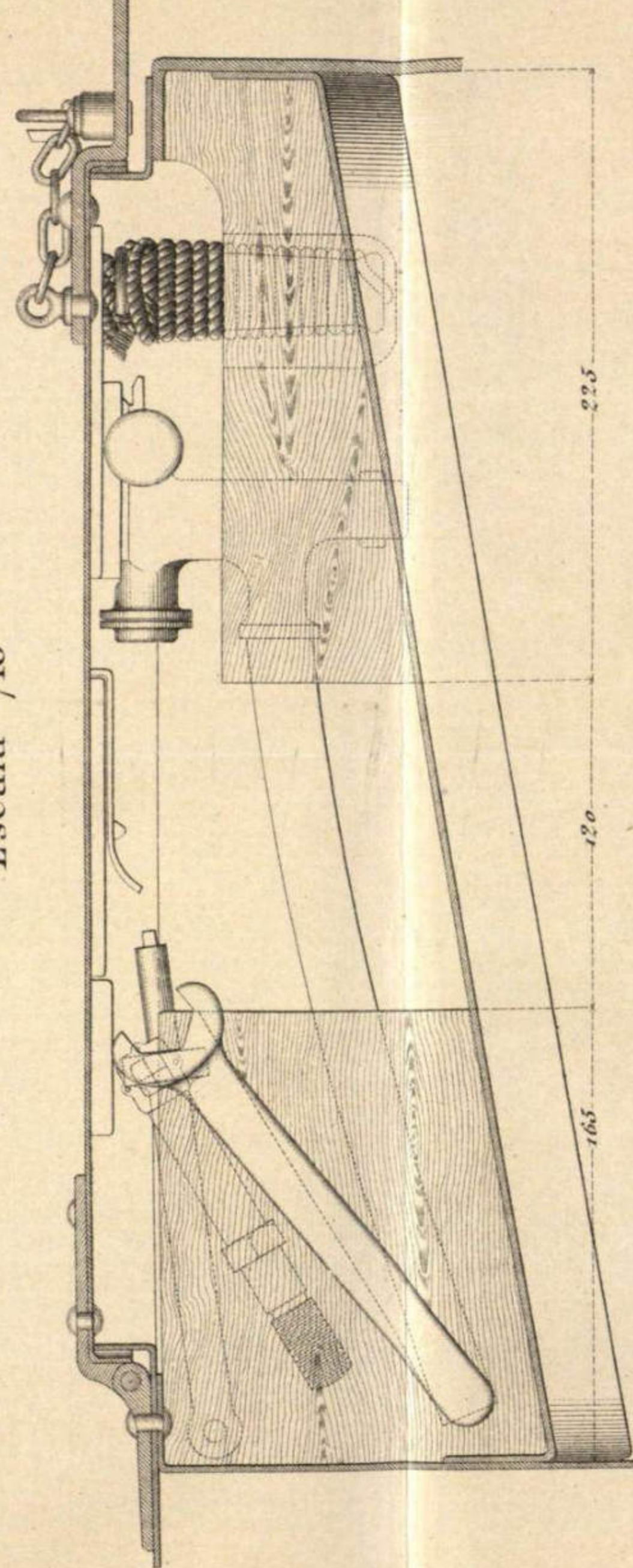

CAJAS DE RESPETOS PARA MATERIAL KRUPP Y SAINT-CHAMOND

JUEGOS DE ARMAS Y ACCESORIOS

Escala $\frac{3}{10}$

Caja derecha del armón de la pieza.

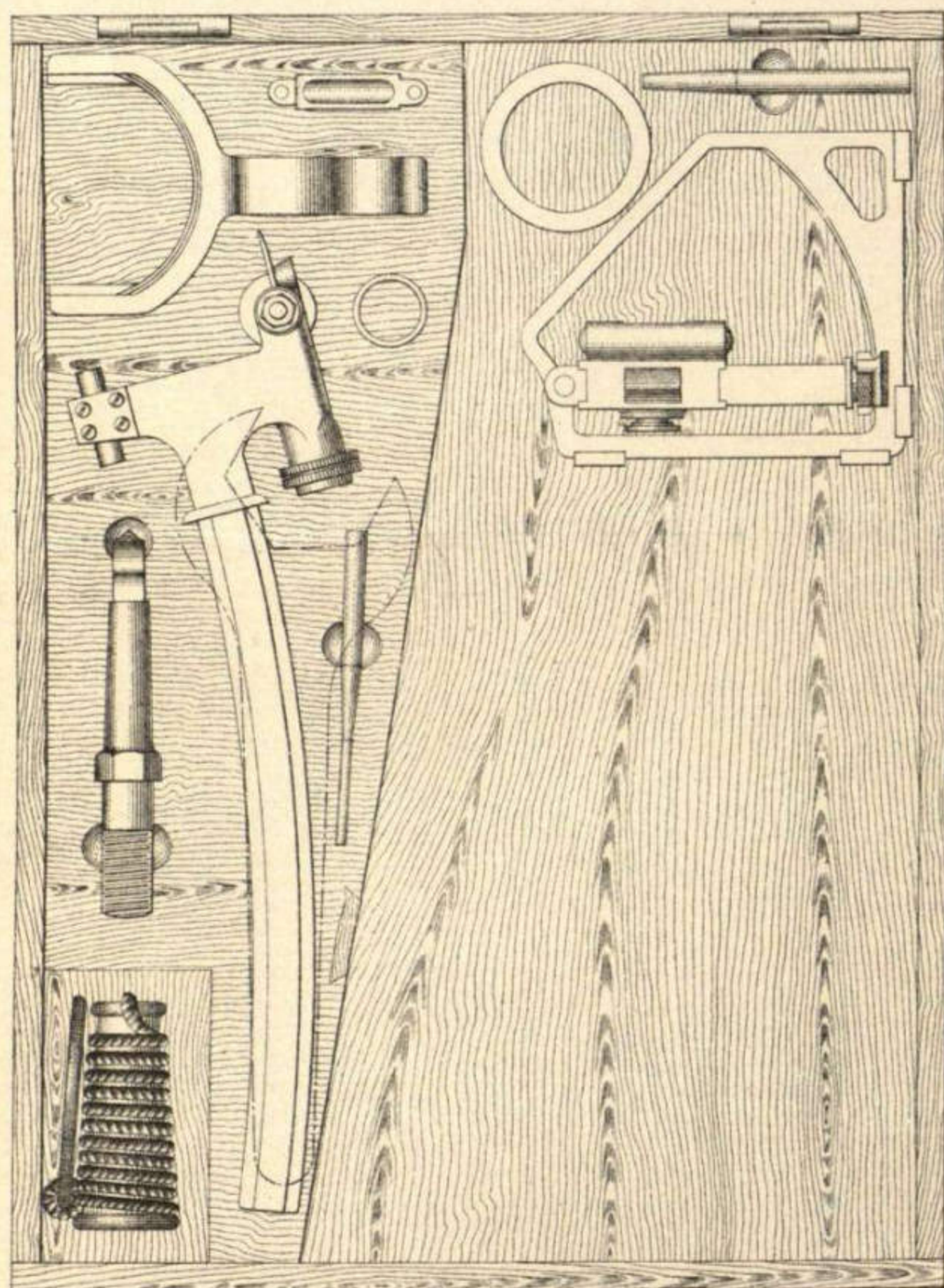

Cajas centrales de arzones y carros.

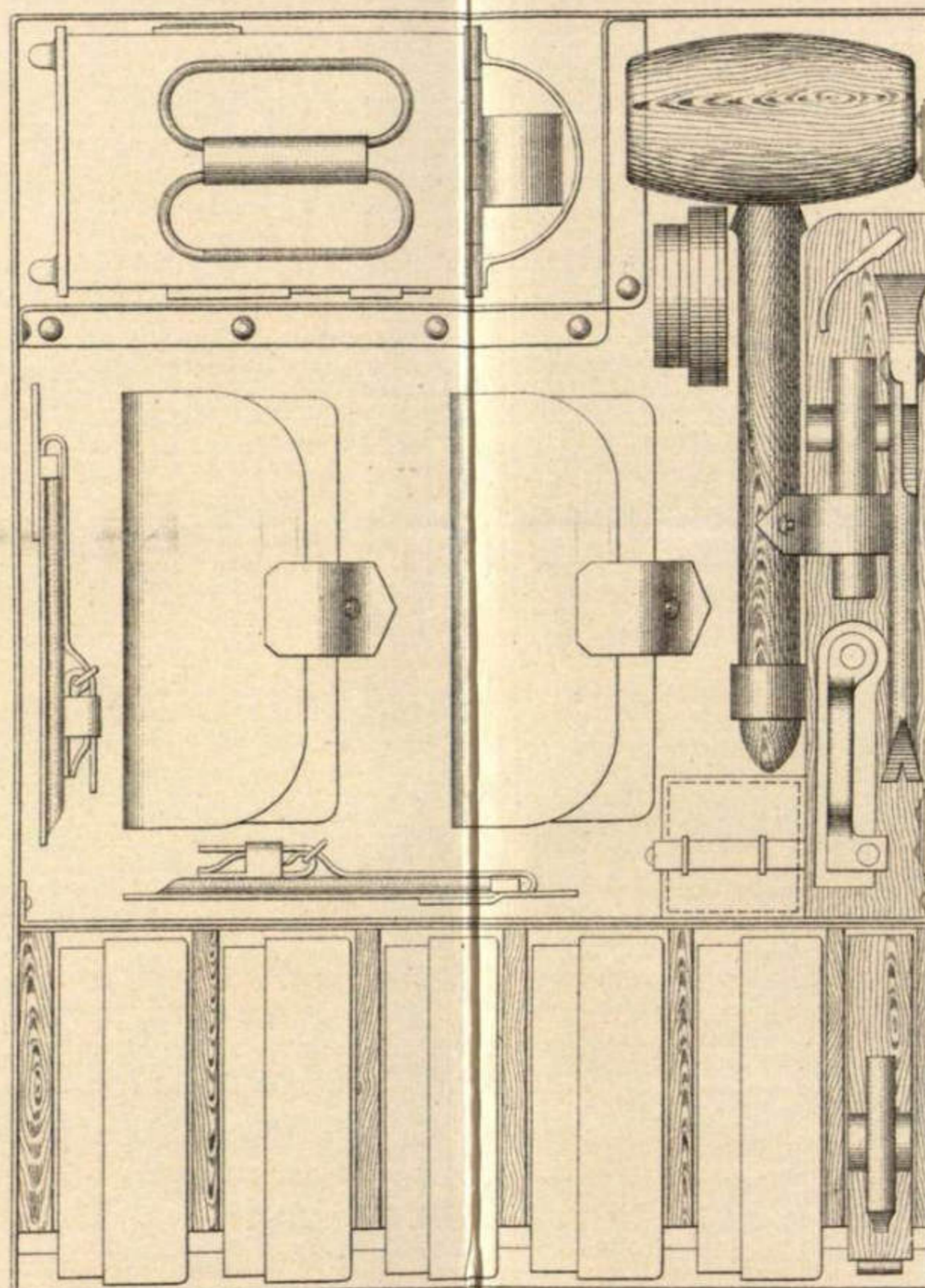

Caja izquierda de los arzones.

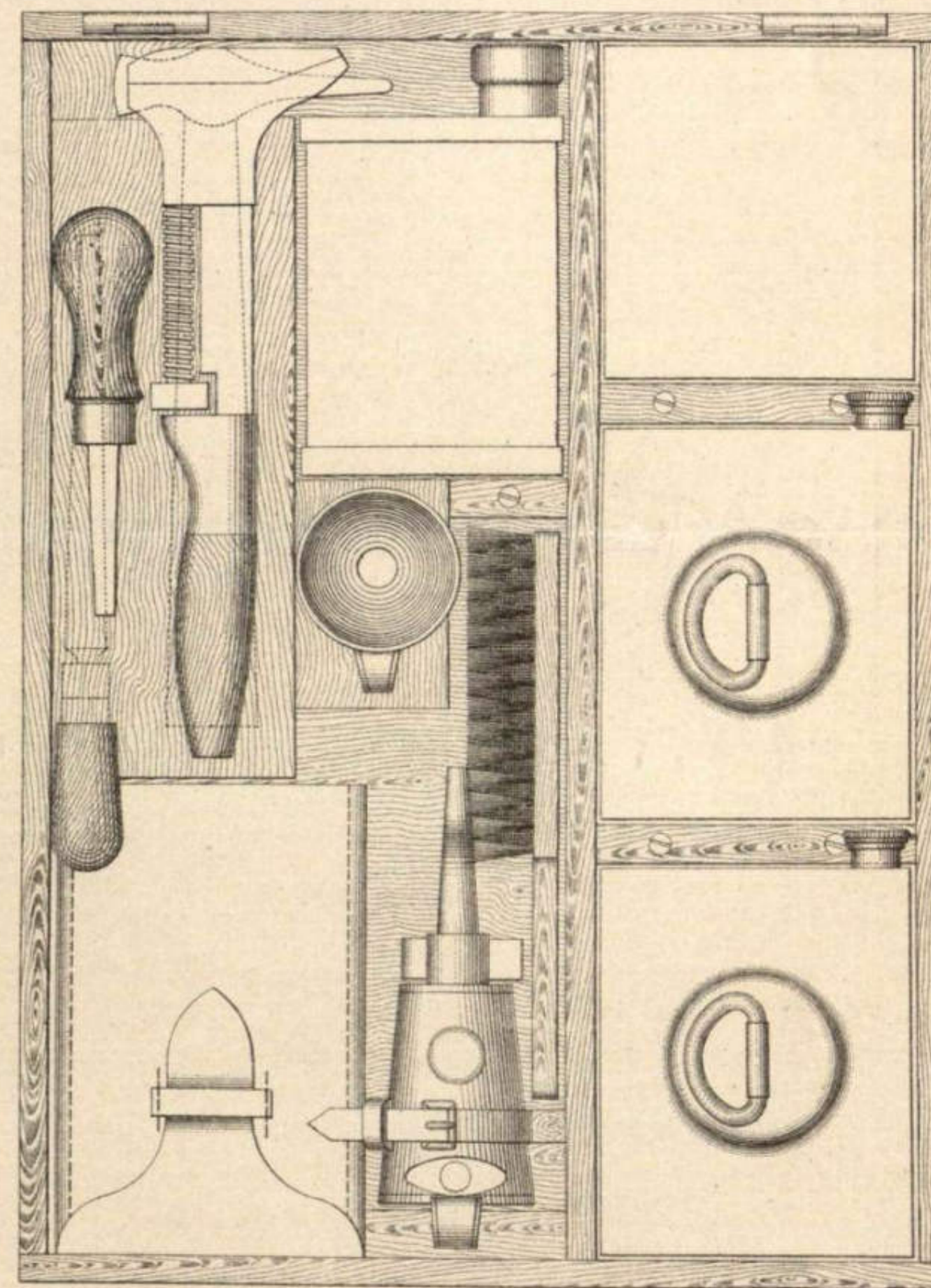

CAÑON Ac. T. r. DE 7'5 cm. DE CAMPAÑA Md. 1906.

VISTA VERTICAL

Escala 1/10.

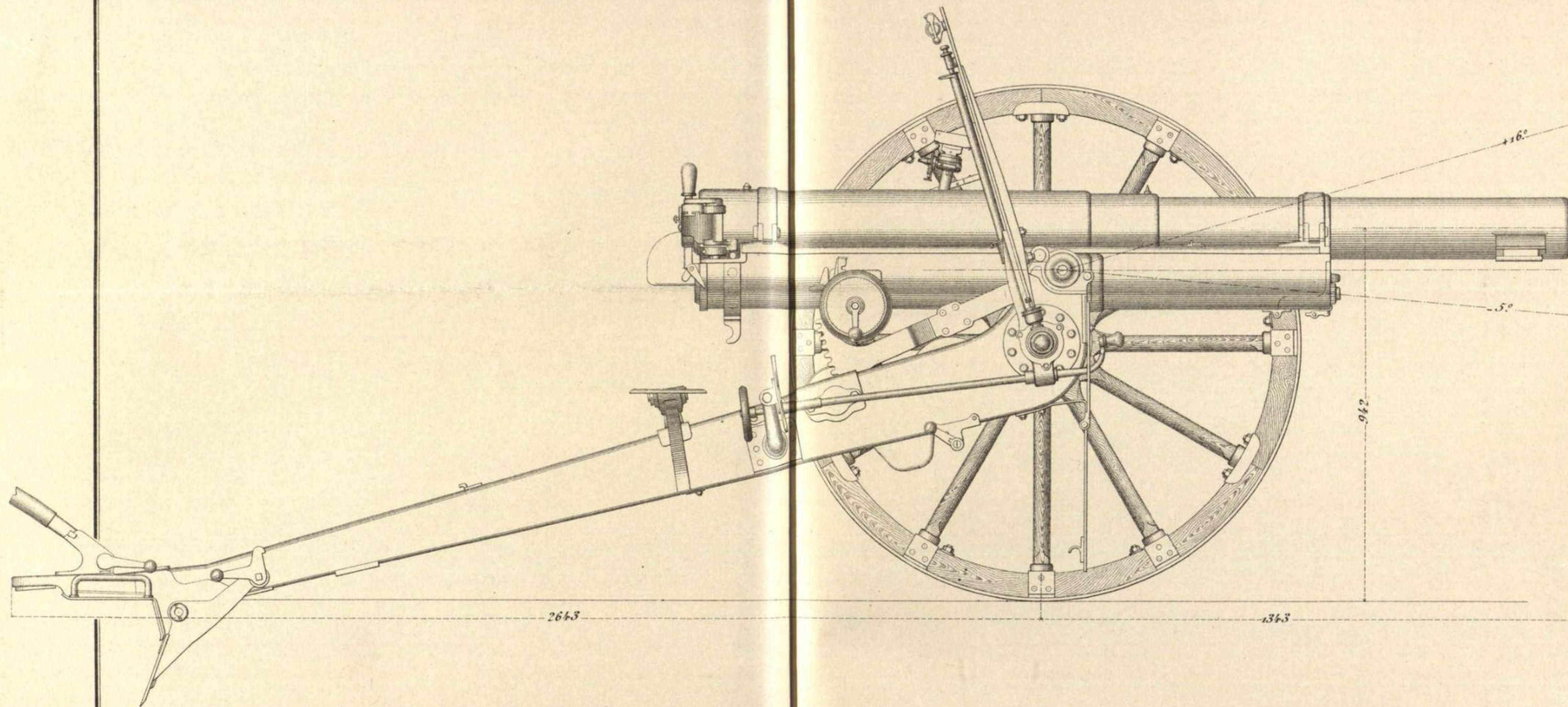

CAÑON Ac. T. r. DE 7'5 cm. DE CAMPAÑA Md. 1906.

VISTA HORIZONTAL

Escala 1/10.

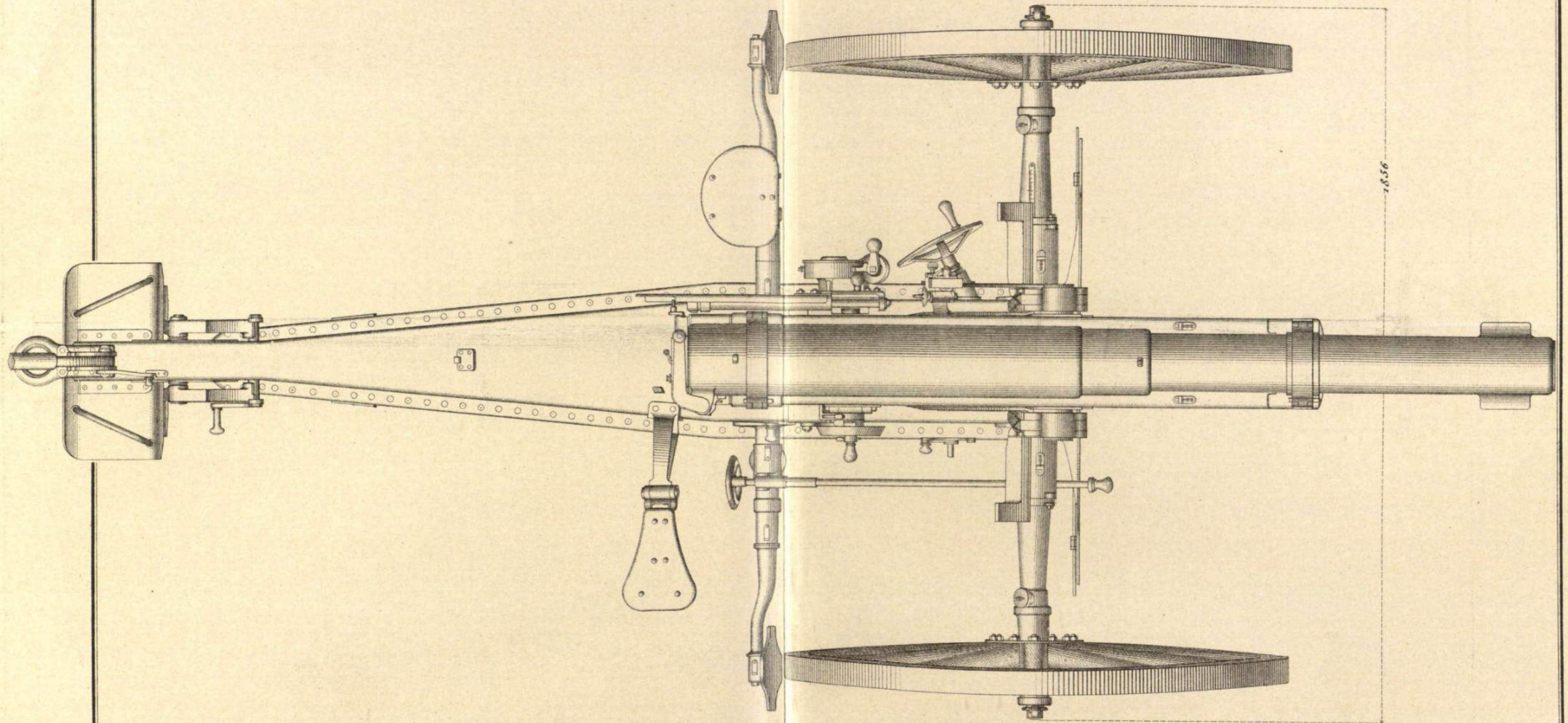

CAÑON Ac. T. r. DE 7'5 cm. DE CAMPAÑA Md. 1906.

DETALLES.

Escala $\frac{5}{10}$.

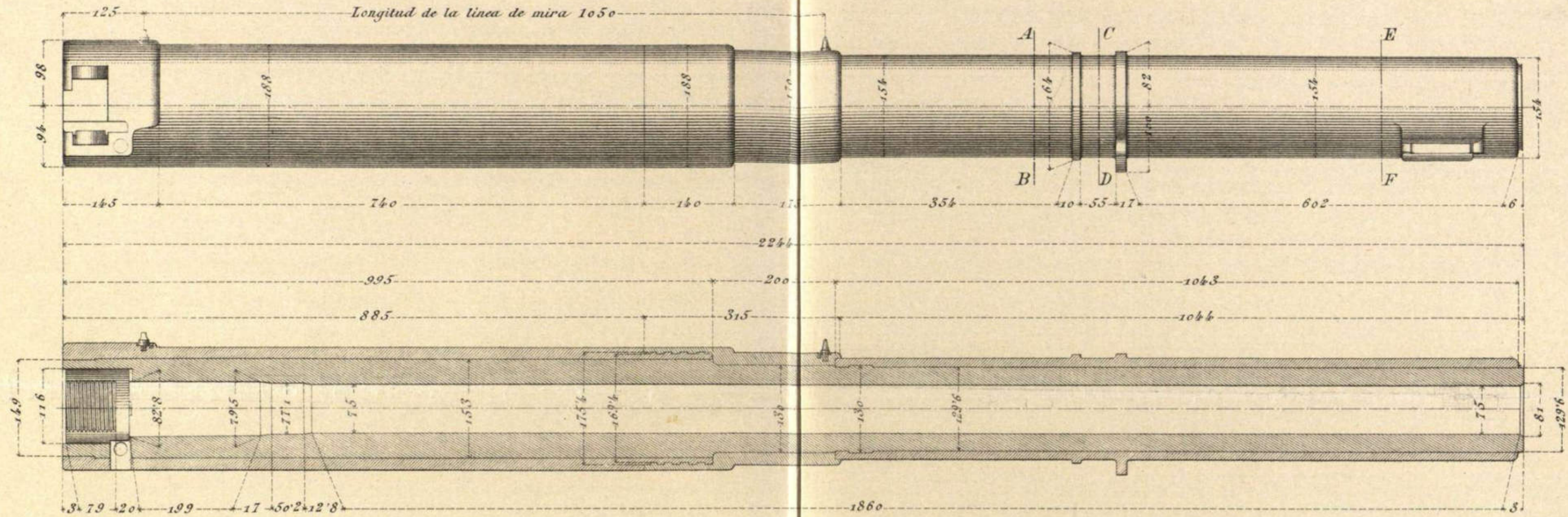

E = $\frac{5}{10}$.

Corte por A. B.

Corte por C. D.

Corte por E. F.

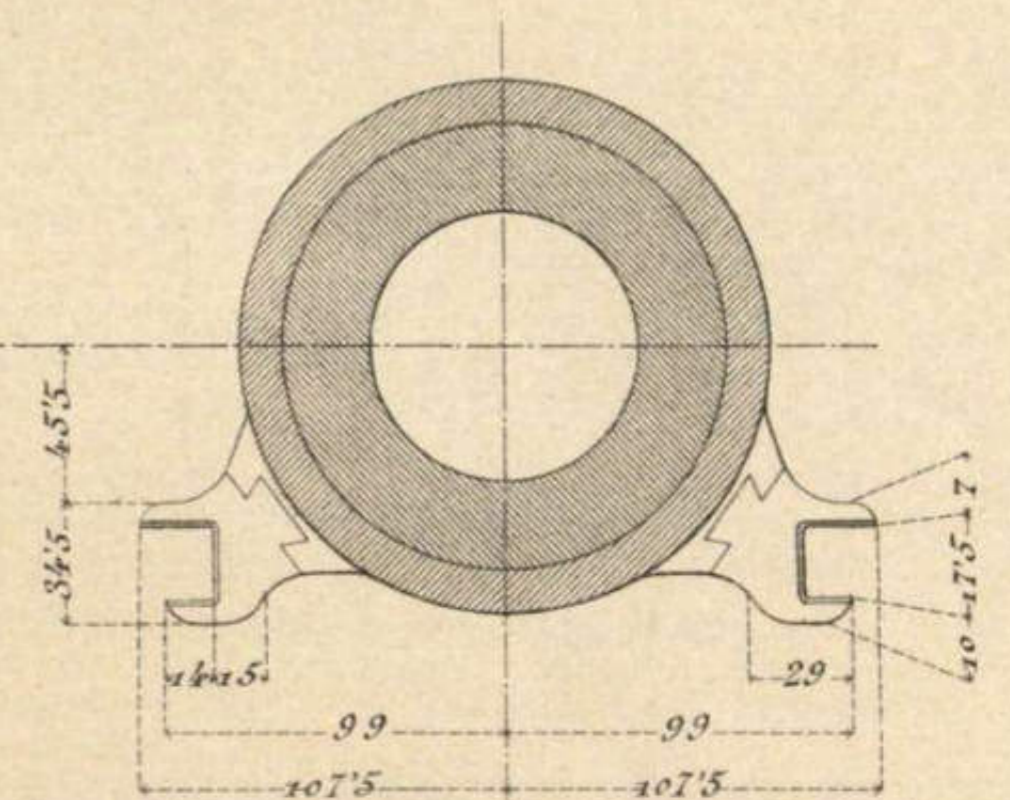
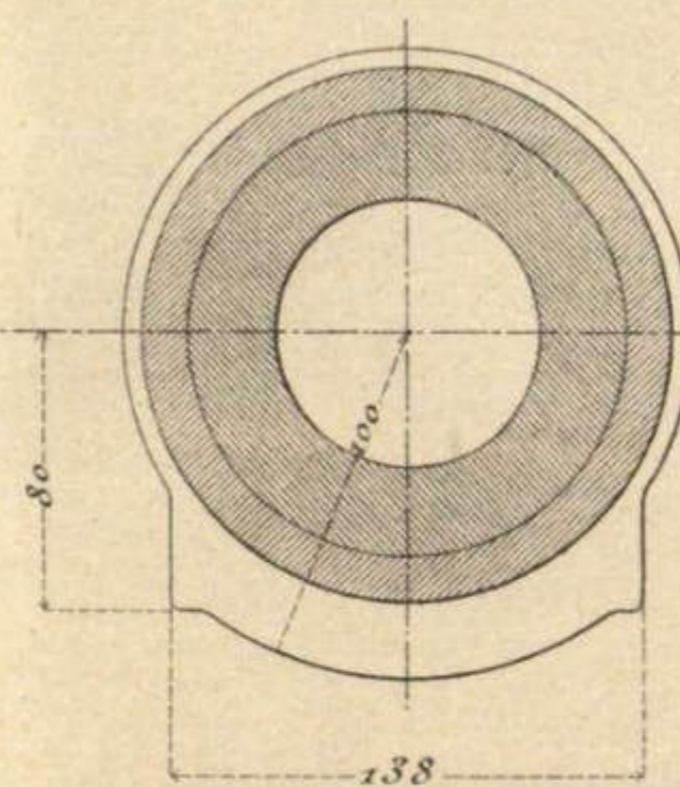
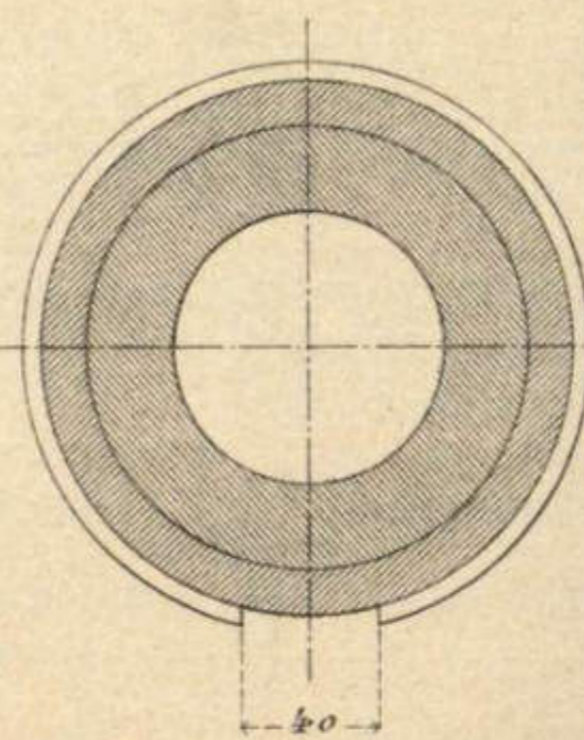
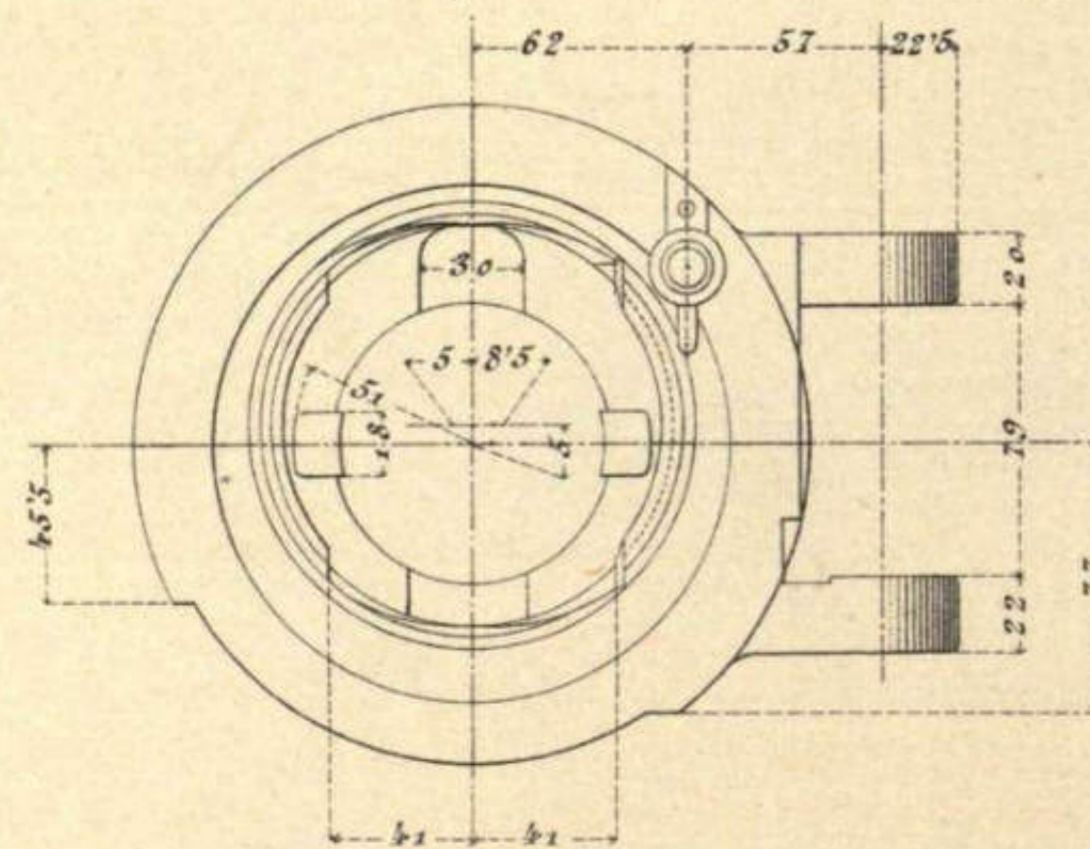

CAÑON Ac. T. r. DE 7'5 cm. DE CAMPAÑA Md. 1906.

DETALLES.

Plano de la boca. E=5/10

Recámara. E=5/10.

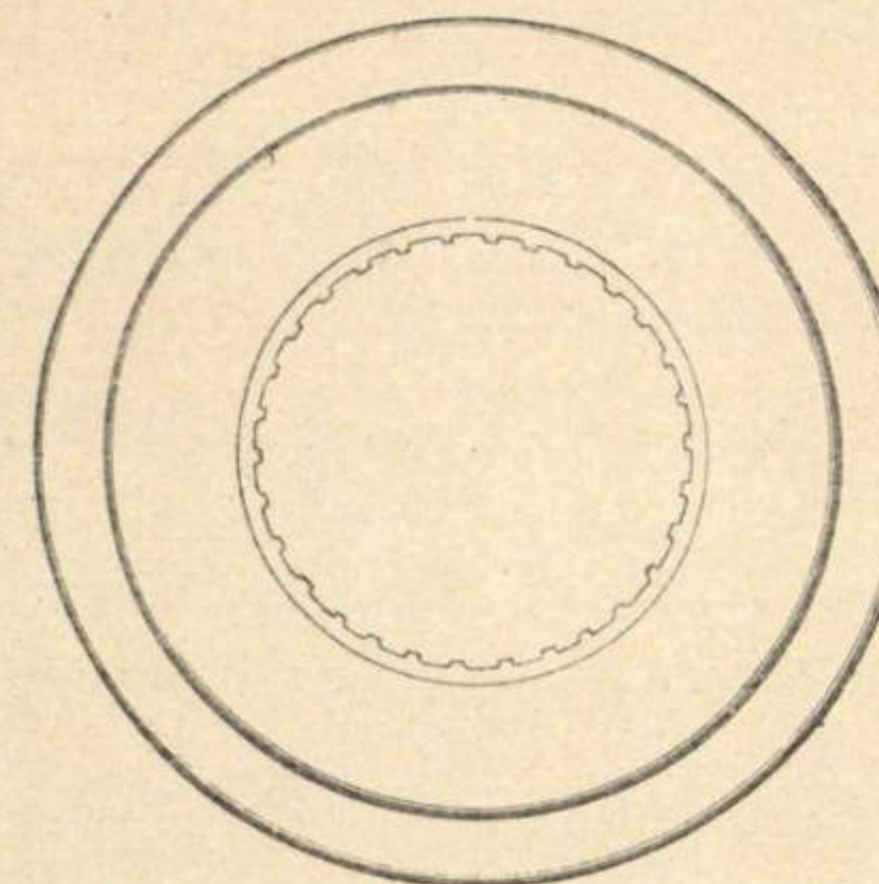
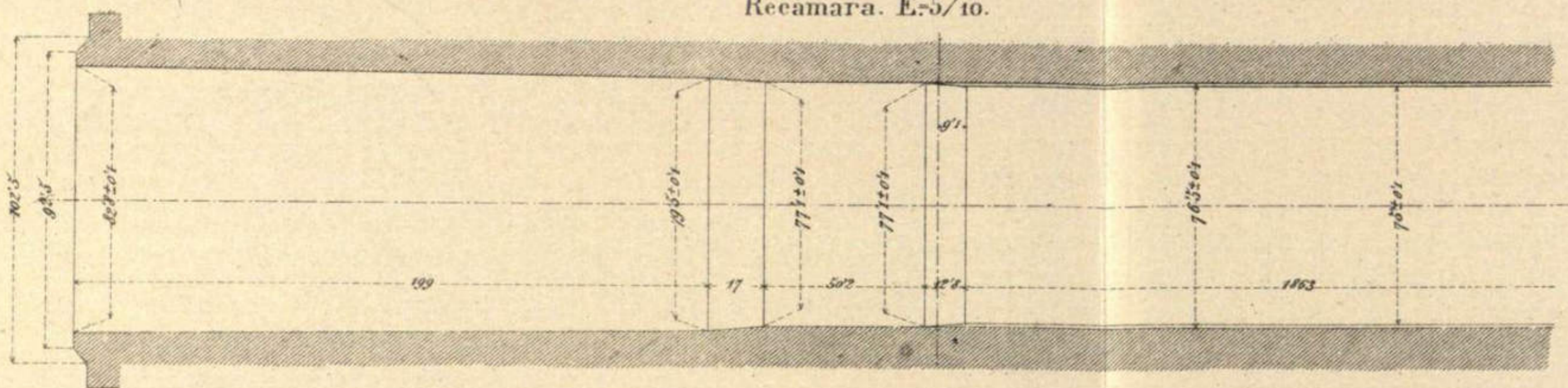

Alojamiento del proyectil en la recámara E=2/1

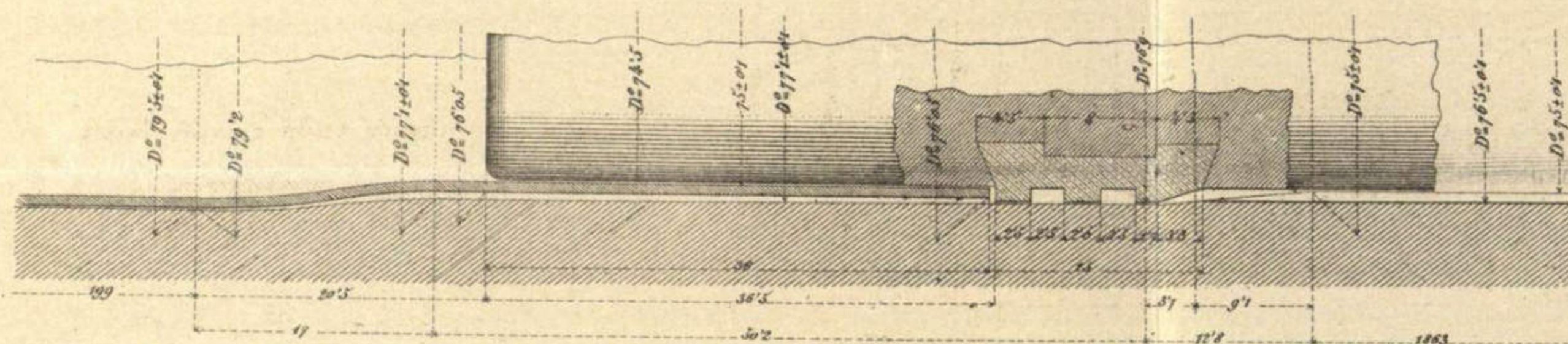

Rayado en la culata. E=5/1

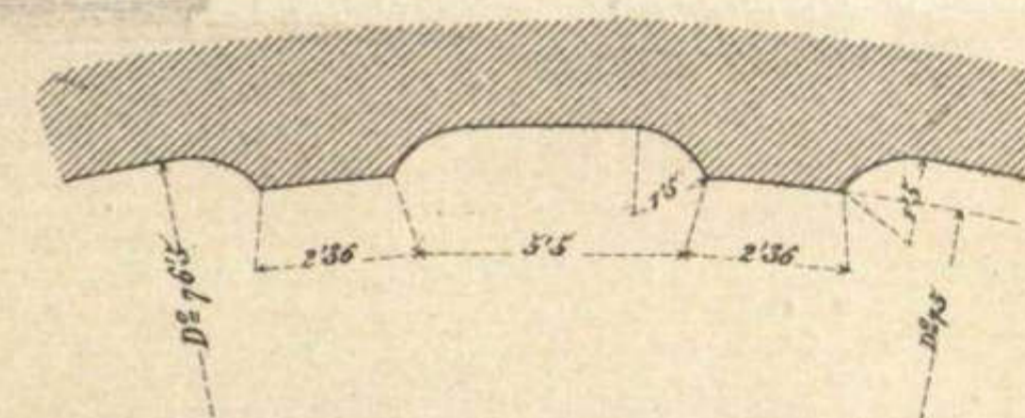

Trazado de la raya

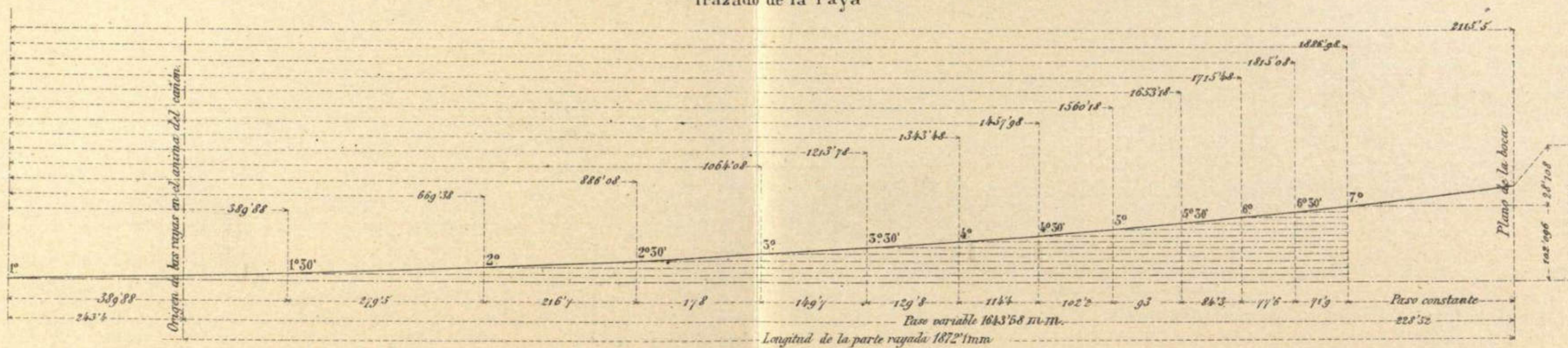

CAÑON Ac. T. r. DE 7'5 cm. DE CAMPAÑA Md. 1906.

DETALLES

Escala 5/10.

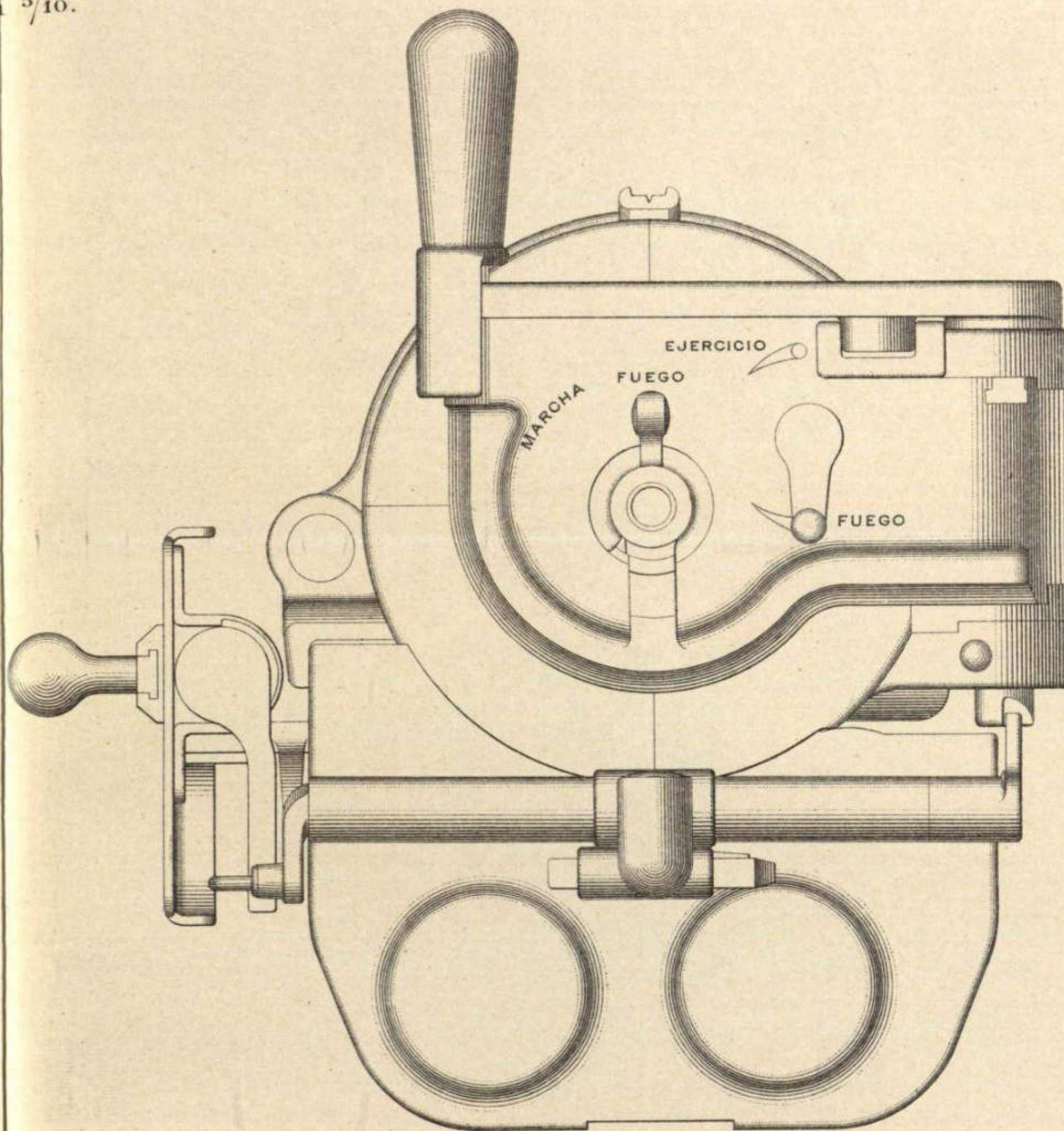
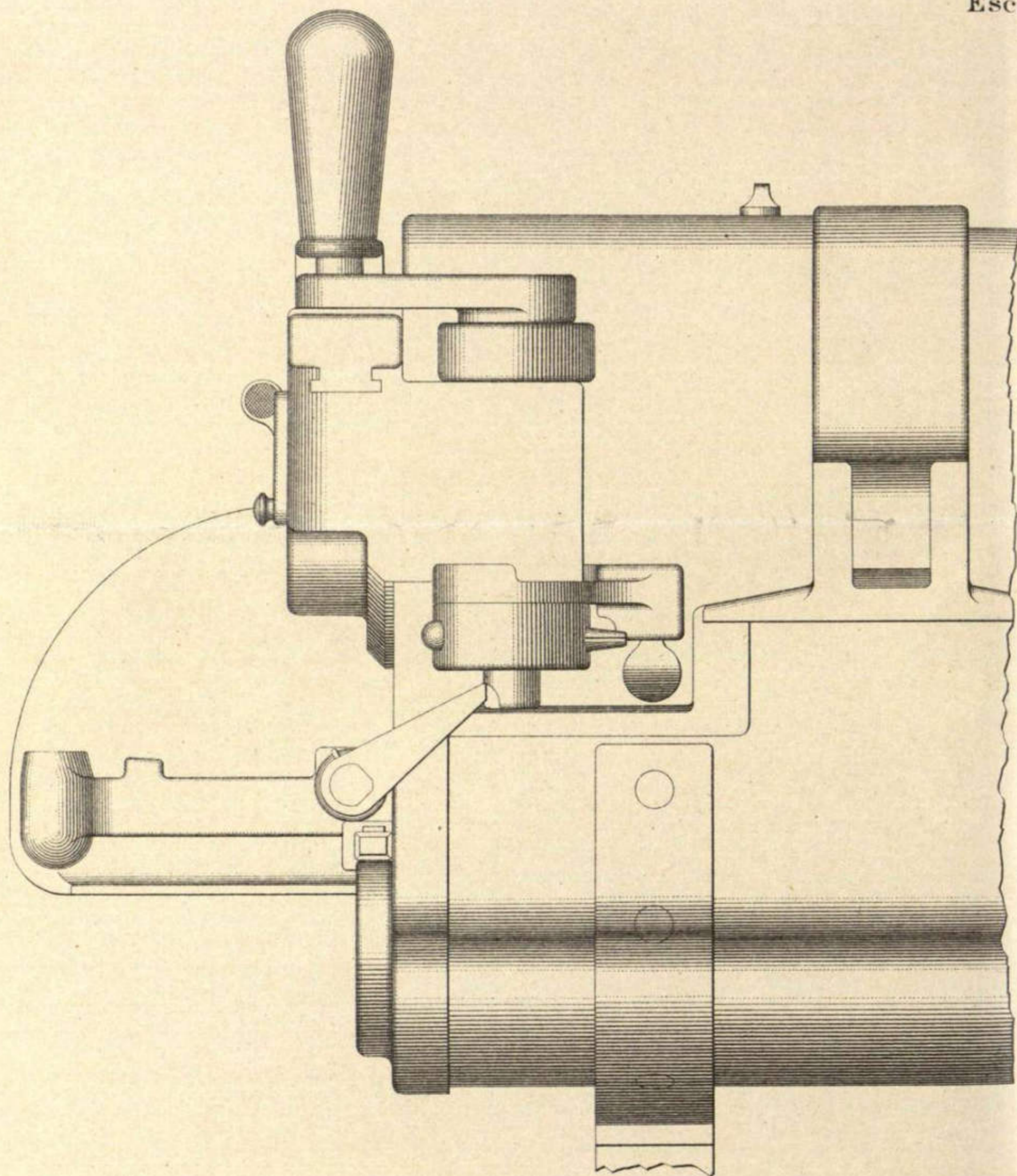

CAÑÓN Ac. T. r. DE 7'5 cm. DE CAMPAÑA Md. 1906.

DETALLES.

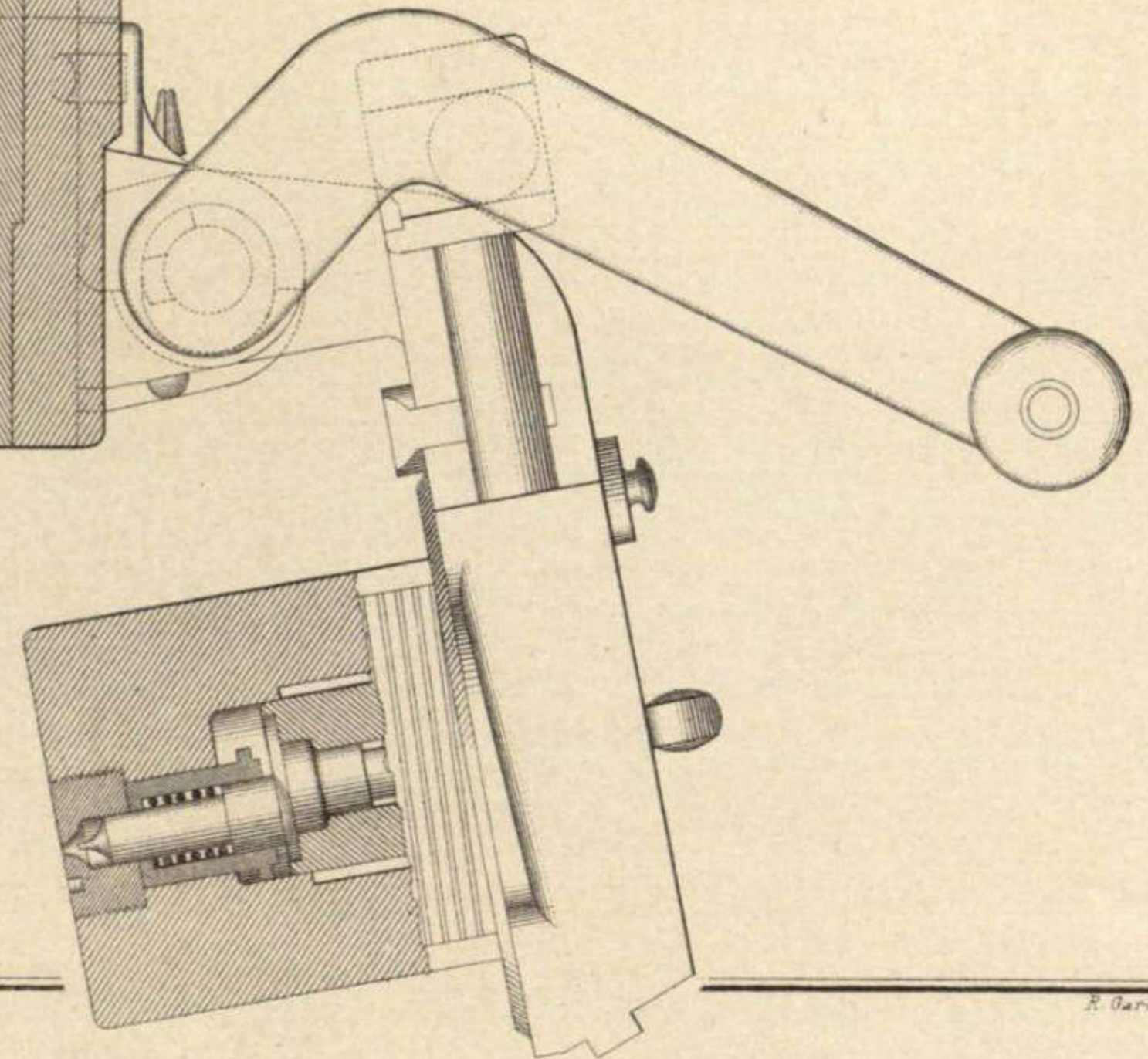
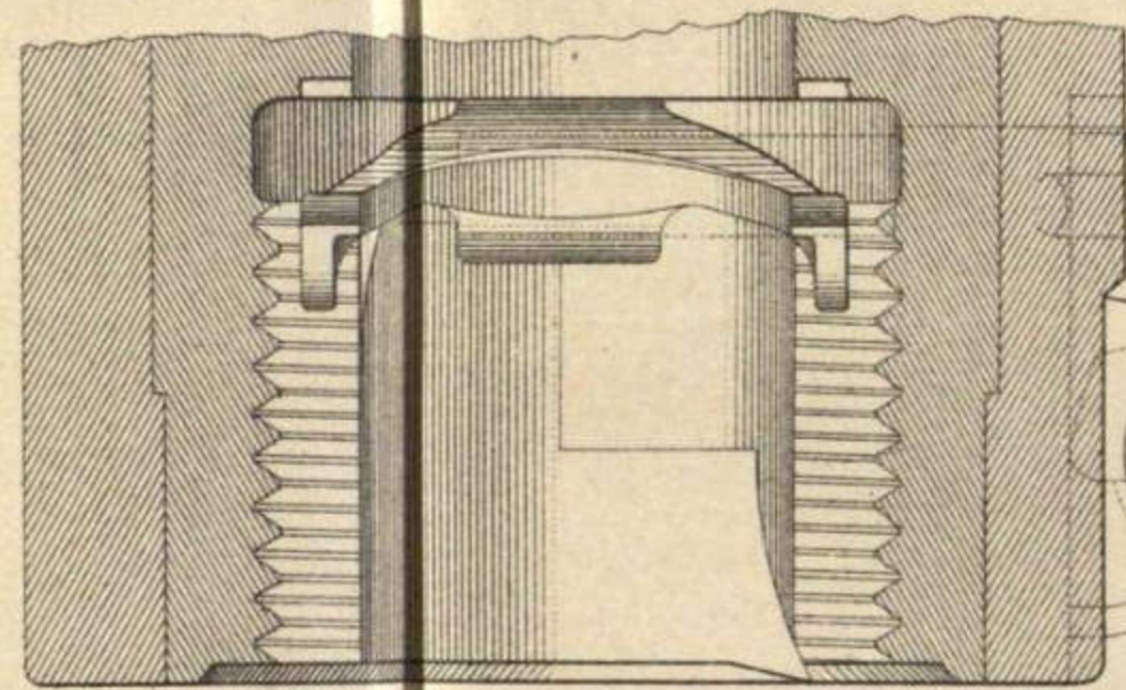
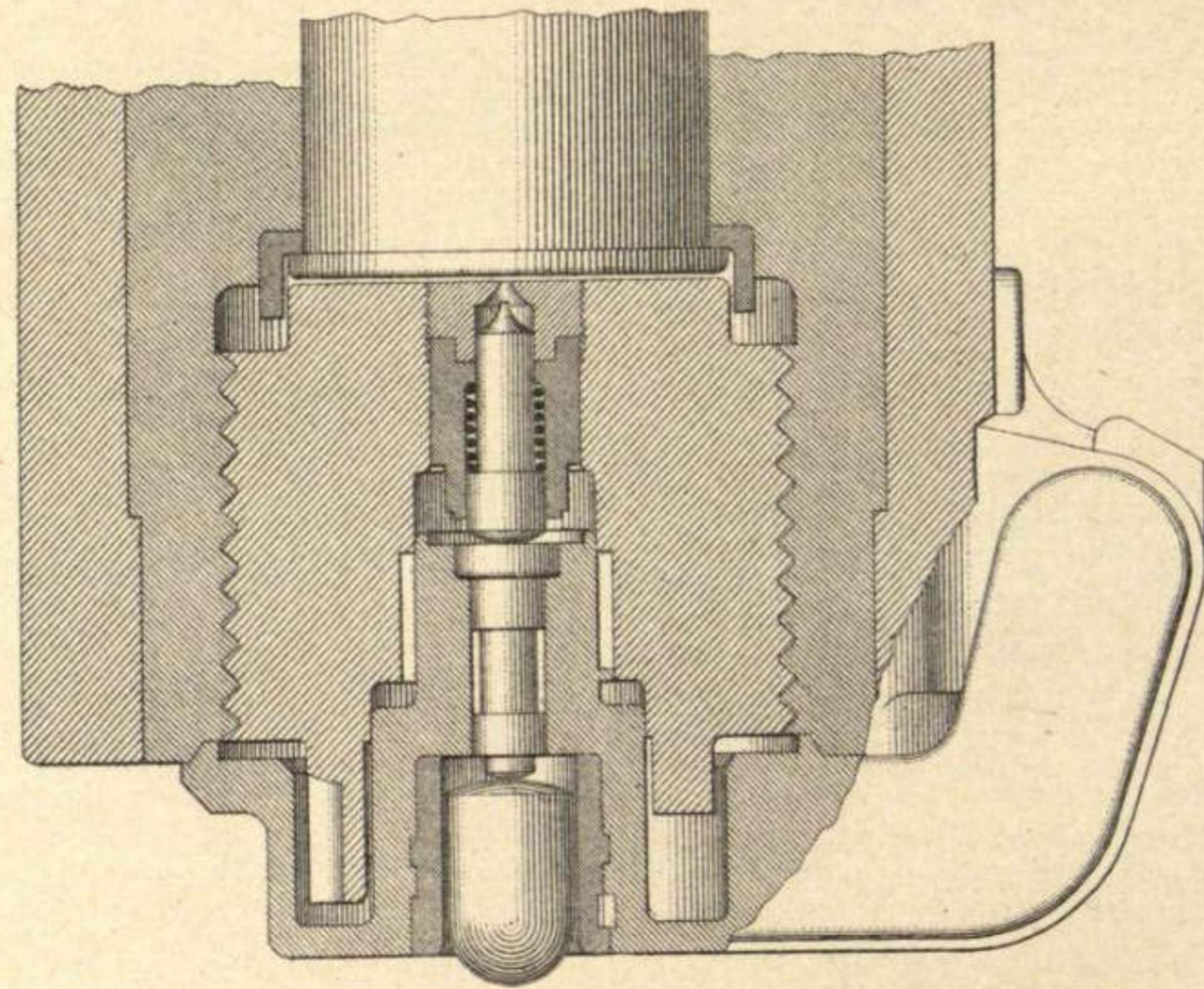
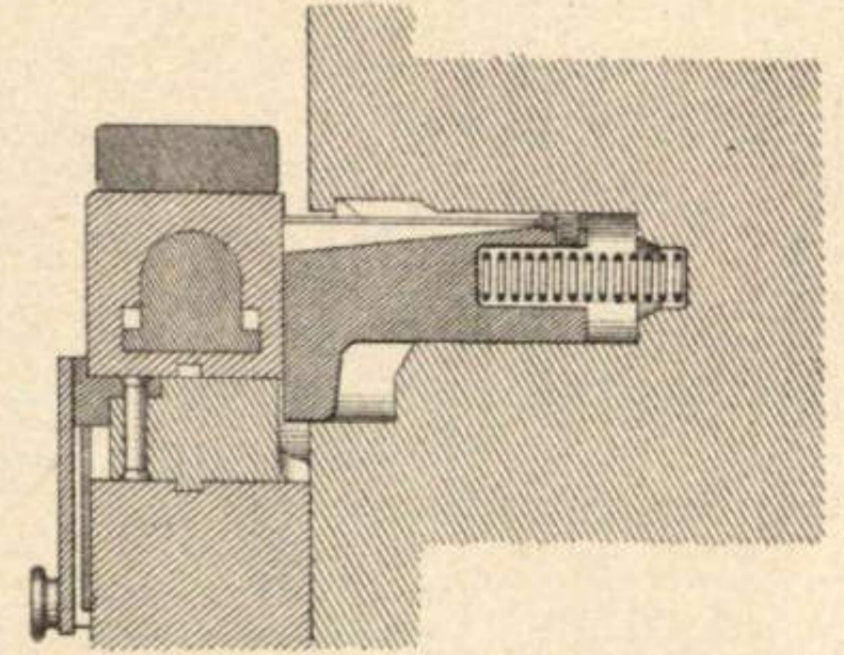
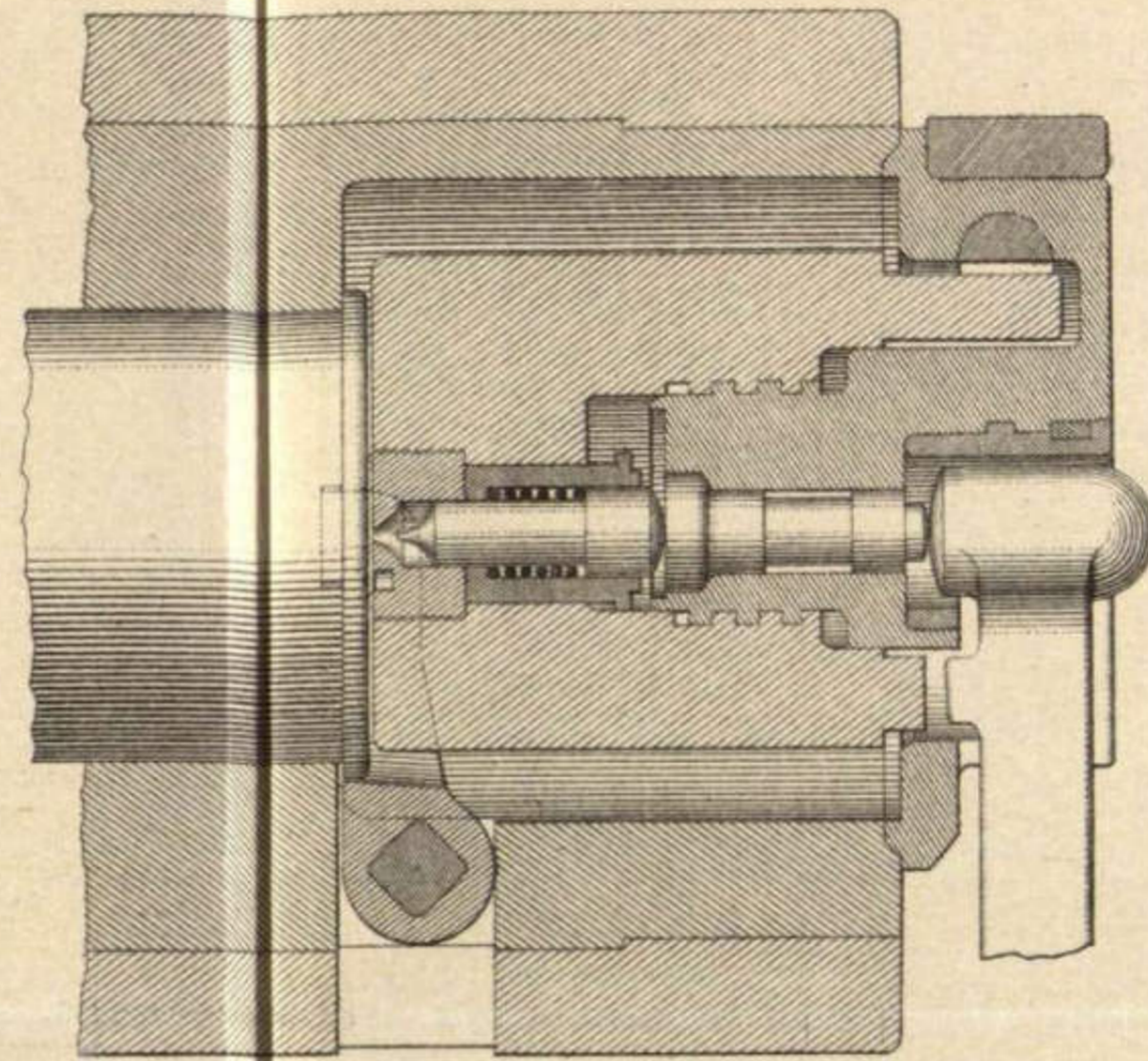
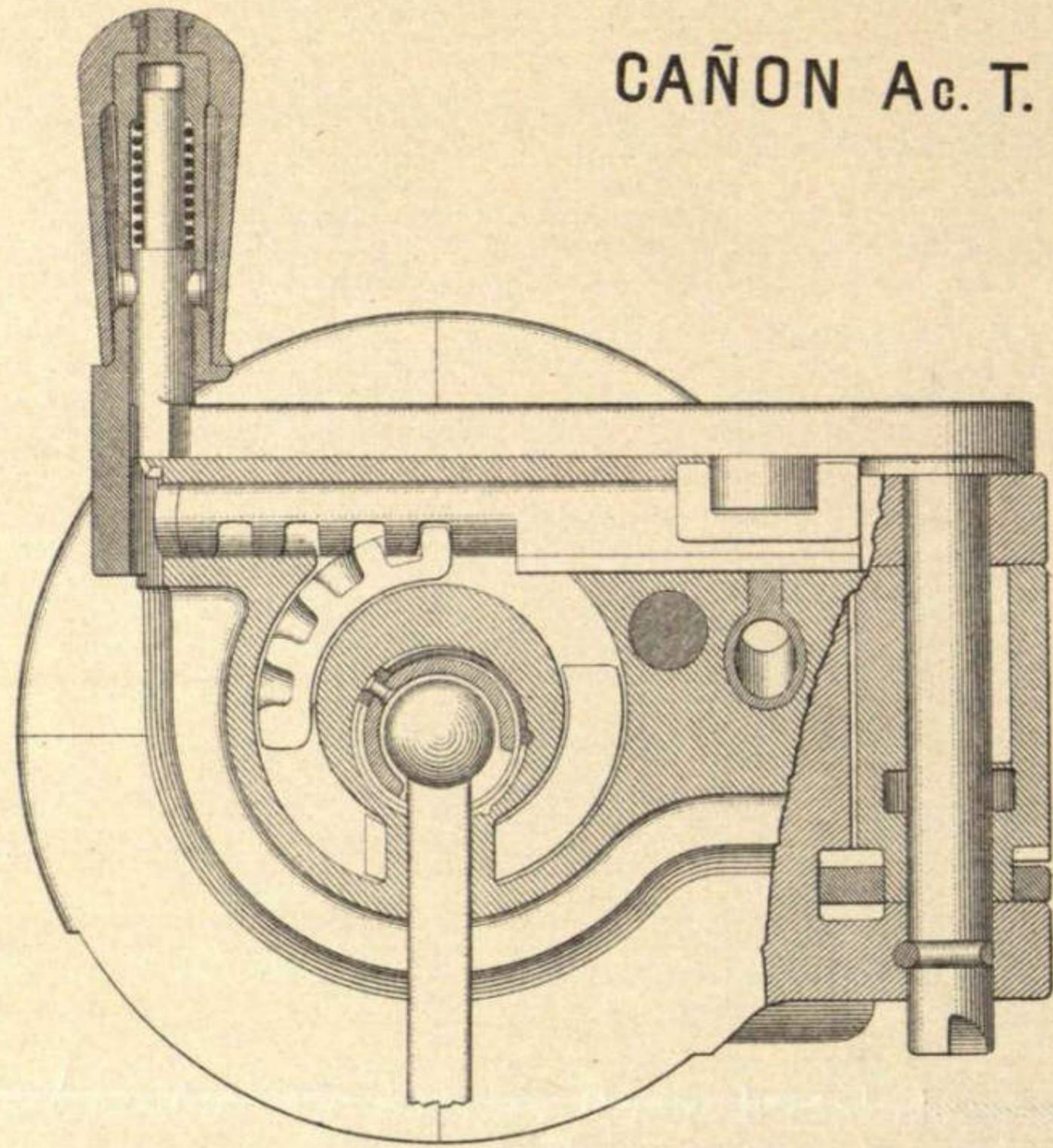

Escala 5/10.

CUREÑA PARA CAÑÓN Ac. T. r. DE 7'5 cm. DE CAMPAÑA Md. 1906.

DETALLES

Escala 1/10.

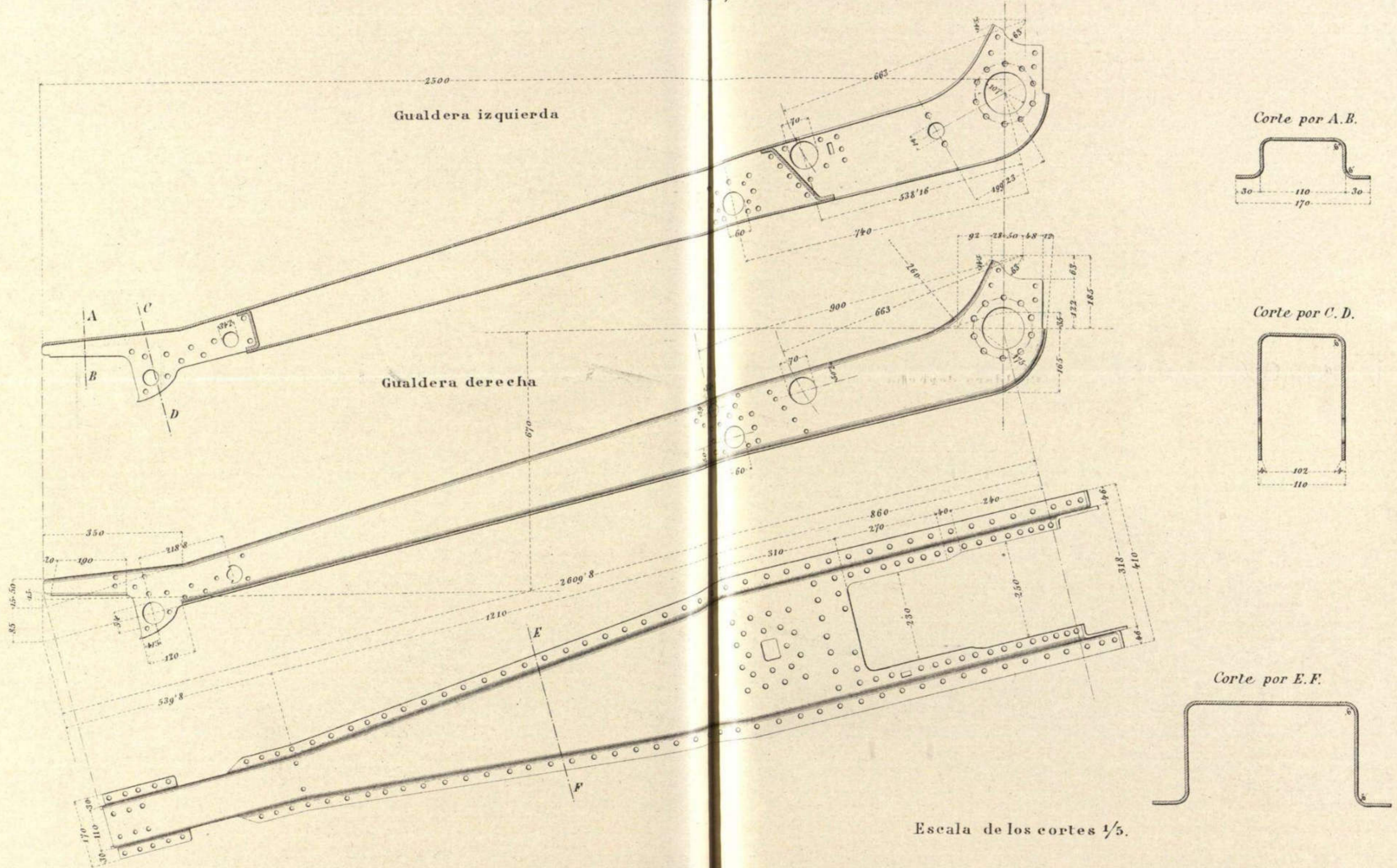

Escala de los cortes 1/5.

CUREÑA PARA CAÑÓN A.C.T.R. DE 7'5 cm. DE CAMPAÑA M.d. 1906.

DETALLES

Chapa de fondo. (E.-1/10.)

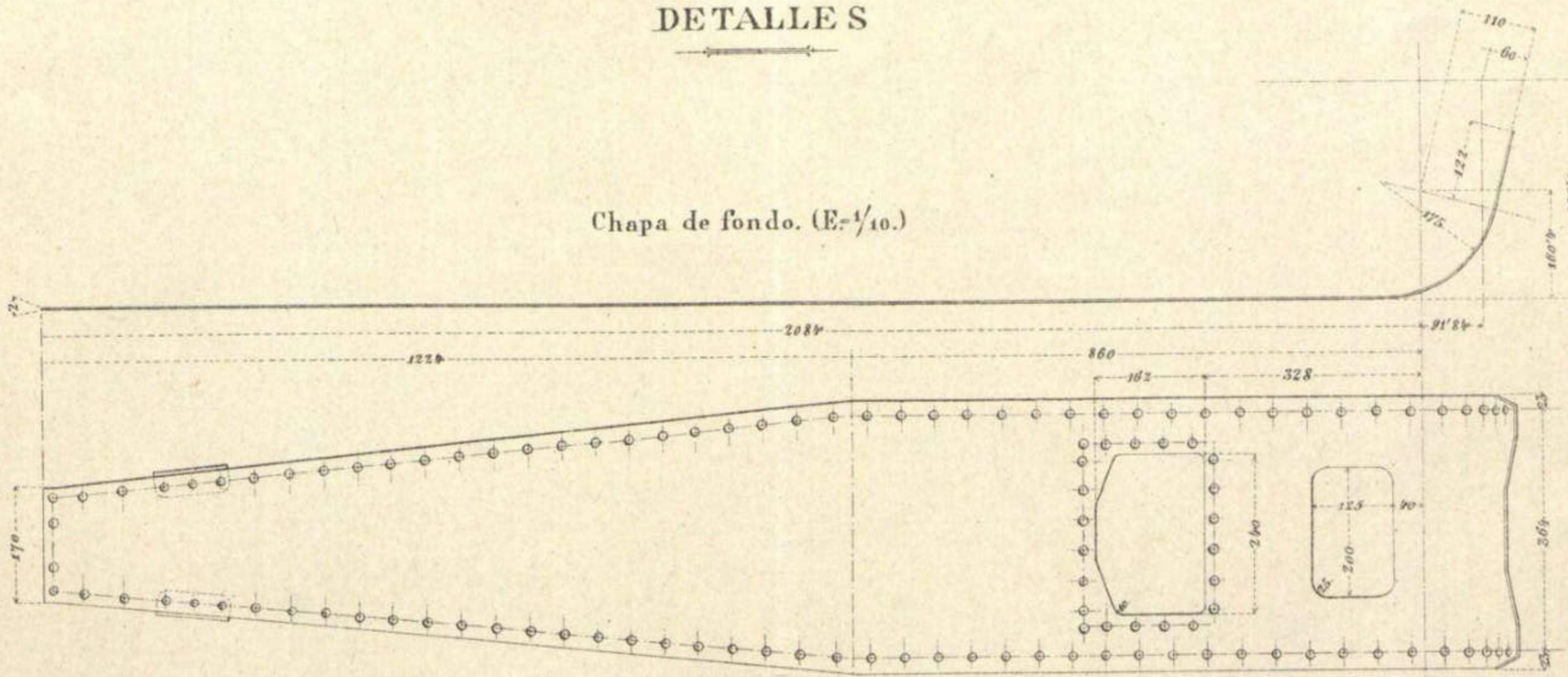

Caja de los sectores del mureo. (E.-2/10.)

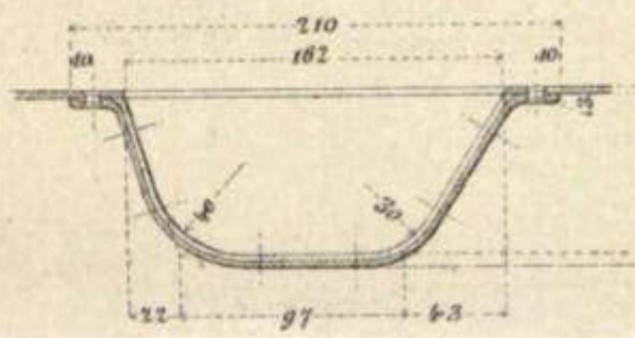

2 Rozaderos de ruedas. (E.-2/10.)

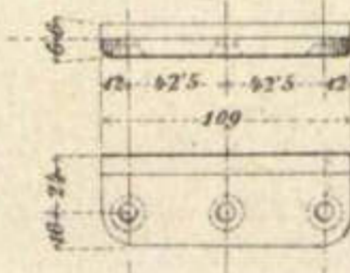

Refuerzos de ángulo. (E.-4/10.)

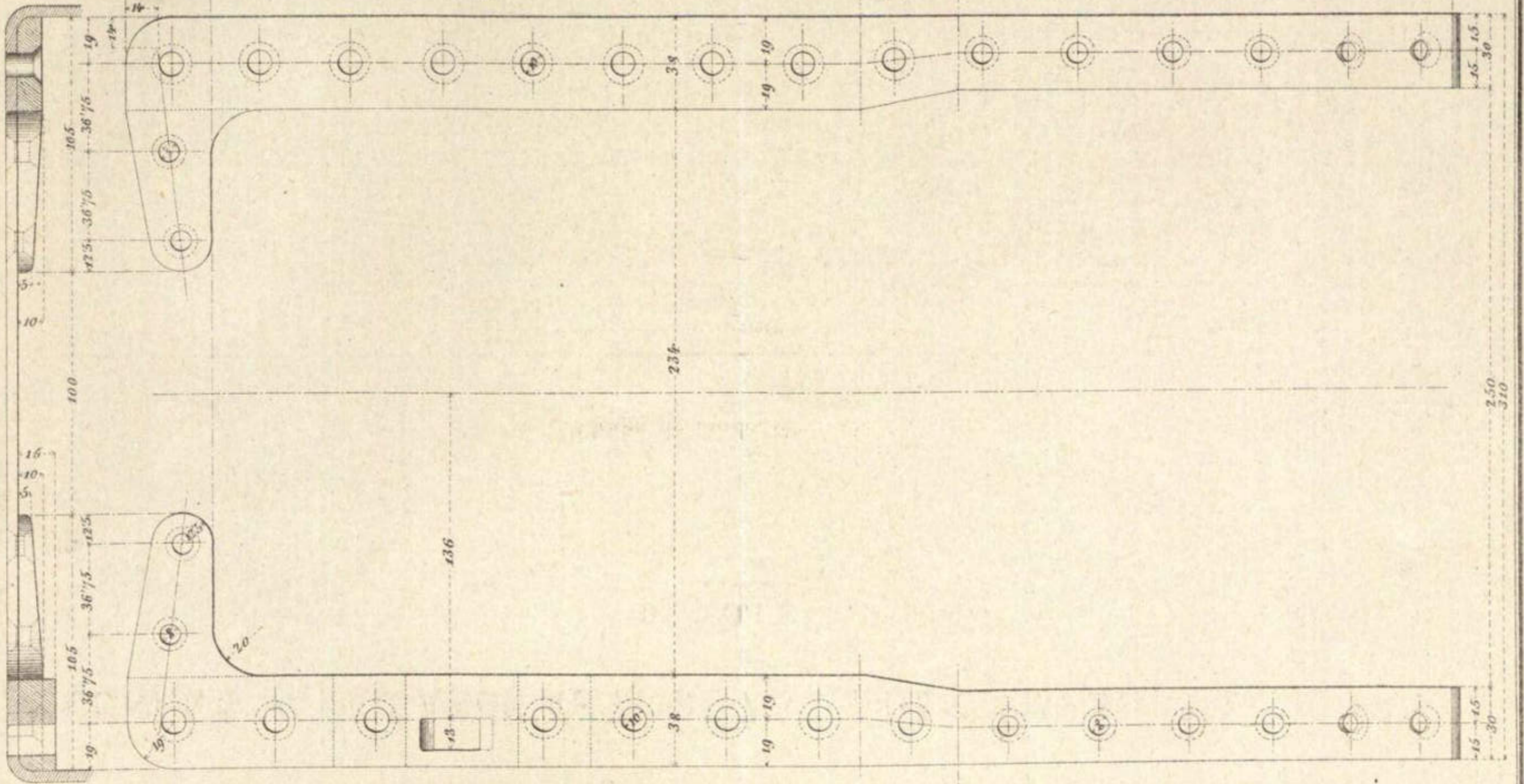
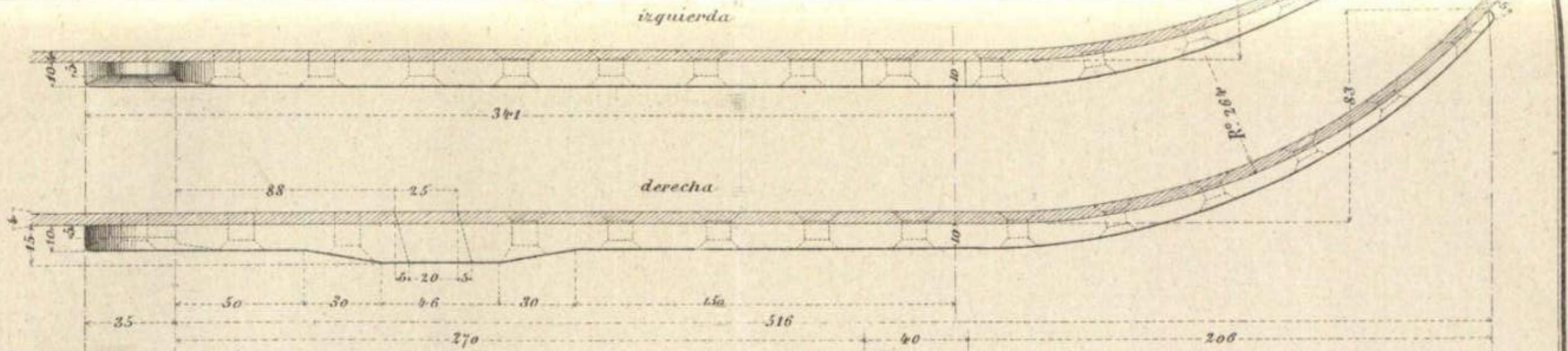

CUREÑA PARA CAÑON Ac. T. r. DE 7'5 cm. DE CAMPAÑA Md. 1906.

DETALLES.

Escala 2/10

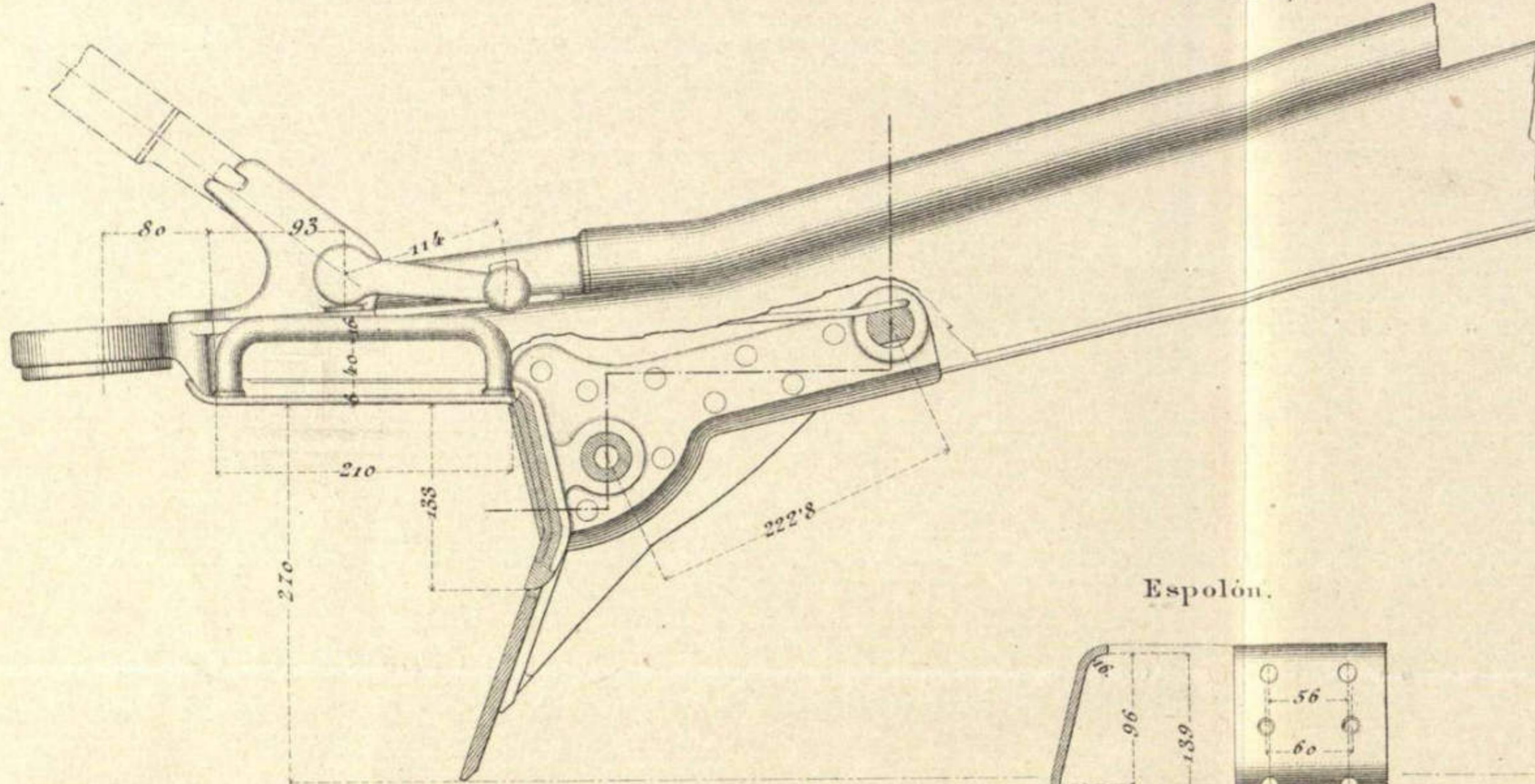

Espolón.

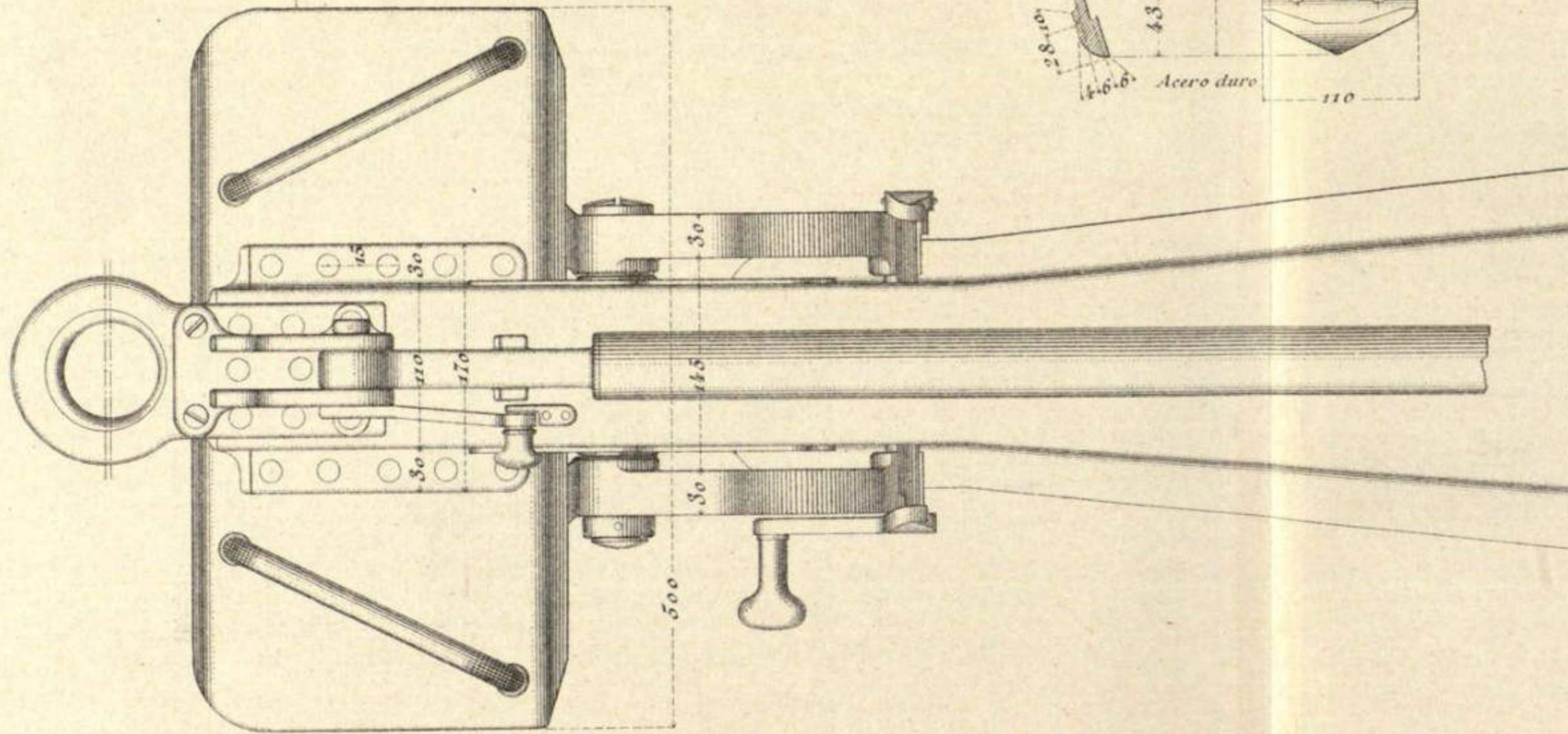
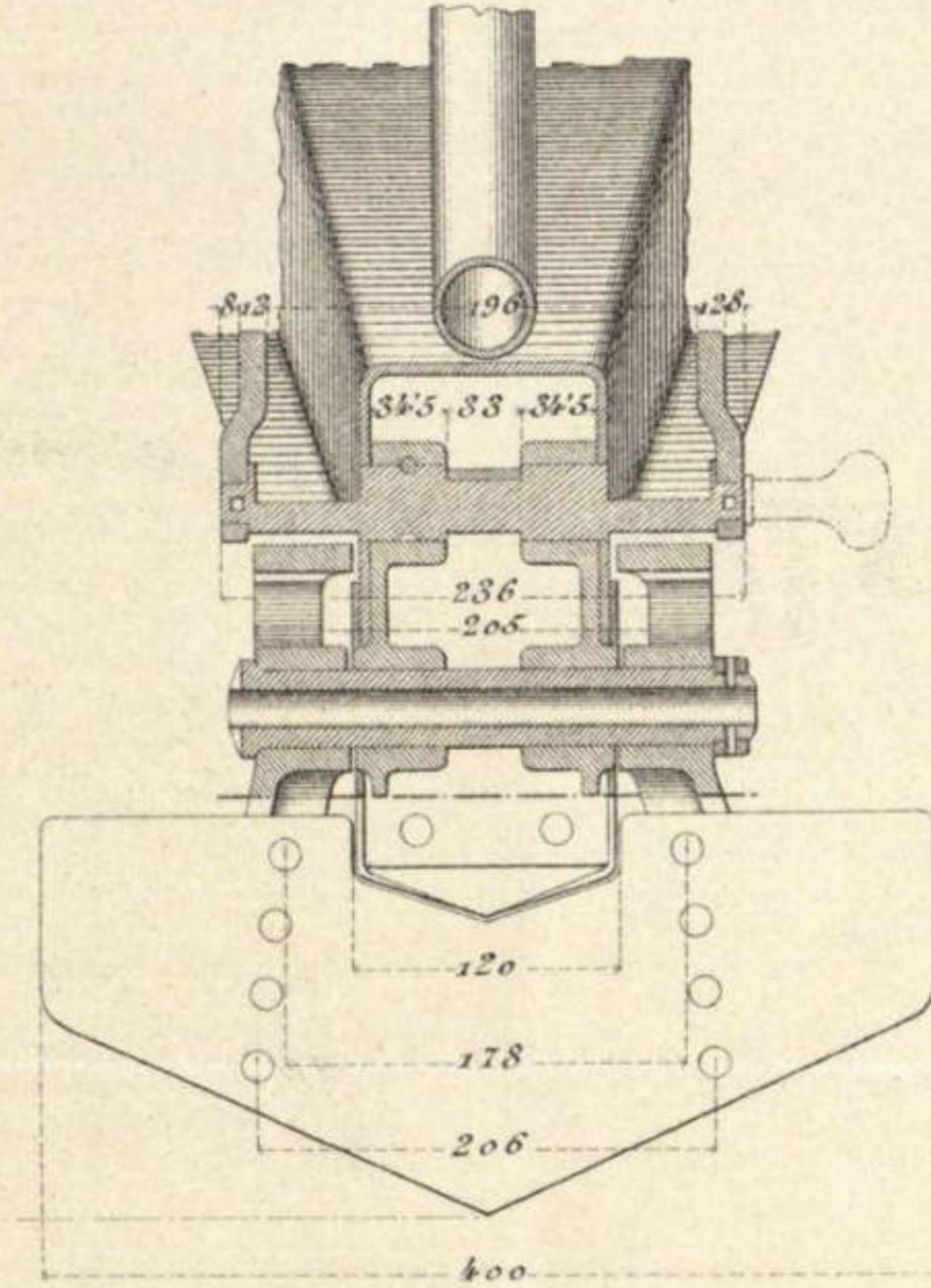
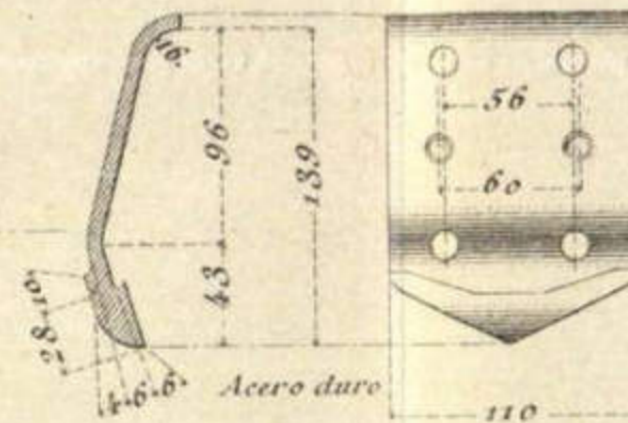

Cojinete del arado.(izquierda)

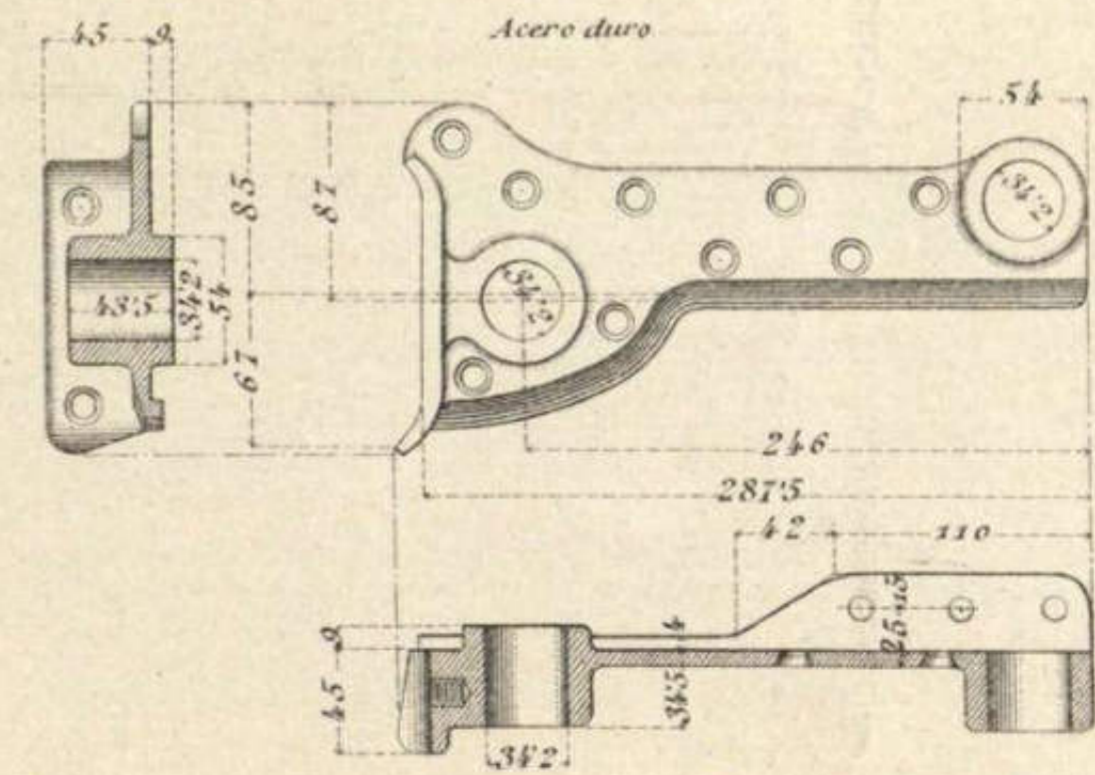

CUREÑA PARA CAÑÓN Ac. T. r. DE 7'5 cm. DE CAMPAÑA Md. 1906. DETALLES DEL ARADO

Escala 5/10.

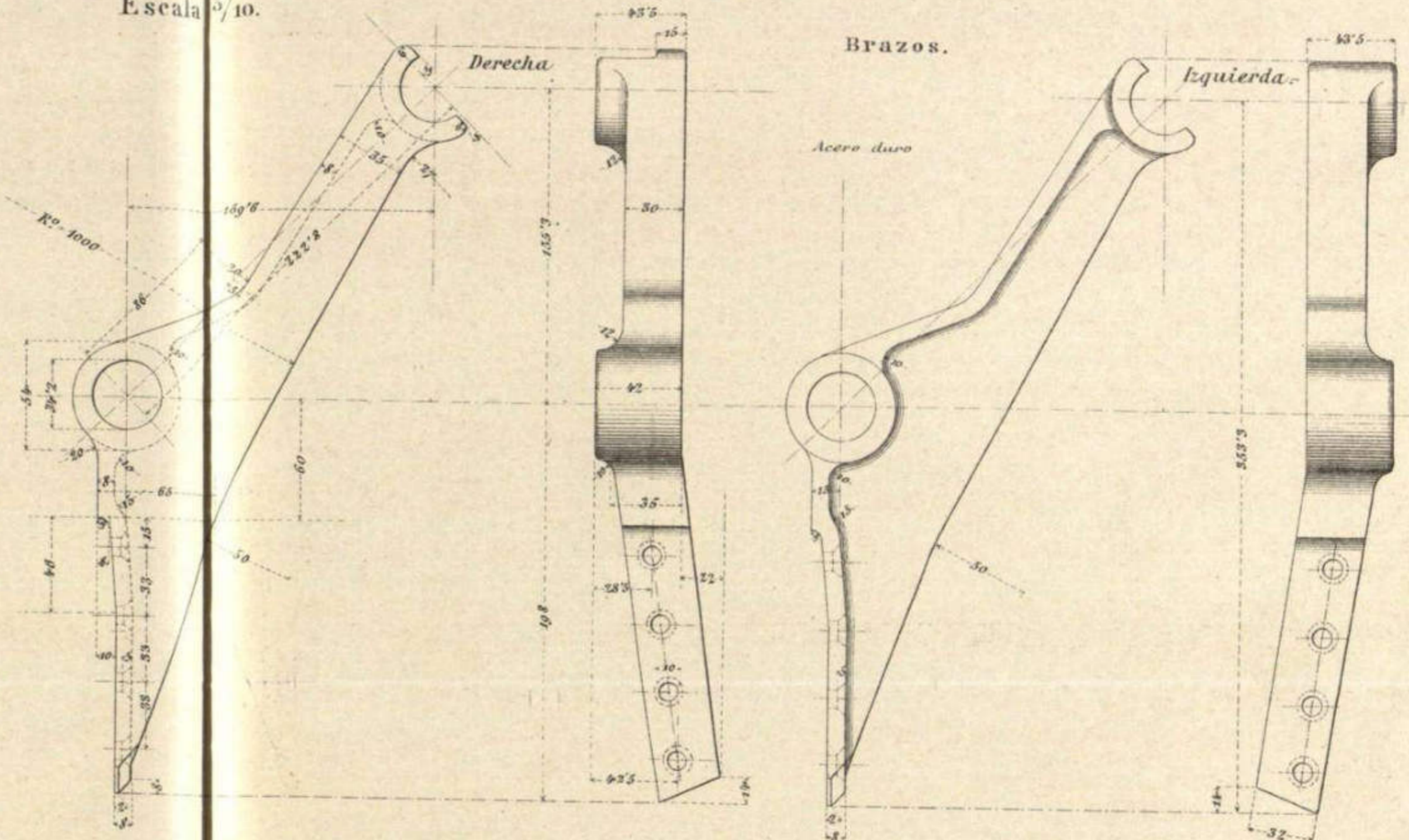
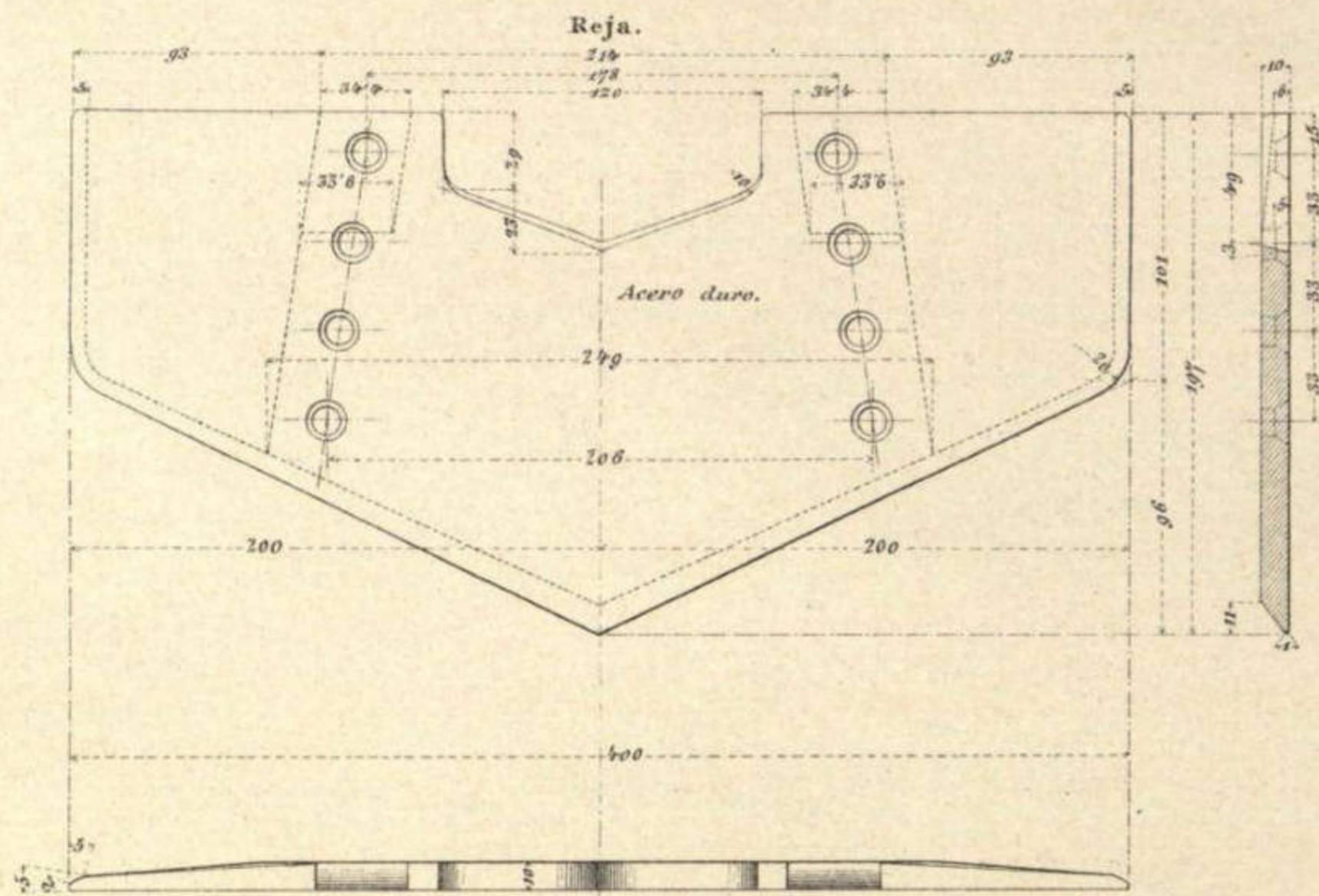

Escala 4/10.

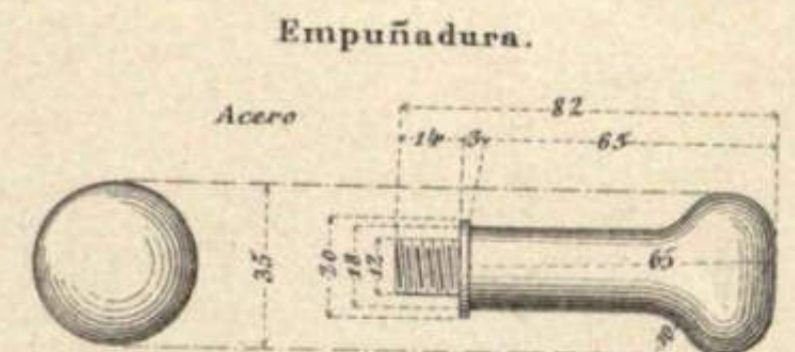
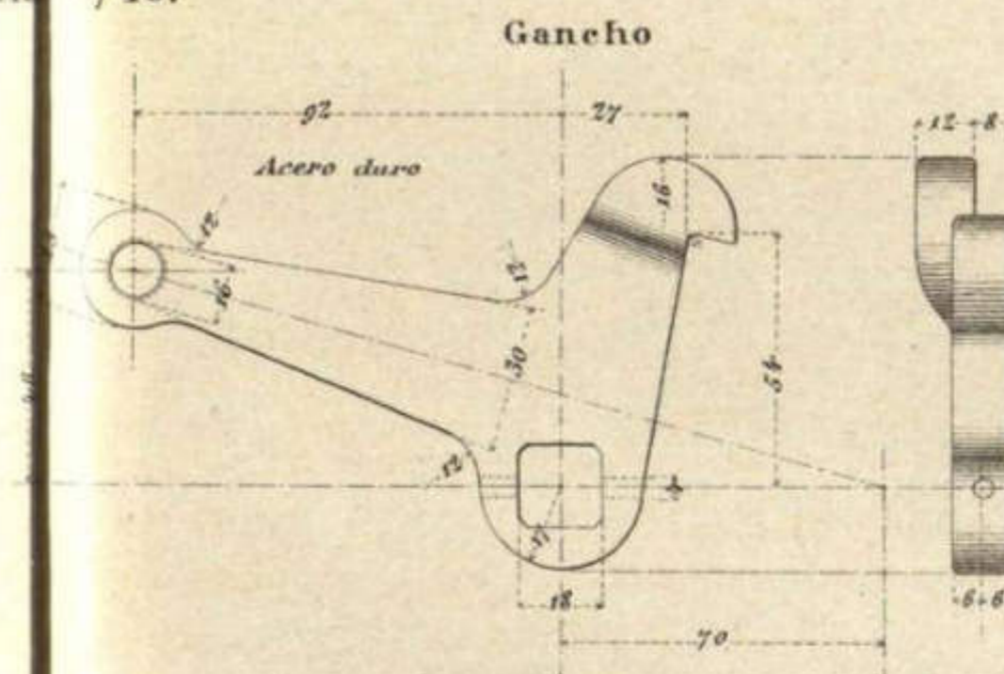
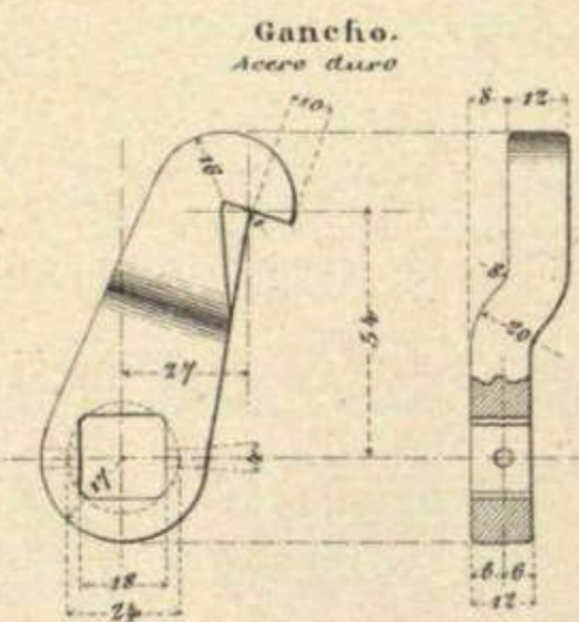
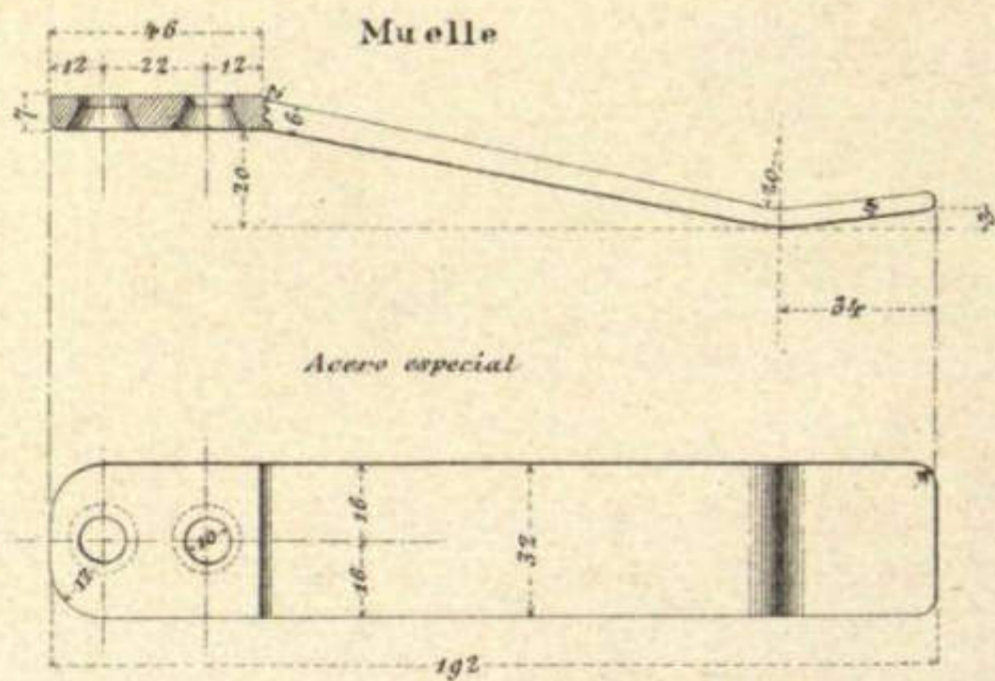

Cerrojo del arado.
Acero duro

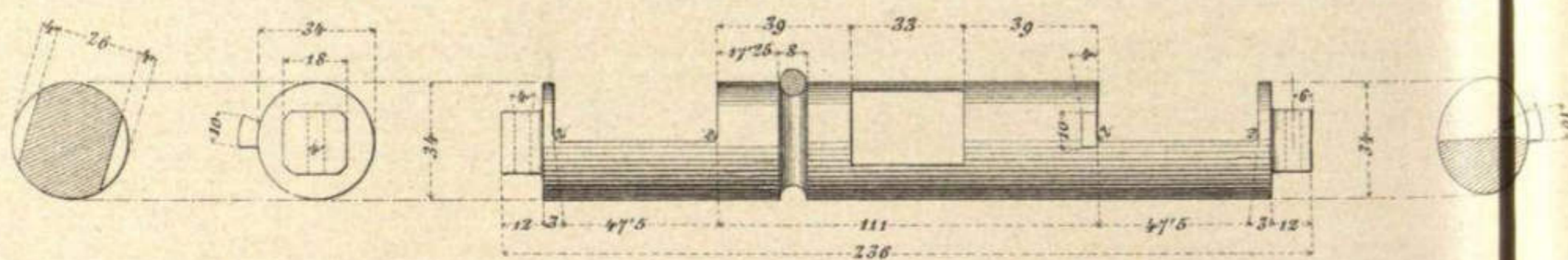

CUREÑA PARA CAÑON Ac. T. r. DE 7'5 cm. DE CAMPAÑA Md. 1906.

APARATO DISPARADOR.

Placa protectora (E. 5/10)

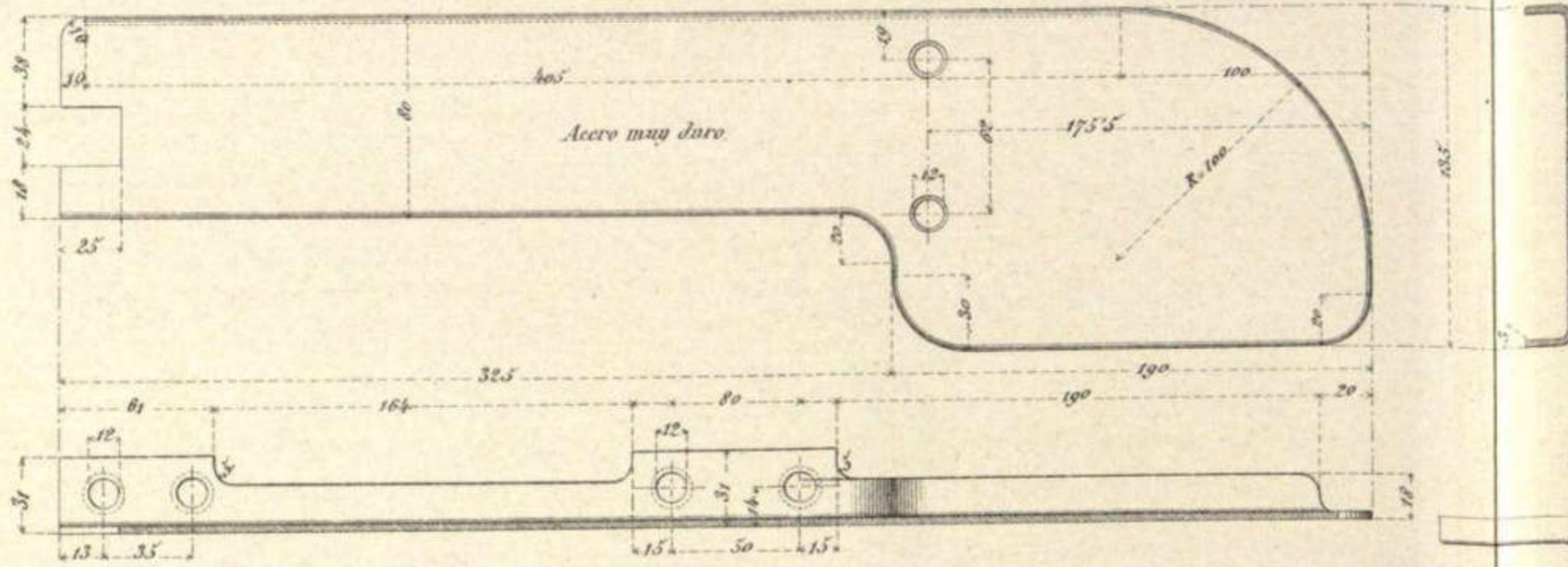

Tubo-cojinete.

Escala 5/10.

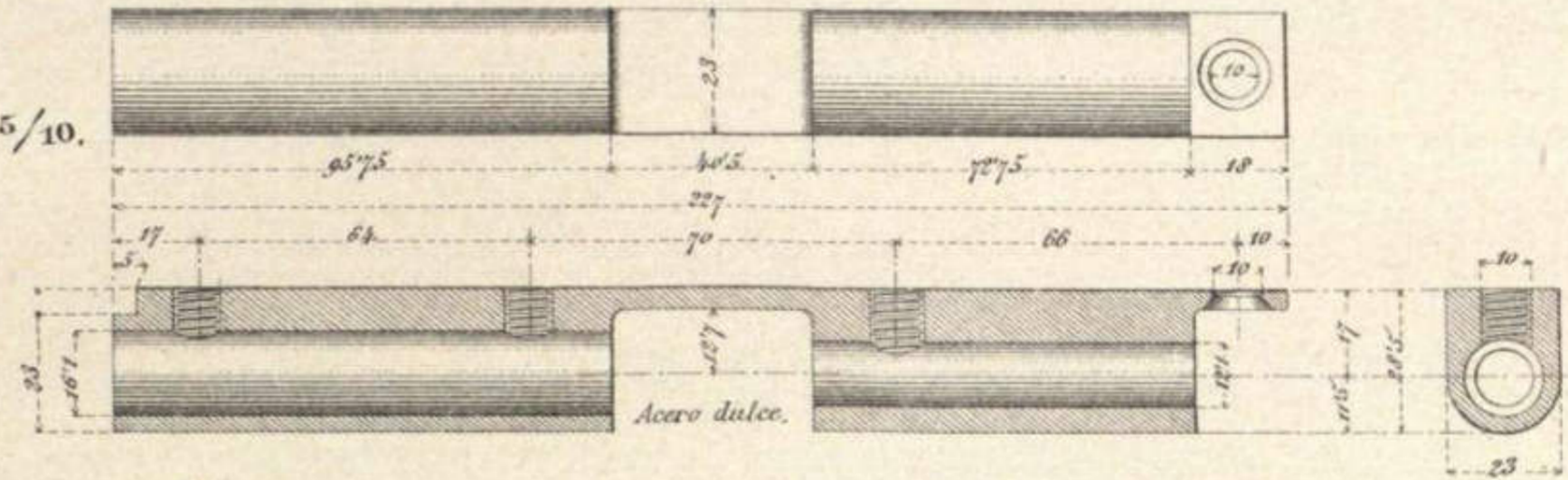

Tope del muelle.

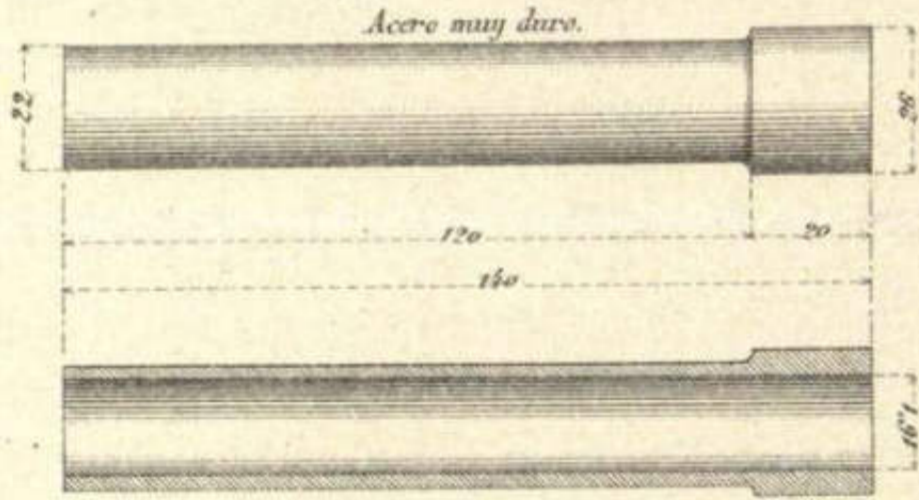

Collar

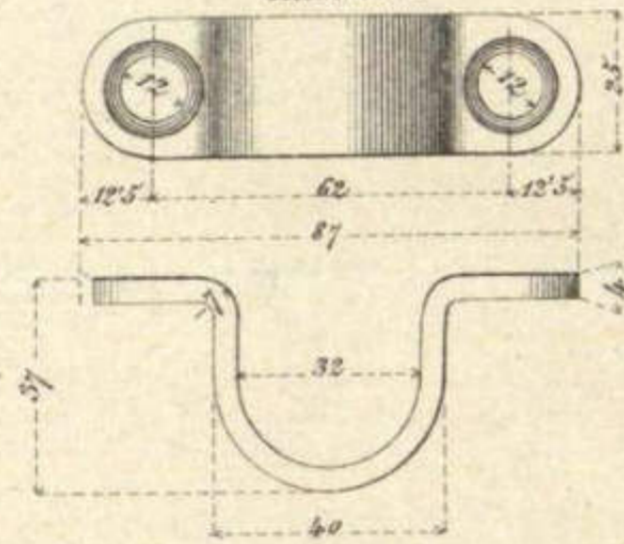

Muelle del botador.



Libre 4.55

| | |
|-----------------------|------|
| Número de espiras | 80 |
| Flecha inicial | 131 |
| Carga correspondiente | 28.5 |
| Flecha final | 251 |
| Carga correspondiente | 4.8 |

Soporte de los órganos del disparador.

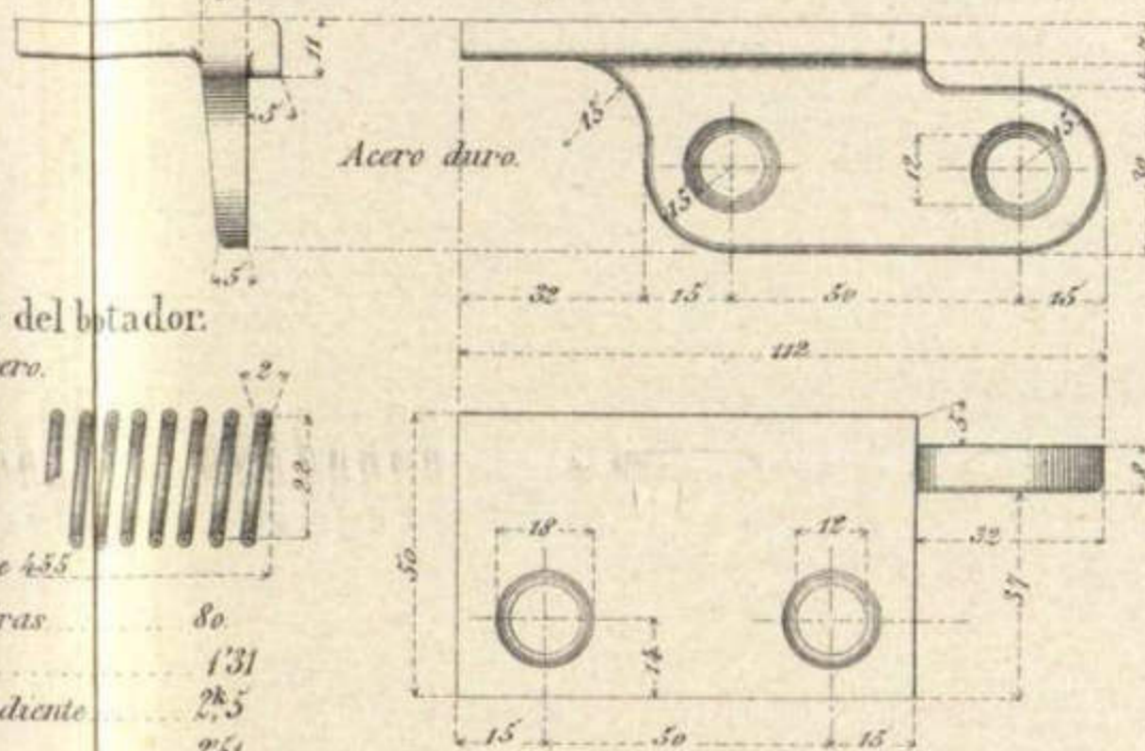

Corredera.

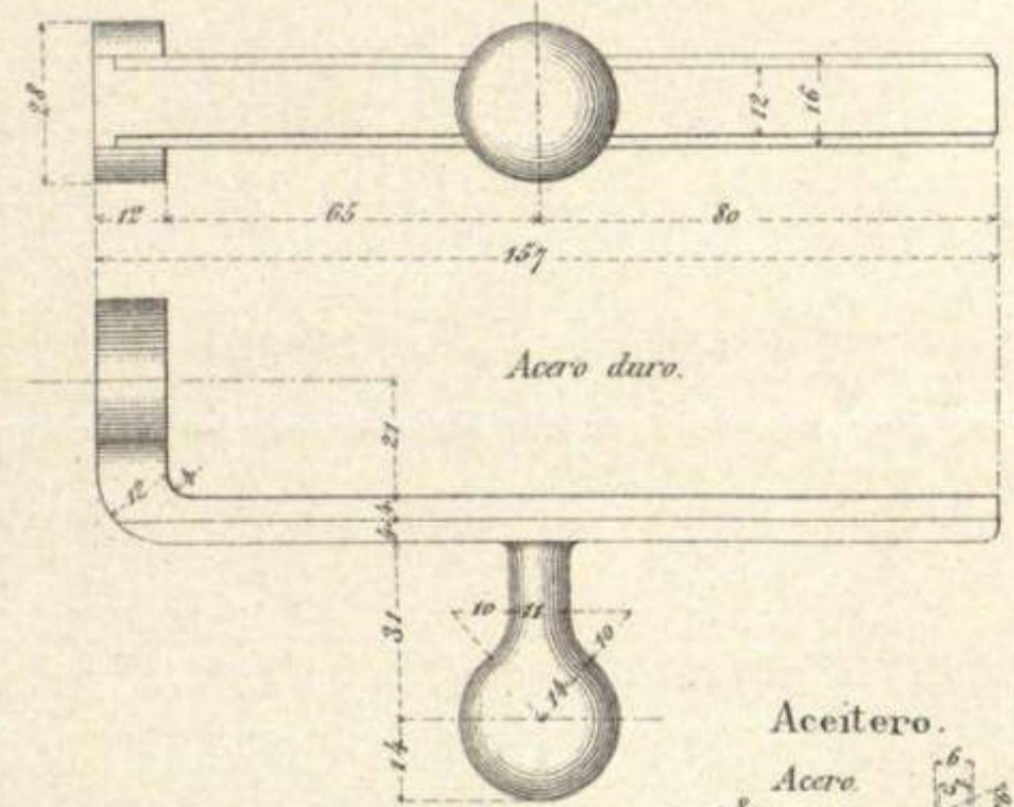

Soporte de los órganos del disparador.

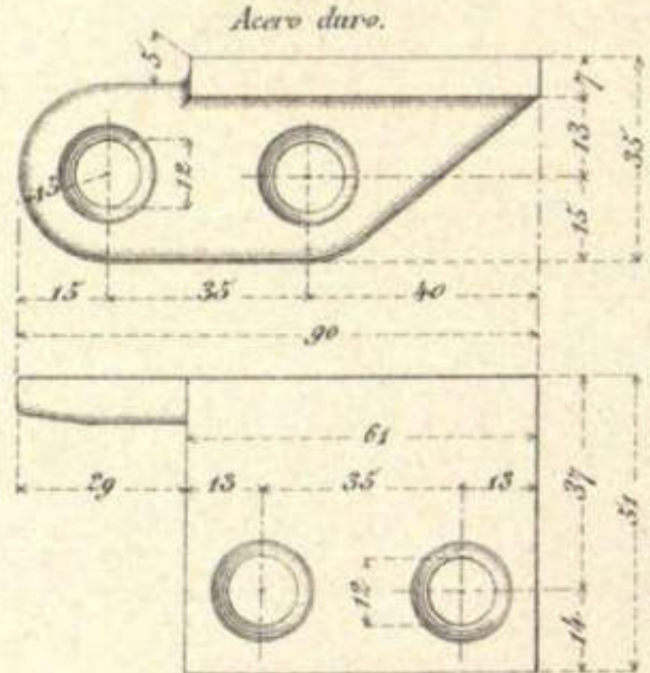

Tubo-guía.

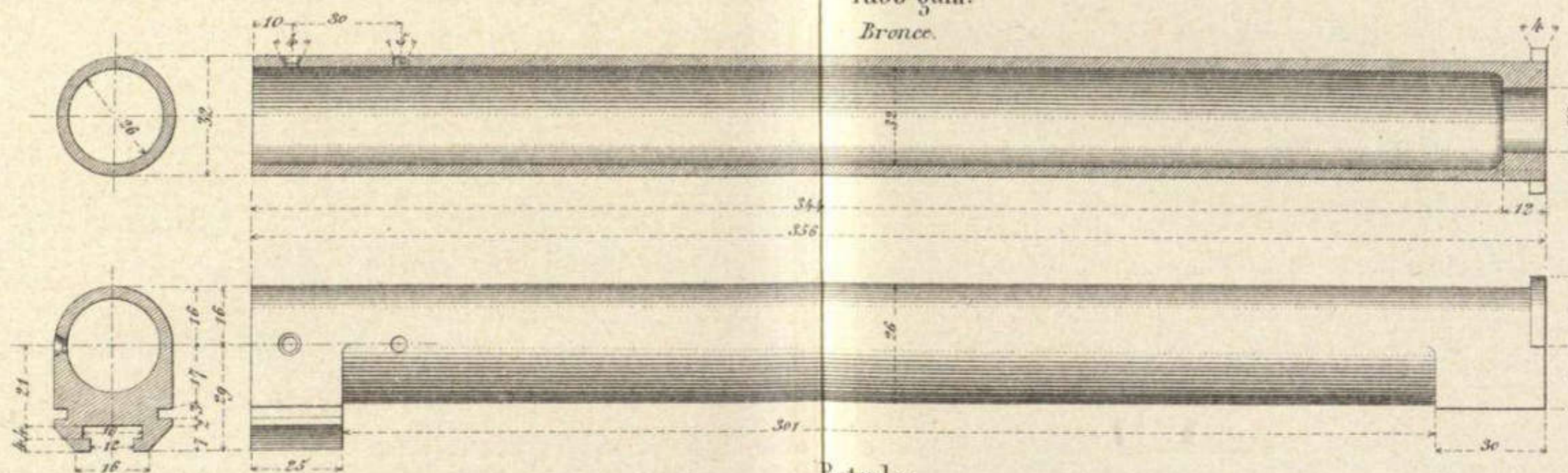

Aceitero.

Arandela.

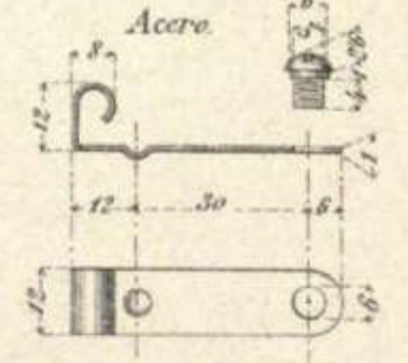
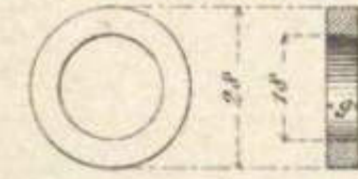

Talón del botador.

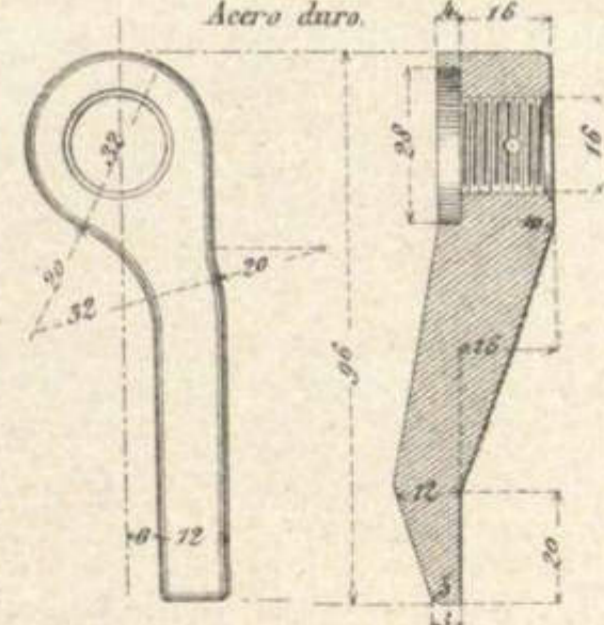

Botador.

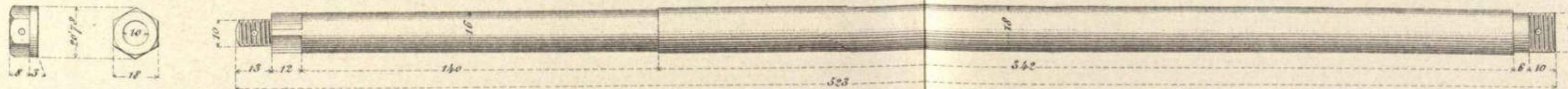

CUREÑA PARA CAÑON Ac. T. r. DE 7'5 cm. DE CAMPAÑA Md. 1906

DETALLES DEL FRENO DE MARCHA

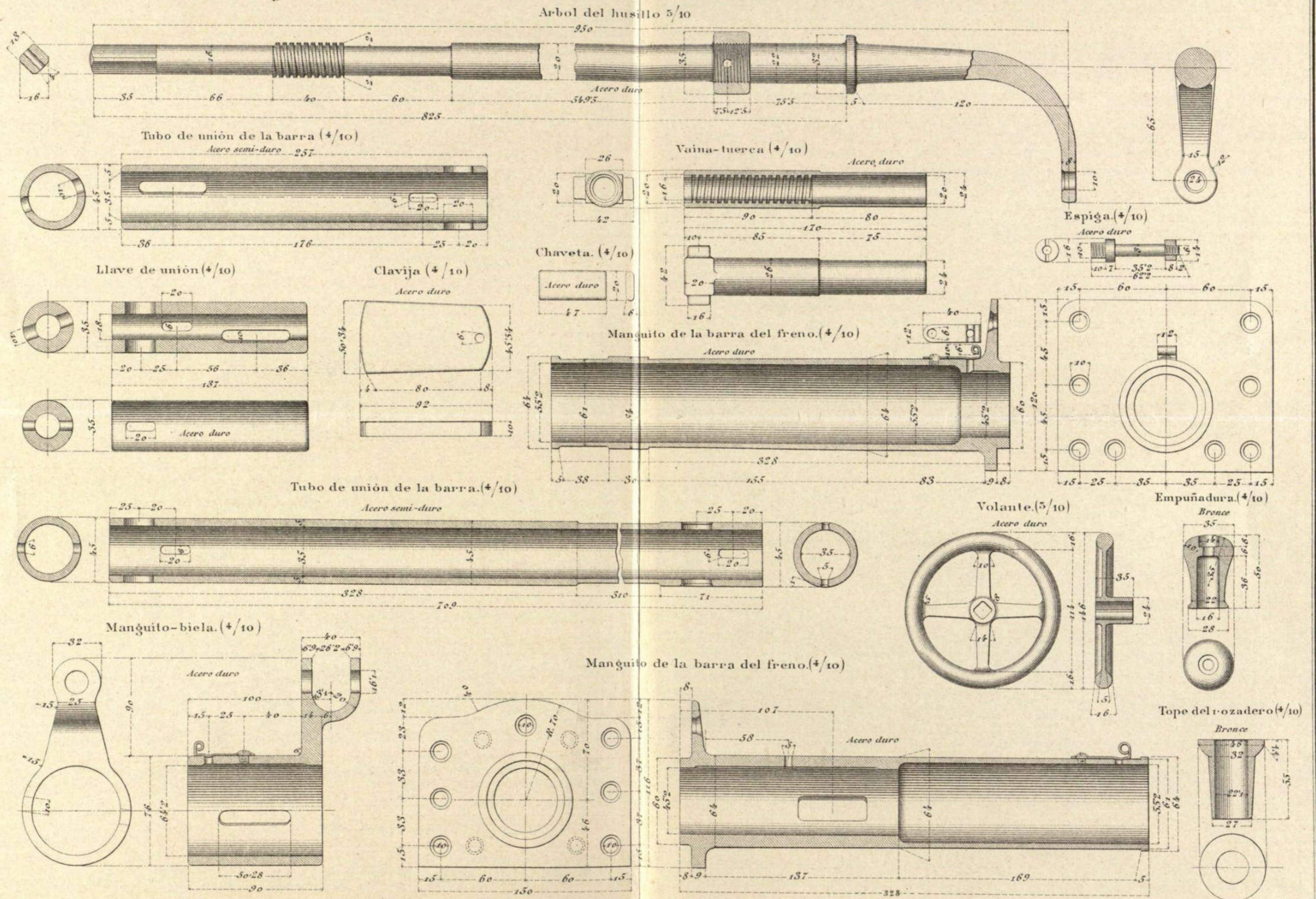

CUREÑA PARA CAÑÓN Ac. T. r. DE 7'5 cm. DE CAMPAÑA Md. 1906. DETALLES DEL FRENO DE MARCHA.

Escala 1/10.

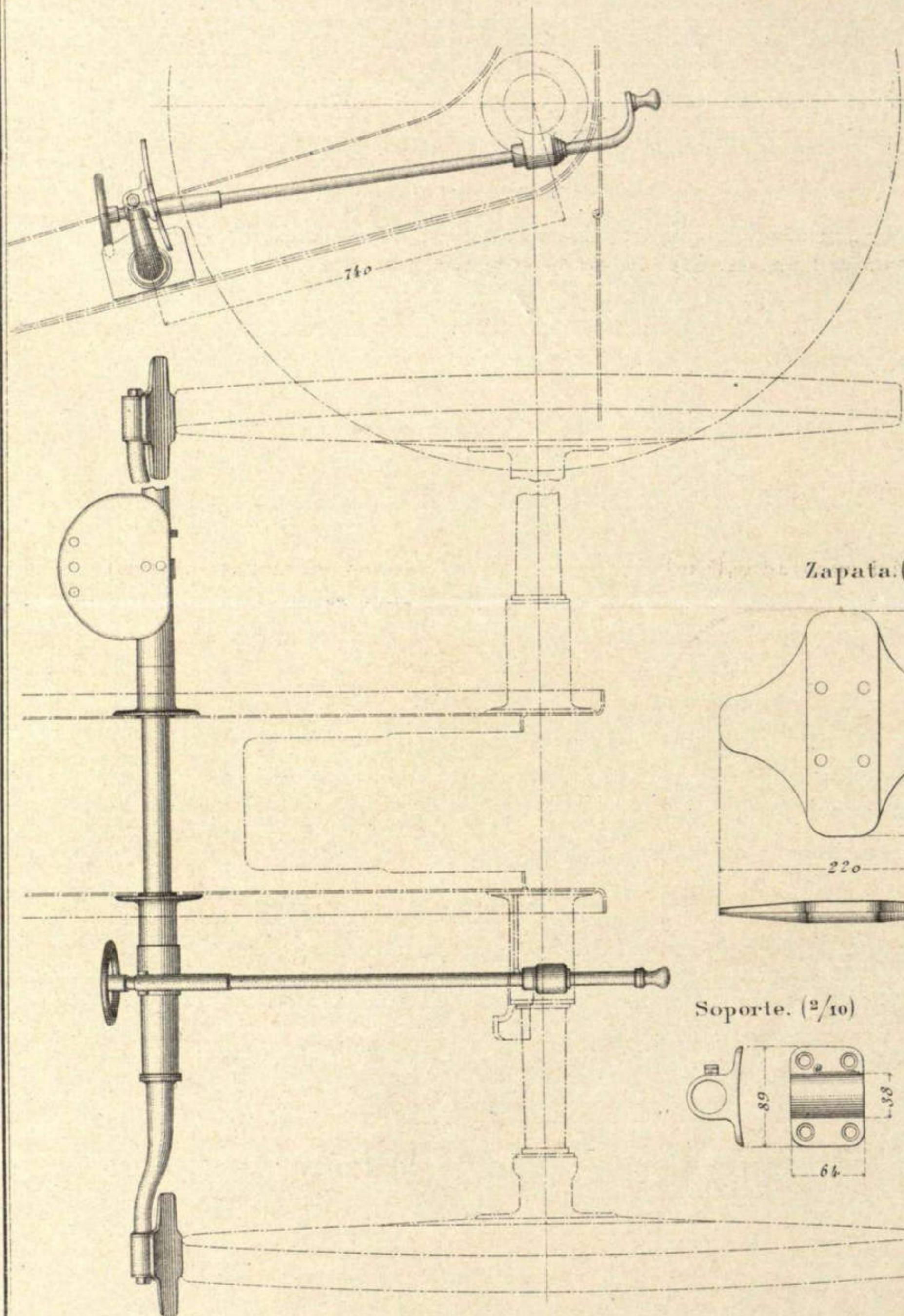

Zapata. (2/10)

Asiento del apuntador. (5/10)

Soporte del asiento (5/10)

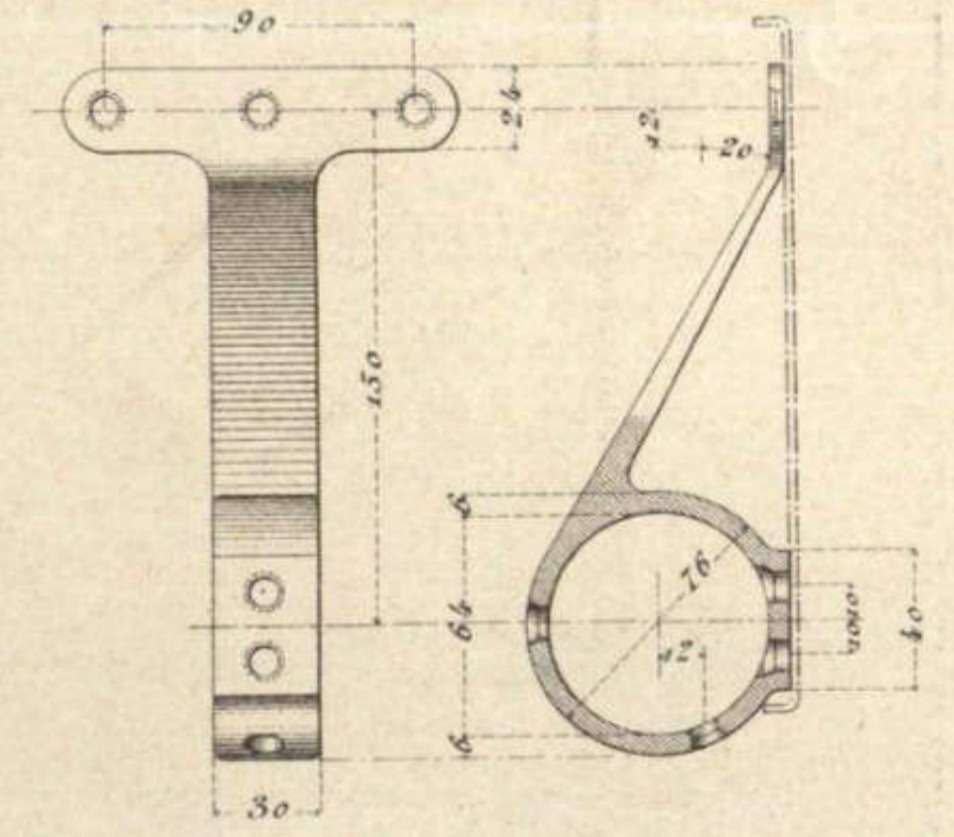
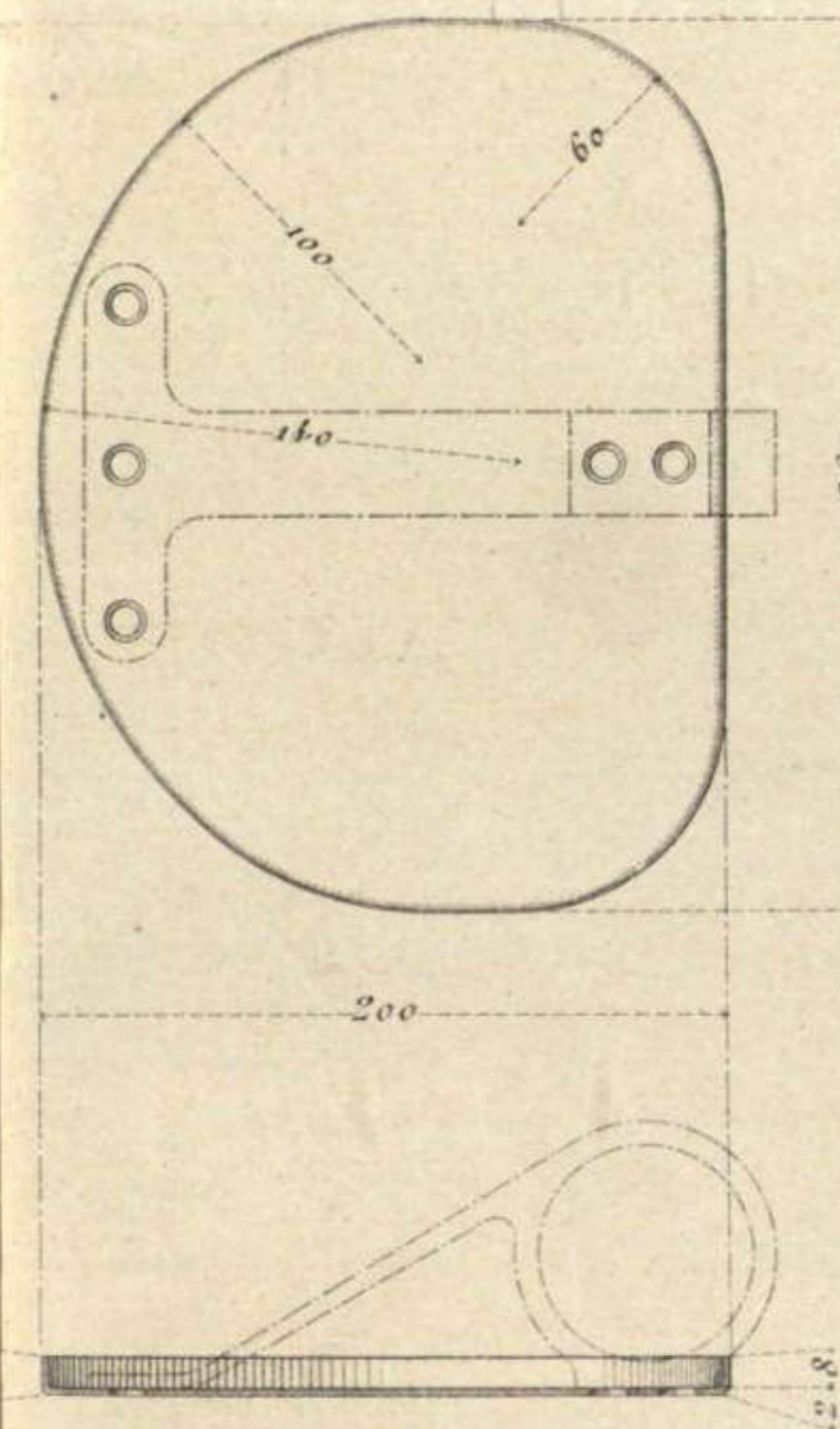
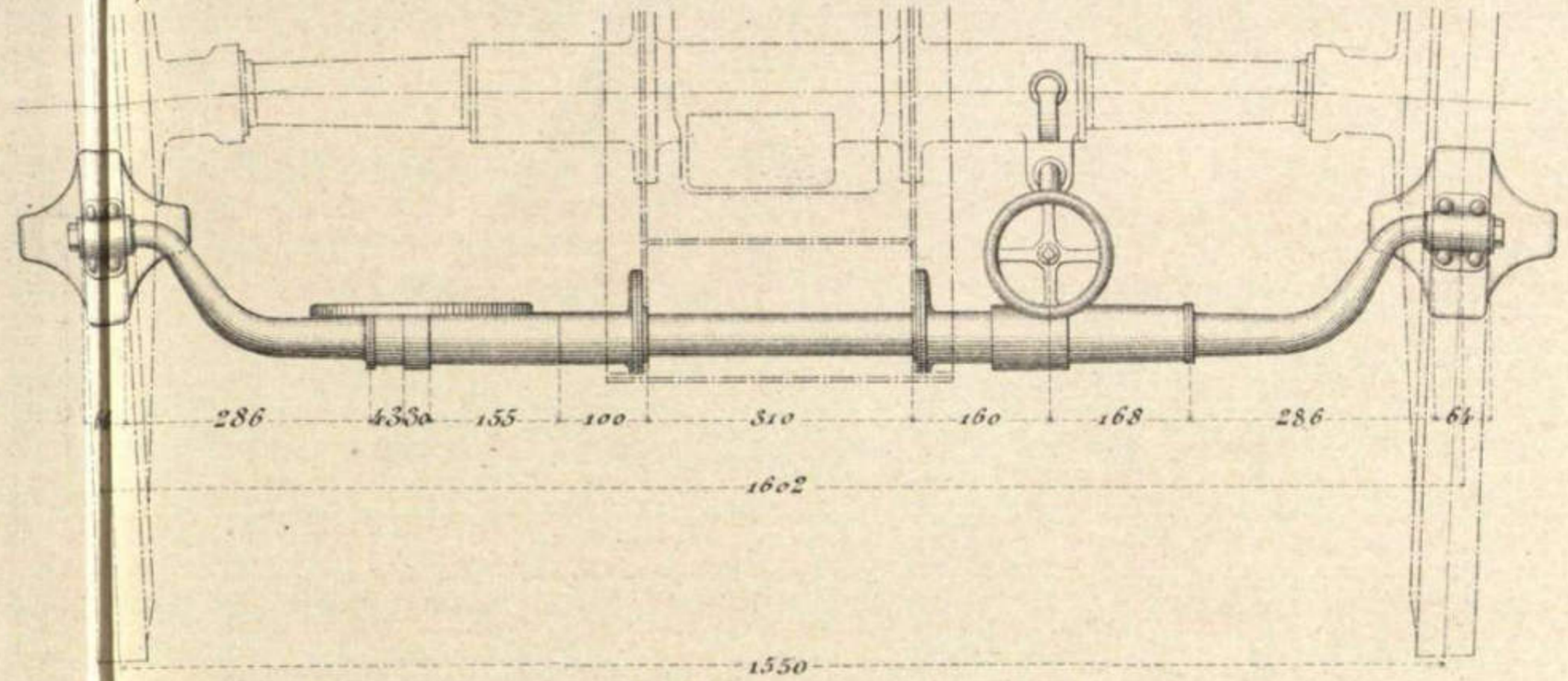

2 Brazos de las zapatas. (2/10)

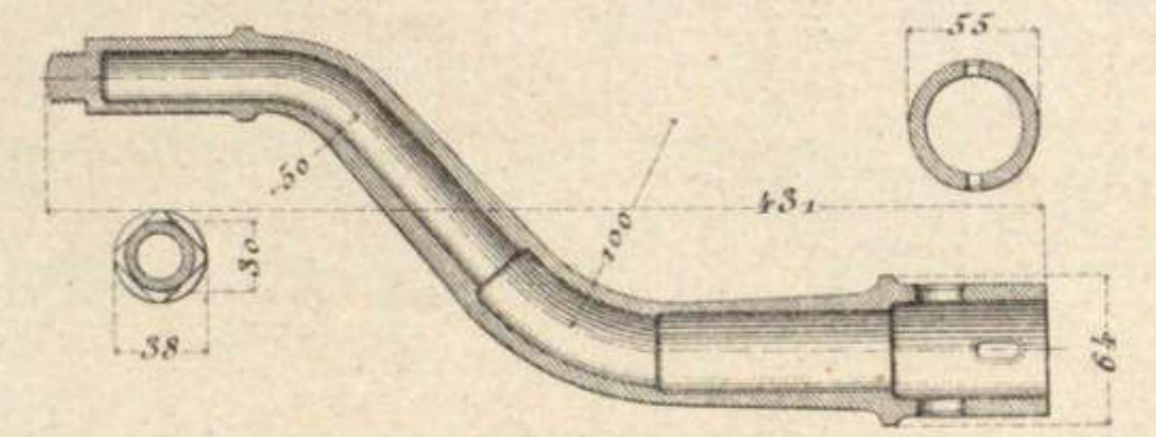

CUREÑA PARA CAÑÓN Ac. T. r. DE 7' 5 cm. DE CAMPAÑA Md. 1906.

DETALLES

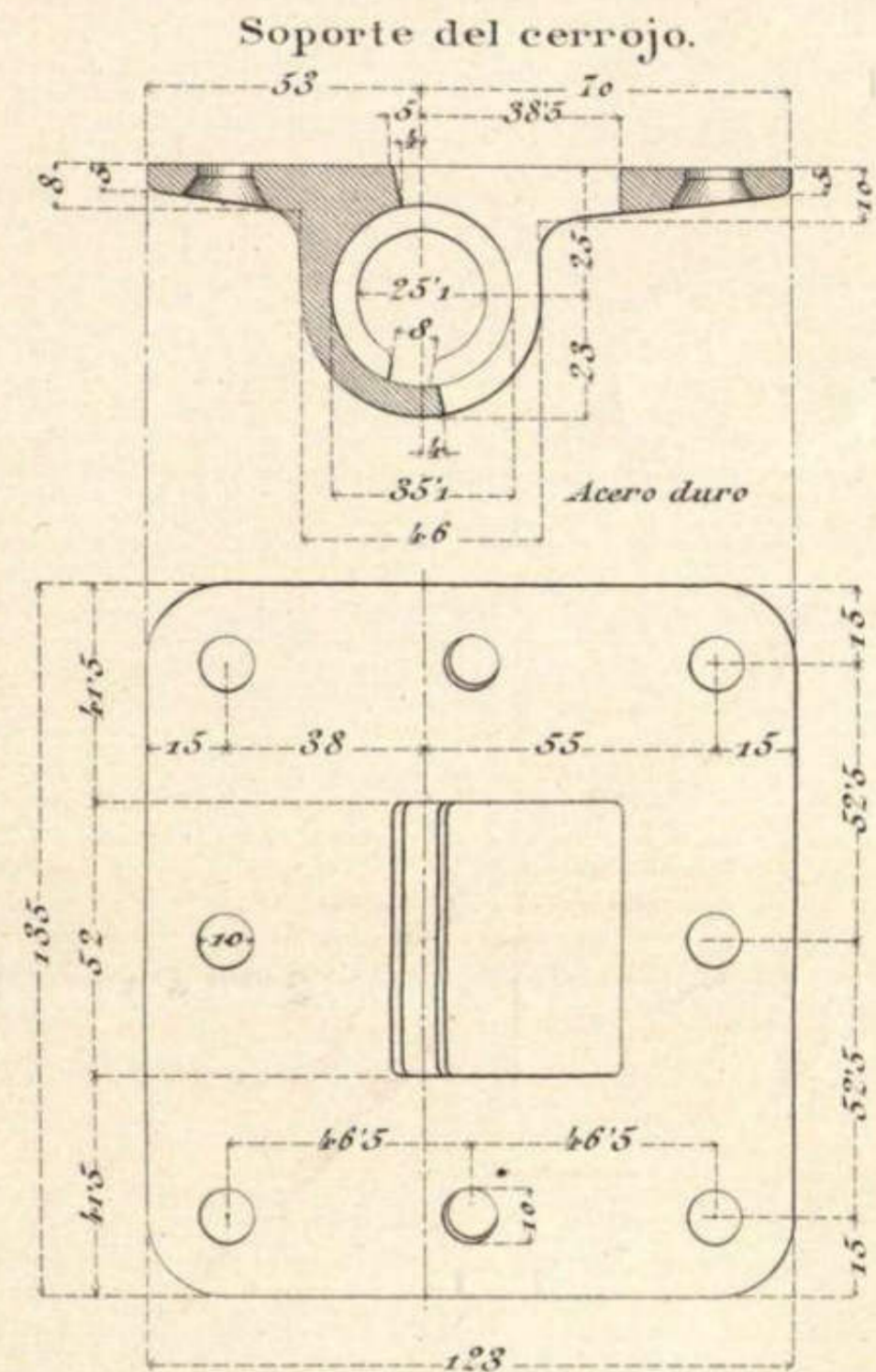
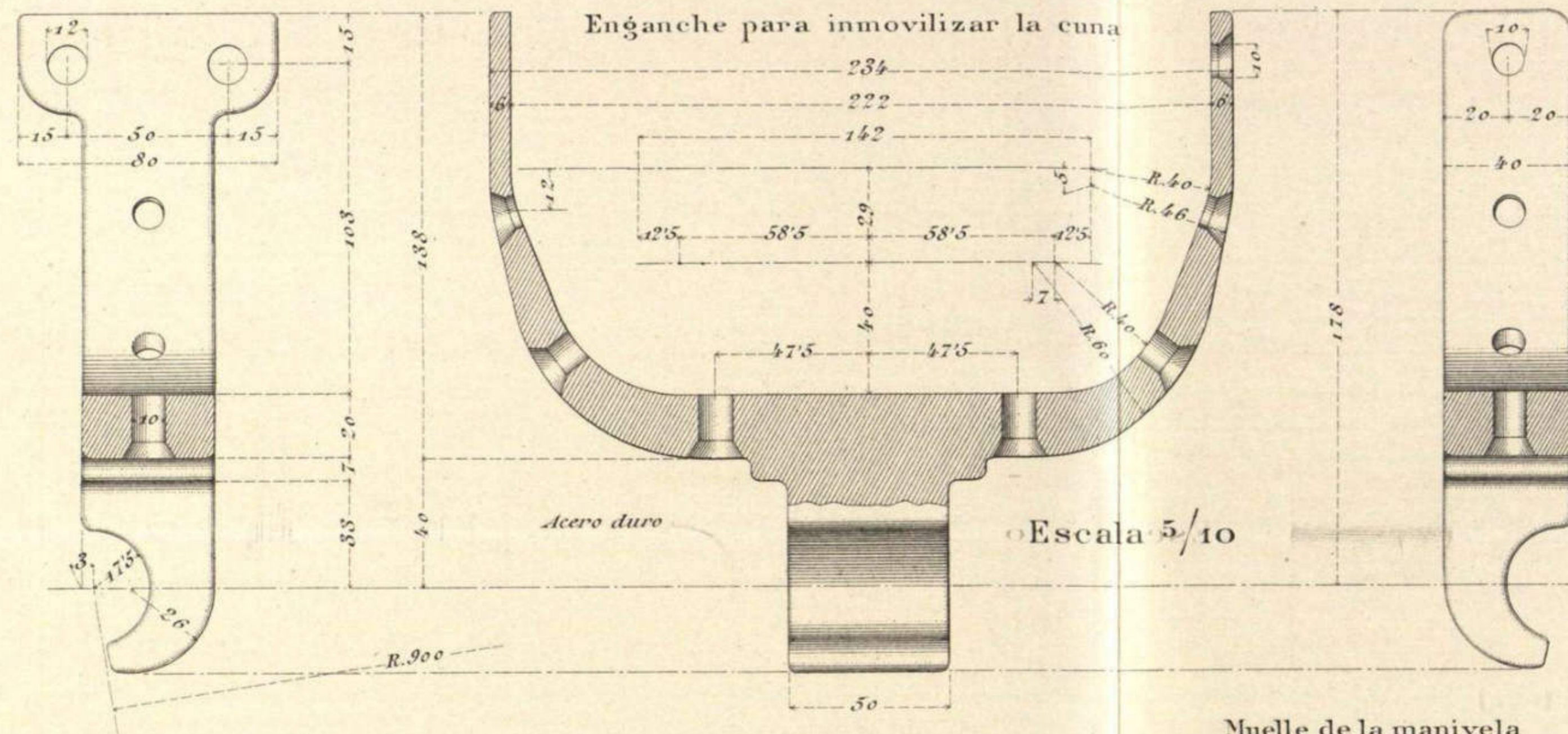

Vaina de la manivela

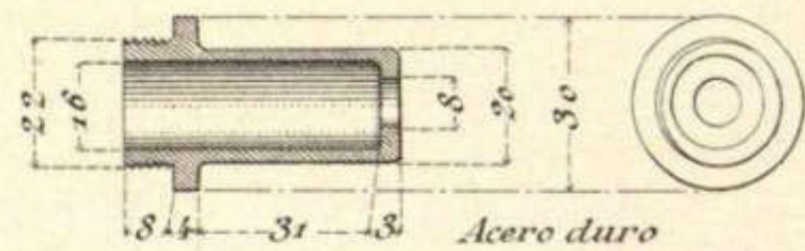

Espiga de la manivela

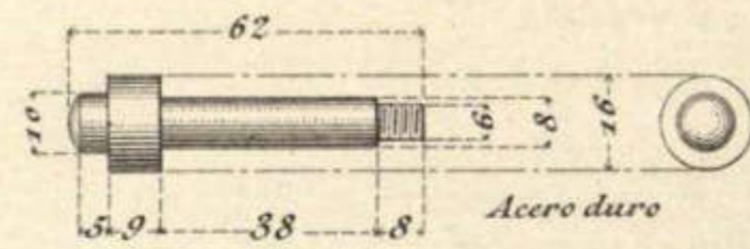

Muelle de la manivela

Acero especial

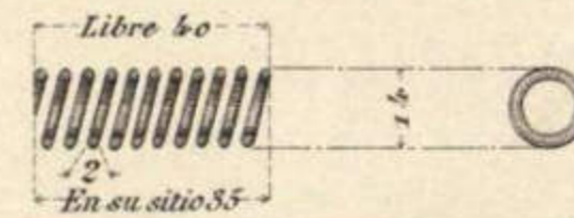

Carga inicial..... 4 à 5 K.
 id. con el cerrojo sacado 10 "
 Número de espiras..... 10

Puño de la manivela

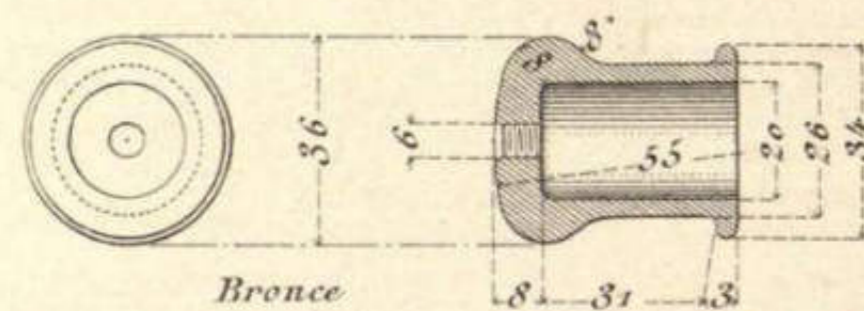

Boton-tope

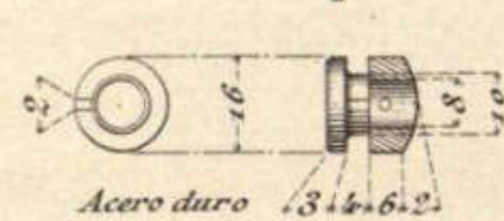

Eje del cerrojo

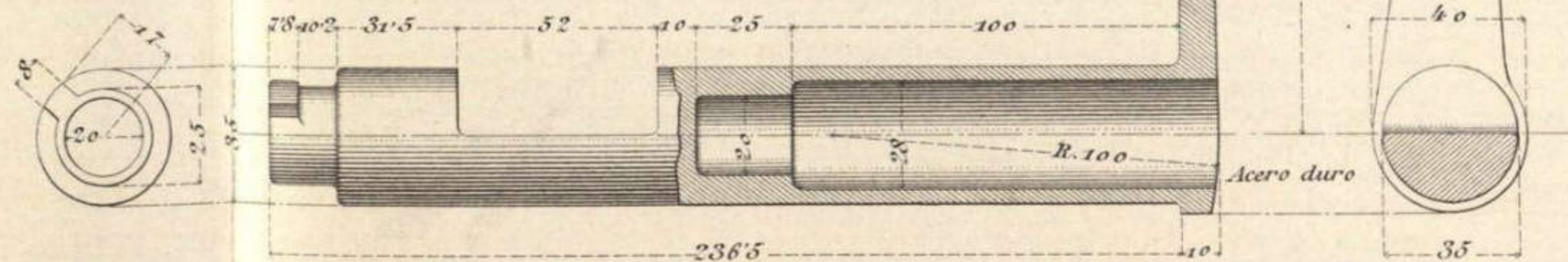

CUREÑA PARA CAÑON Ac. T. r. DE 7'5 cm. DE CAMPAÑA Md. 1906.

APARATO DE PUNTERIA EN ALTURA

DETALLES.

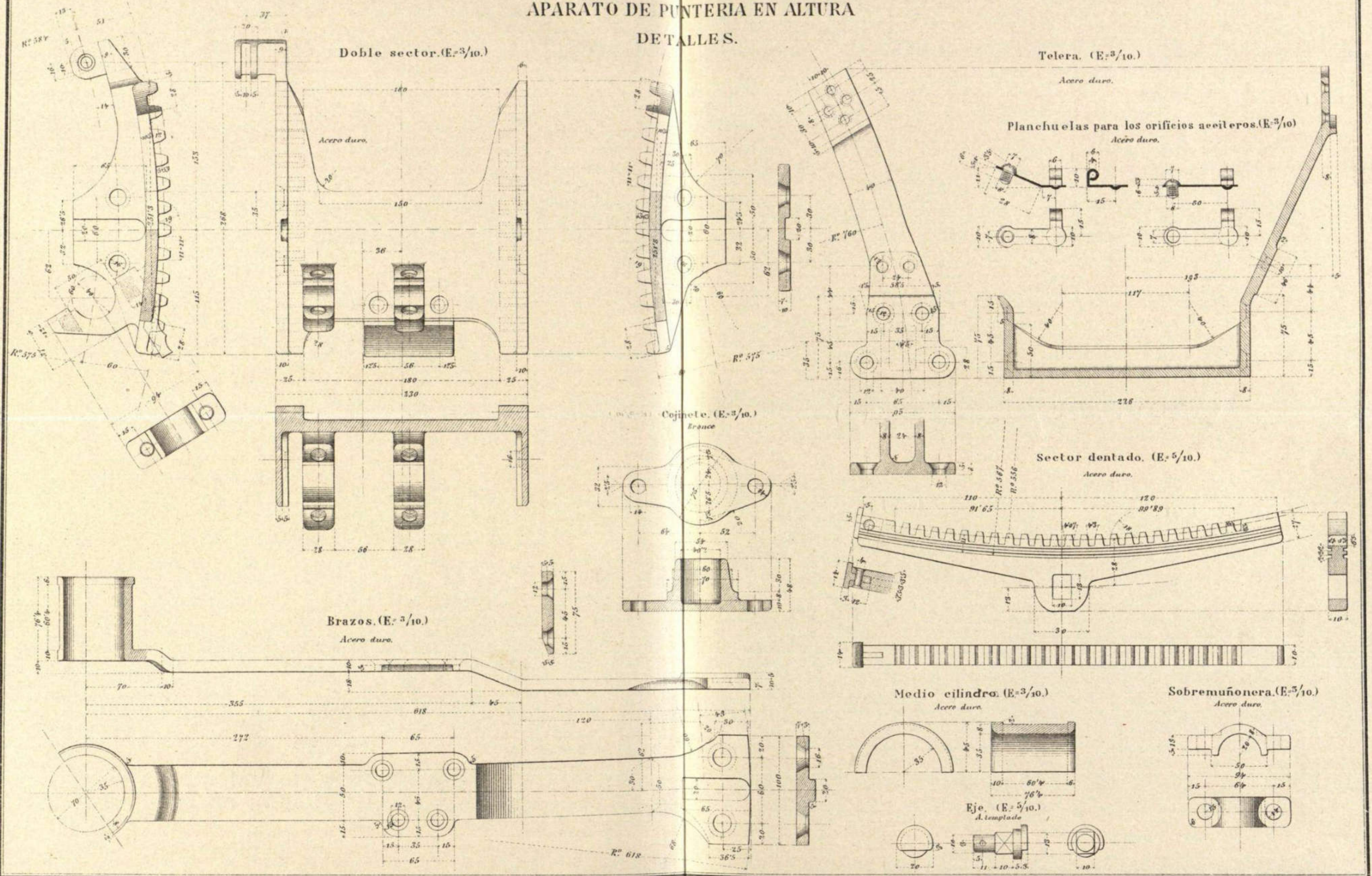

CUREÑA PARA CAÑÓN Ac. T. r. DE 7'5 cm. DE CAMPAÑA Md. 1906.

APARATO DE PUNTERIA EN ALTURA

DETALLES.

Escala $\frac{1}{10}$.

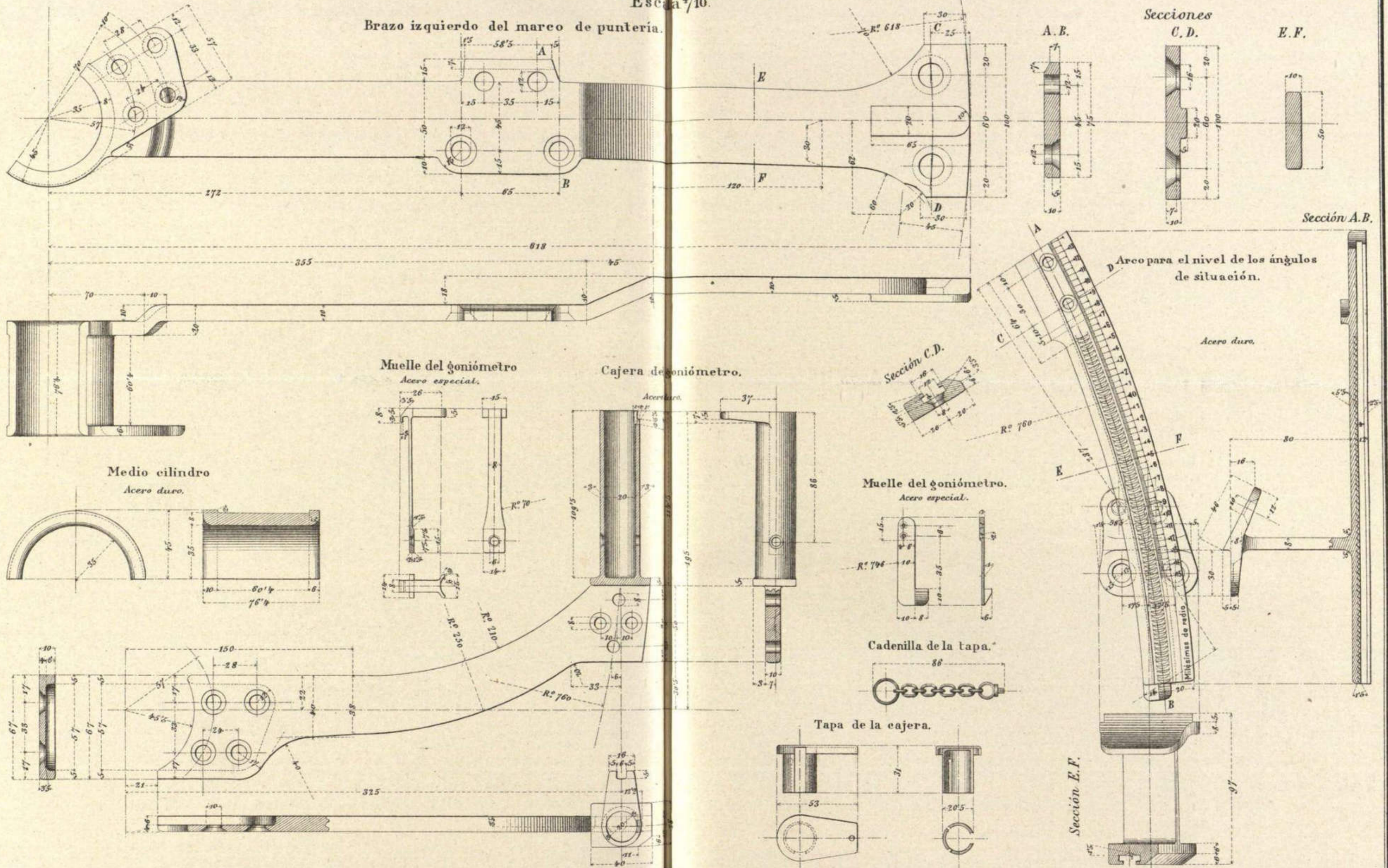

CUREÑA PARA CAÑÓN Ac. T. r. DE 7' 5 cm. DE CAMPAÑA Md. 1906.

APARATO DE PUNTERIA EN ALTURA

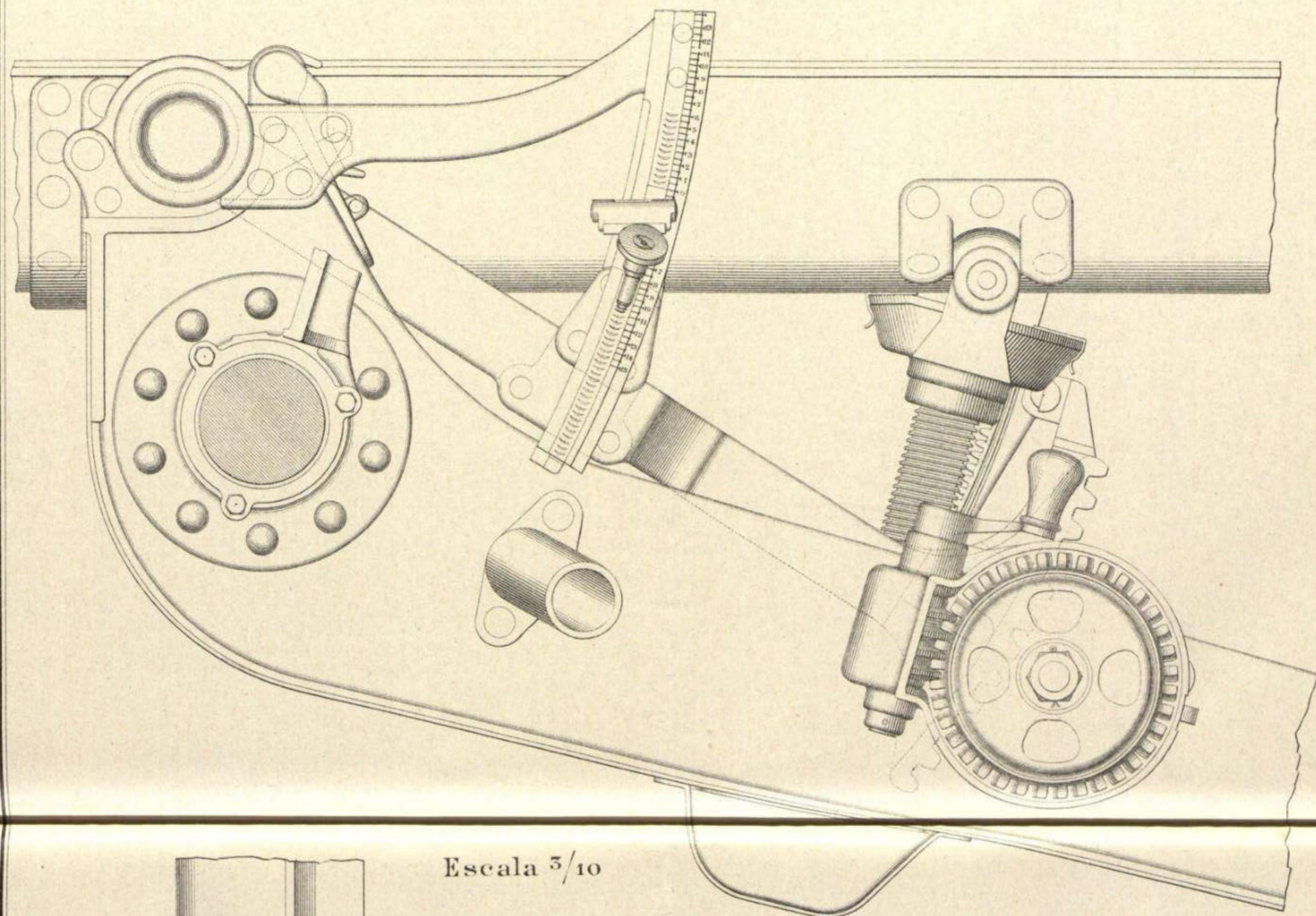

Escala 5/10

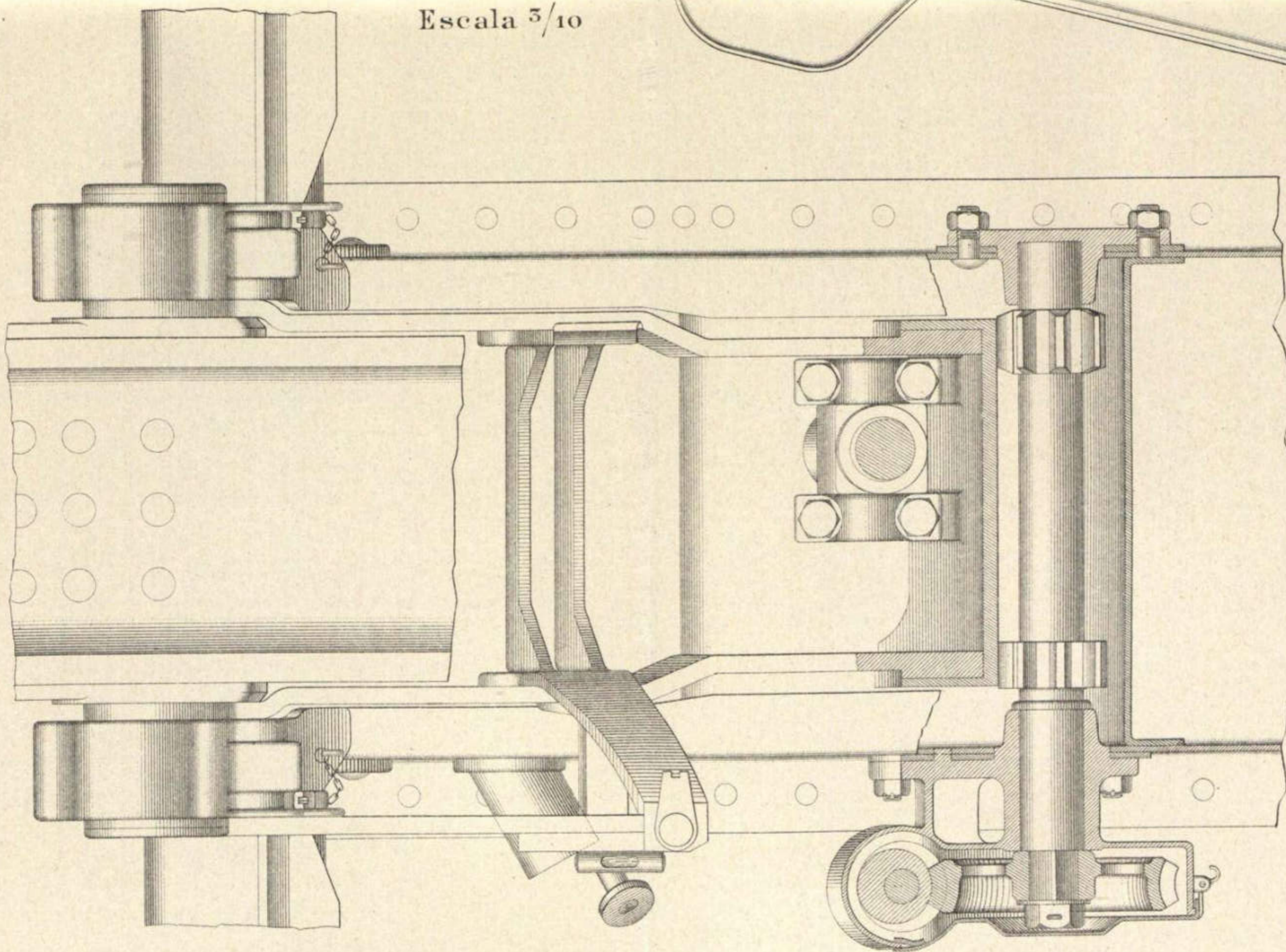

CUREÑA PARA CAÑON Ac. T. r. DE 7' 5 cm. DE CAMPAÑA Md. 1906.

APARATO DE DAR DIRECCION

Escala 5/10

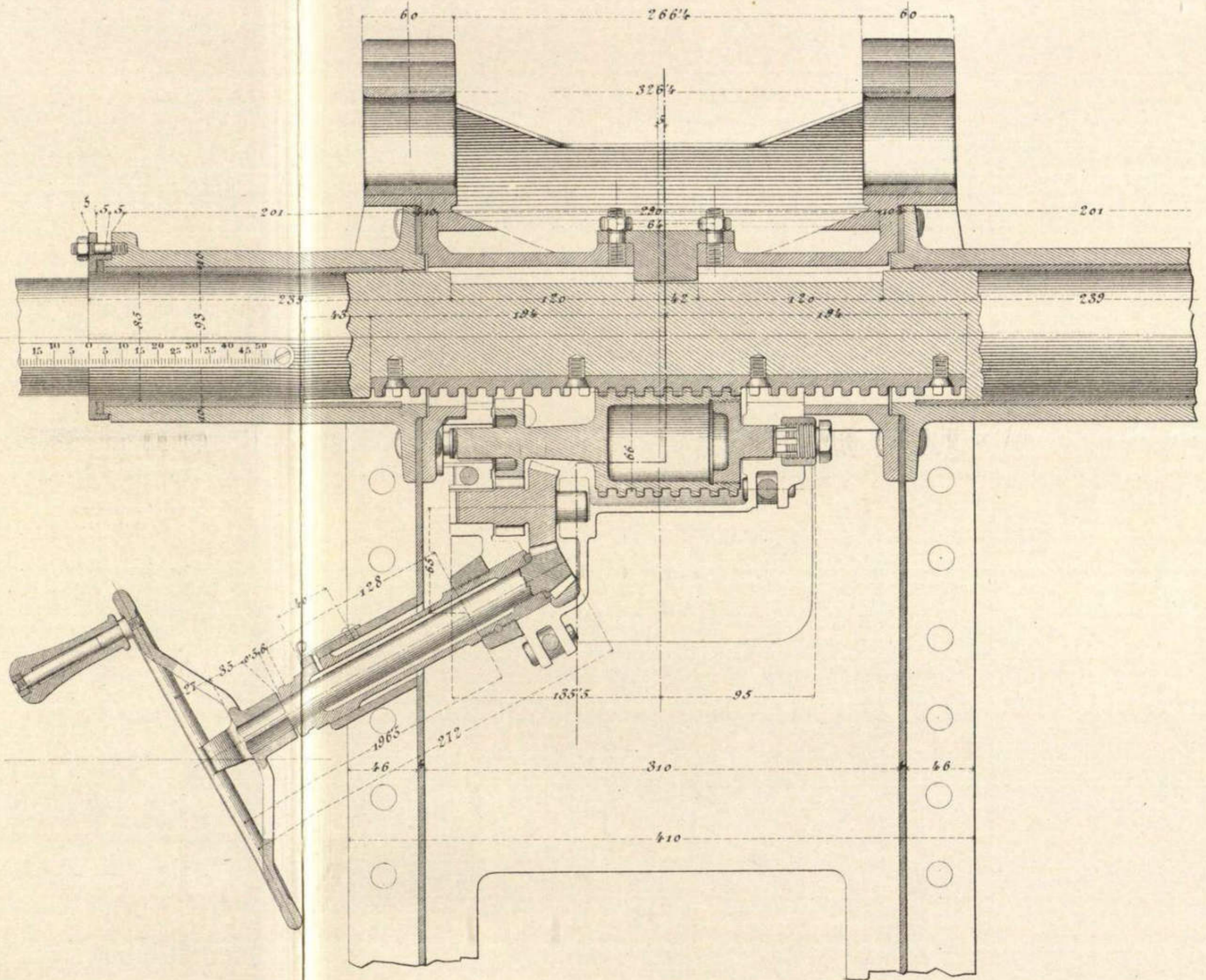
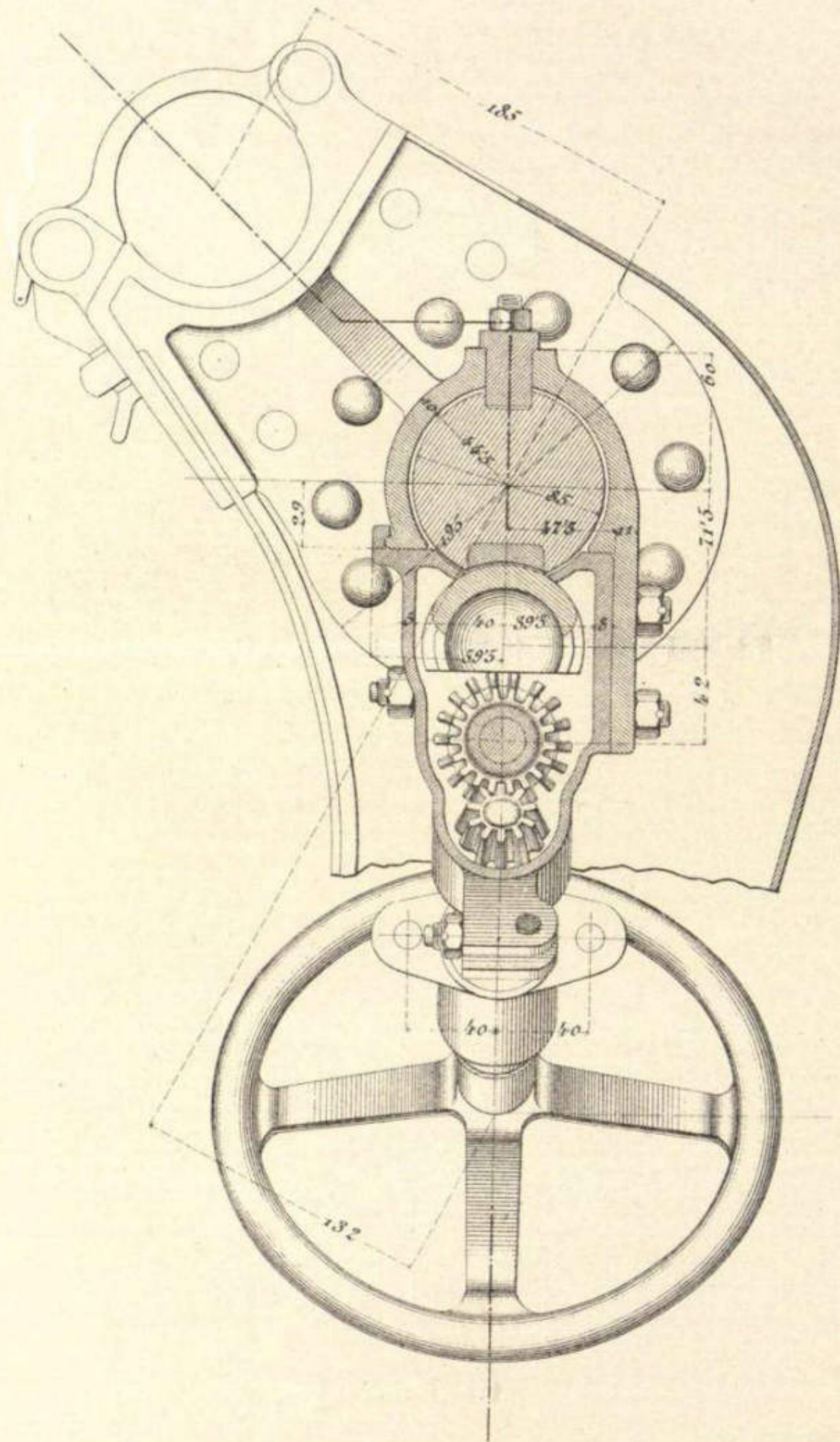

CUREÑA PARA CAÑÓN Ac. T. r. DE 7'5 cm. DE CAMPAÑA Md. 1906.

APARATO DE PUNTERIA EN DIRECCION.

DETALLES.

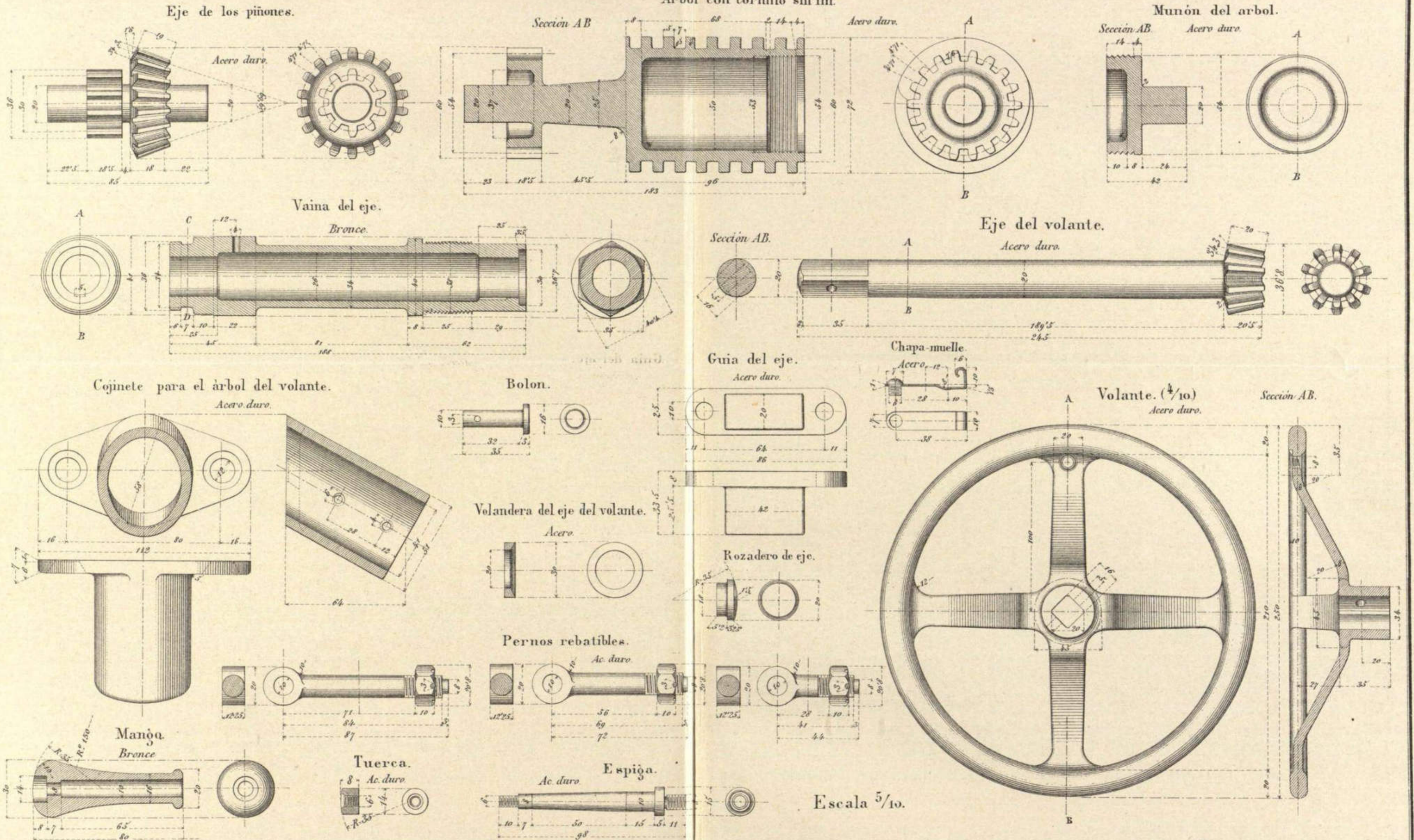

CUREÑA PARA CAÑÓN Ac. T. r. DE 7' 5 cm. DE CAMPAÑA Md. 1906.

APARATO DE DAR DIRECCIÓN DETALLES.

Telera de testera. (E=3/10.)

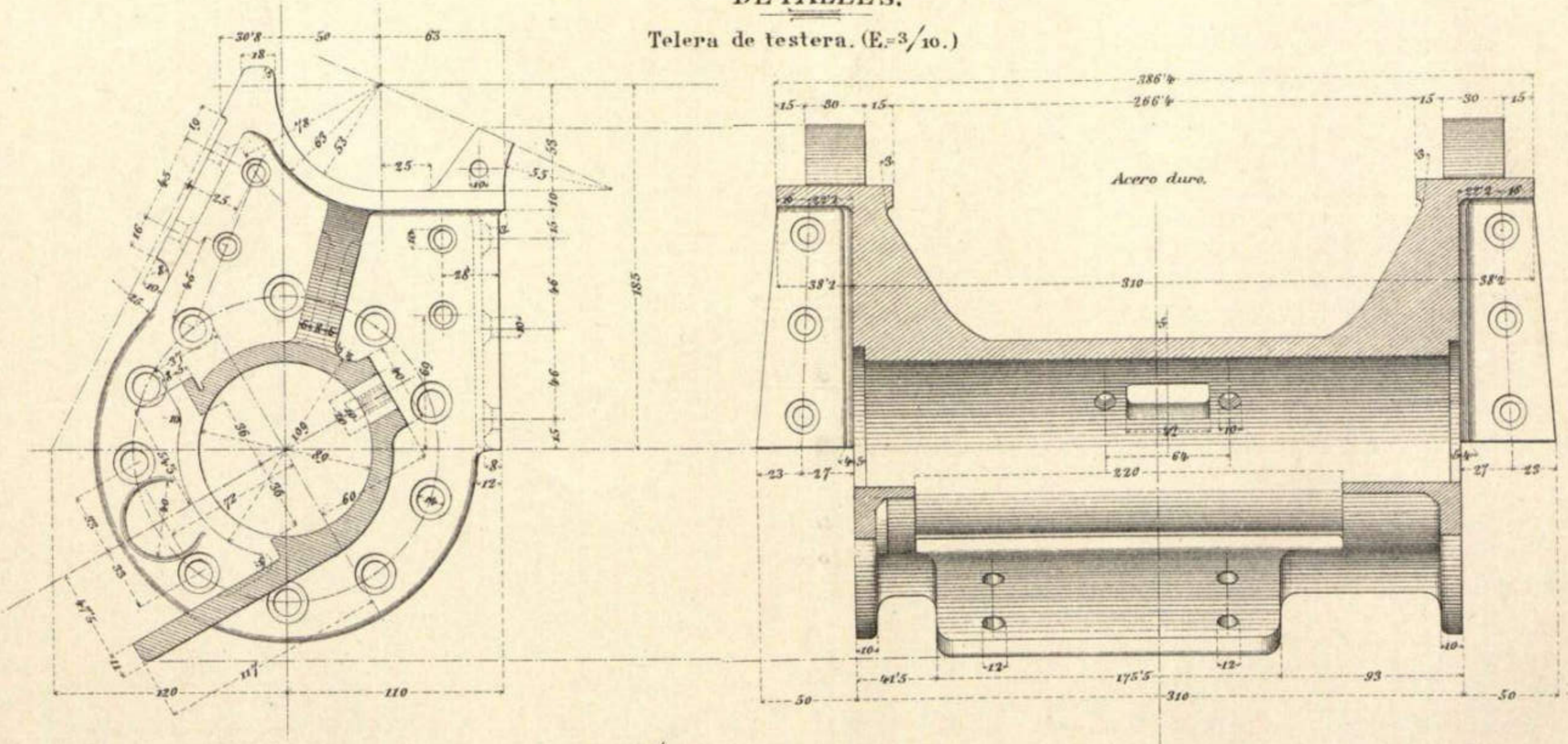

Cubierta. (E=5/10.)

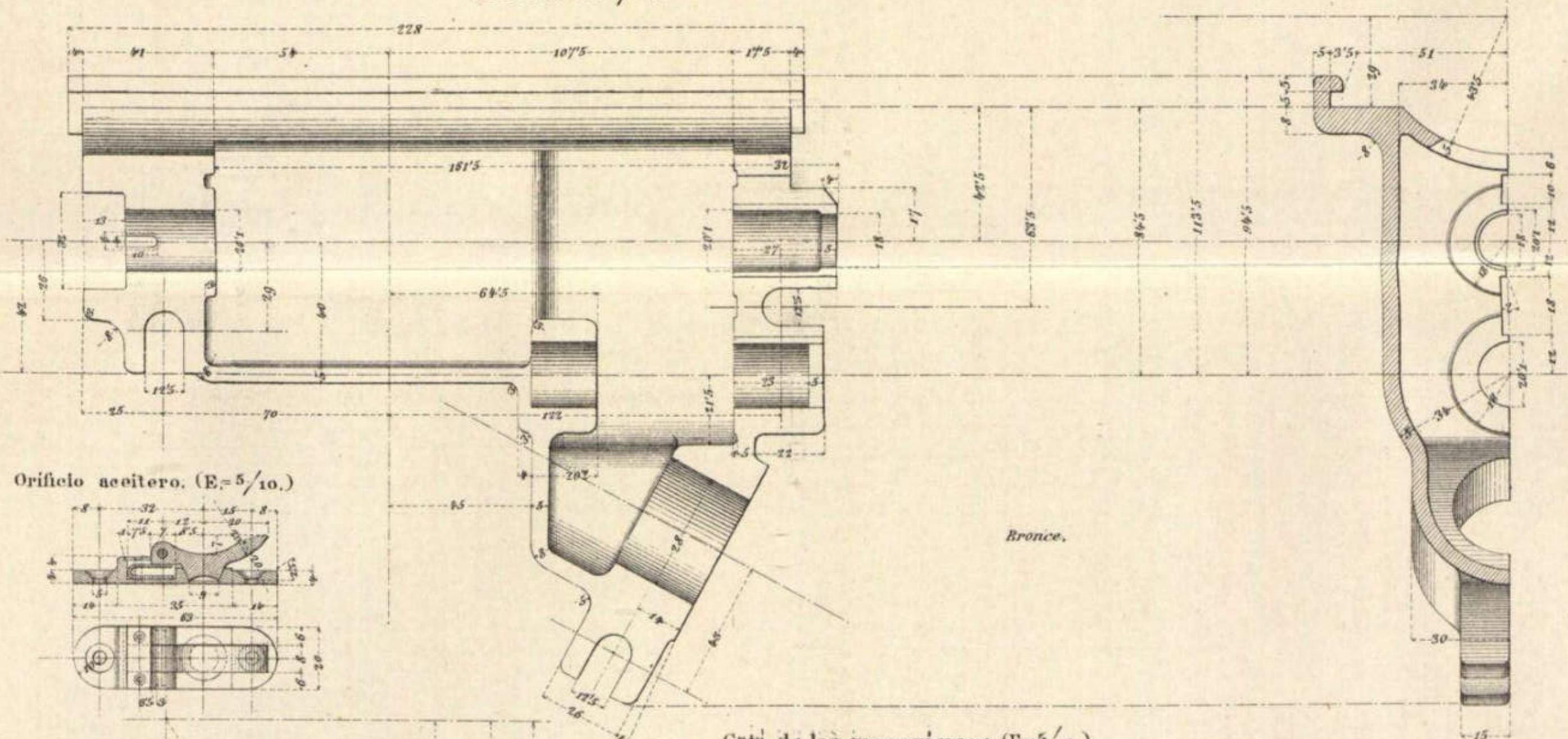

Orificio aceitero. (E=5/10.)

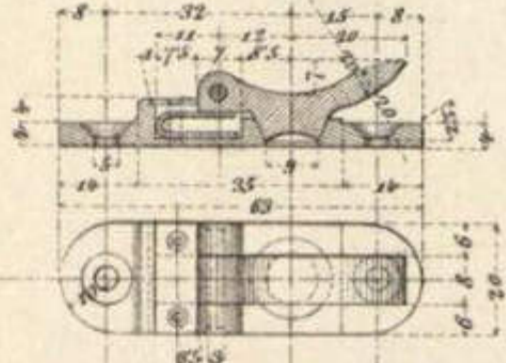

Caja de los mecanismos. (E=5/10.)

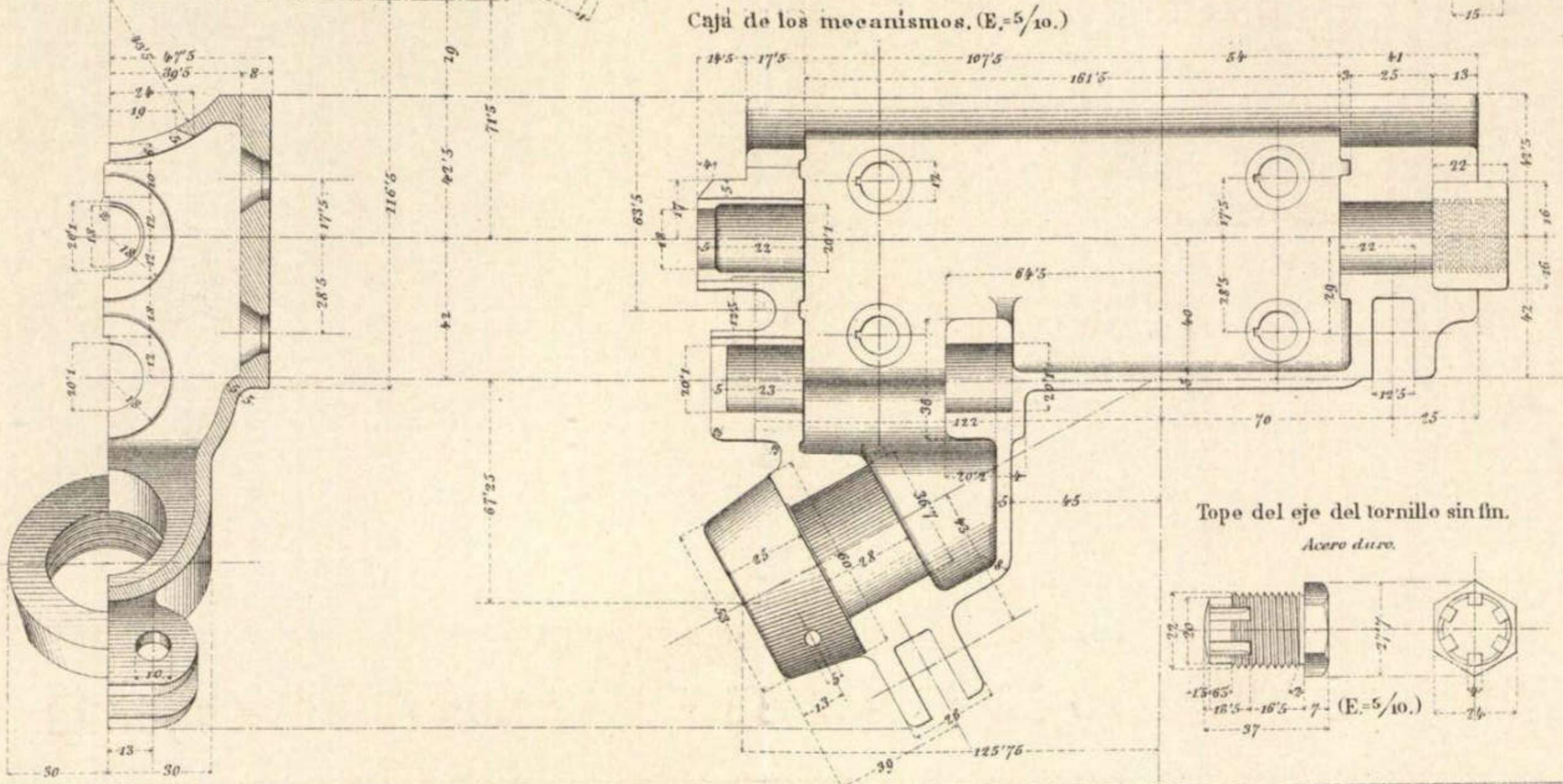

Tope del eje del tornillo sin fin.

Acero duro.

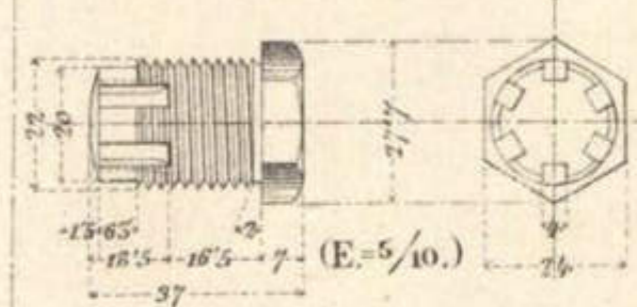

CUREÑA PARA CAÑON Ac. T. r. DE 7' 5 cm. DE CAMPAÑA Md. 1906.

DETALLES

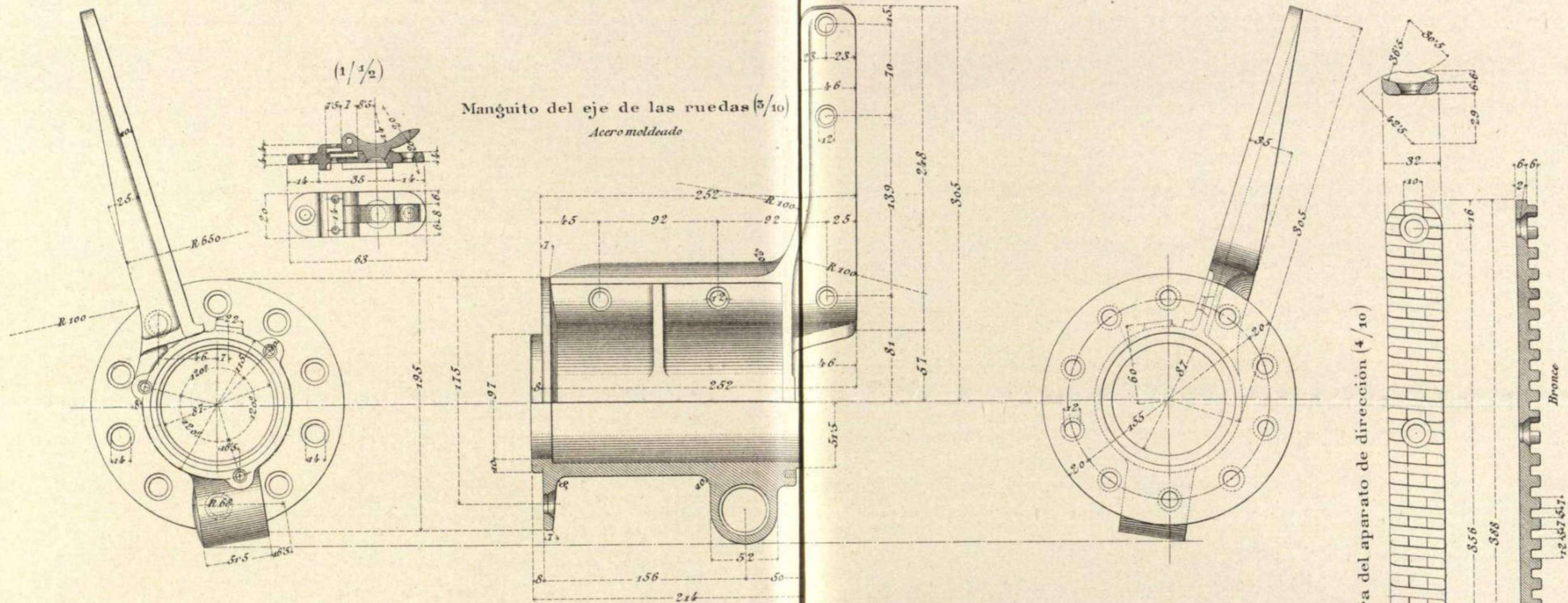

2 Volanderas-cierres. (4/10)

Acero duro

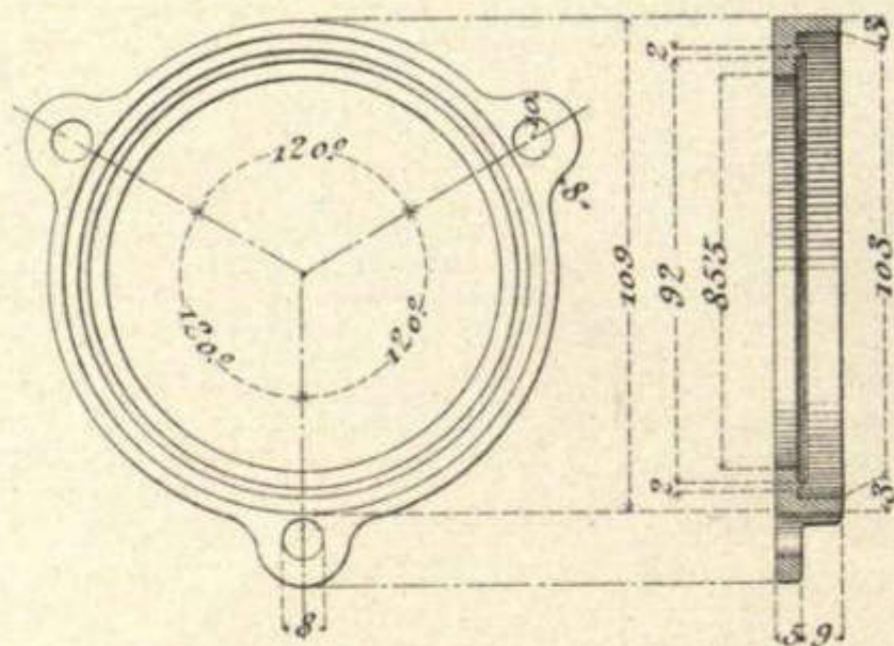

Arandela (4/10)

Cuero

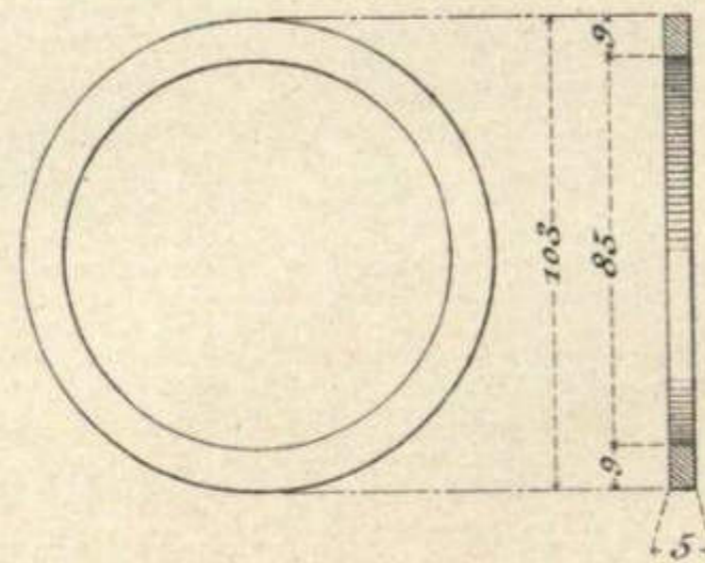

Tubo. (4/10)

Bronce

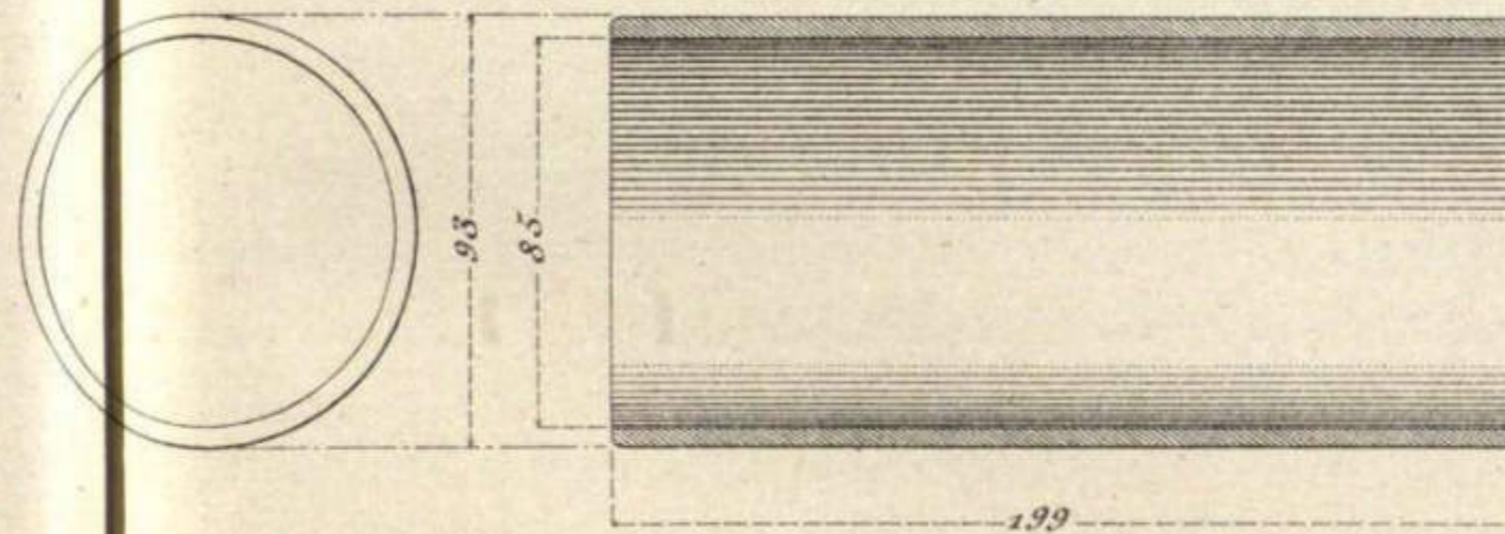

Cremallera del aparato de direccion (4/10)

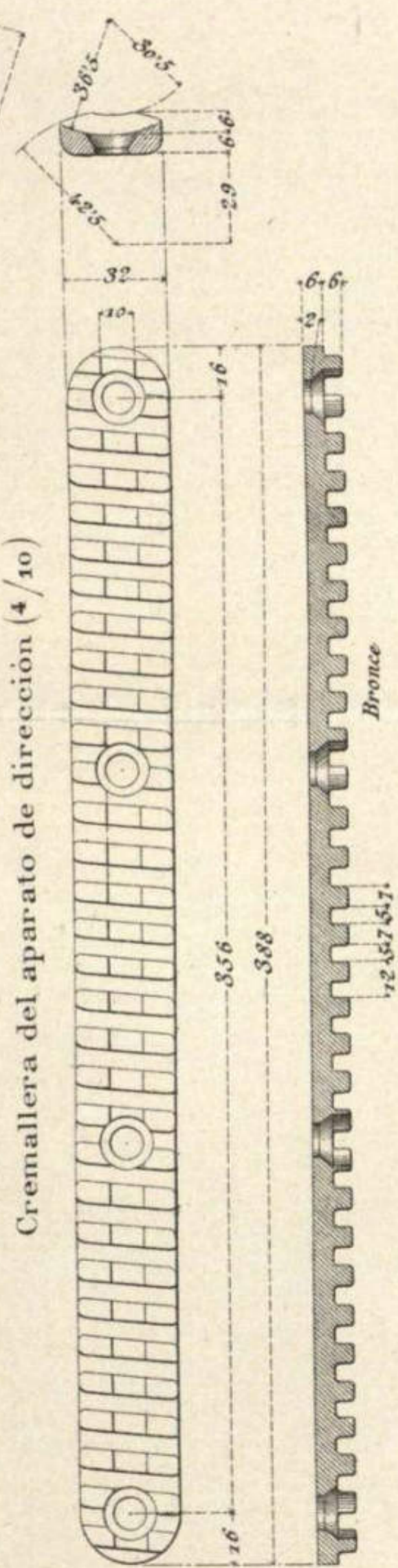

CUREÑA PARA CAÑON Ac. T. r. DE 7' 5 cm. DE CAMPAÑA Md. 1906.

DETALLES DEL ESCUDO

Parte superior. (E=1/10.)

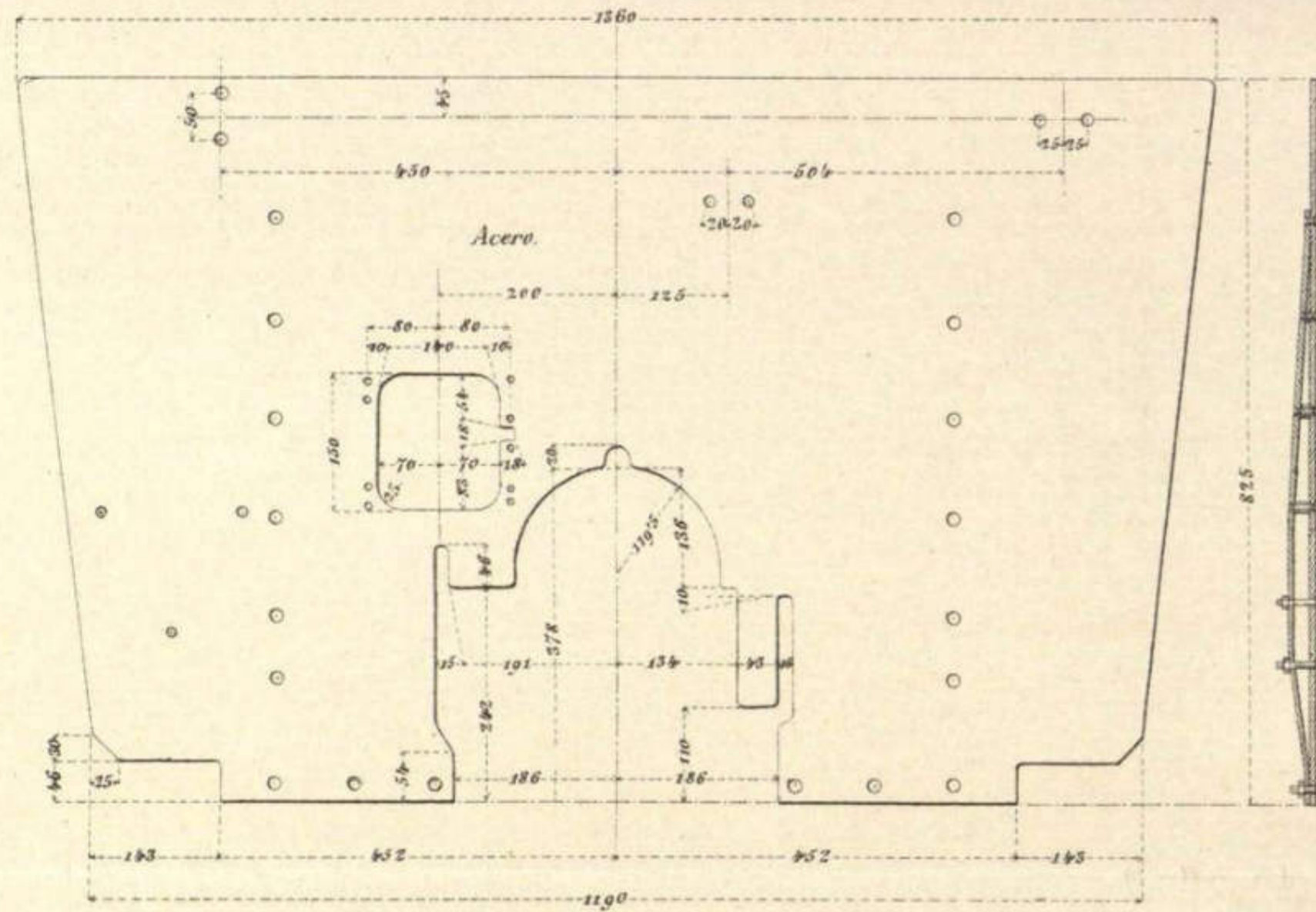

Parte inferior. (E=1/10.)

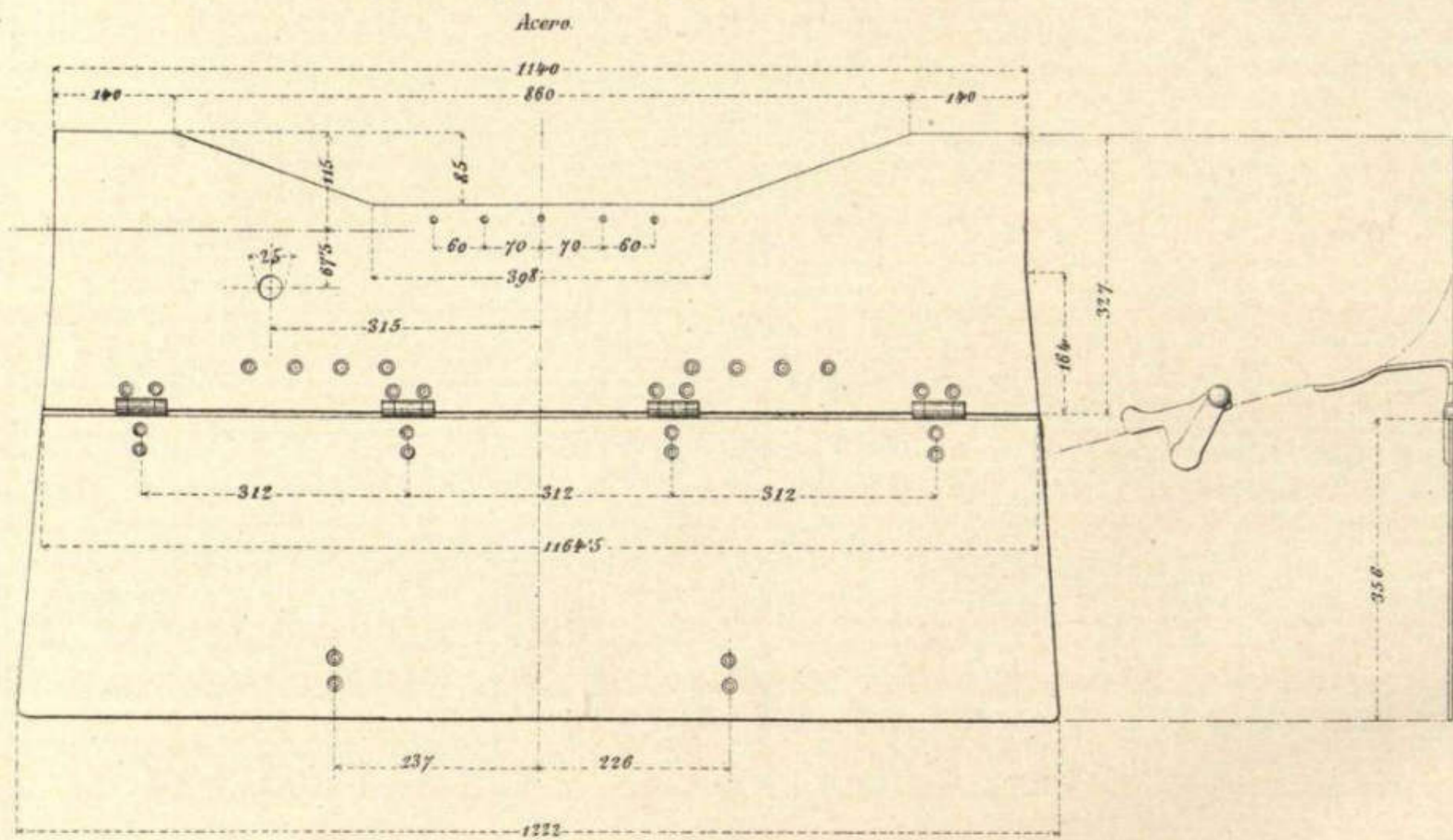

Puerta de la ventana de puntería. (E=3/10.)

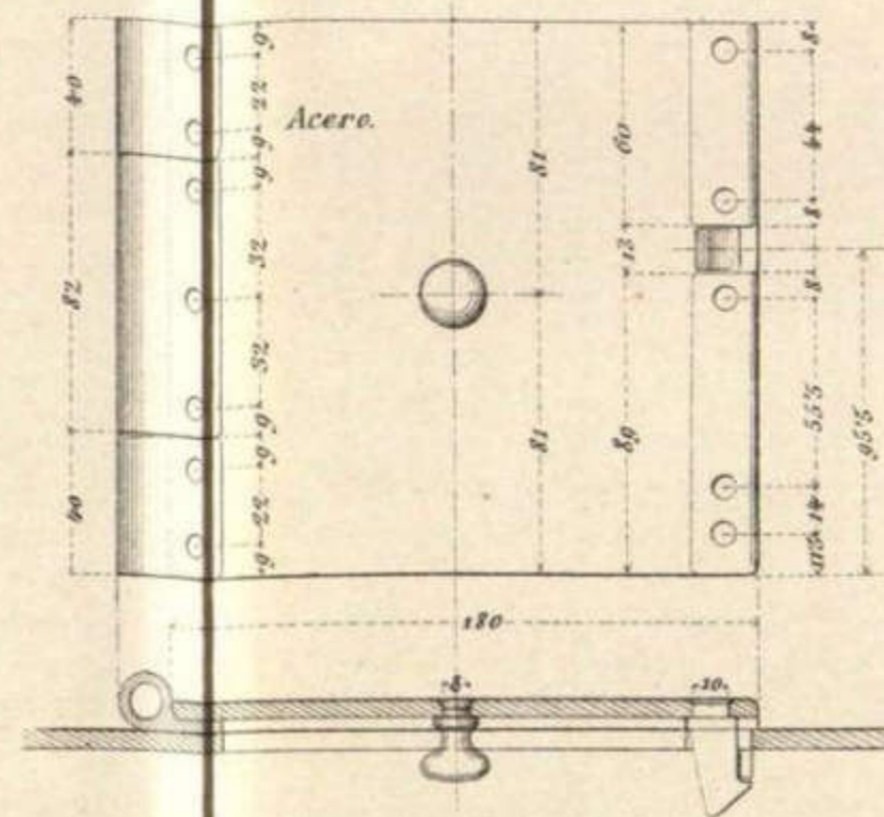

Muelle. (E=1/2.)

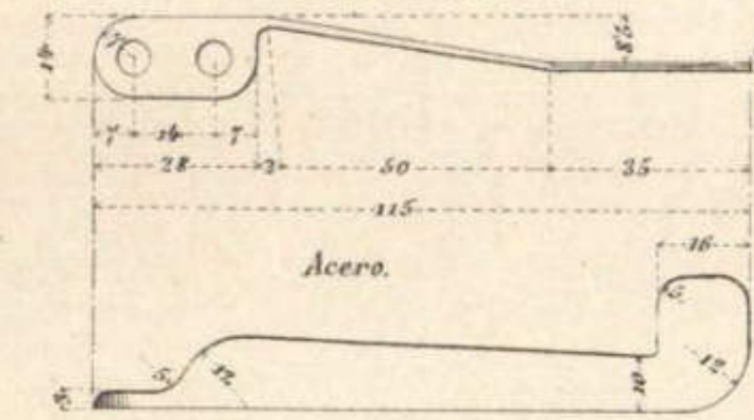

Refuerzo. (E=1/2.)

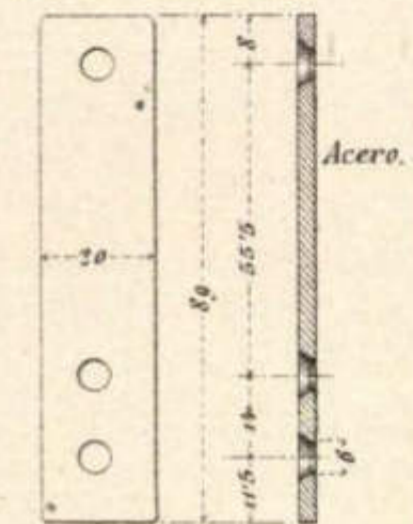

Visağras. (E=1/2.)

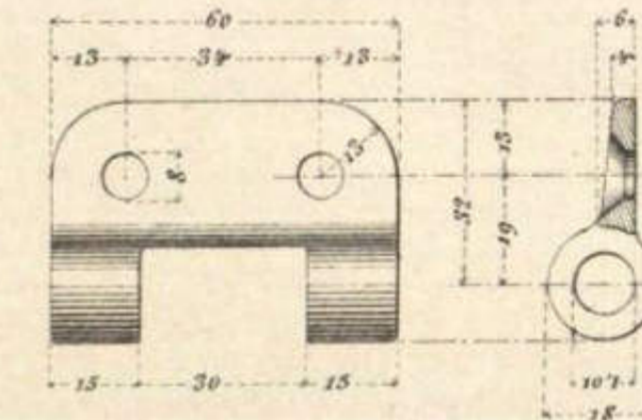

Boton. (E=1/2.)

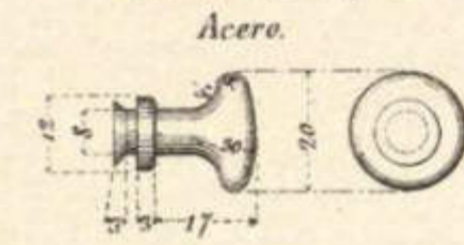

Visağras. (E=1/2.)

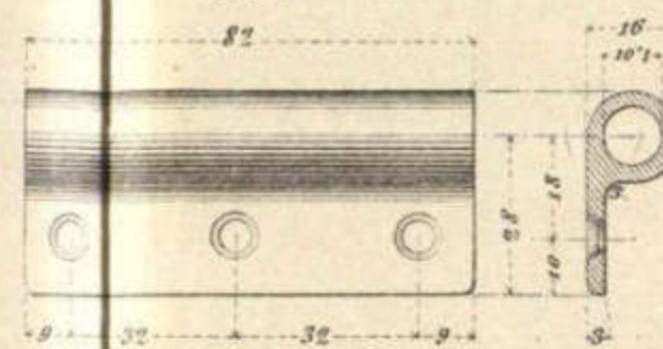

Refuerzo. (E=1/2.)

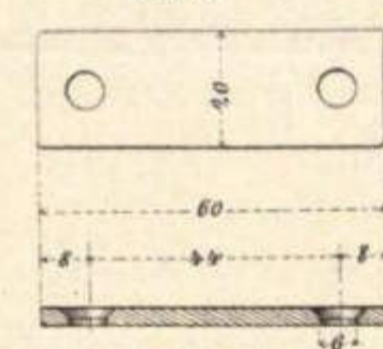

Eje de las visağras. (E=1/2.)

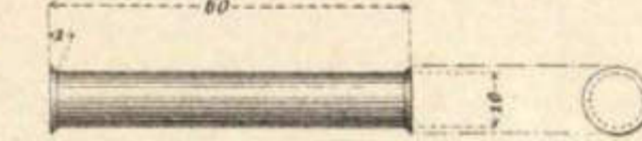

Refuerzos. (E=2/10.)

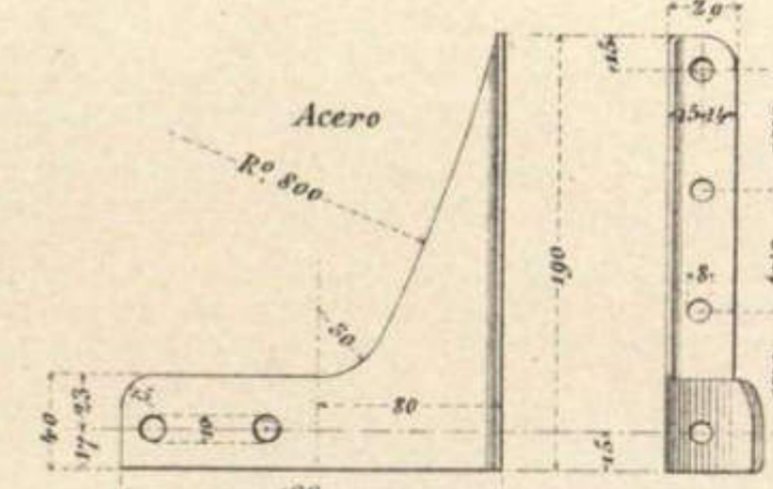

Picolete. (E=1/2.)

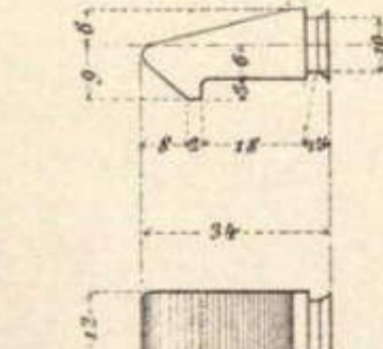

Ganchos. (E=1/2.)

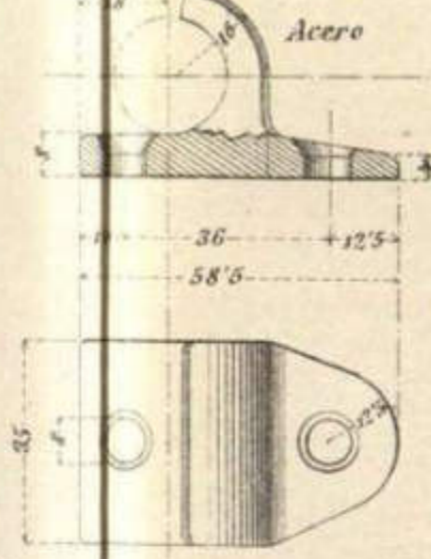

Pernos. (E=1/2.)

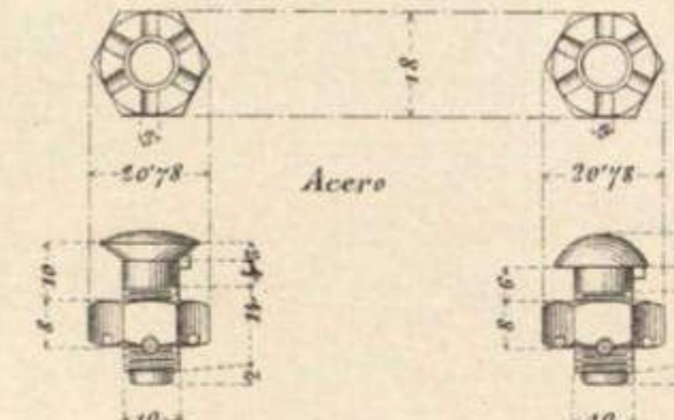

Visağras. (E=1/2.)

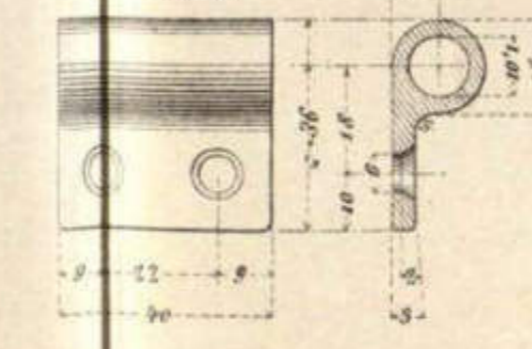

Visağras. (E=1/2.)

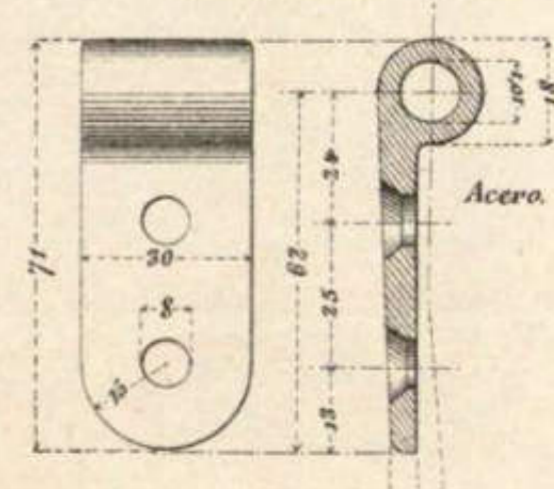

CUREÑA PARA CAÑÓN Ac. T. r. DE 7' 5 cm. DE CAMPAÑA Md. 1906.

DETALLES DE LA CUNA

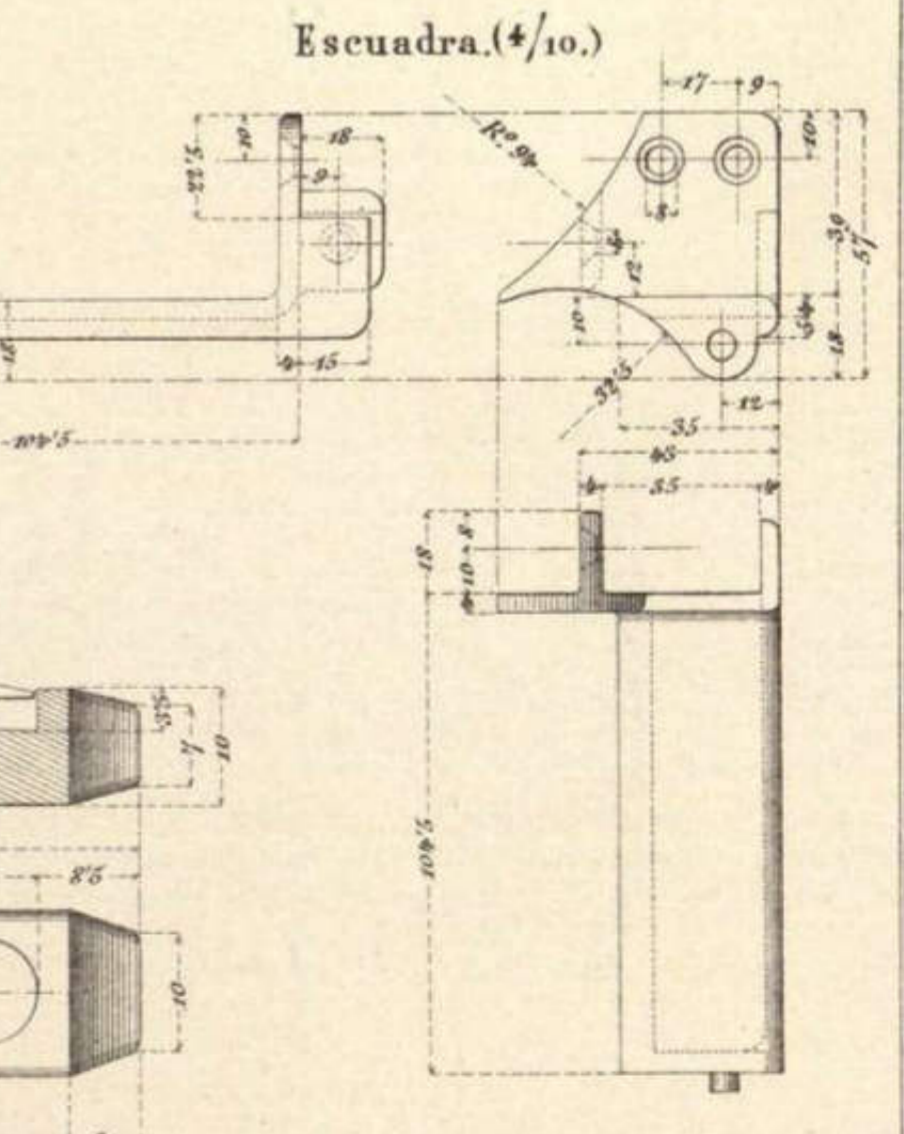
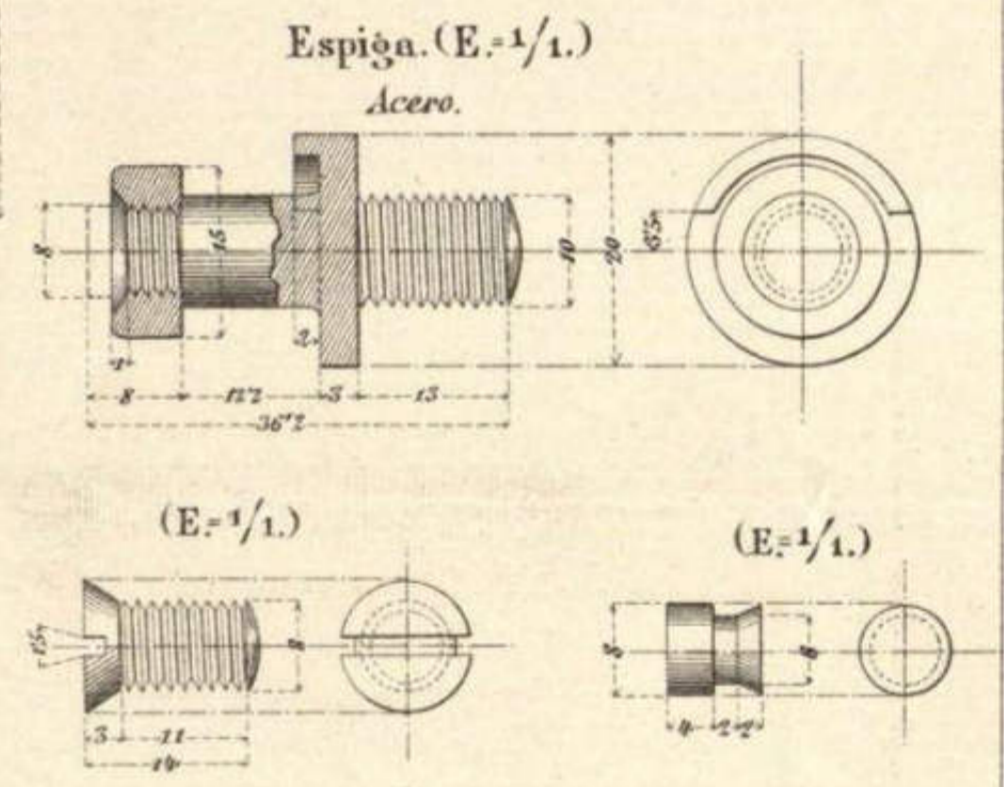
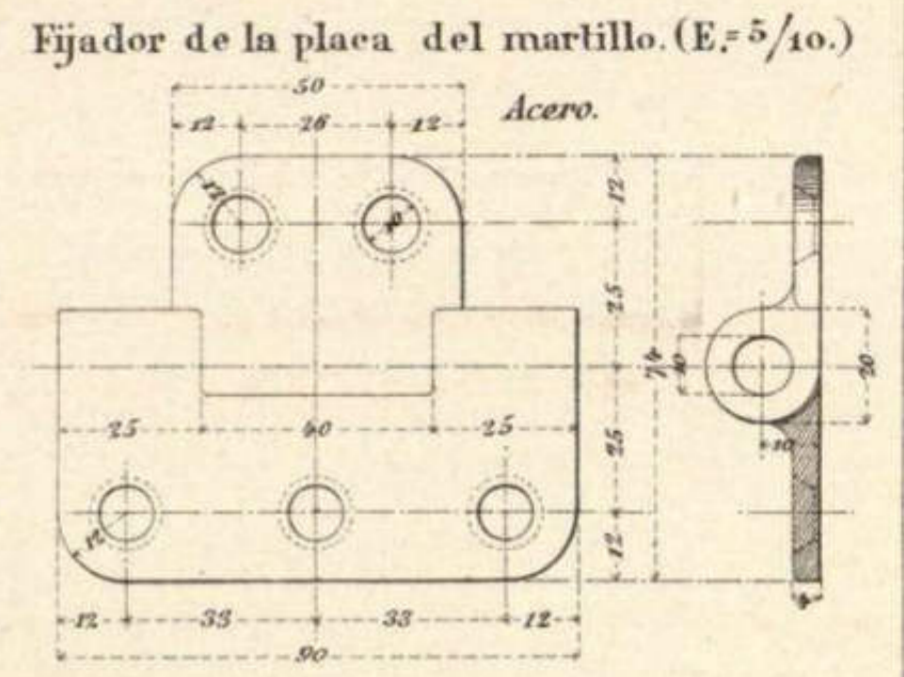
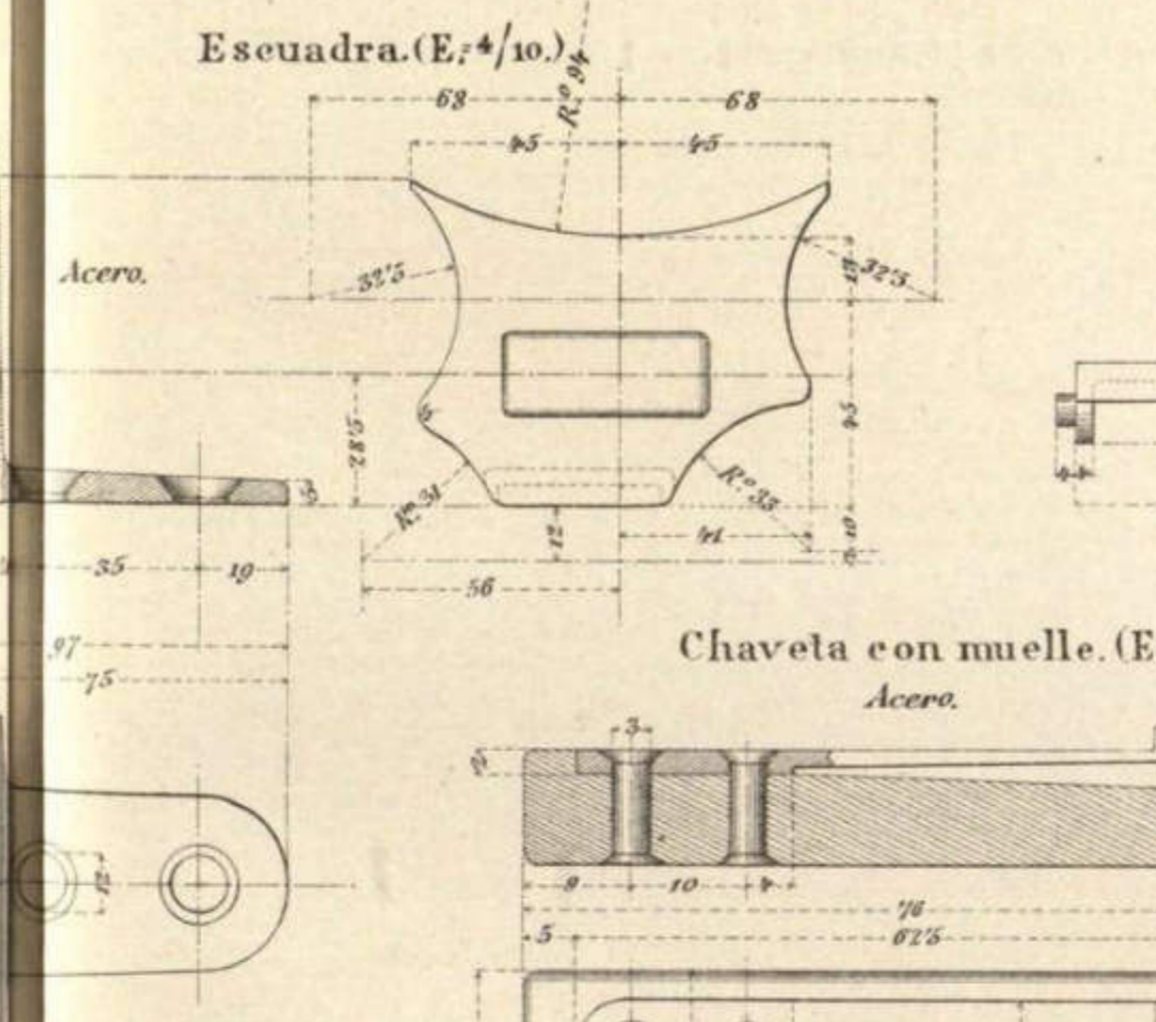
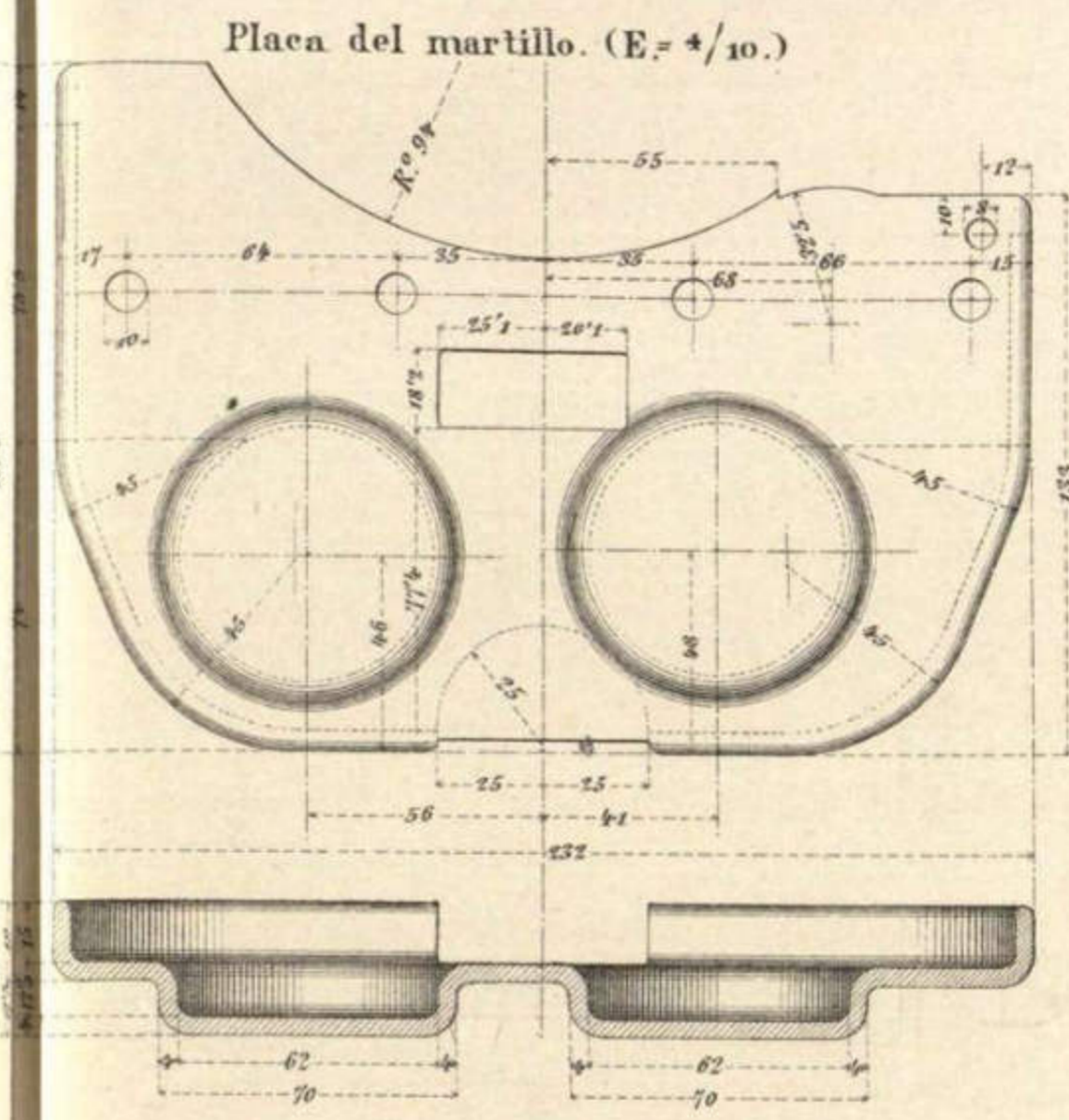
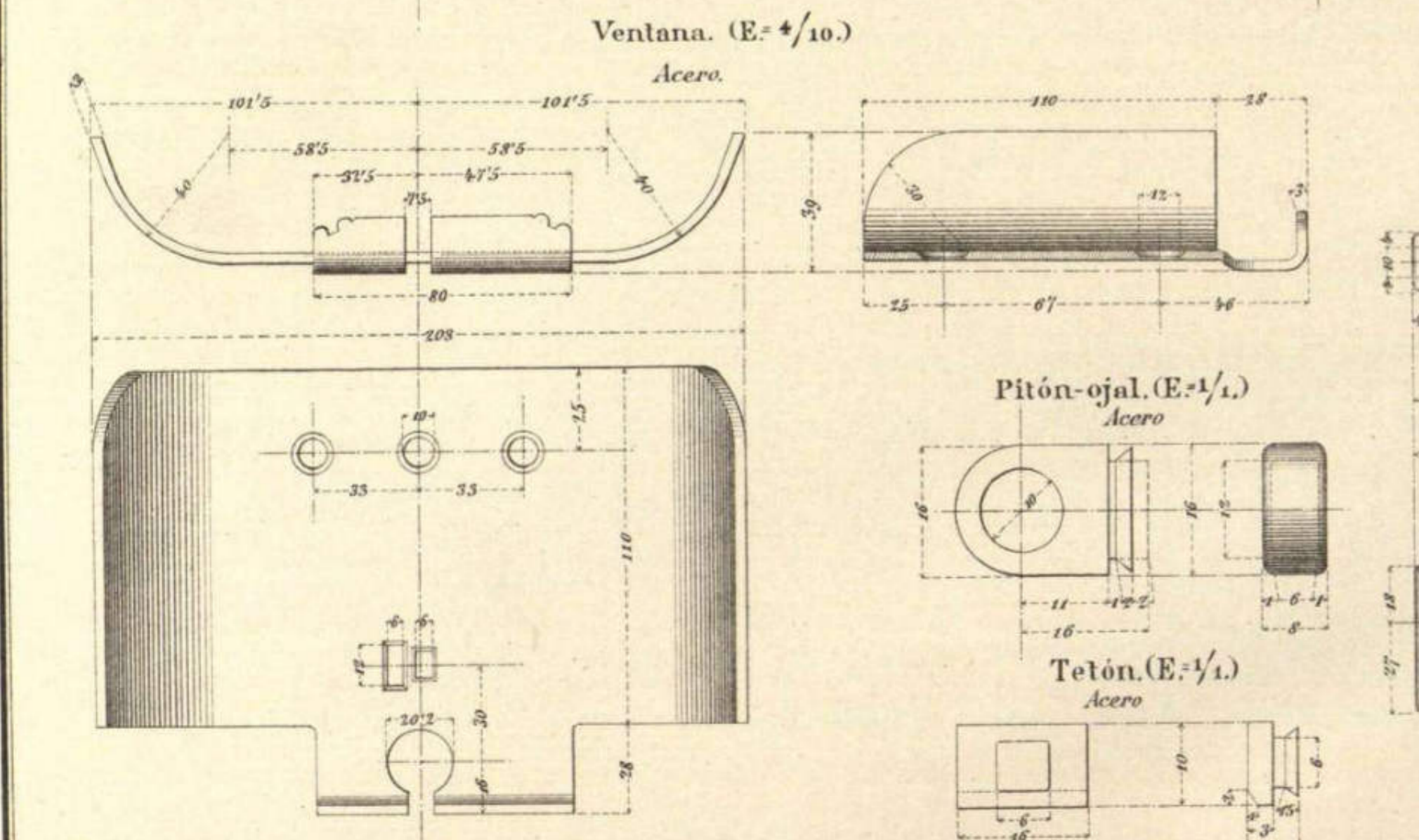
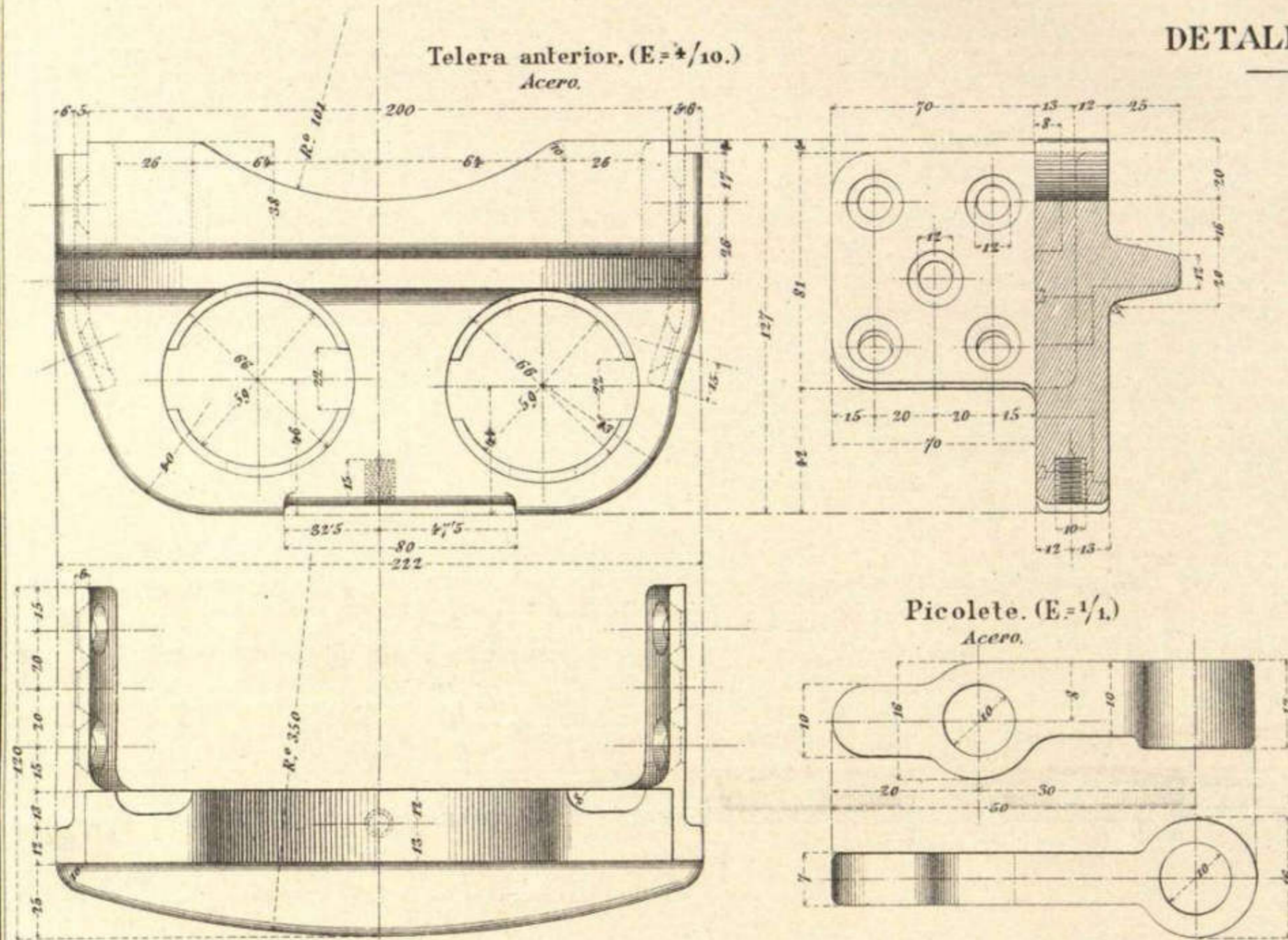

CUREÑA PARA CAÑÓN Ac. T. r. DE 7' 5 cm. DE CAMPAÑA Md. 1906.

FRENO RECUPERADOR

Escala 4/10

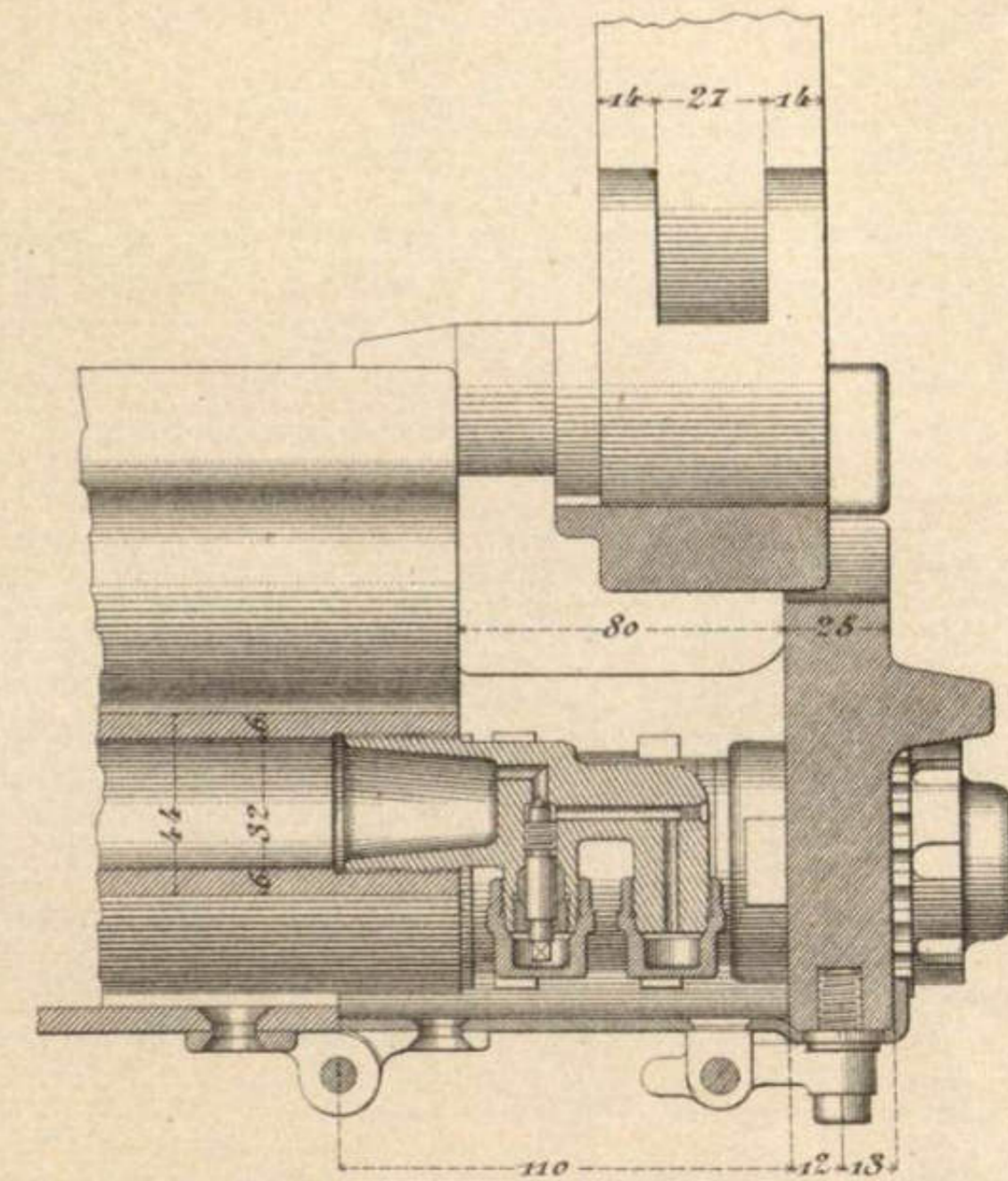
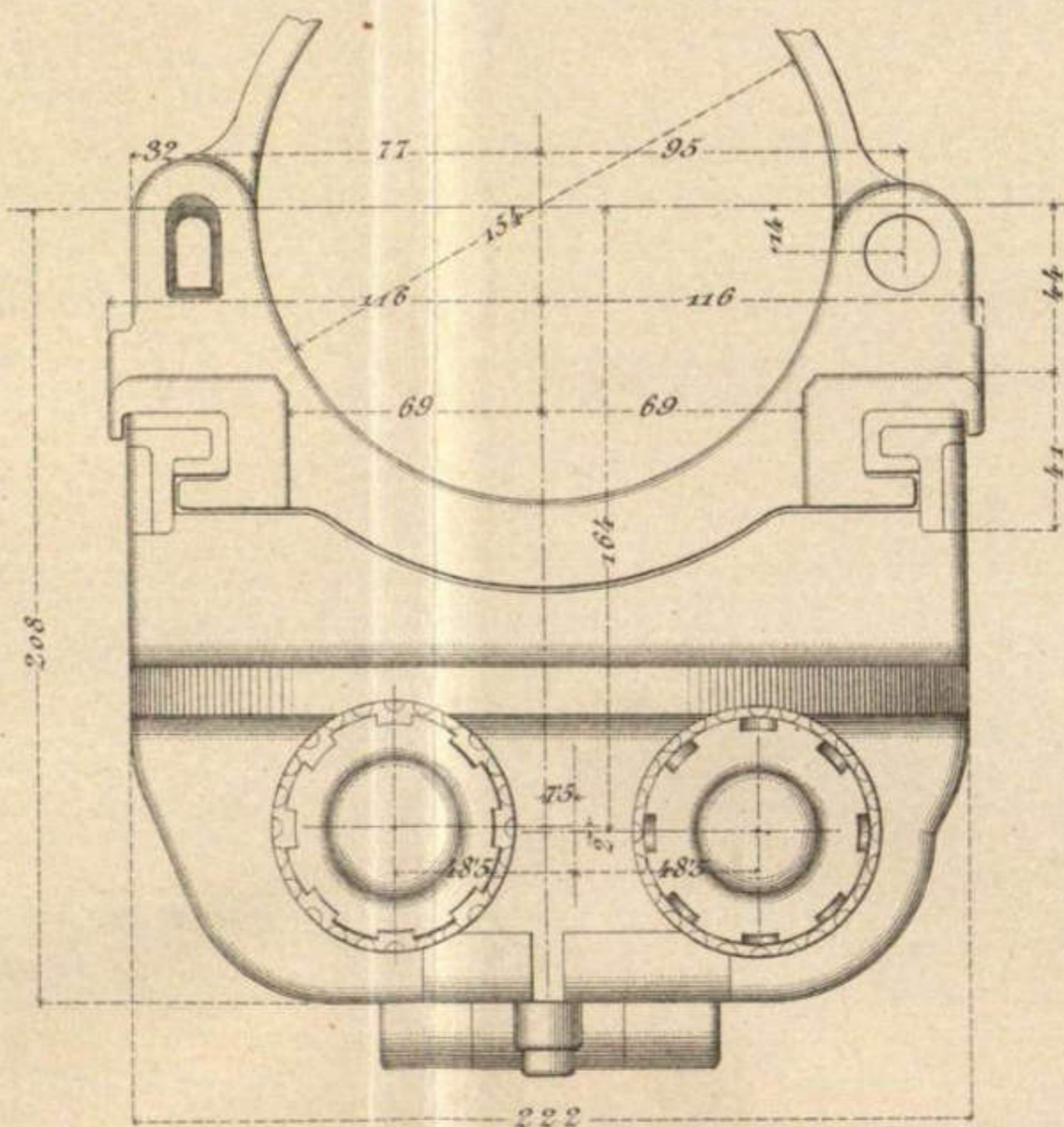
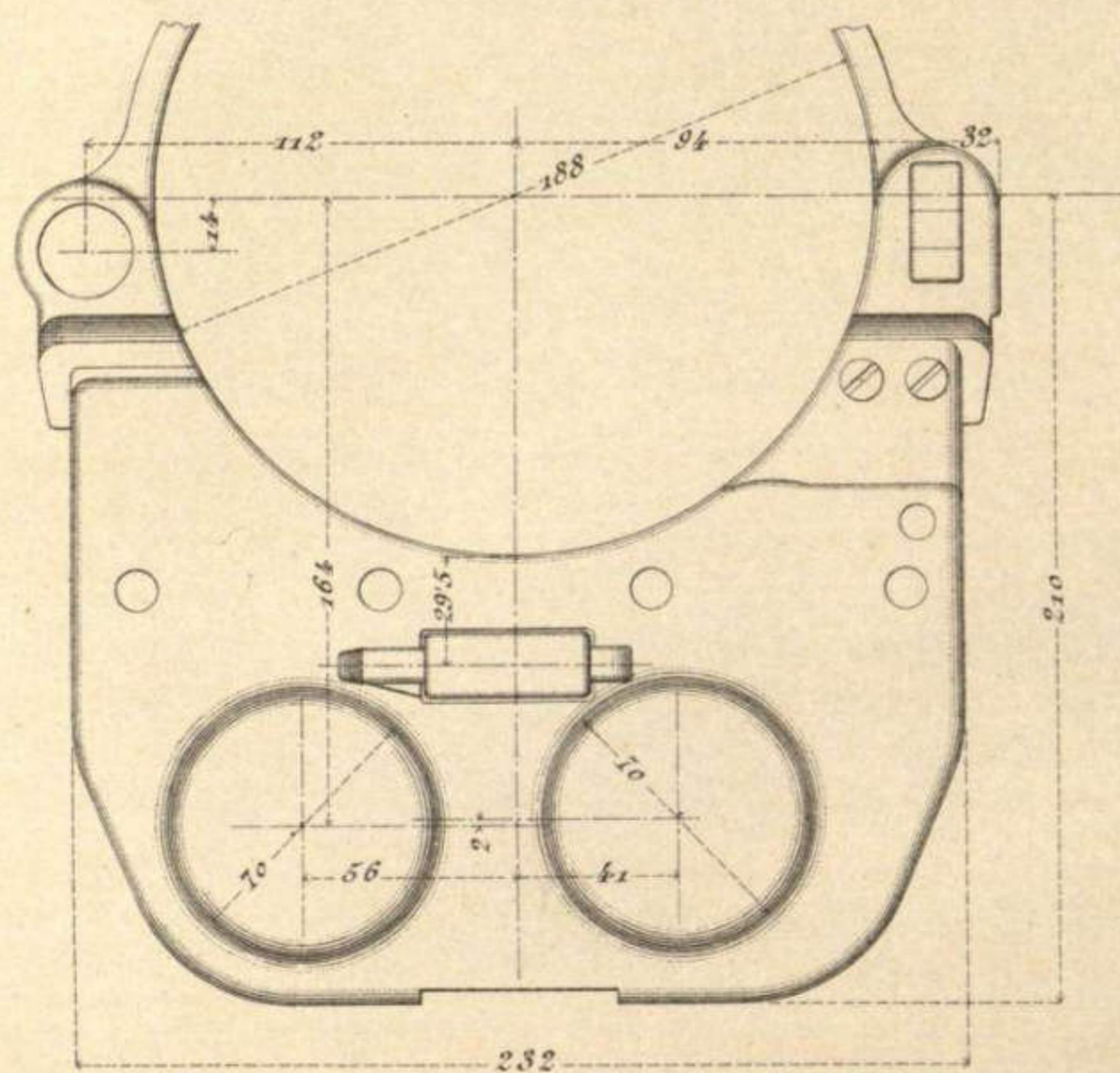
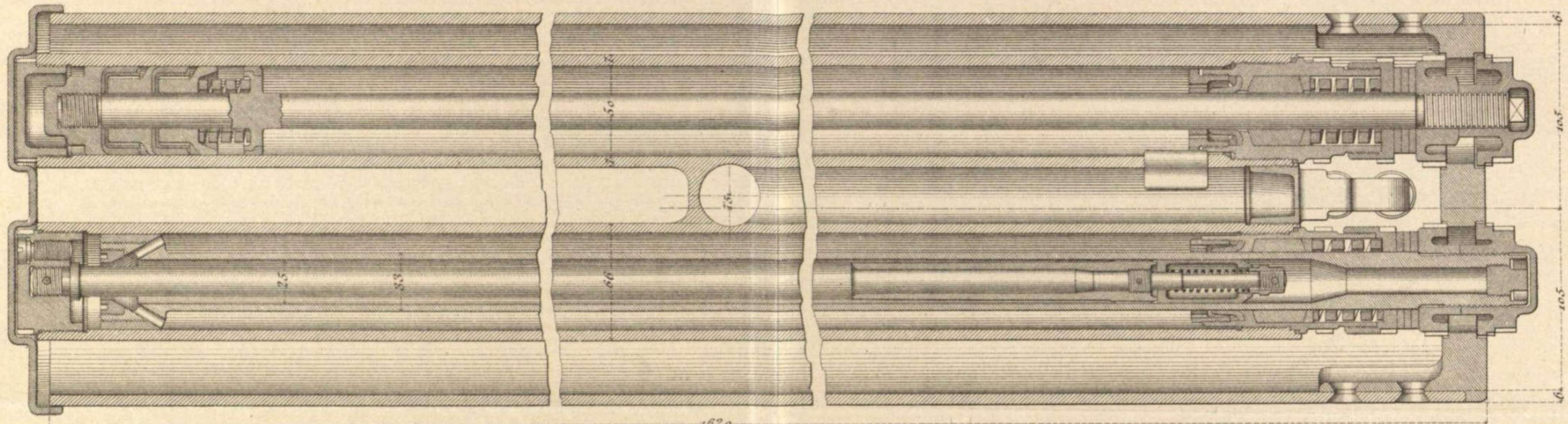

CUREÑA PARA CAÑÓN Ac. T. r. DE 7' 5 cm. DE CAMPAÑA Md. 1906.

DETALLES DEL FRENO.

Escala 4/10.

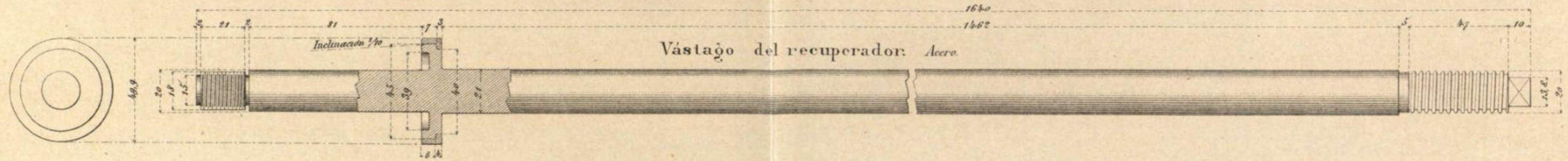

Vástago del recuperador: Acero

Tapón posterior

Bronce.

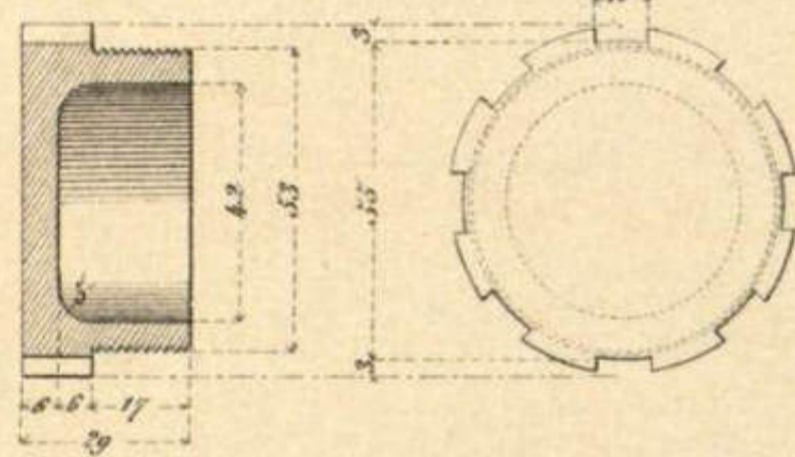

Tuerca de compresión.

Bronce.

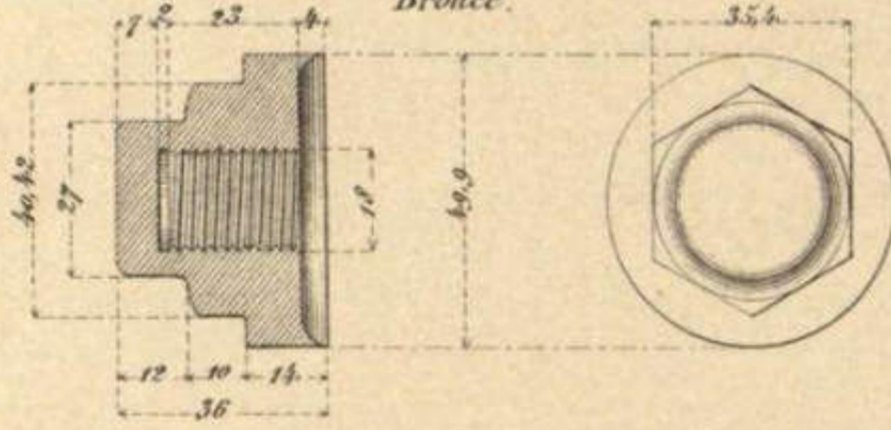

Contratuerca.

Acero.

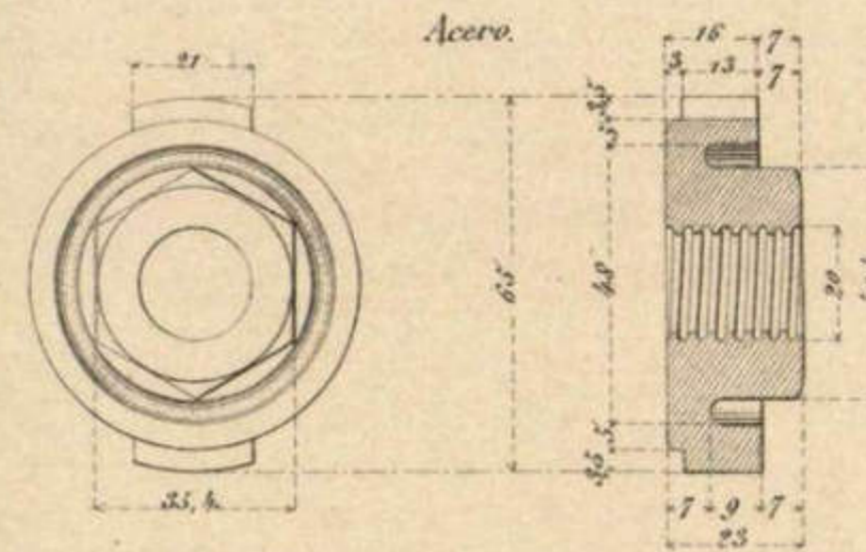

Tuerca.

Acero.

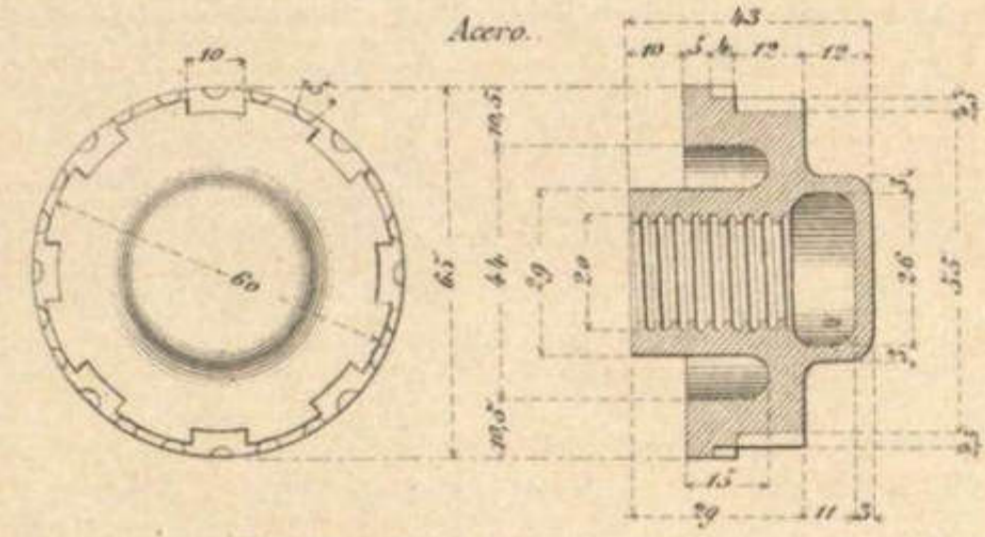

Opérculo de cuero.

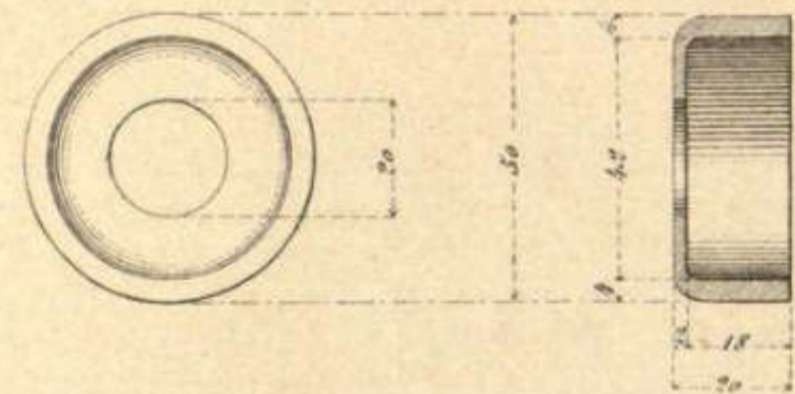

Muelle.

Acero.

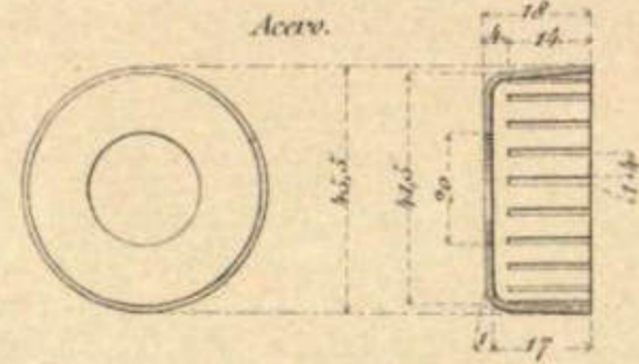

Caja de estopa.

Acero.

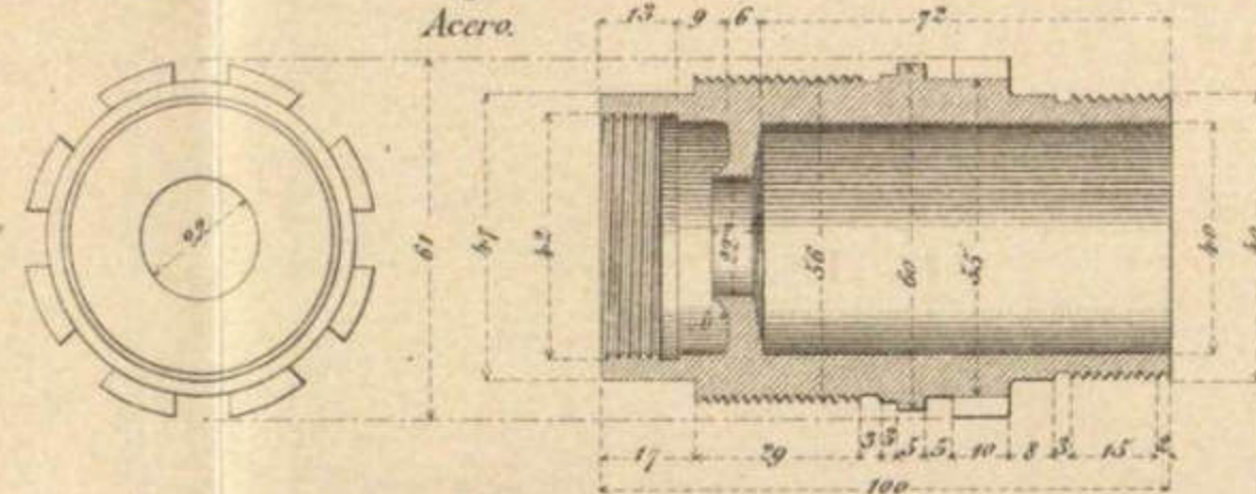

Tapa de la caja de estopas.

Bronce.

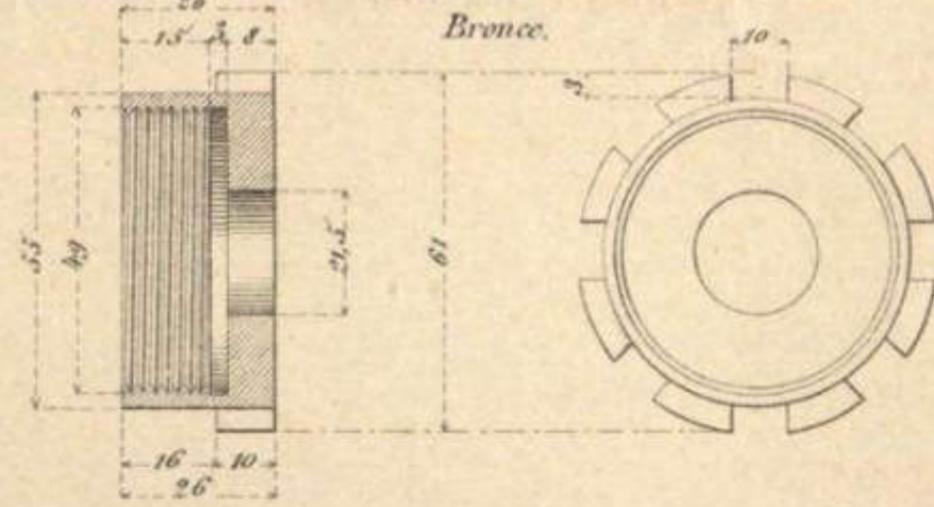

Copela.

Bronce.

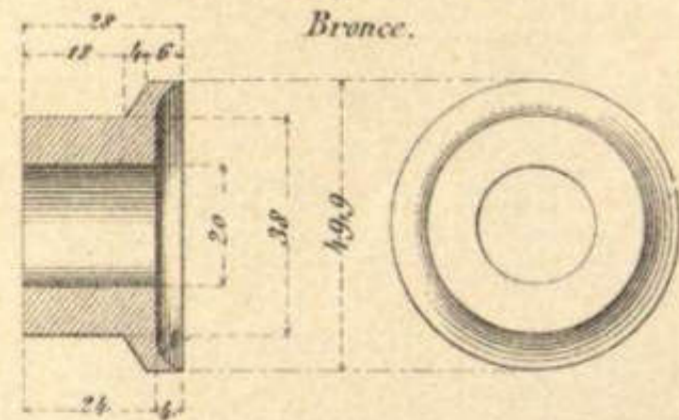

Copela.

Bronce.

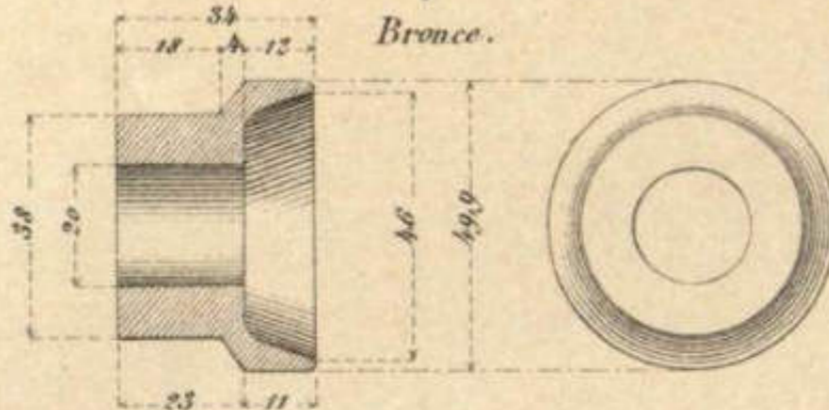

Guarnición.

Bronce.

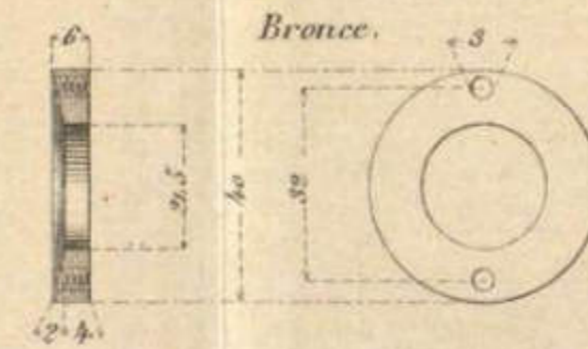

Muelle.

Acero.

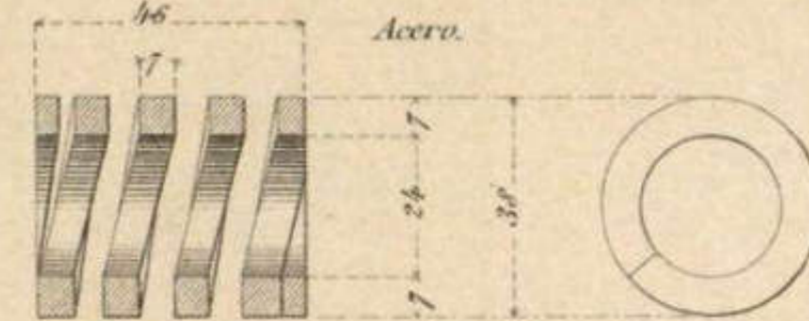

Arandela.

Cuero.

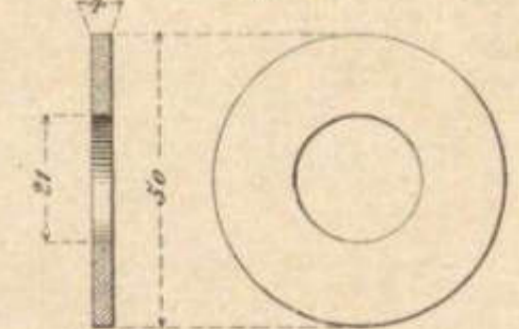

Muelle.

Acero.

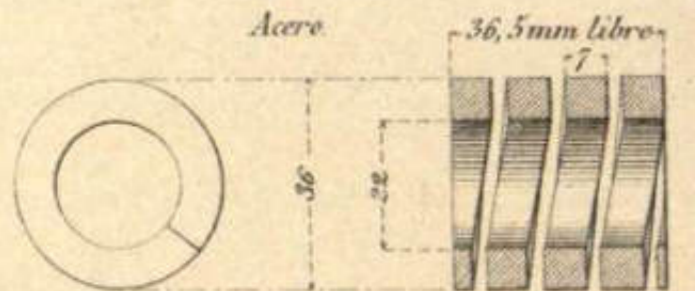

Flecha... 4,5
Carga... 206 kg.

Tapa roscada.

Bronce.

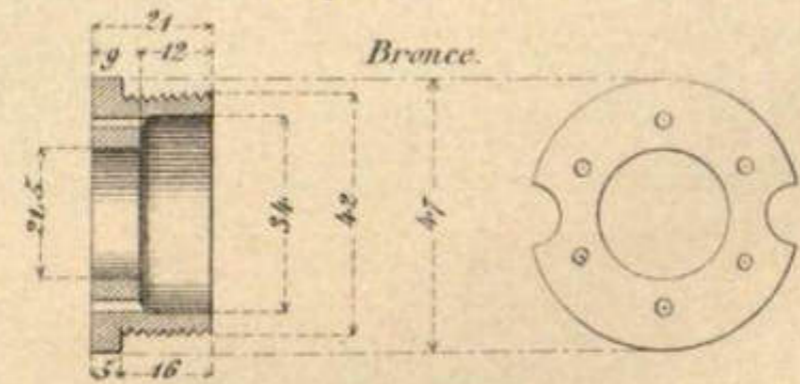

Anillo.

Cobre.

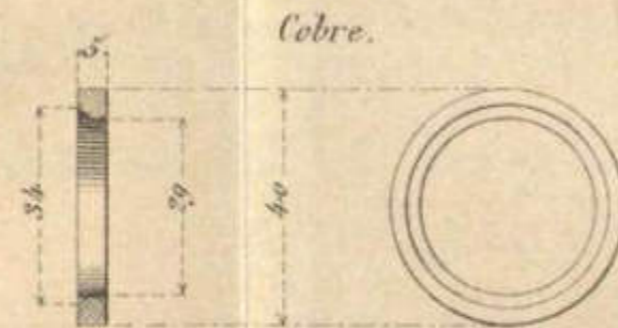

Opérculo de cuero.

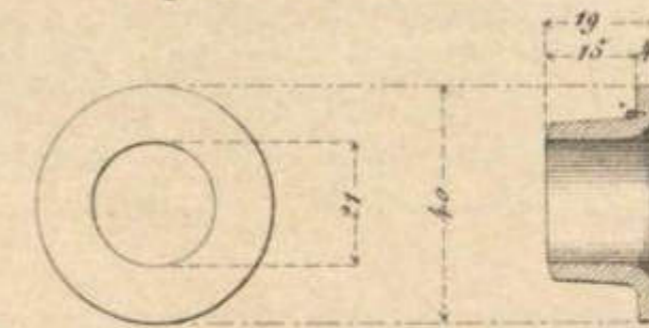

Trenza.

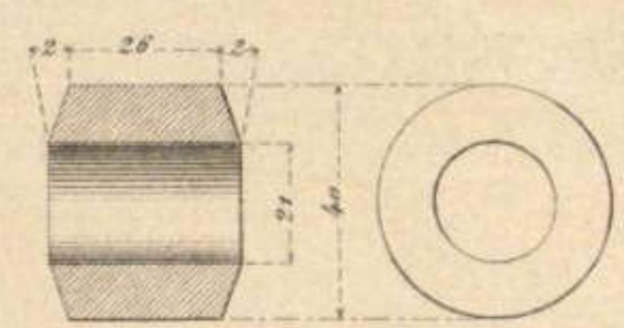

ACCESORIOS PARA EL MATERIAL DE CAMPAÑA Md. 1906.

Bomba.

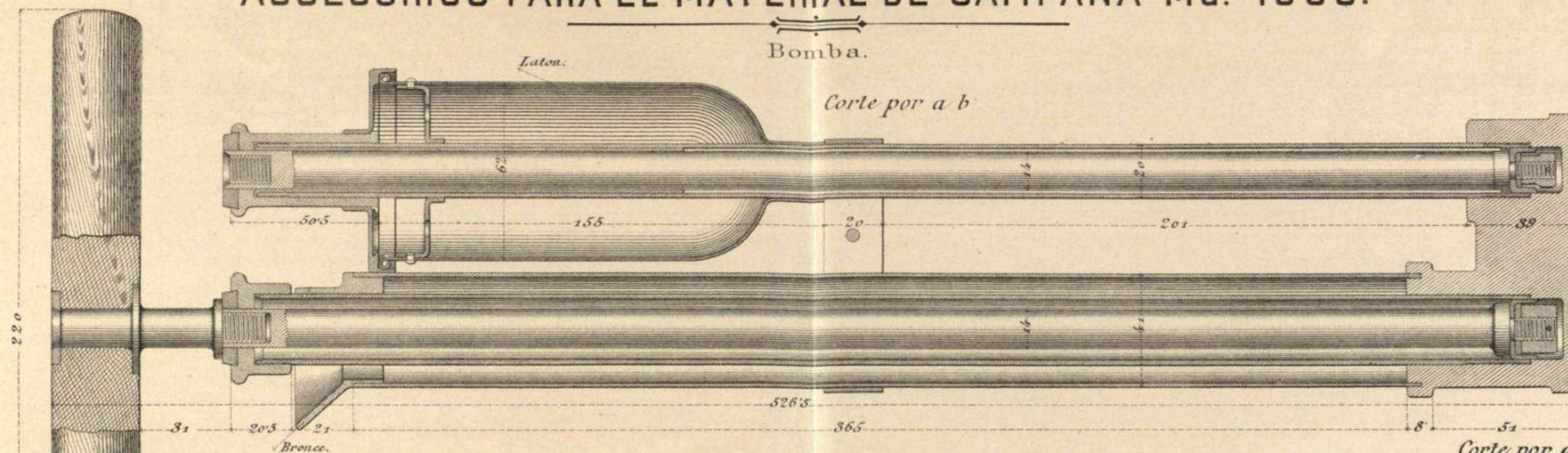

Escala 6/10

Corte por e f.

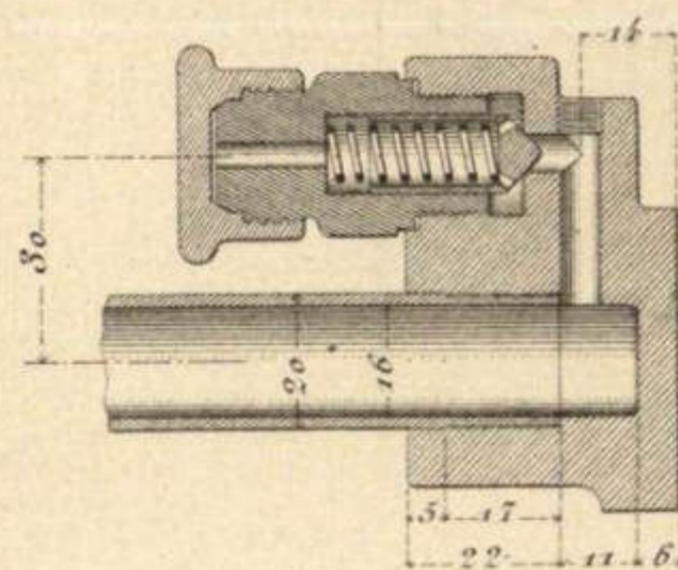

Corte por c d.

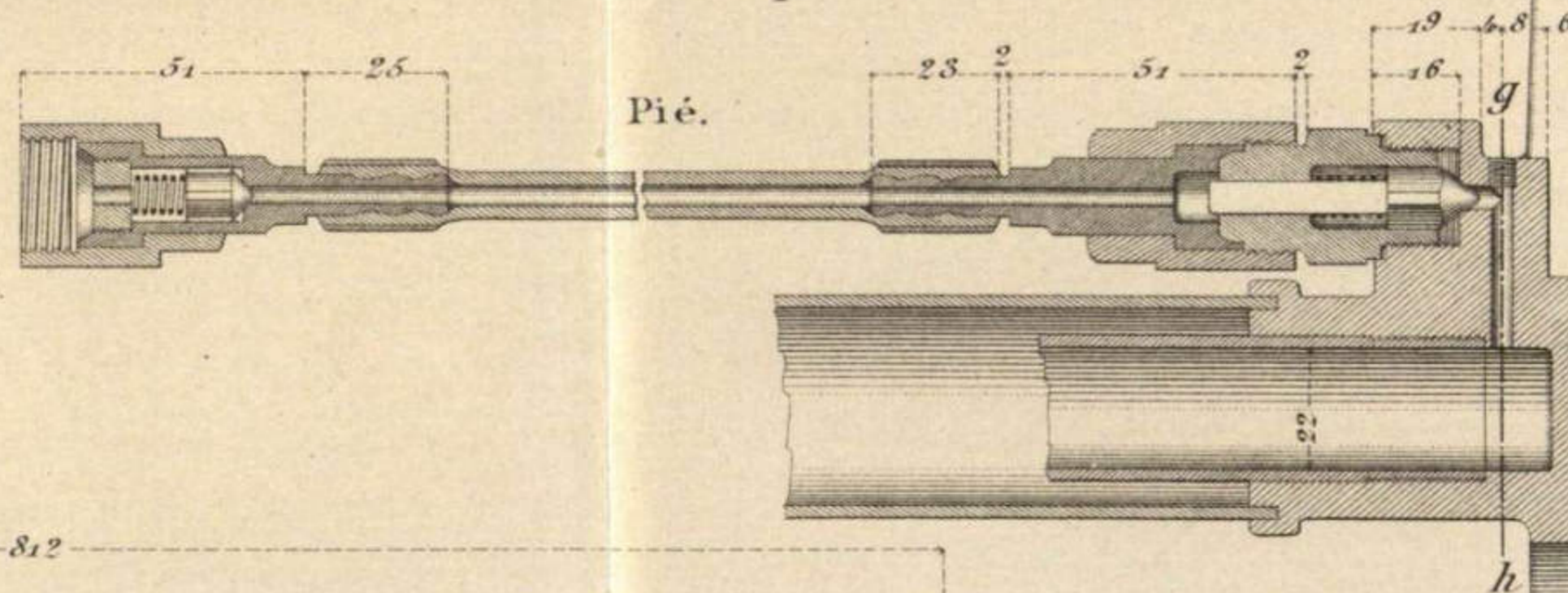

Corte por g h.

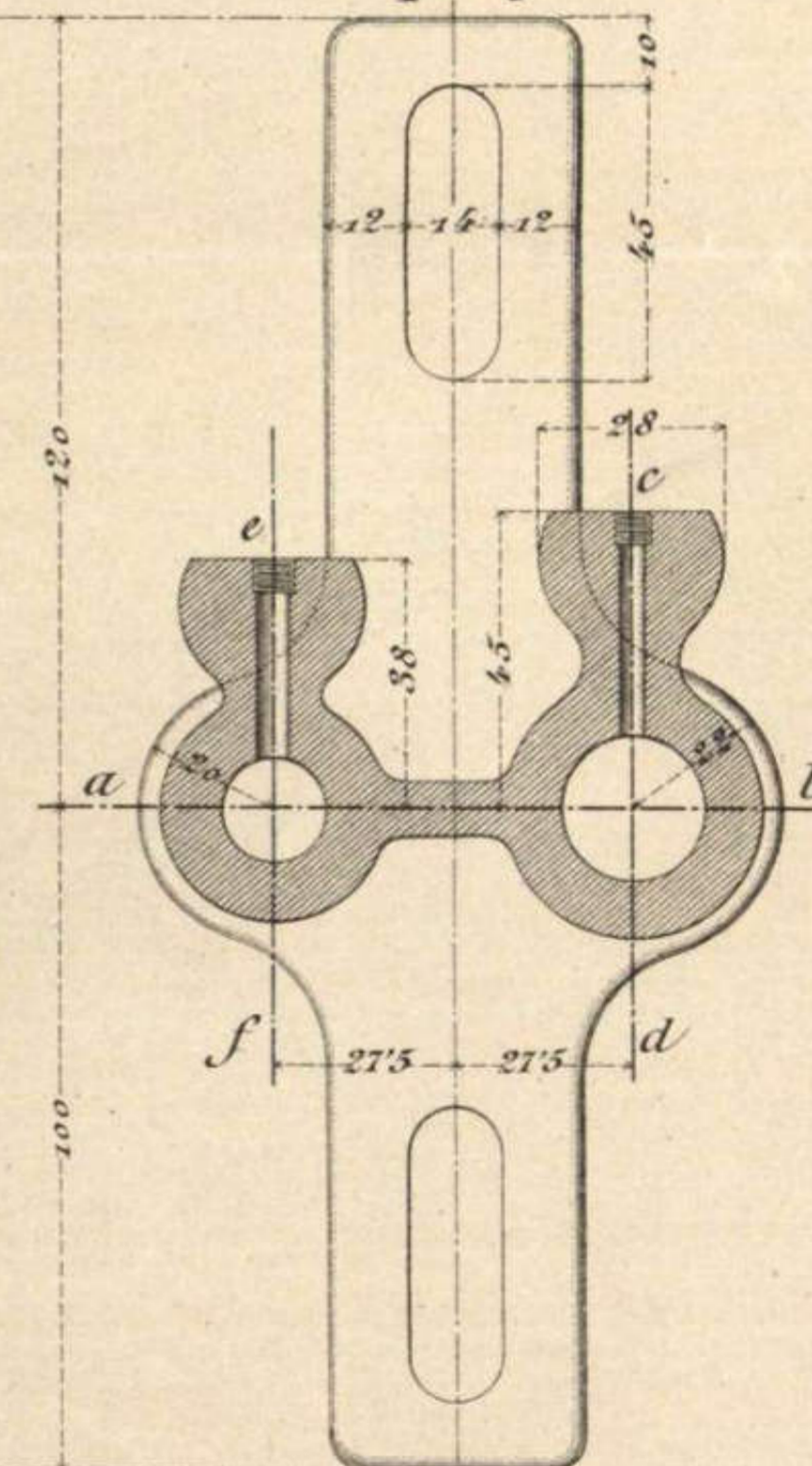

Aparato para sacar la pieza de bateria.

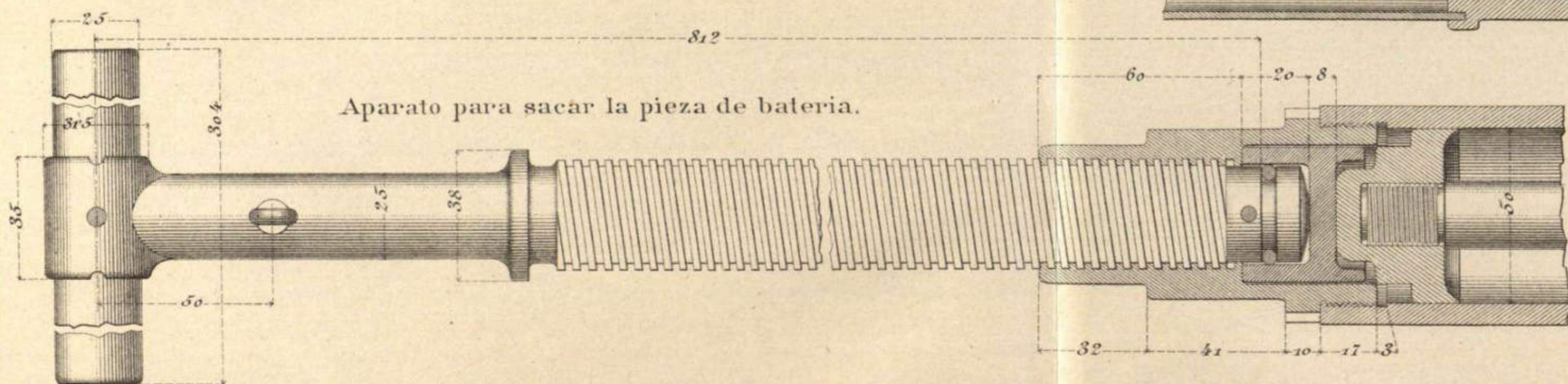

ARMON PARA CAÑON Ac.T.r. DE 7'5 cm. DE CAMPAÑA M.d. 1906.

VISTA VERTICAL

Escala $\frac{1}{10}$.

Escala $\frac{1}{10}$

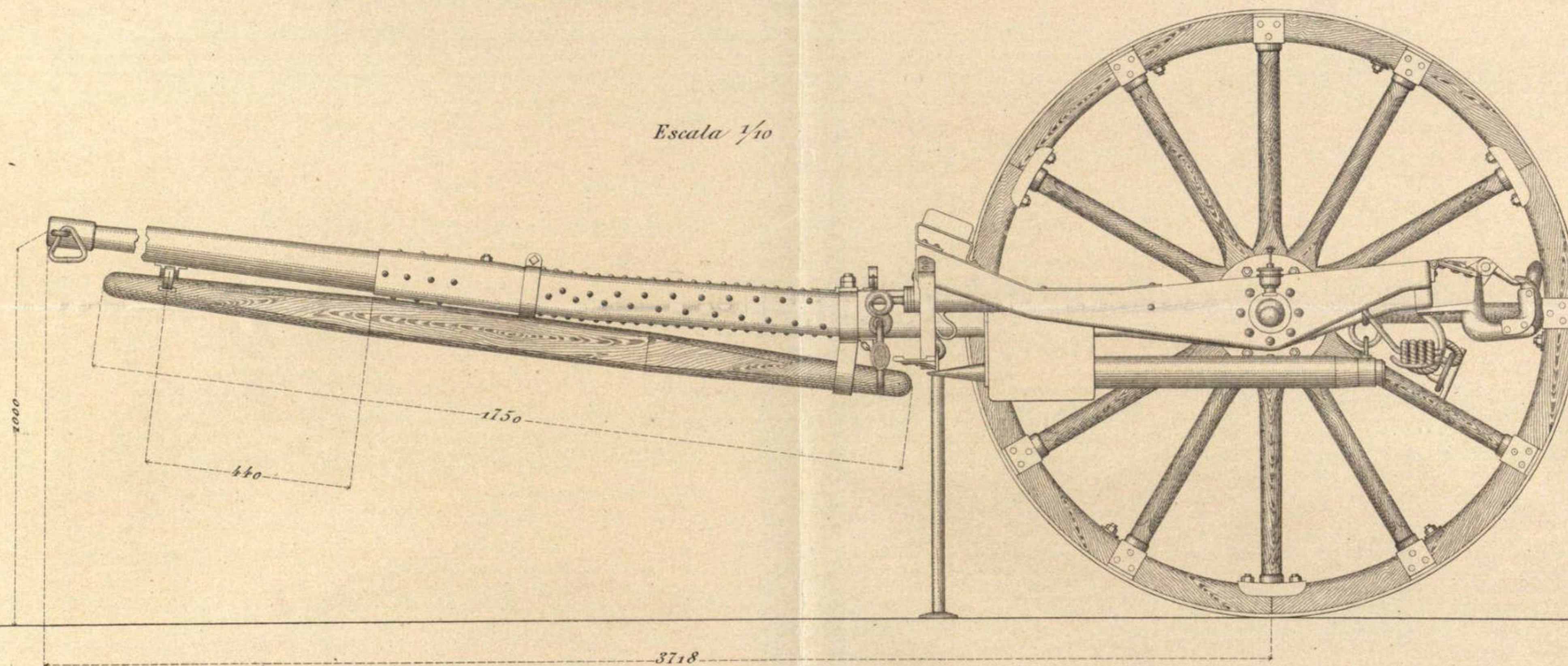

ARMON PARA CAÑON Ac.T.r. DE 7'5 cm. DE CAMPAÑA M.d. 1906.

VISTA HORIZONTAL

Escala $\frac{1}{10}$.

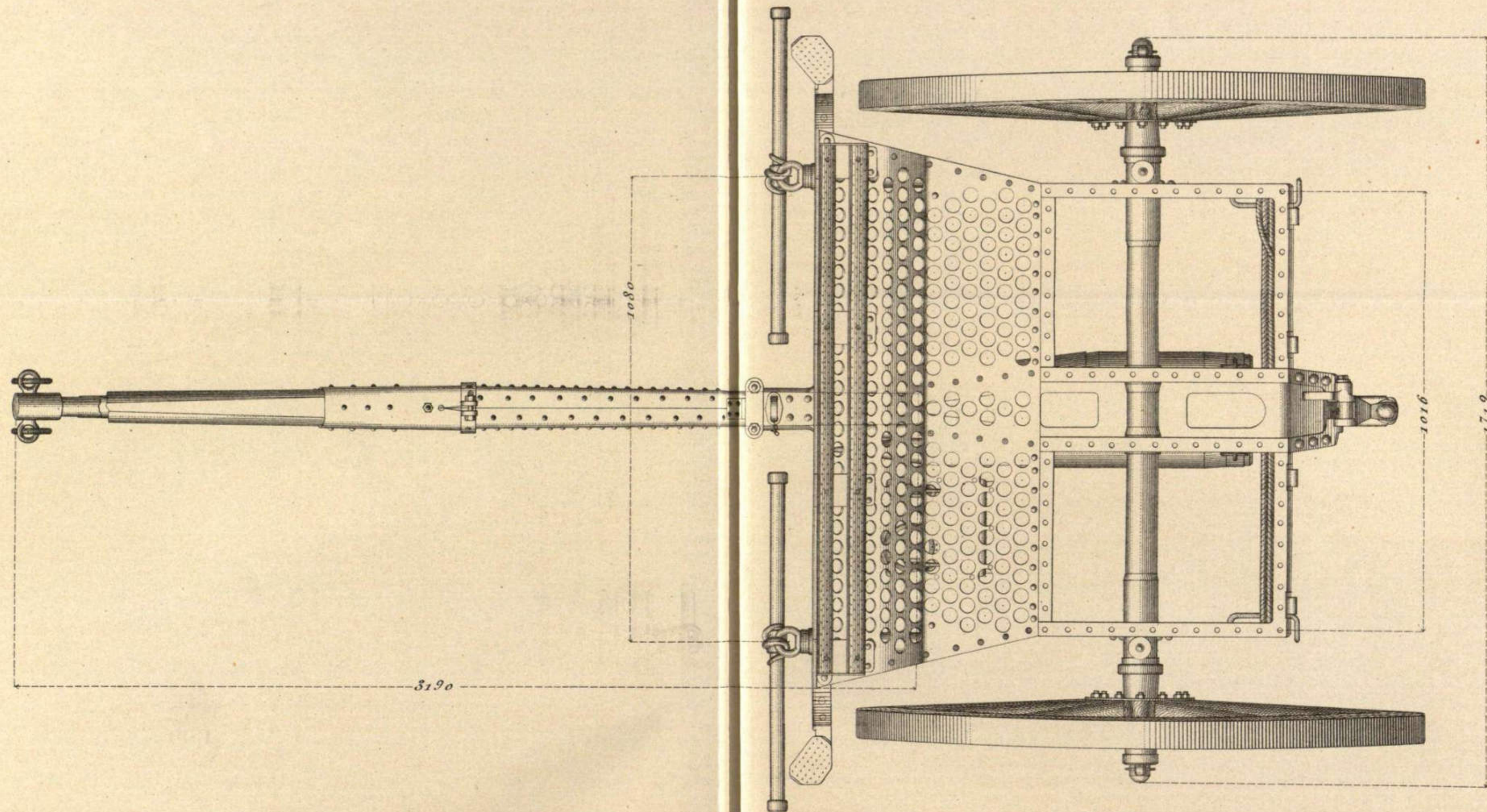

ARMON PARA CAÑON Ac. Tr. DE 7' 5 cm. DE CAMPAÑA Md. 1906.

Escala 1/10

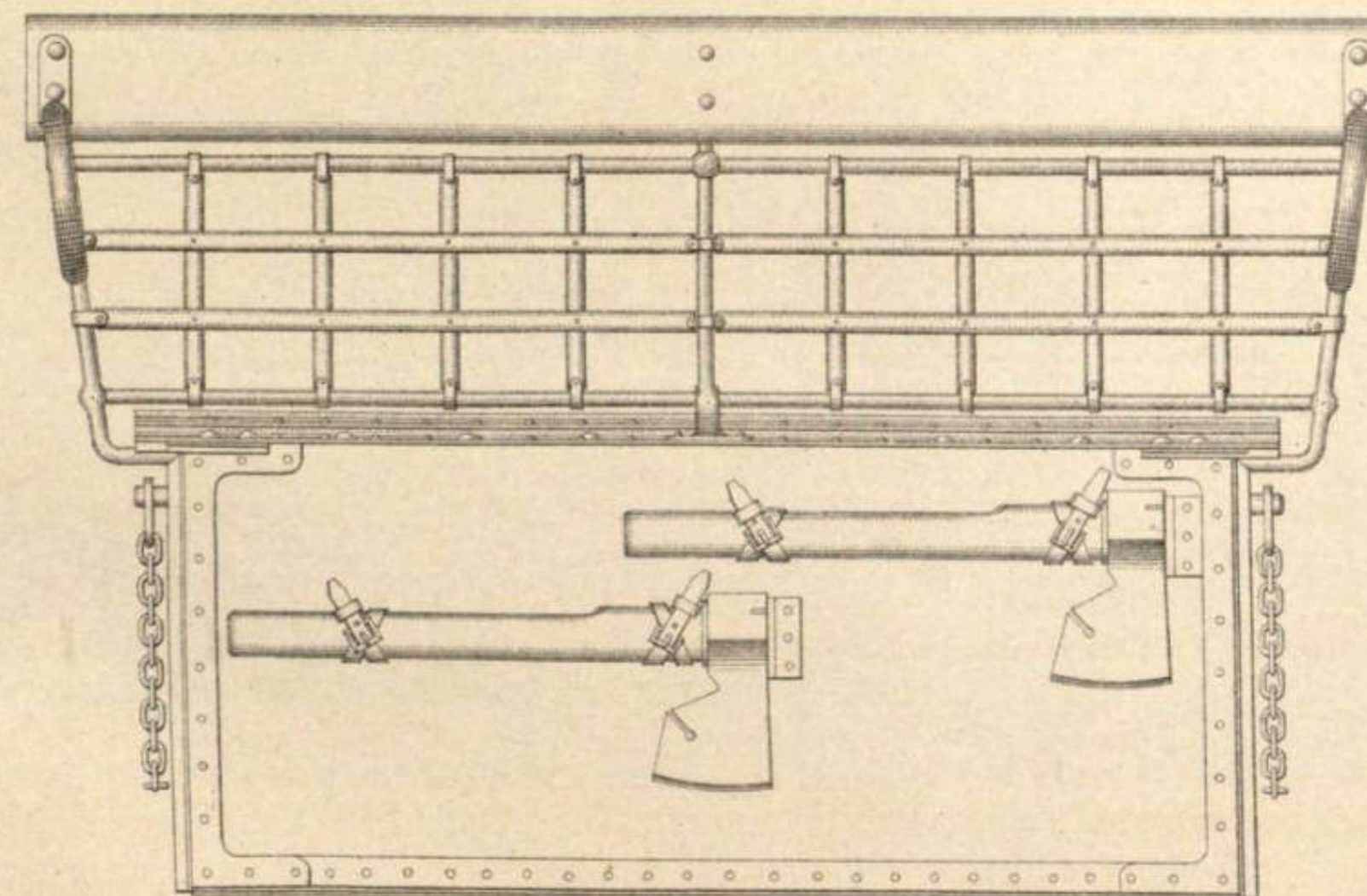
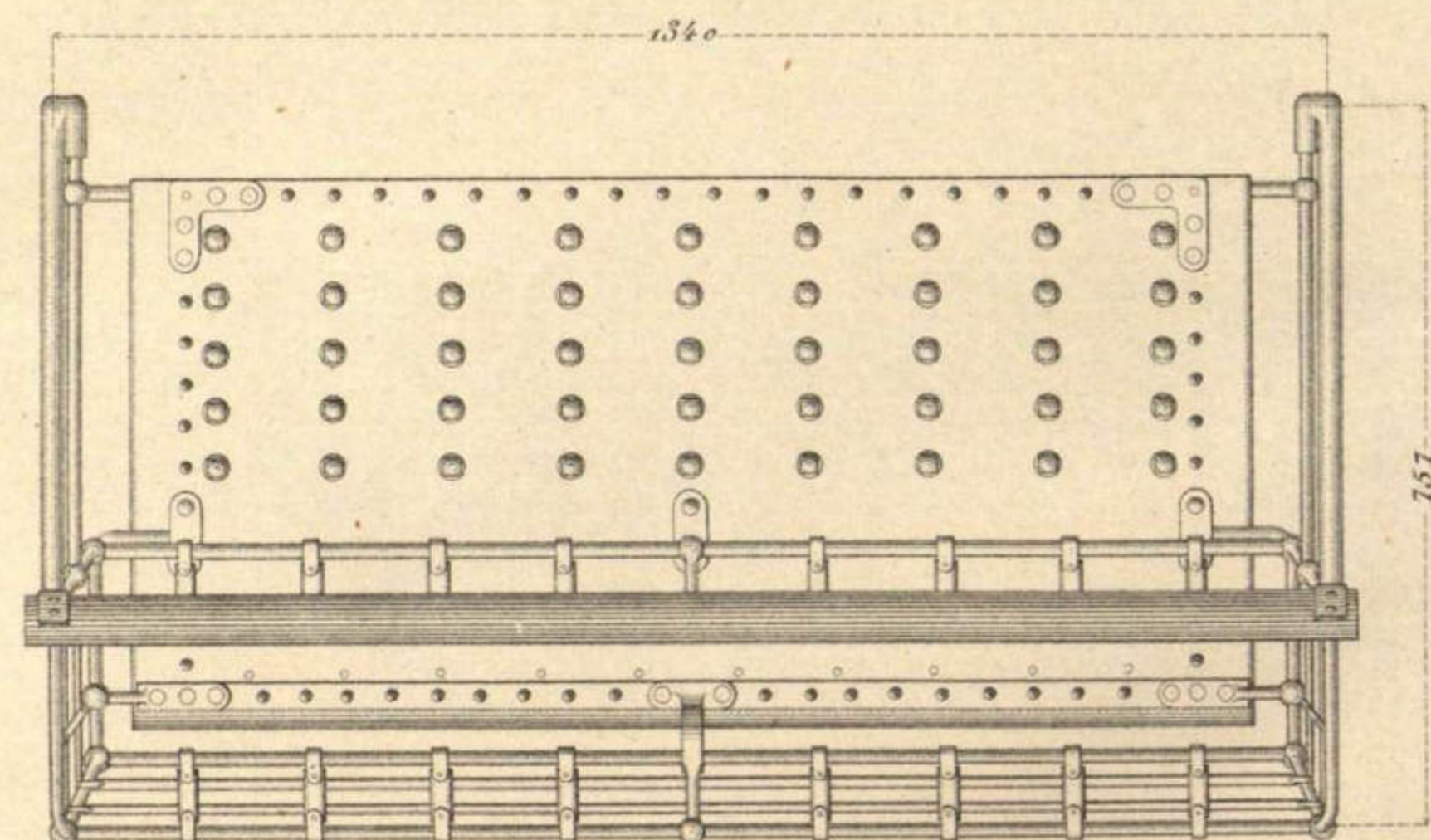
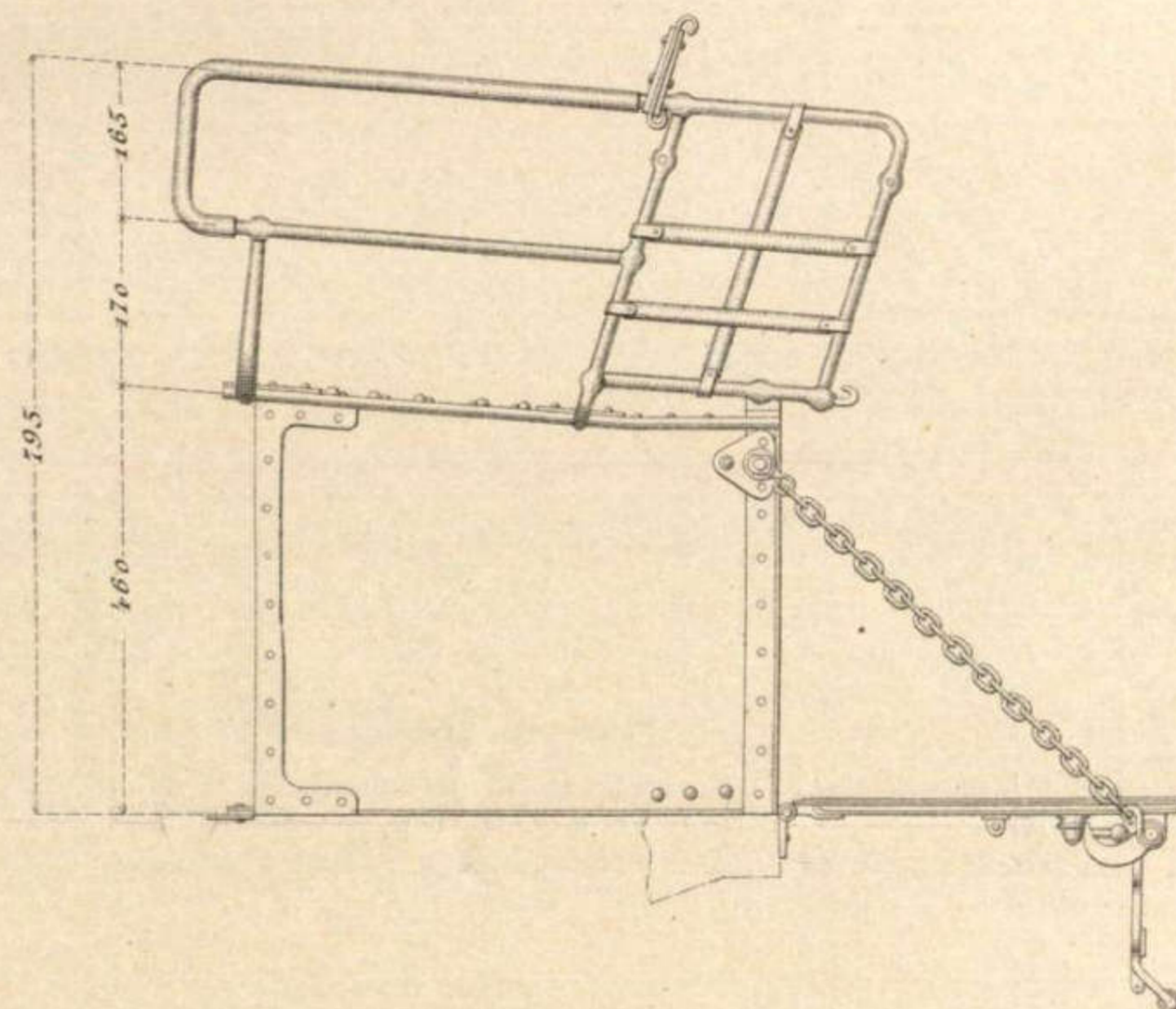
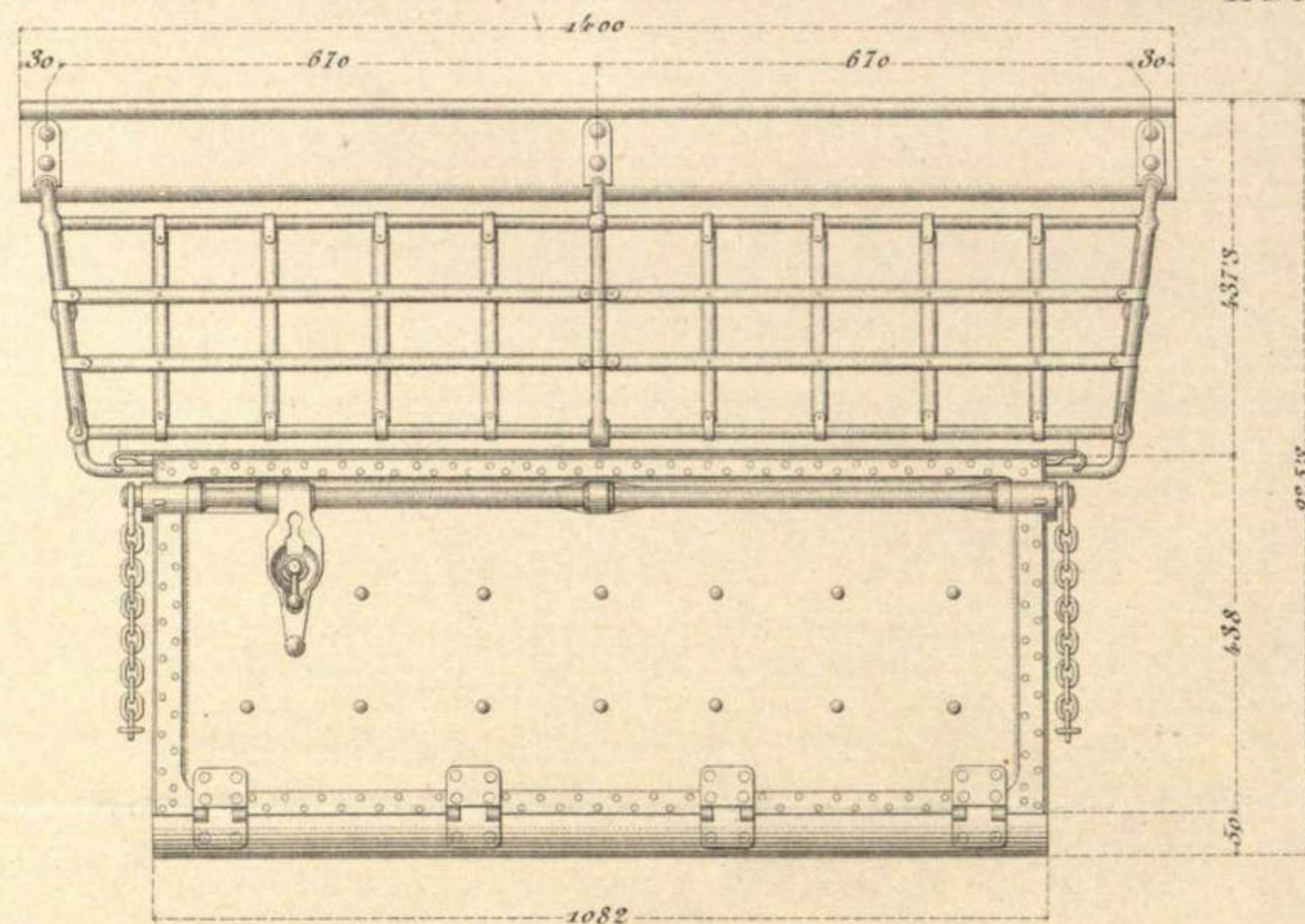

ARMON PARA CAÑON Ac. Tr. DE 7' 5 cm. DE CAMPAÑA Md. 1906.

Eje. (E. = 3/10.)

Acero.

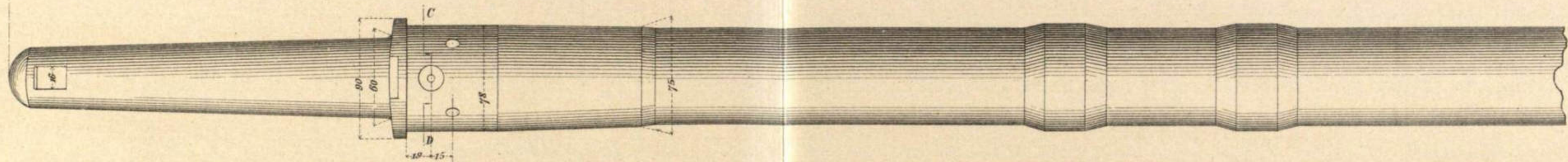
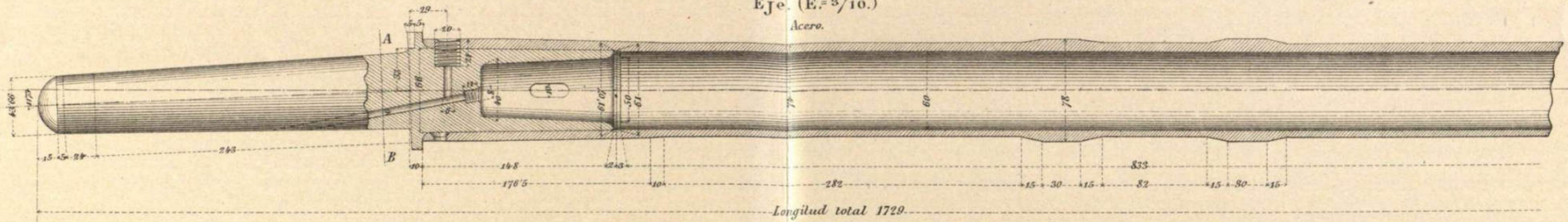

Corte por A.B.

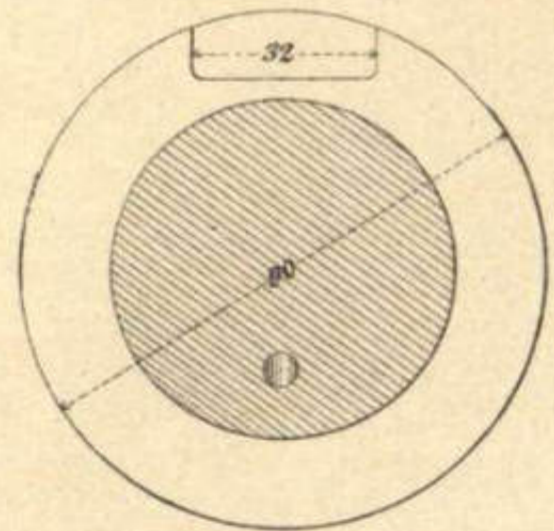

Corte por C.D.

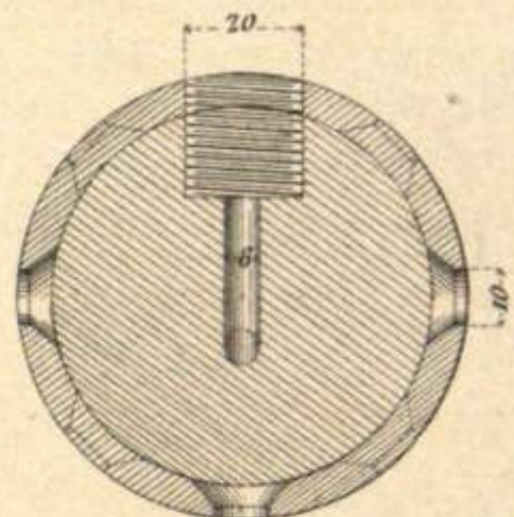

2 Engrasadores.

Bronce

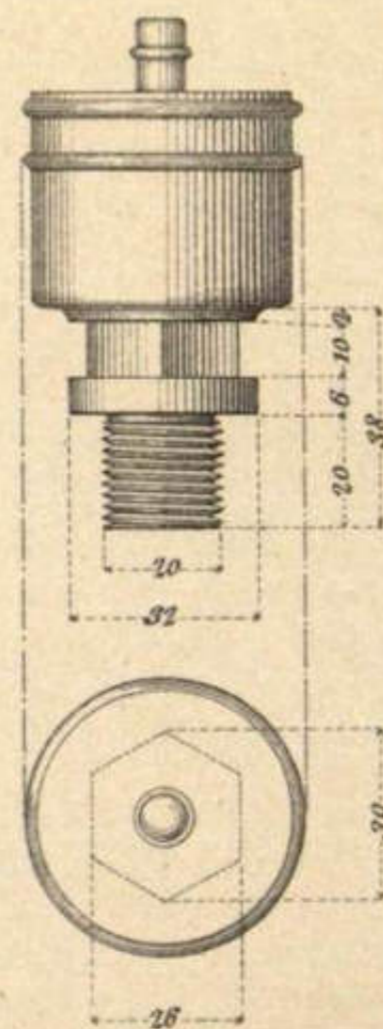

Escala 5/10.

2 Cáncamos para enganche de los balancines.

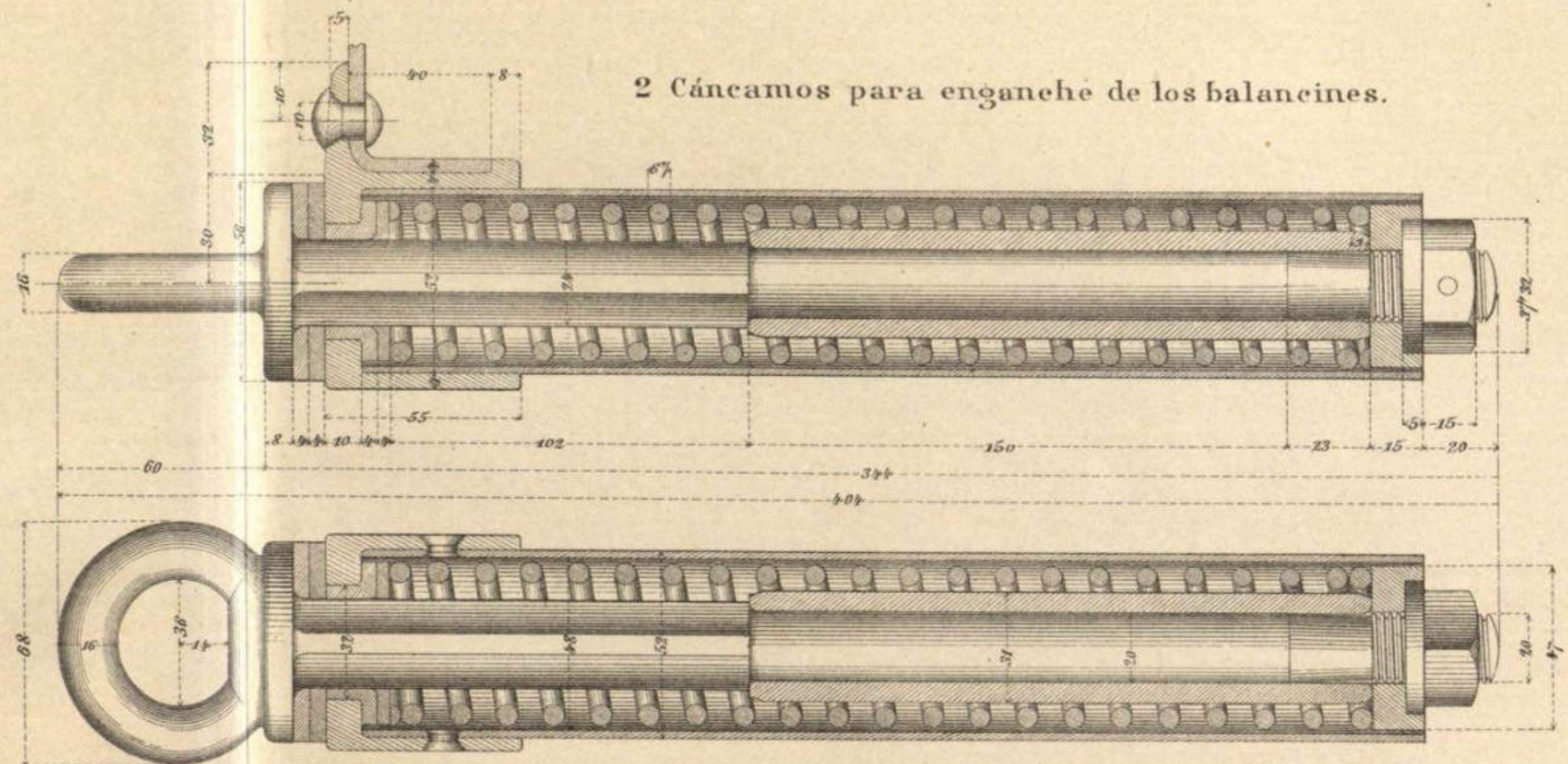

ARMON PARA CAÑÓN Ac. T. r. DE 7' 5 cm. DE CAMPAÑA Md. 1906.

LANZA

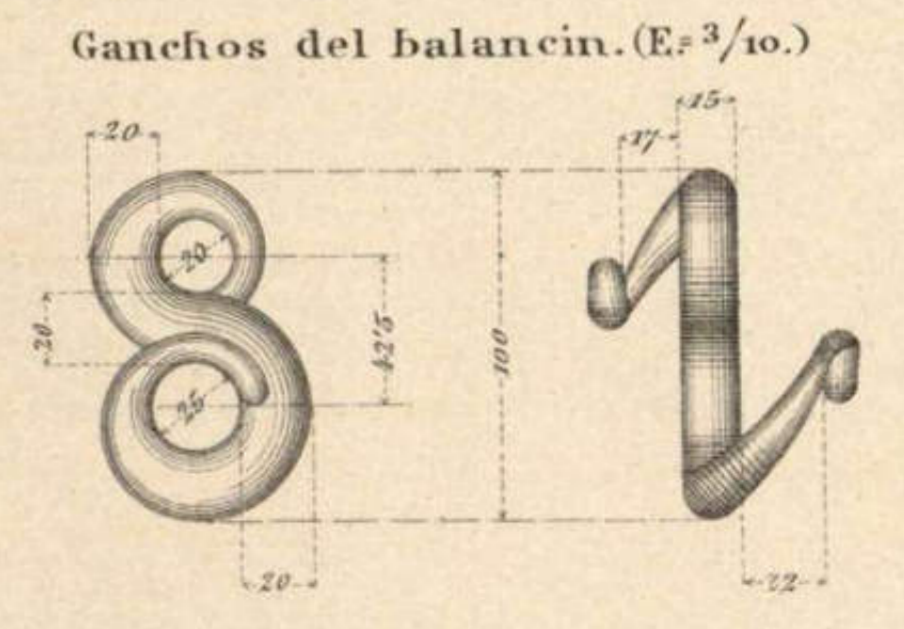
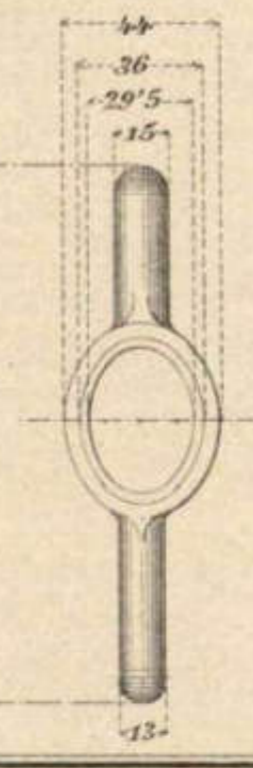
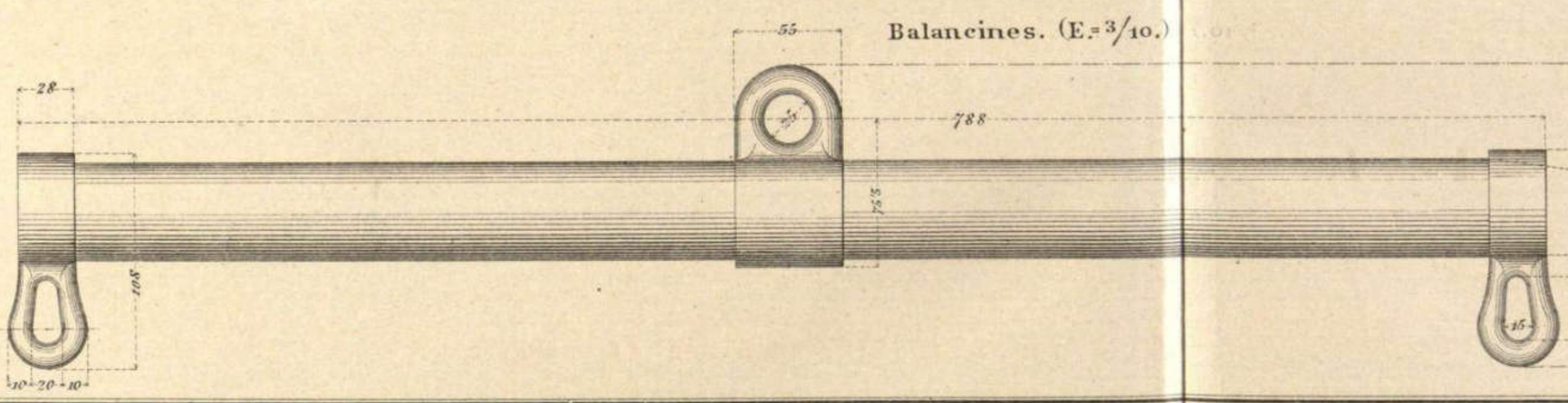
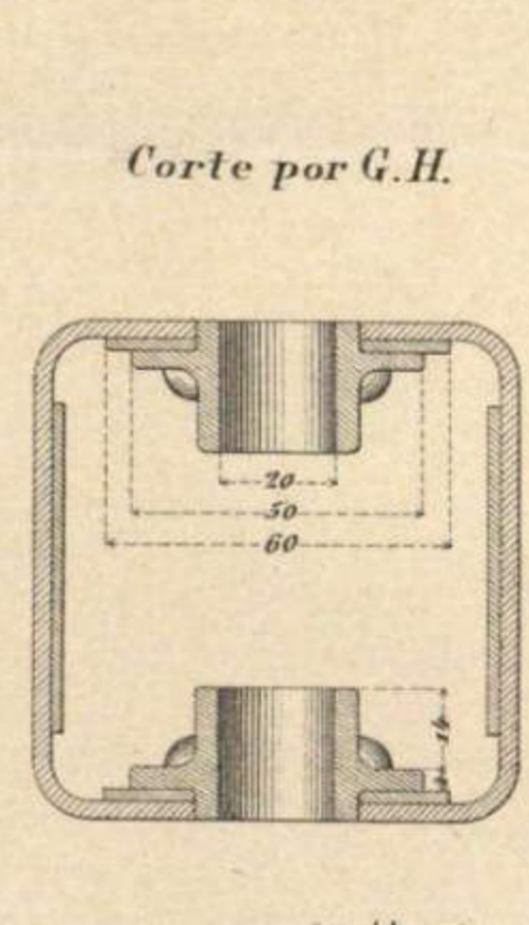
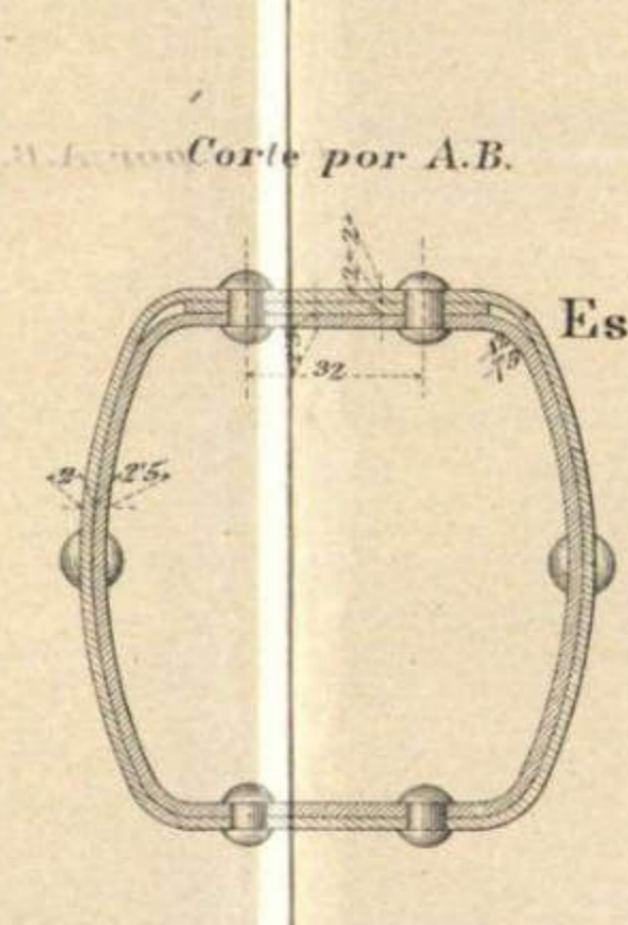
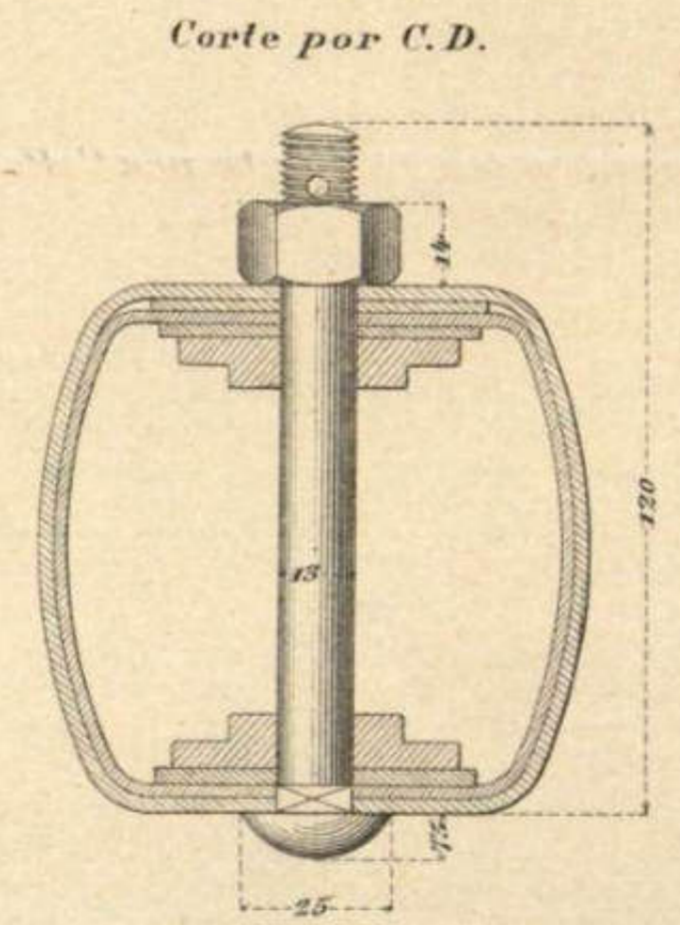
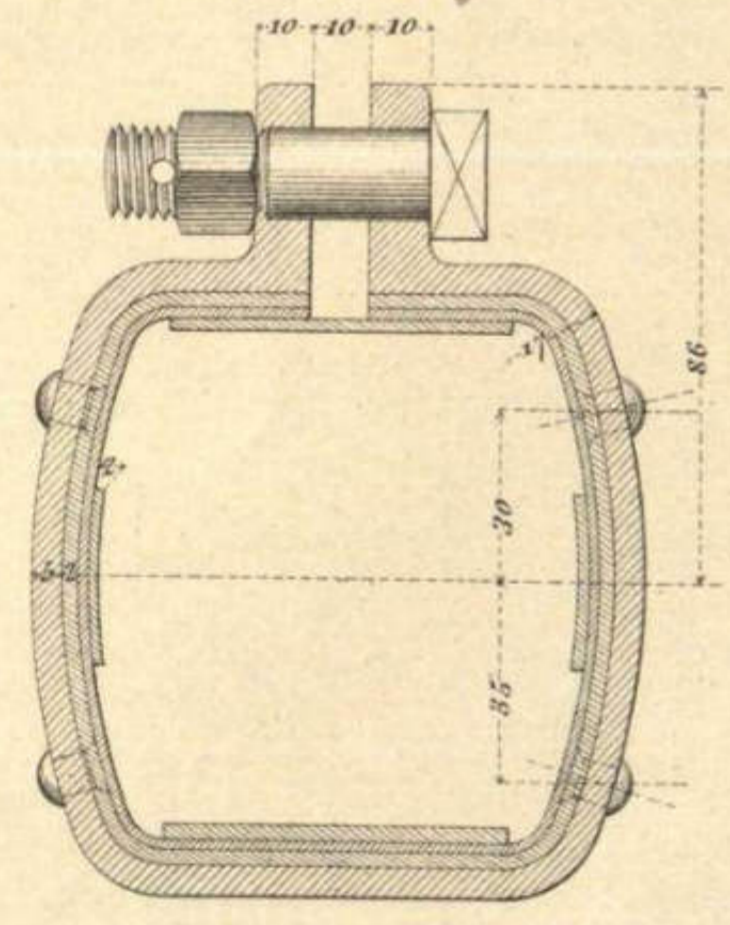
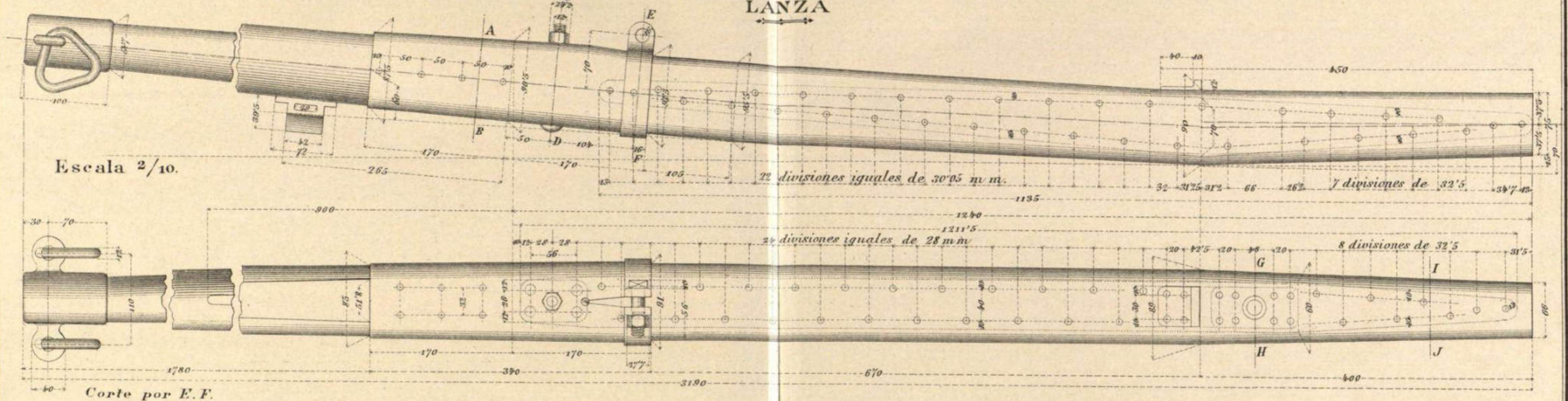

CARRO PARA CAÑON Ac.T.r. DE 7'5 cm. DE CAMPAÑA M.d. 1906.

VISTA VERTICAL

Escala 1/10.

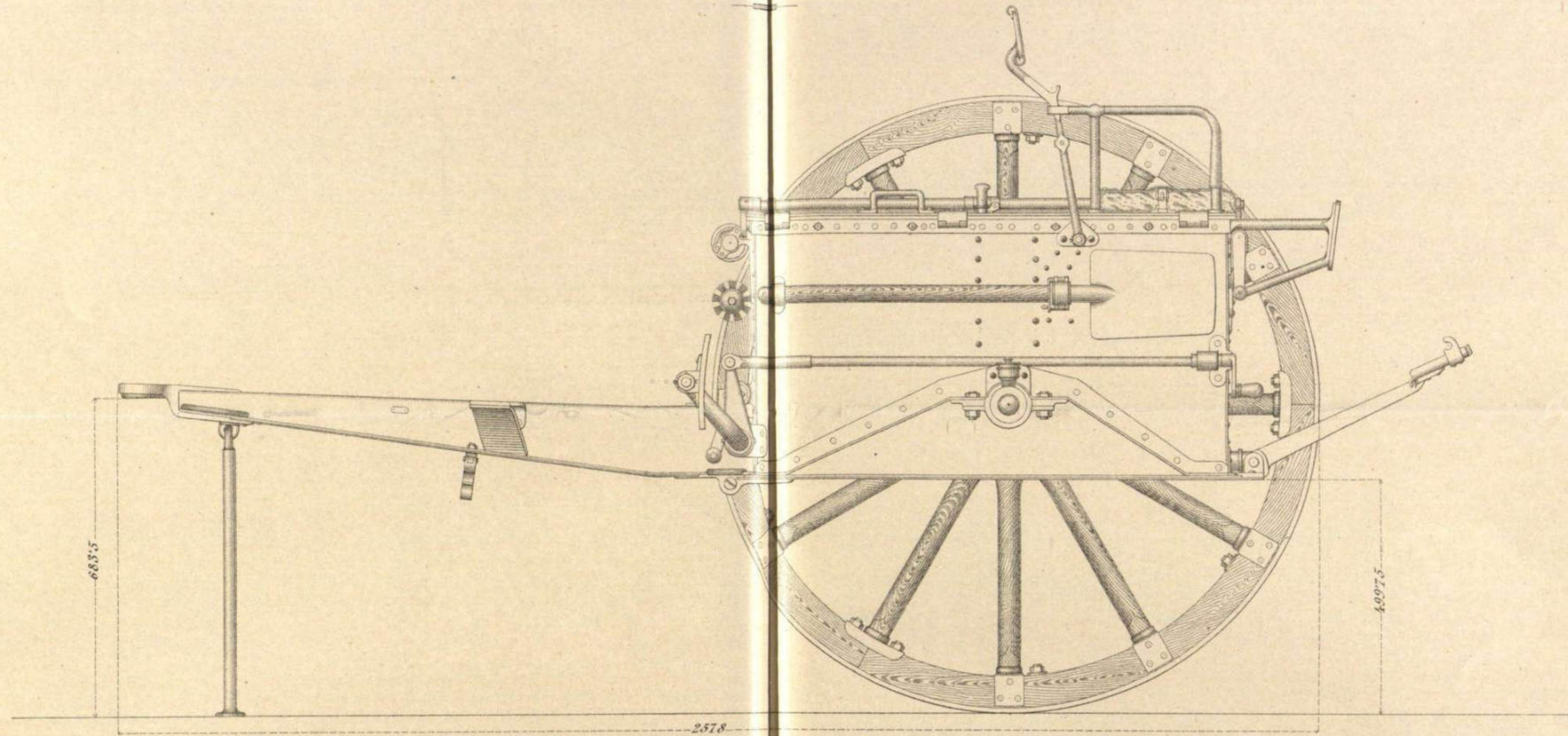

CARRO PARA CAÑÓN Ac.Tr. DE 7'5 cm. DE CAMPAÑA Md. 1906.

VISTA HORIZONTAL

Escala $\frac{1}{10}$.

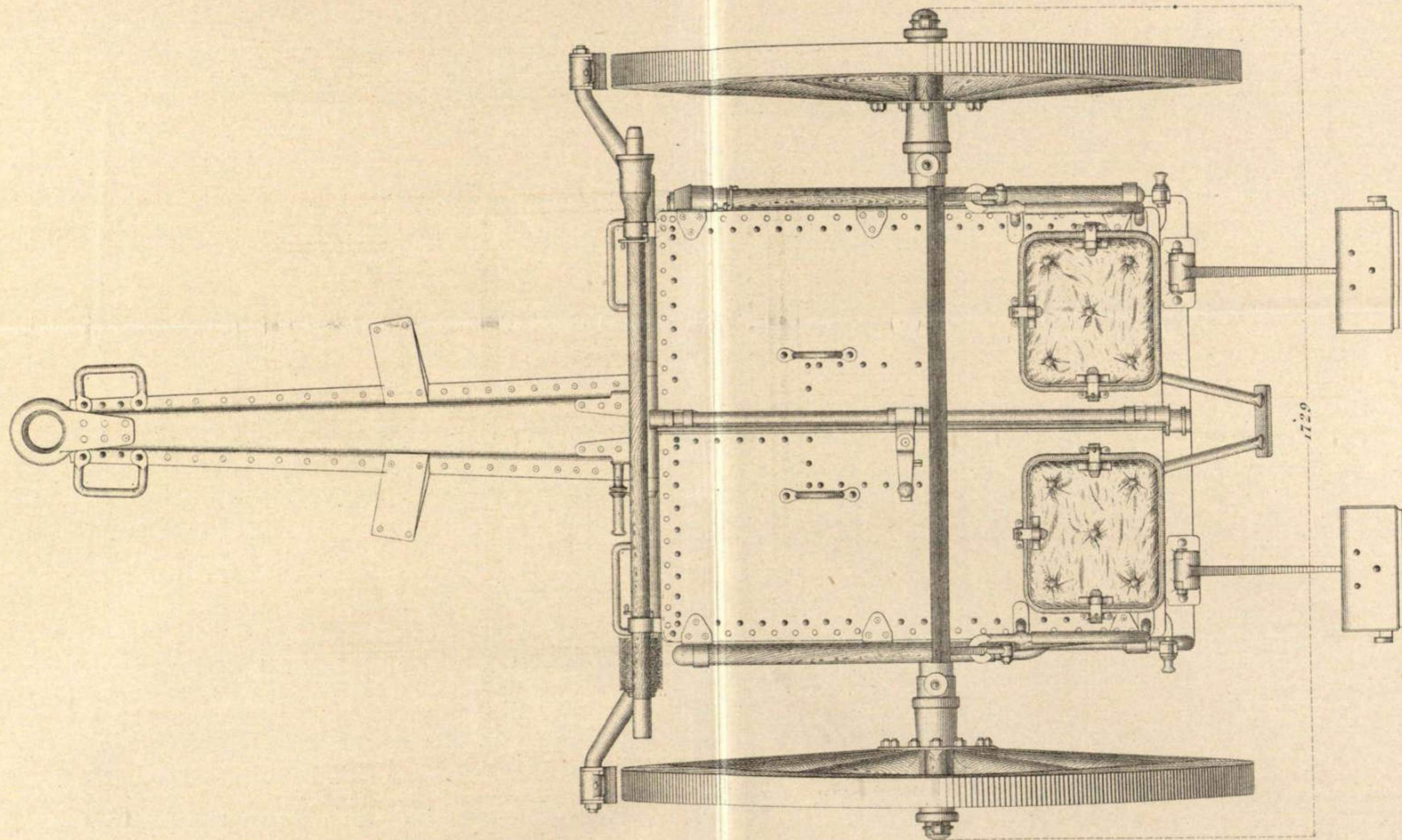

CARRO PARA CAÑON Ac. T. r. DE 7' 5 cm. DE CAMPAÑA Md. 1906.

FRENO DE MARCHIA

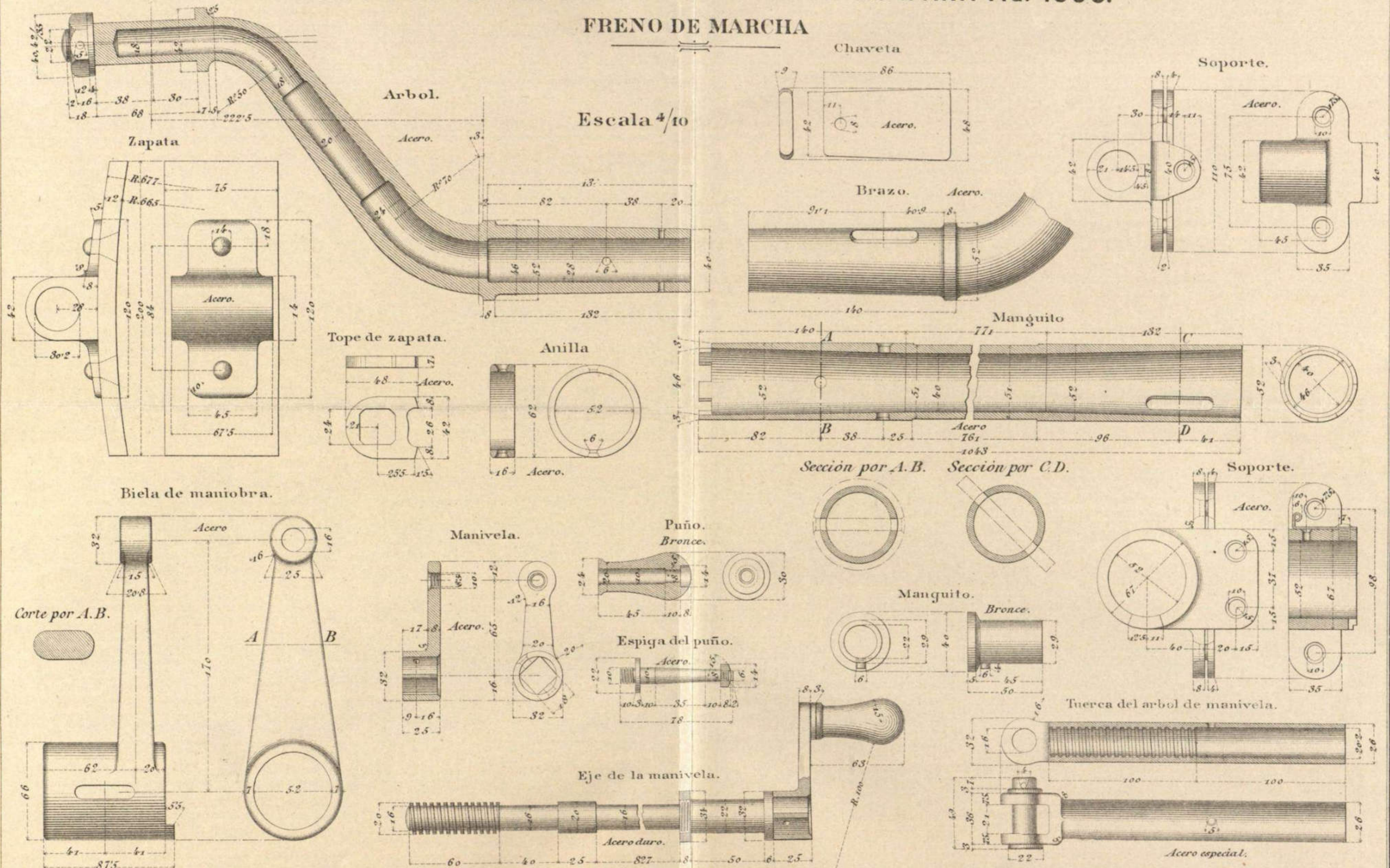

CARRO PARA CAÑÓN Ac. Tr. DE 7'5 cm. DE CAMPAÑA Md. 1906. CAJAS DE ACCESORIOS, REPUESTOS Y ÚTILES

Escala 1/5

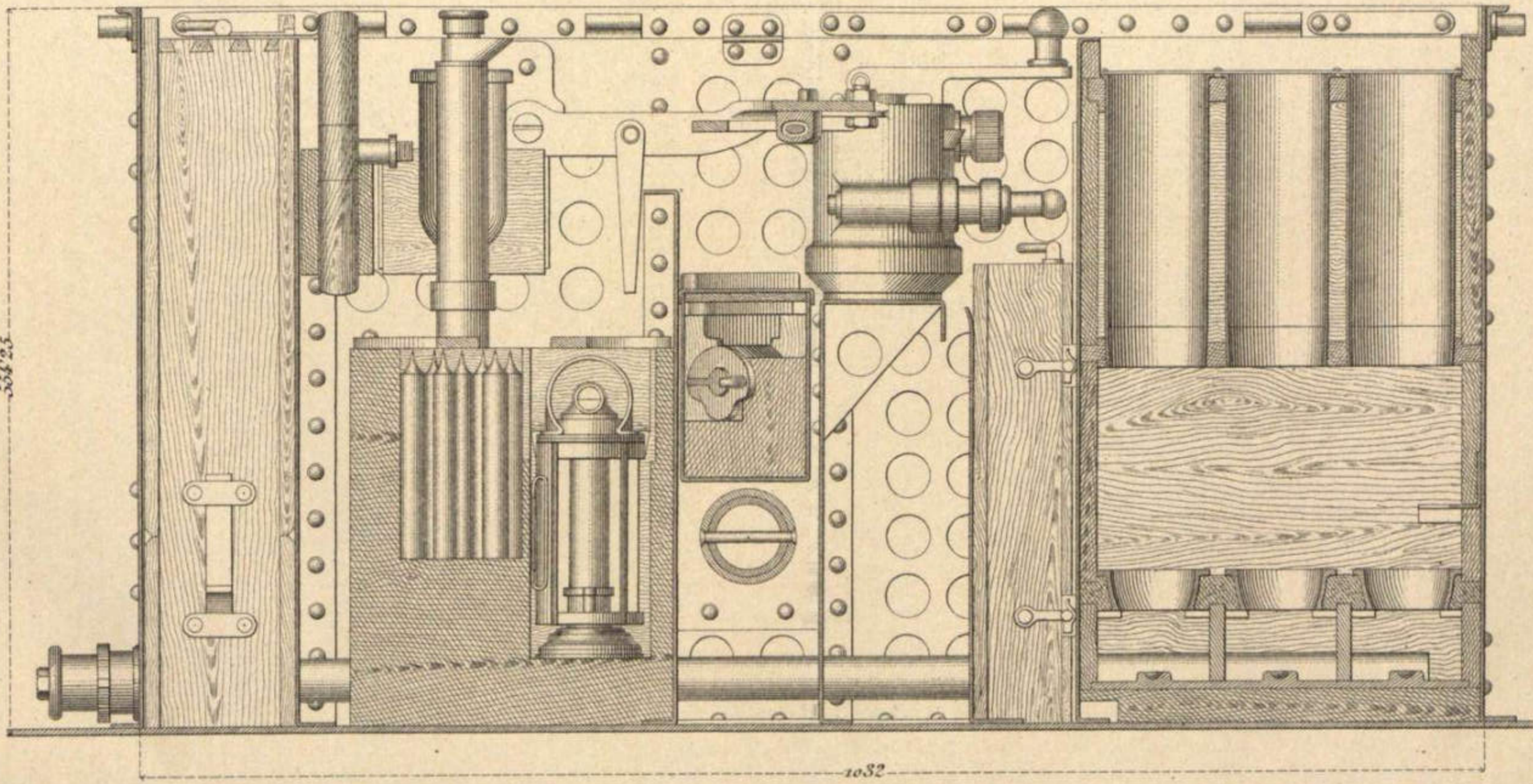

Escala 1/10

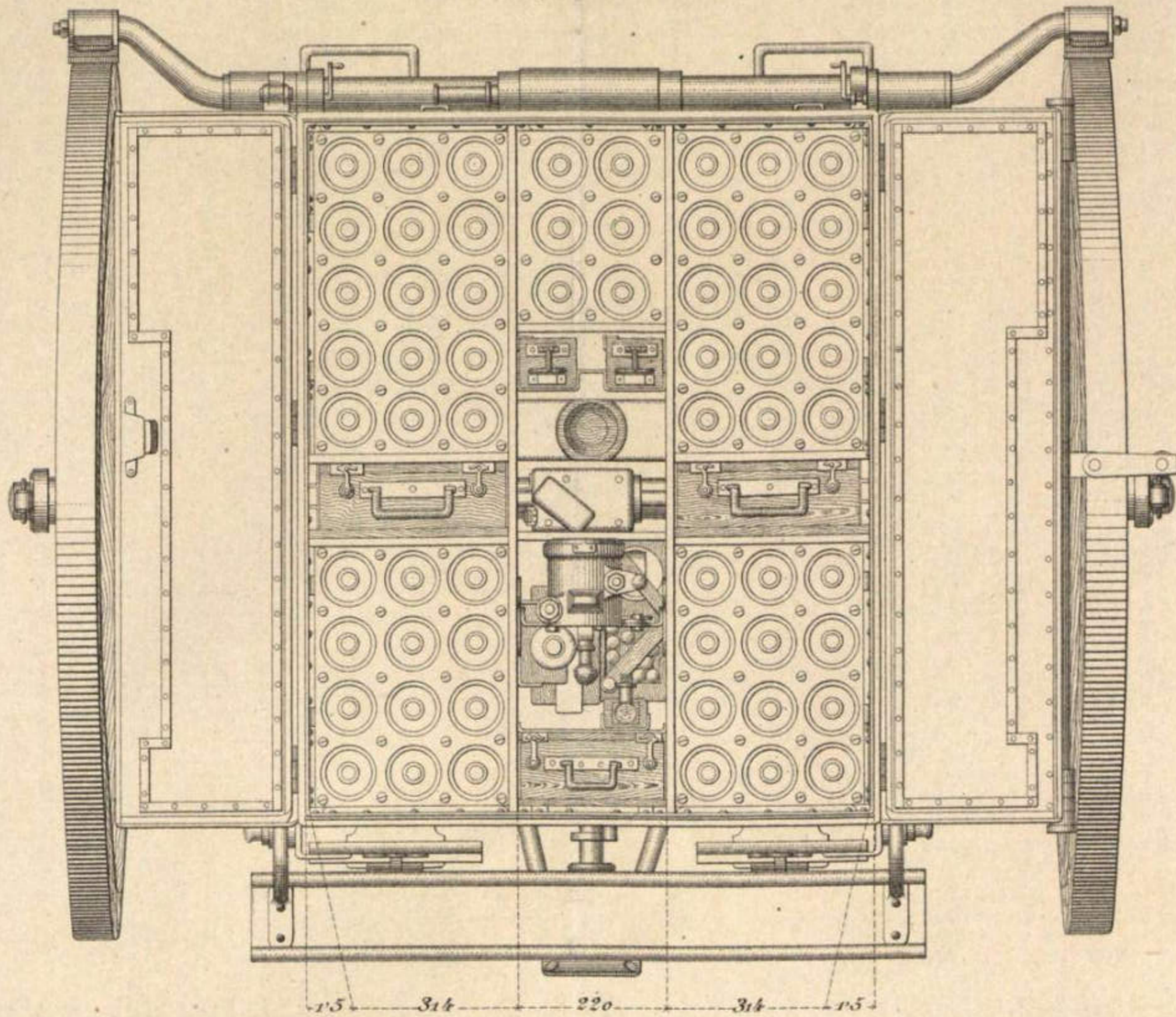

CARRO PARA CAÑÓN Ac.T.r. DE 7'5 cm. DE CAMPAÑA Md. 1906.

DISTRIBUCIÓN DE LAS CAJAS EN EL CARRO DE GRANADAS ROMPEDORAS

Escala 2/10.

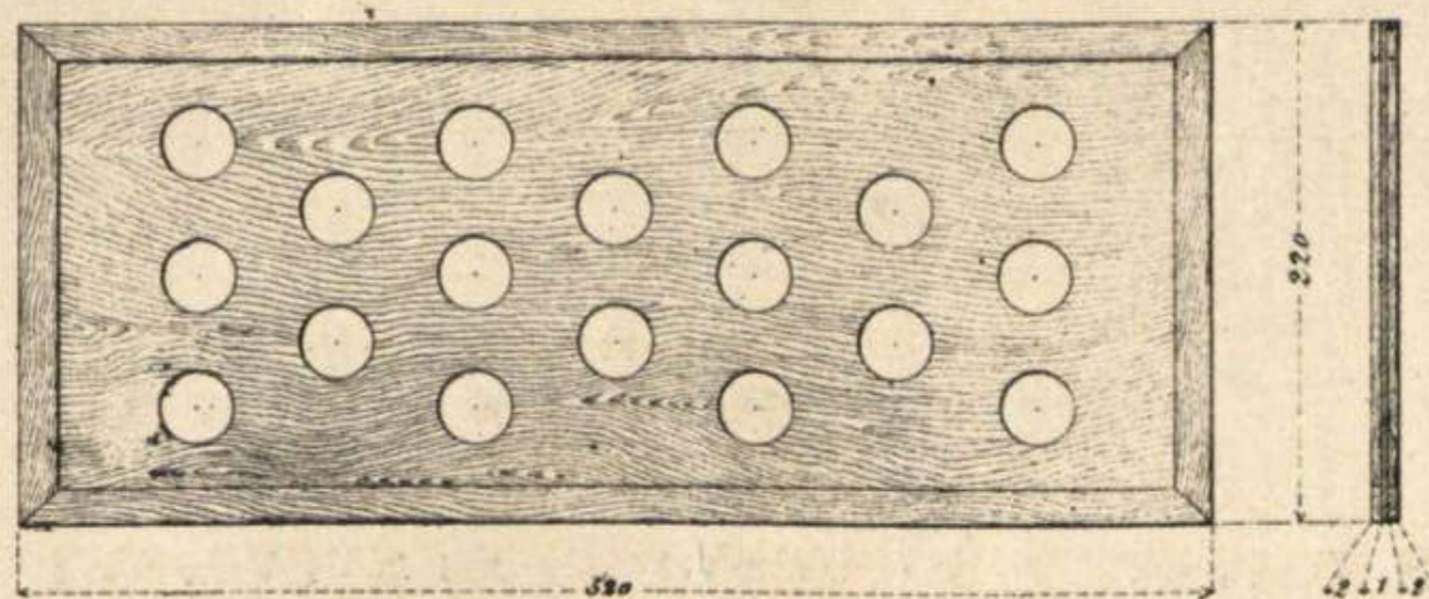
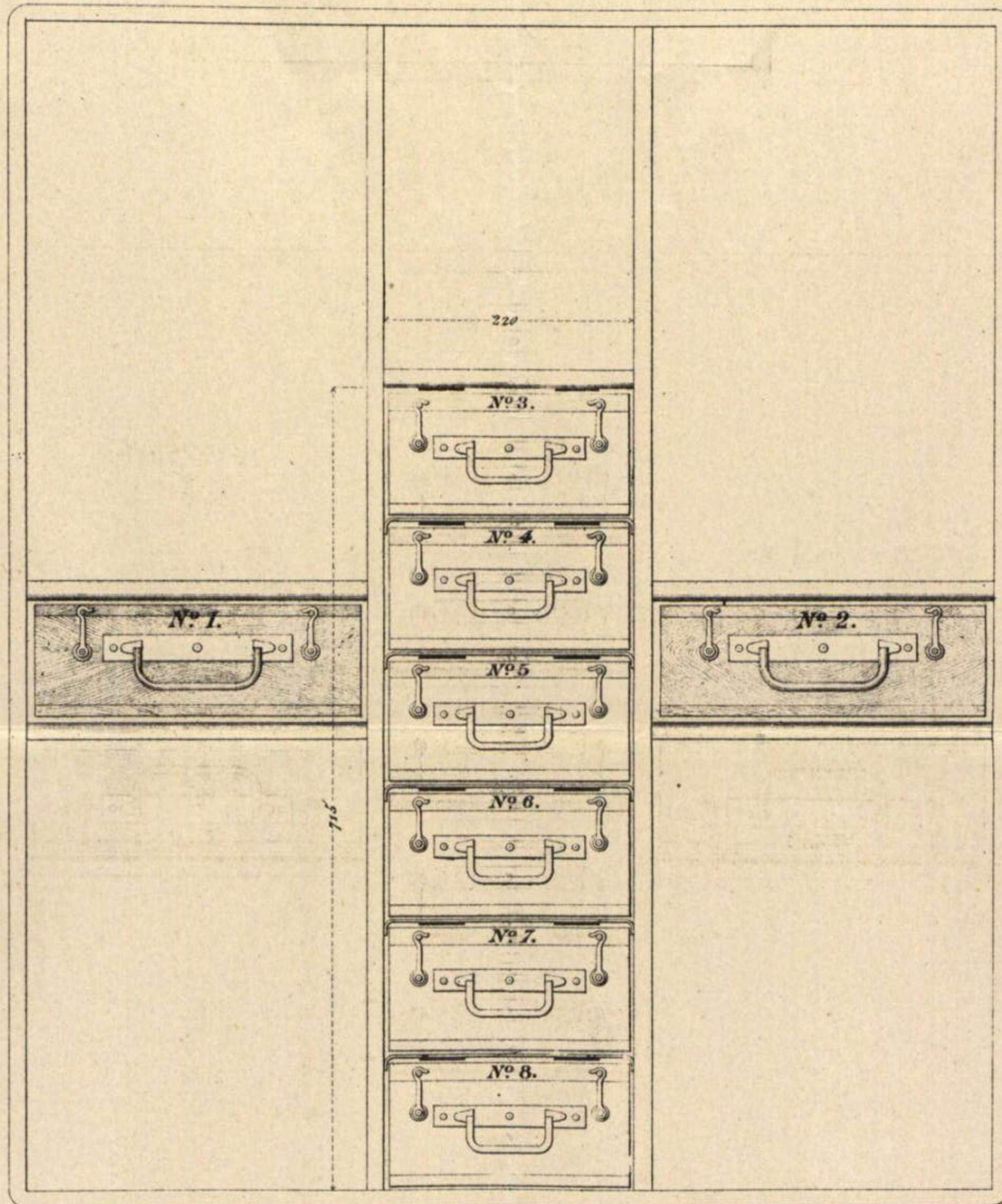

CARRO PARA CAÑÓN Ac. T. r. DE 7'5 cm. DE CAMPAÑA Md. 1906.

DISTRIBUCIÓN DE LAS CAJAS EN EL CARRO DE GRANADAS ROMPEDORAS

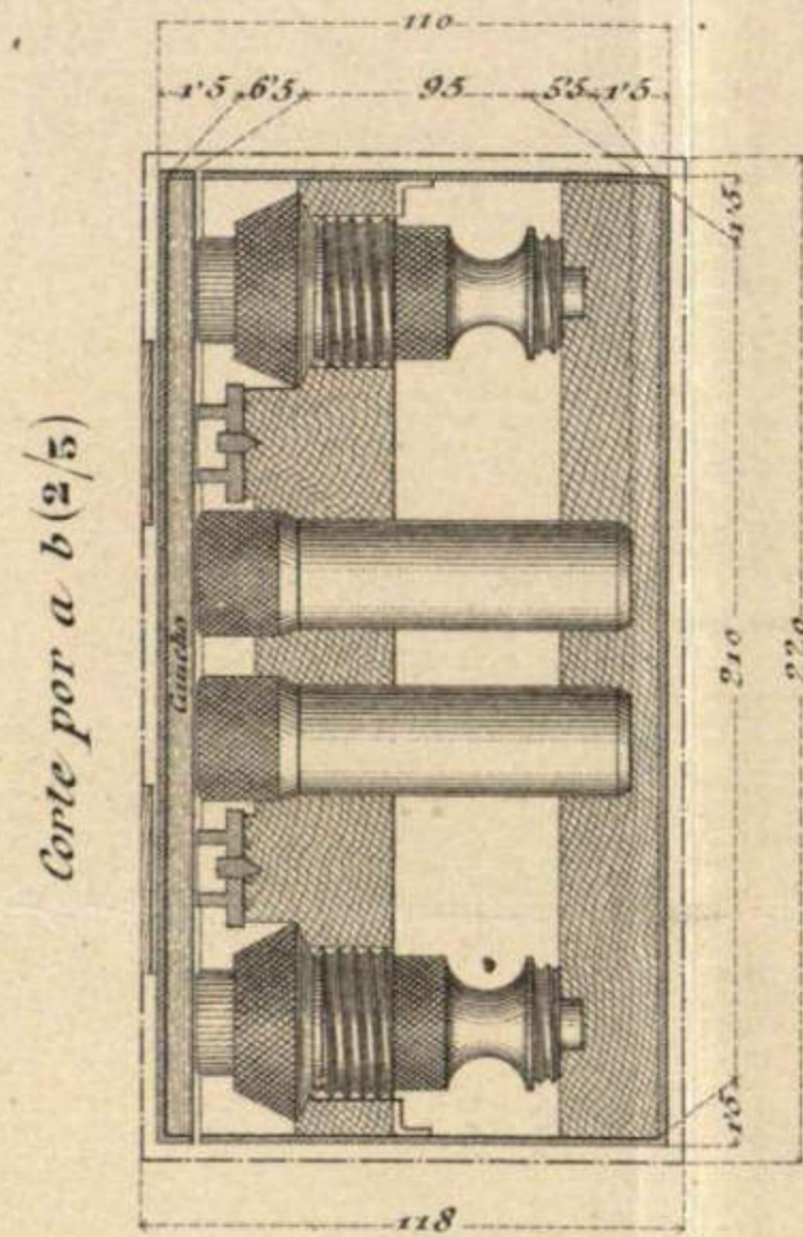
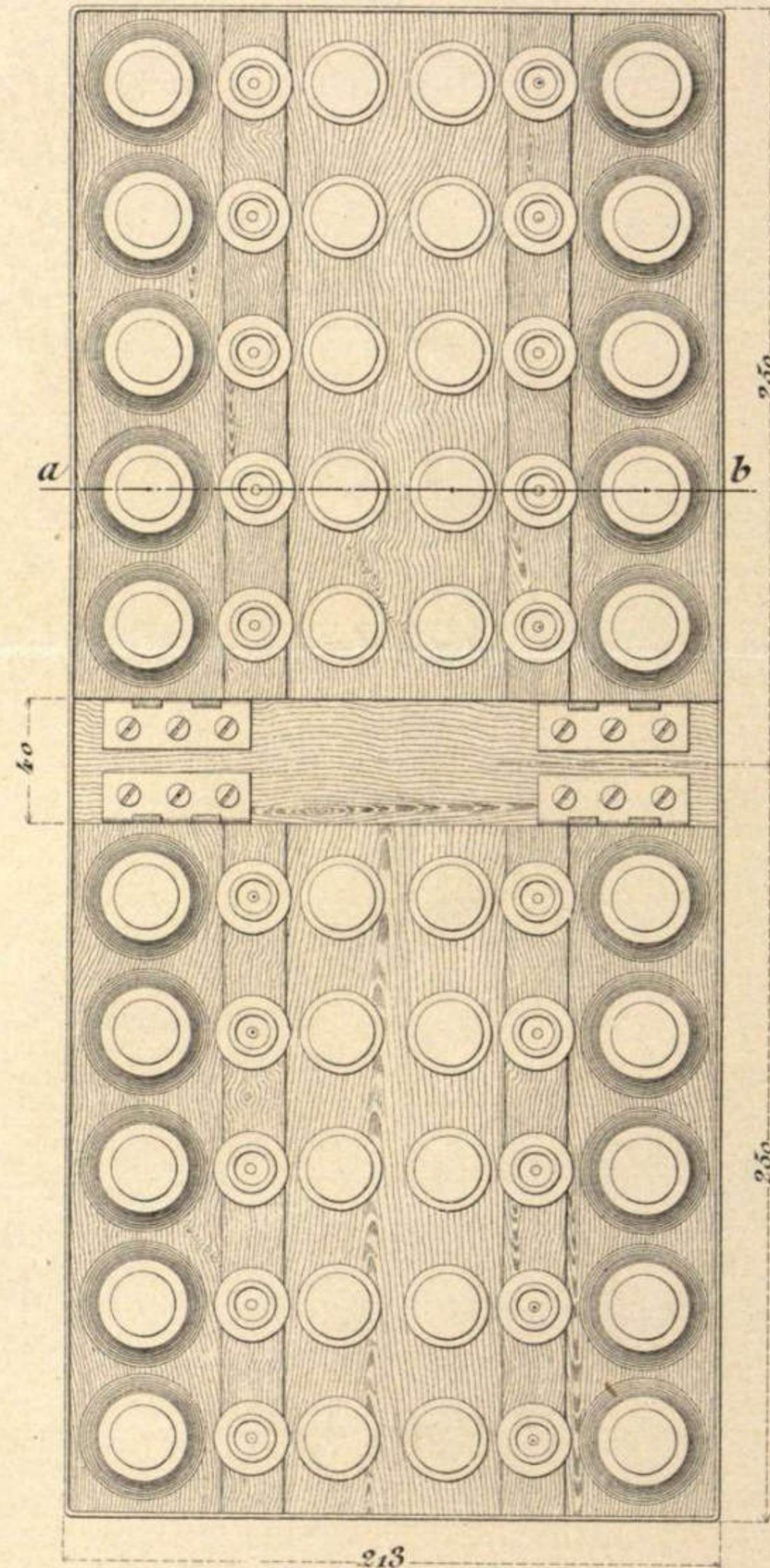

Tapón de corcho para el transporte de las vainas de multiplicador de las ó.r. de Cpa. de 9 y 7'5 cm. y Mña. de 7'5 cm.

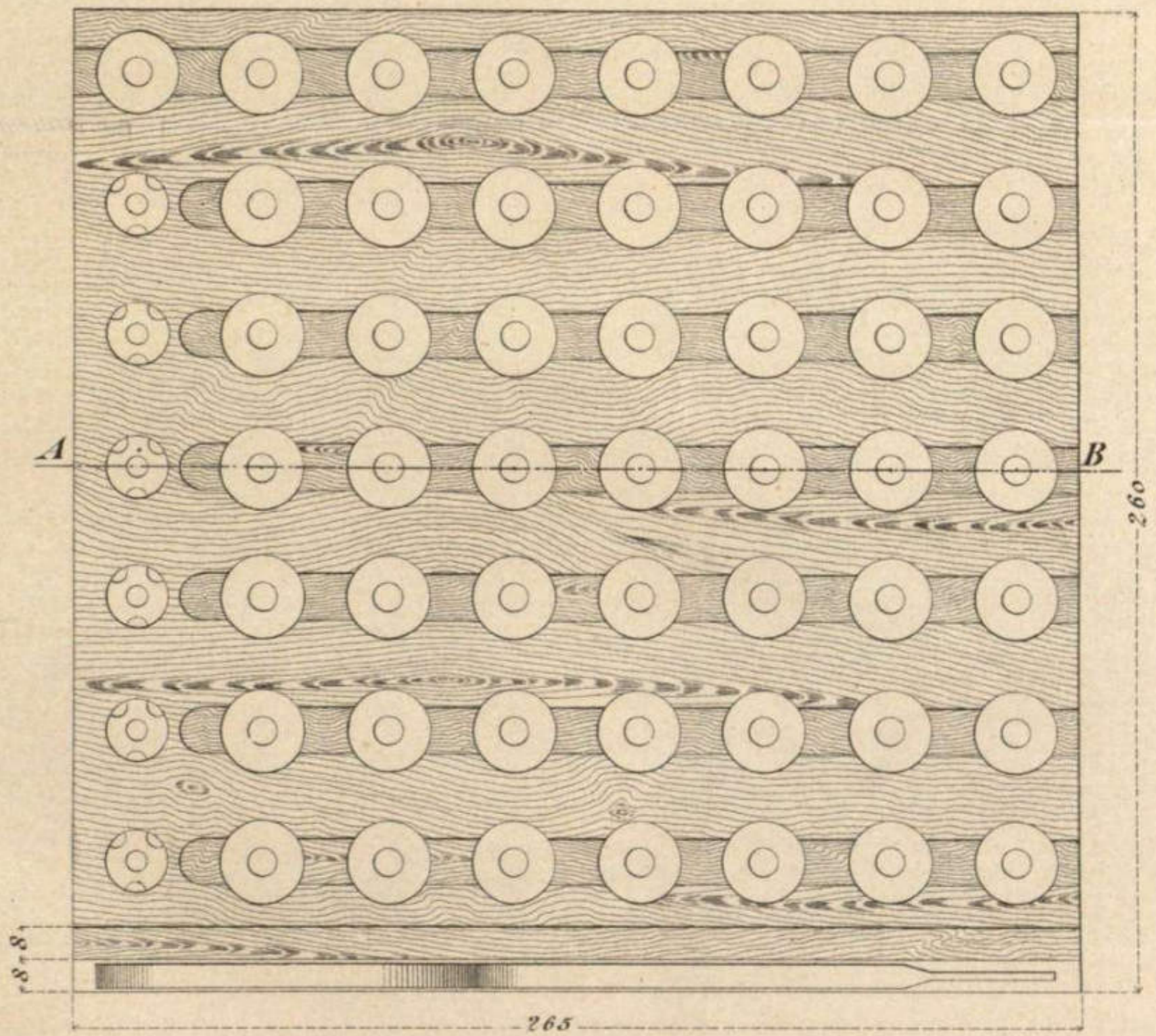
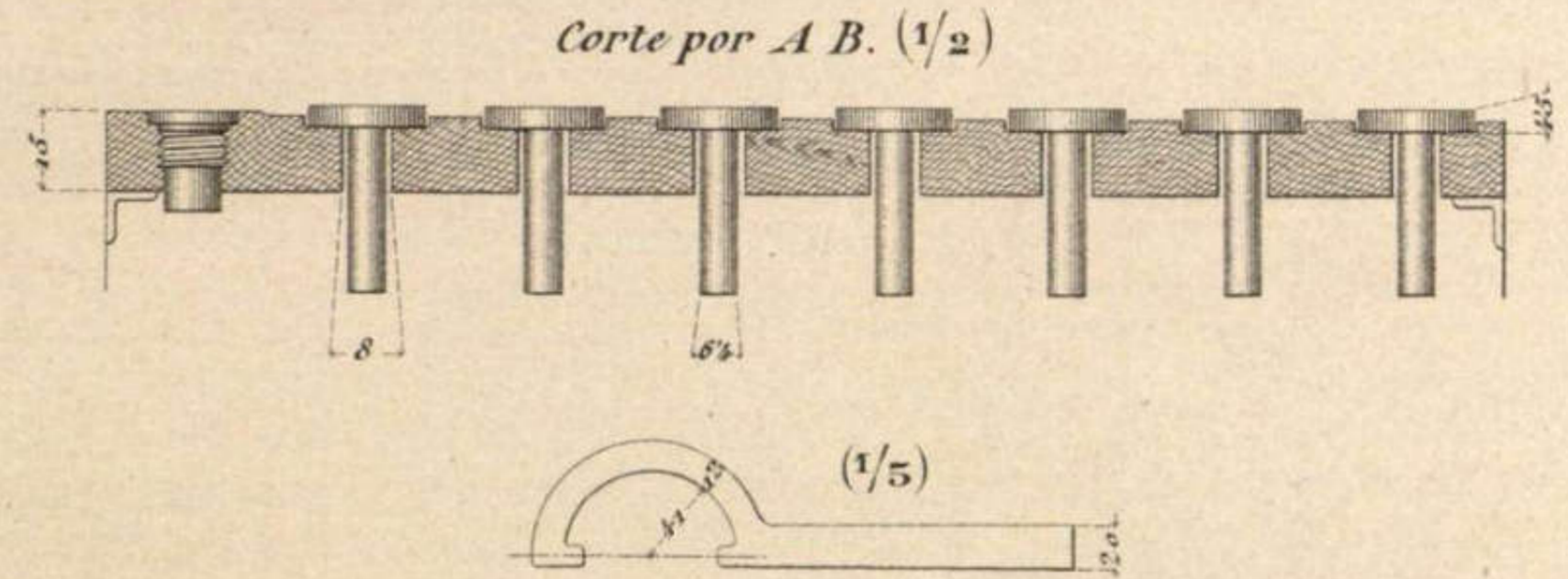
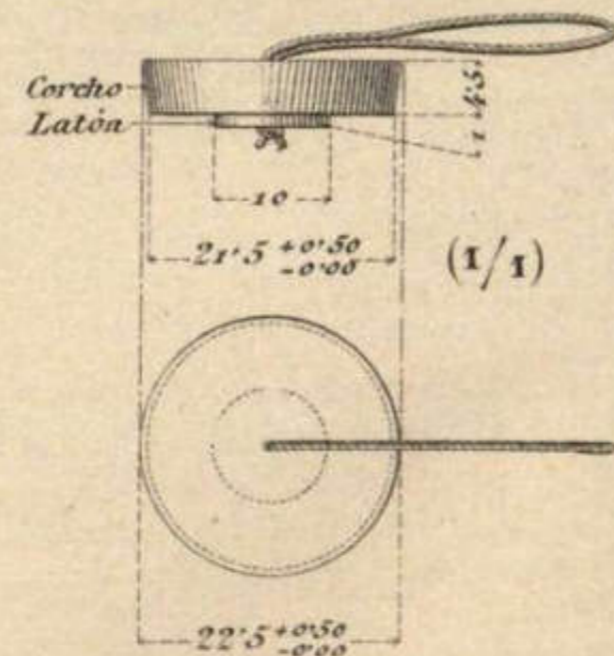

ACCESORIOS PARA EL MATERIAL DE CAMPAÑA Md. 1906.

Escala $\frac{4}{10}$.

Nº 4 Armón de Piezas.

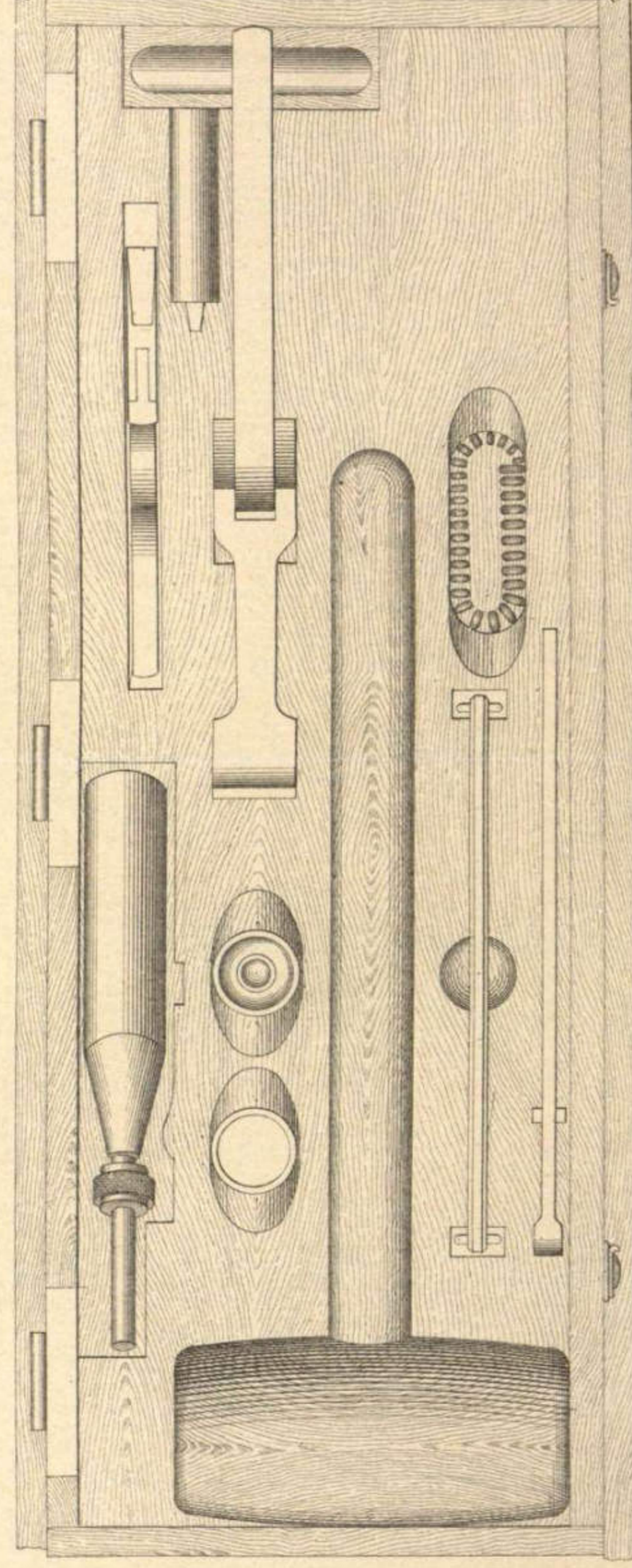

Nº 1 Retrotren de Carro.

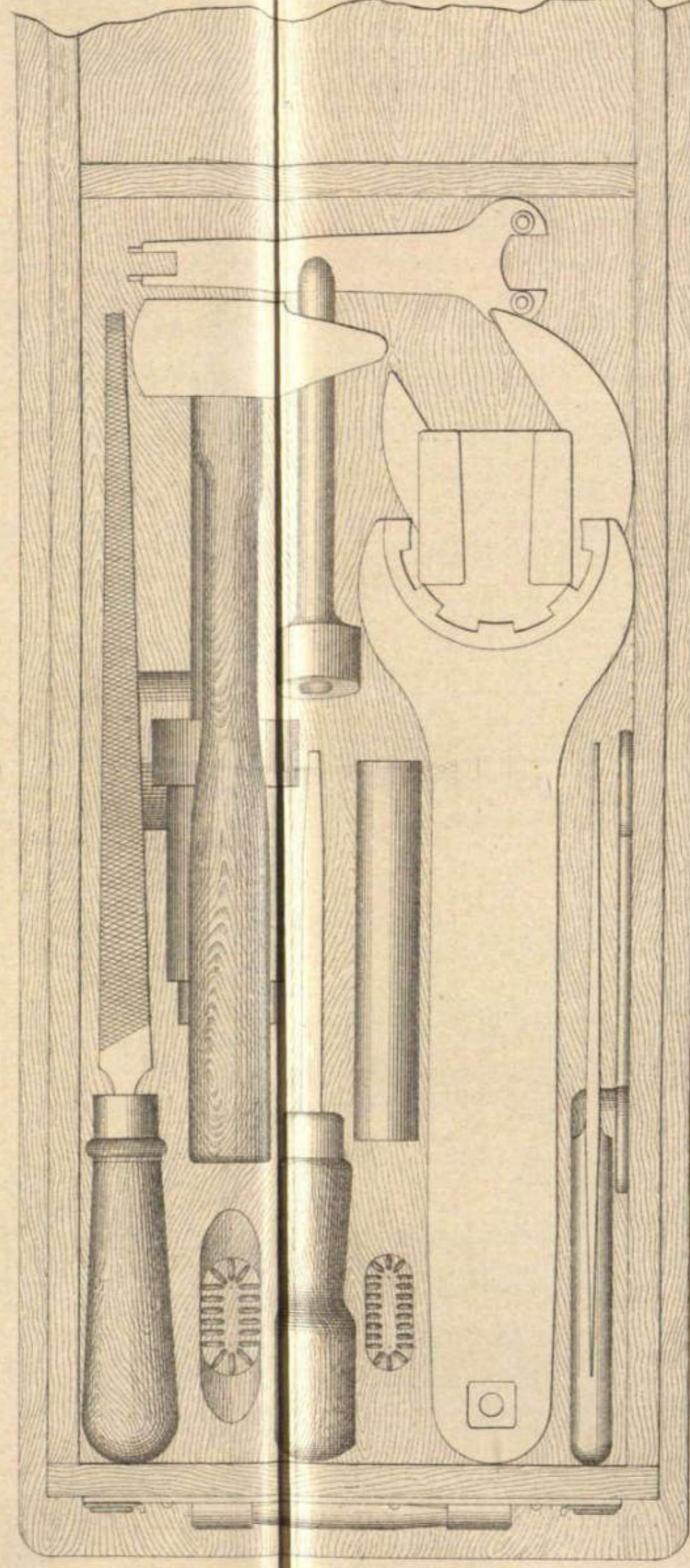

Nº 5 Armón de Carro.

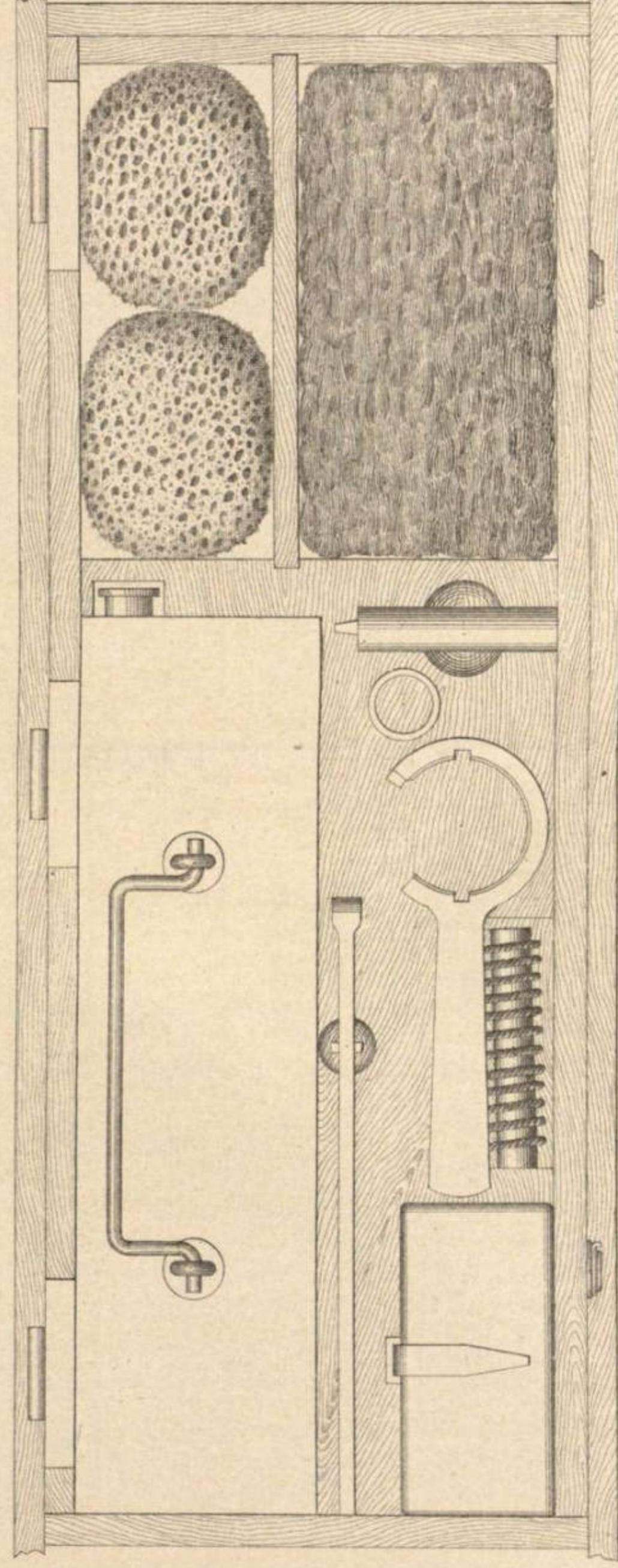

ACCESORIOS PARA EL MATERIAL DE CAMPAÑA Md. 1906.
CAJAS DE RETROTREN DE CARRO.

Nº 3.

Escala 6/10.

Nº 2.

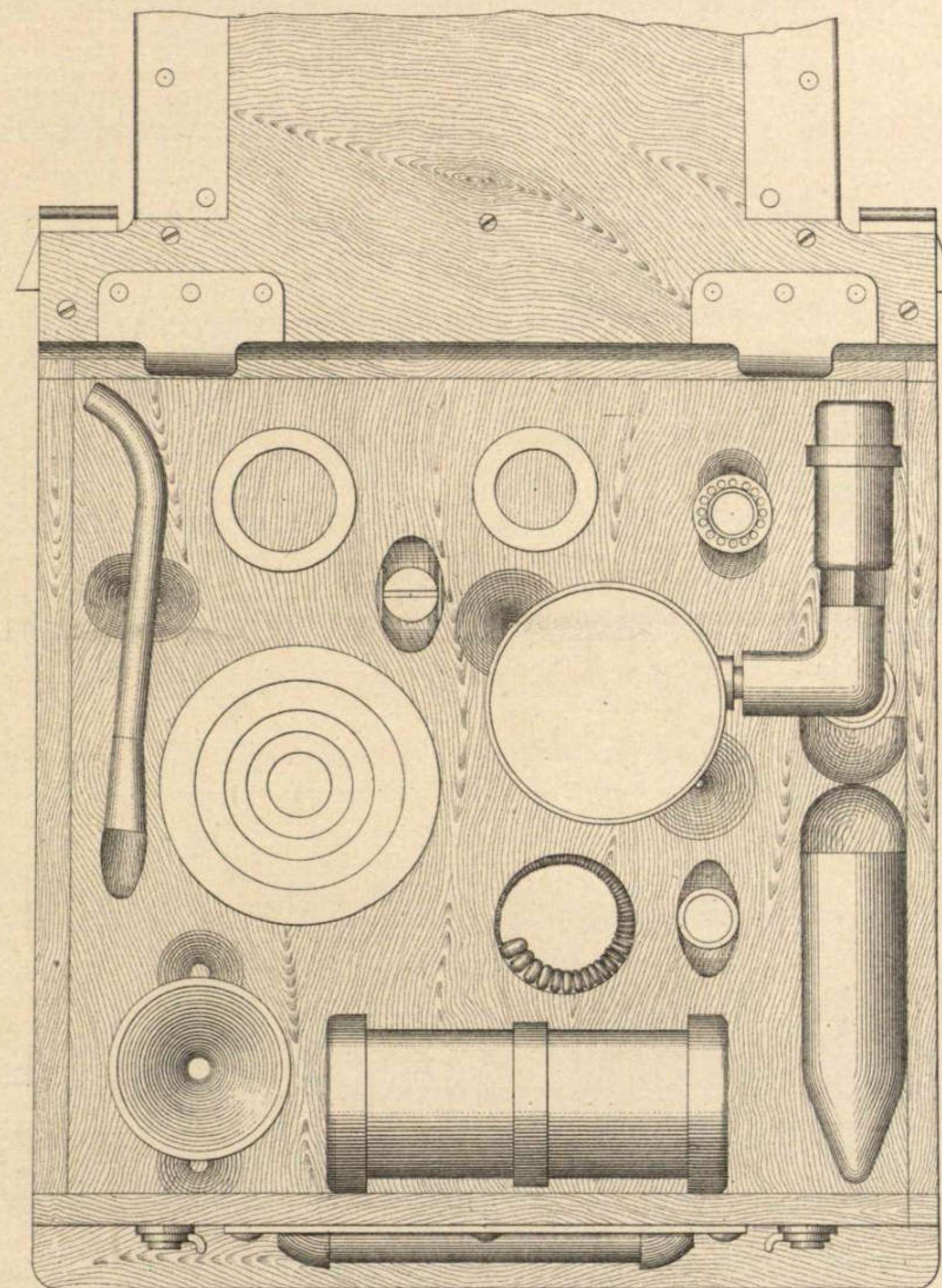
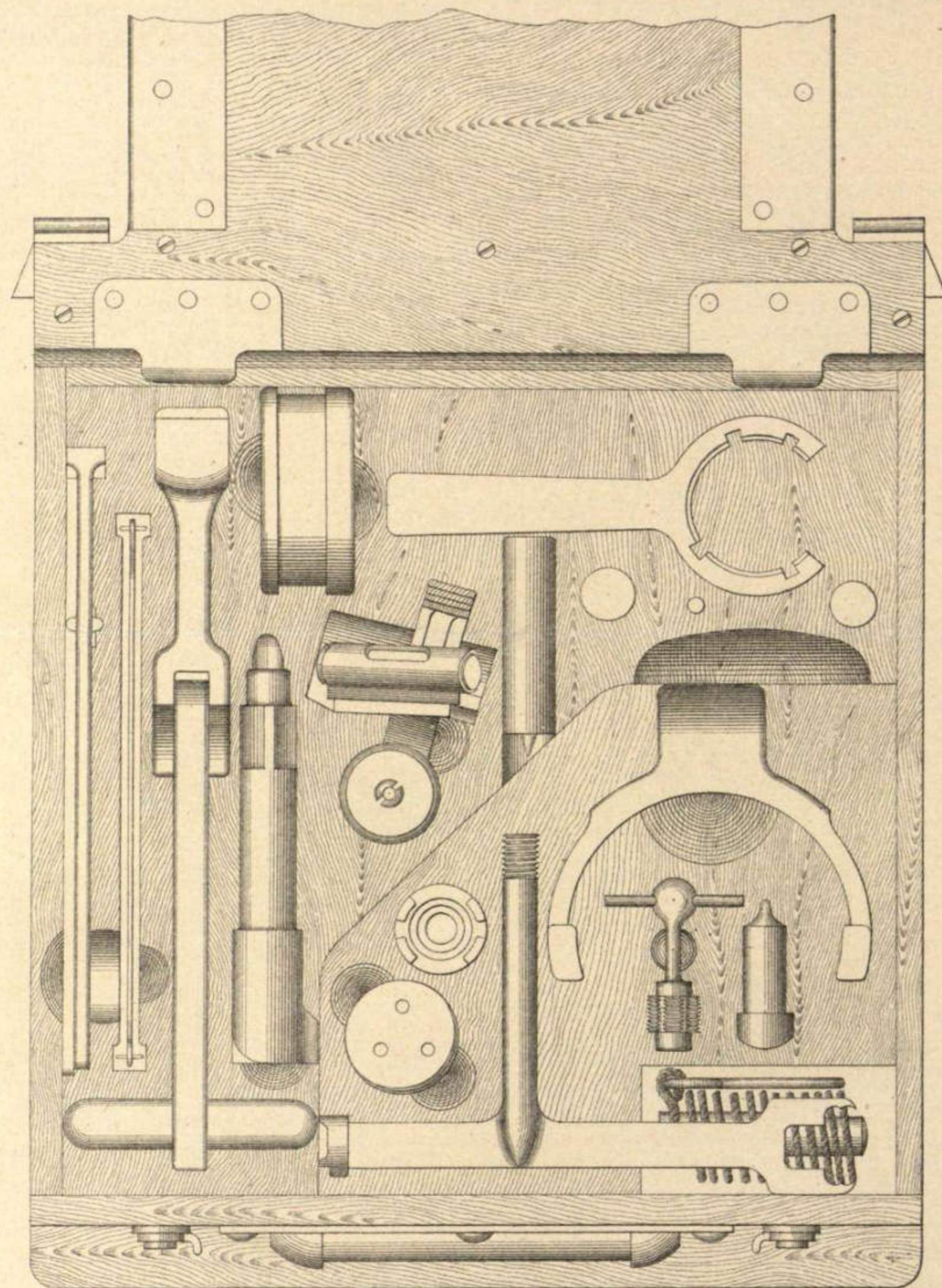

GONIOMETRO DE PIEZAS PARA CAÑÓN Ac. Tr. DE 7'5 cm. DE CAMPAÑA Md. 1906

Escala 8/10

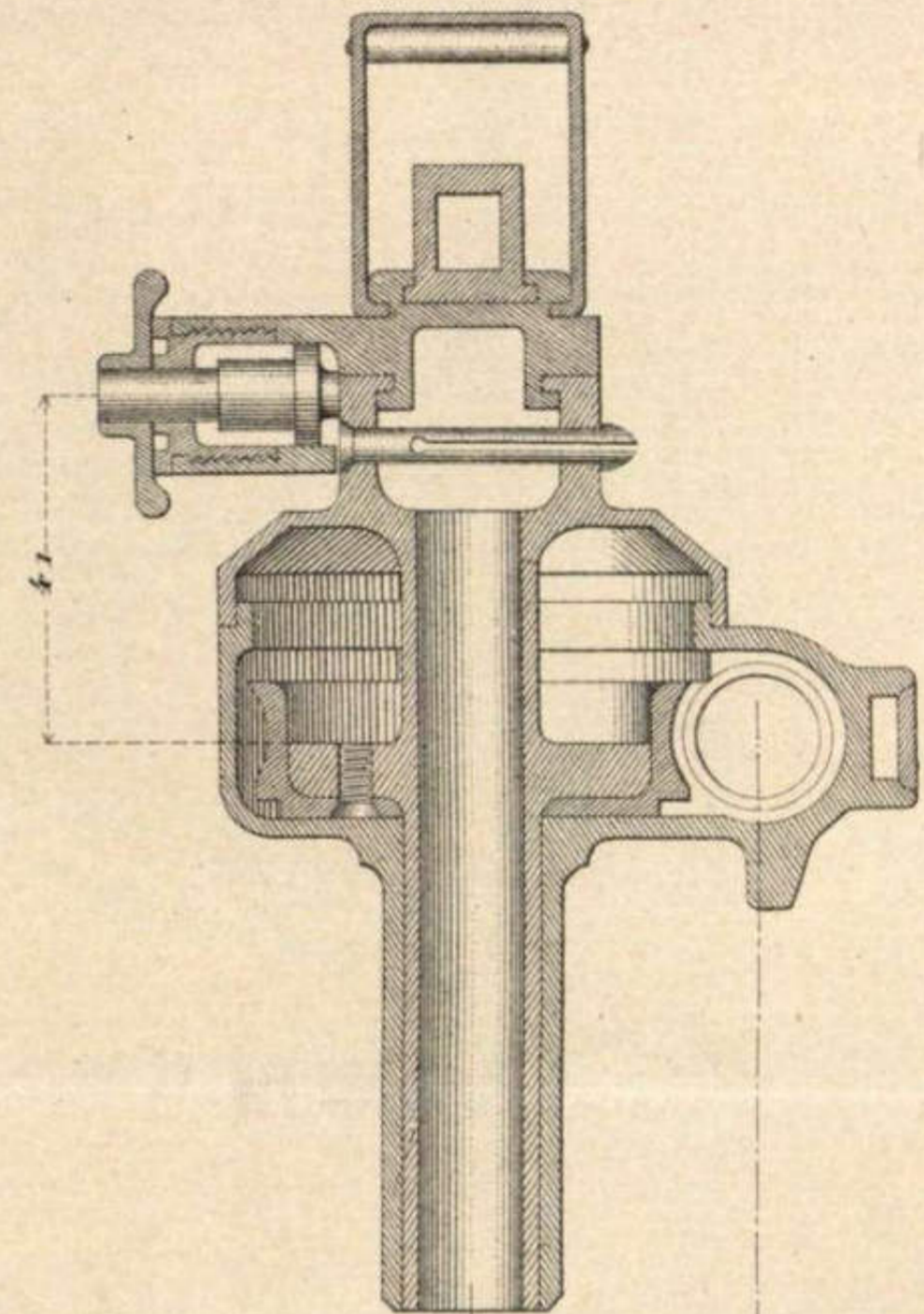
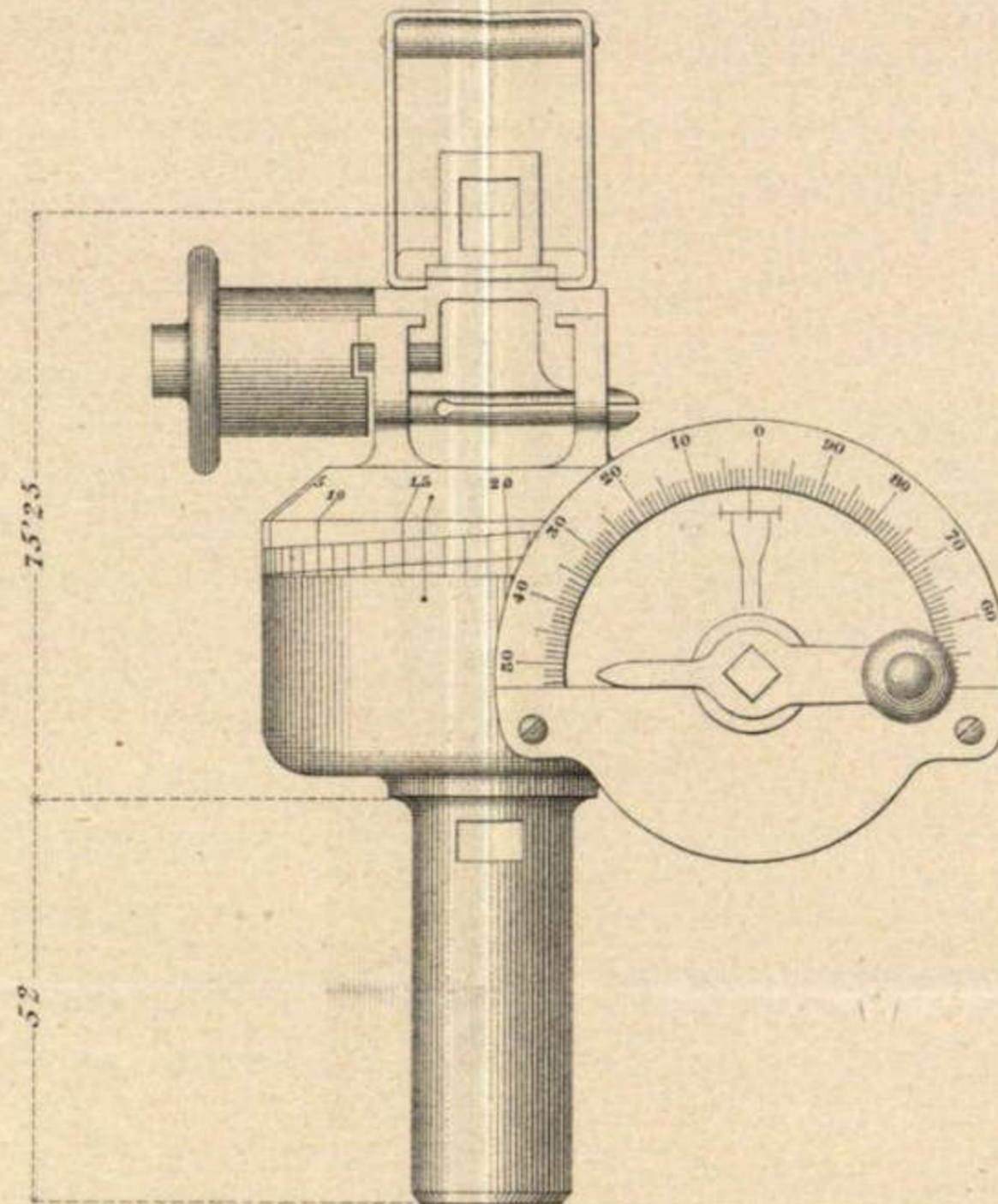
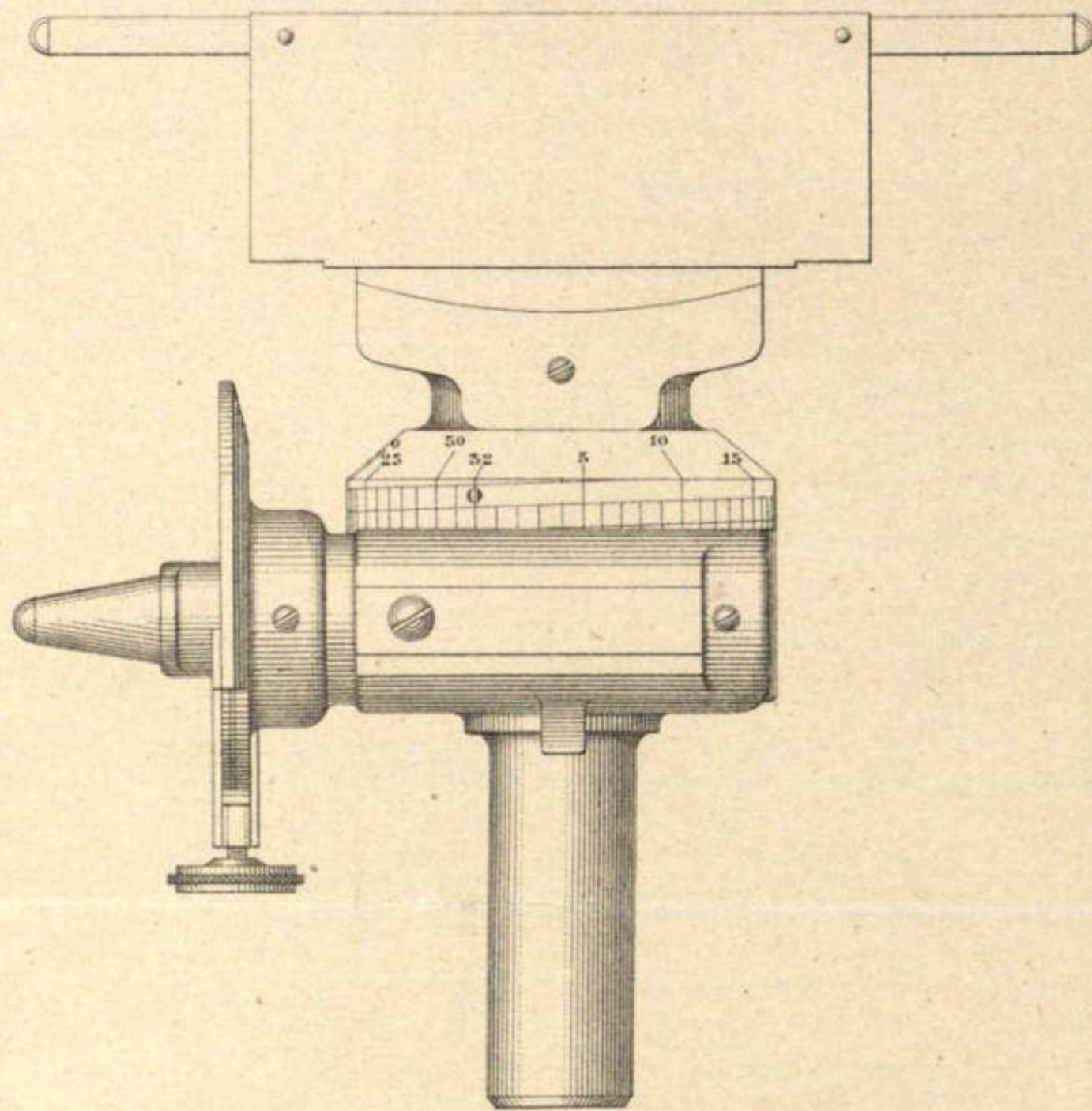

Nivel para los angulos de situación.

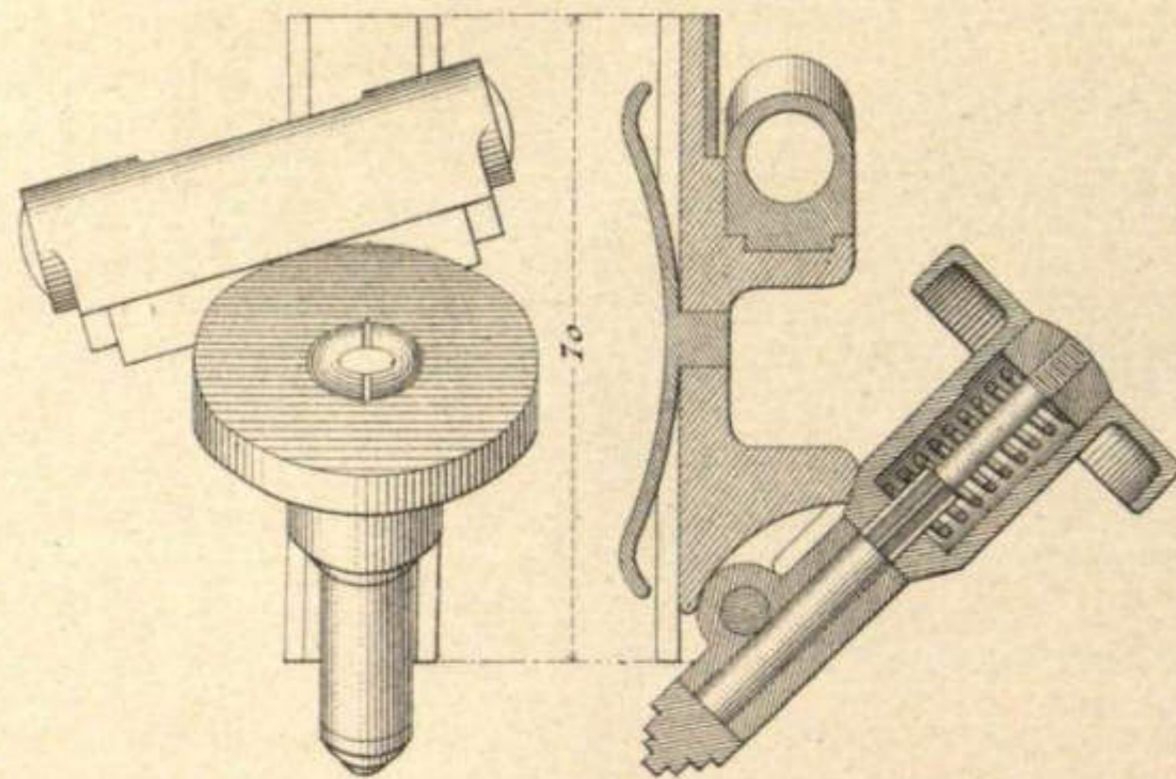

Regleta de dirección (5/10)

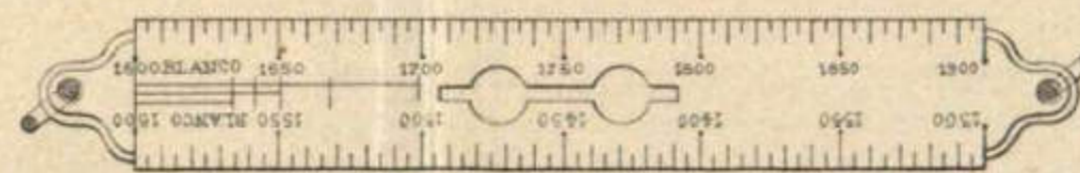

(5/10)

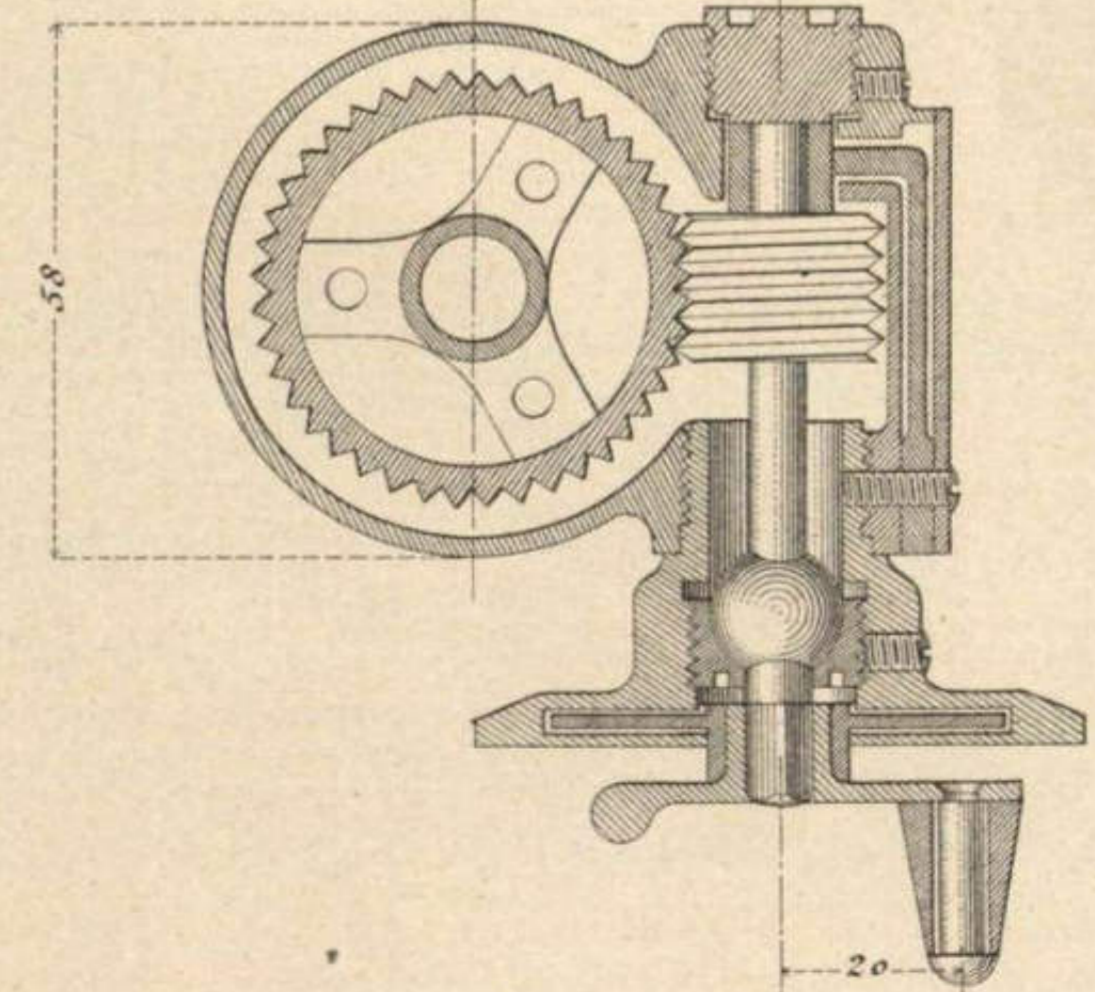
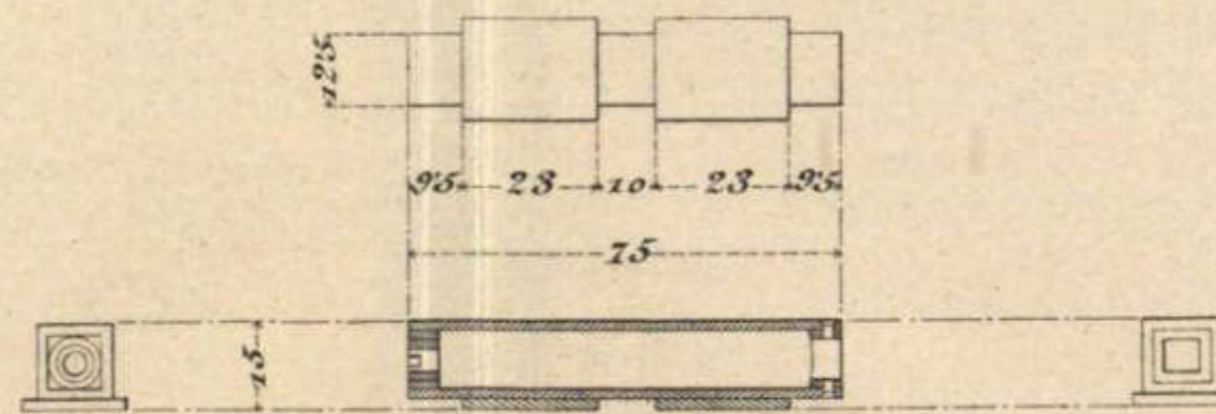

ANTEOJO DE BATERÍA PARA CAÑÓN T. r. DE 7' 5 cm. DE CAMPAÑA Md. 1906.

Escala 6/10

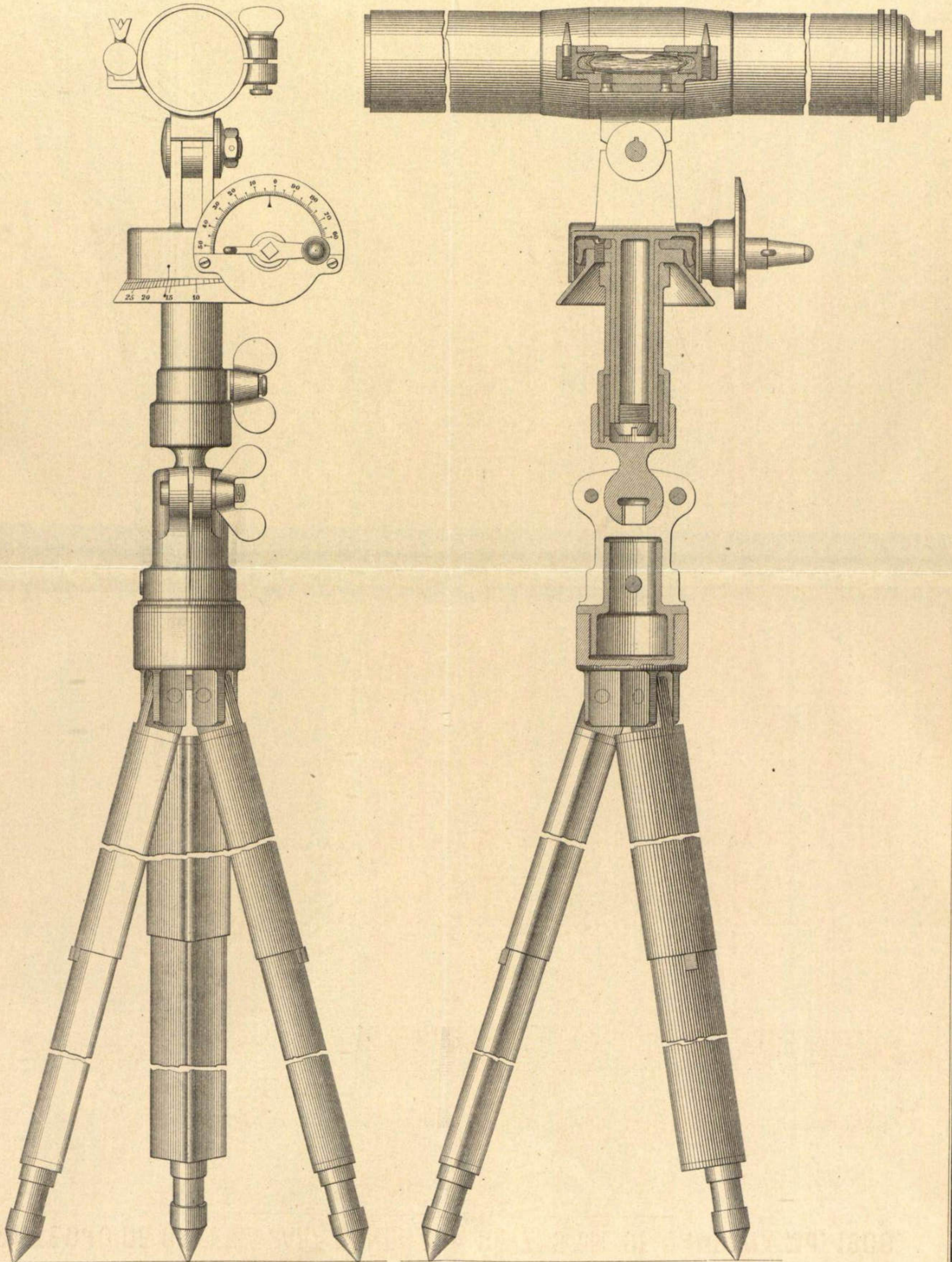

MATERIAL DE CAMPAÑA Md. 1906.

CARRO DE BATERÍA N.º 2.

Escala 1/15.

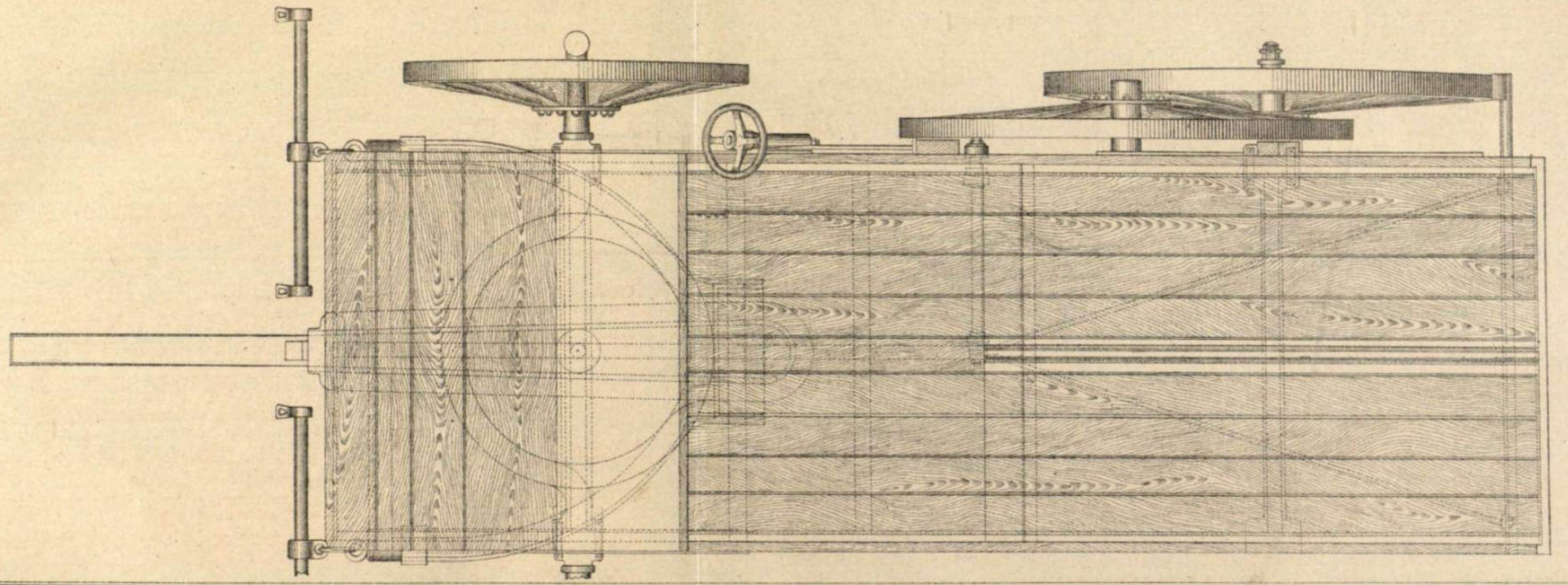
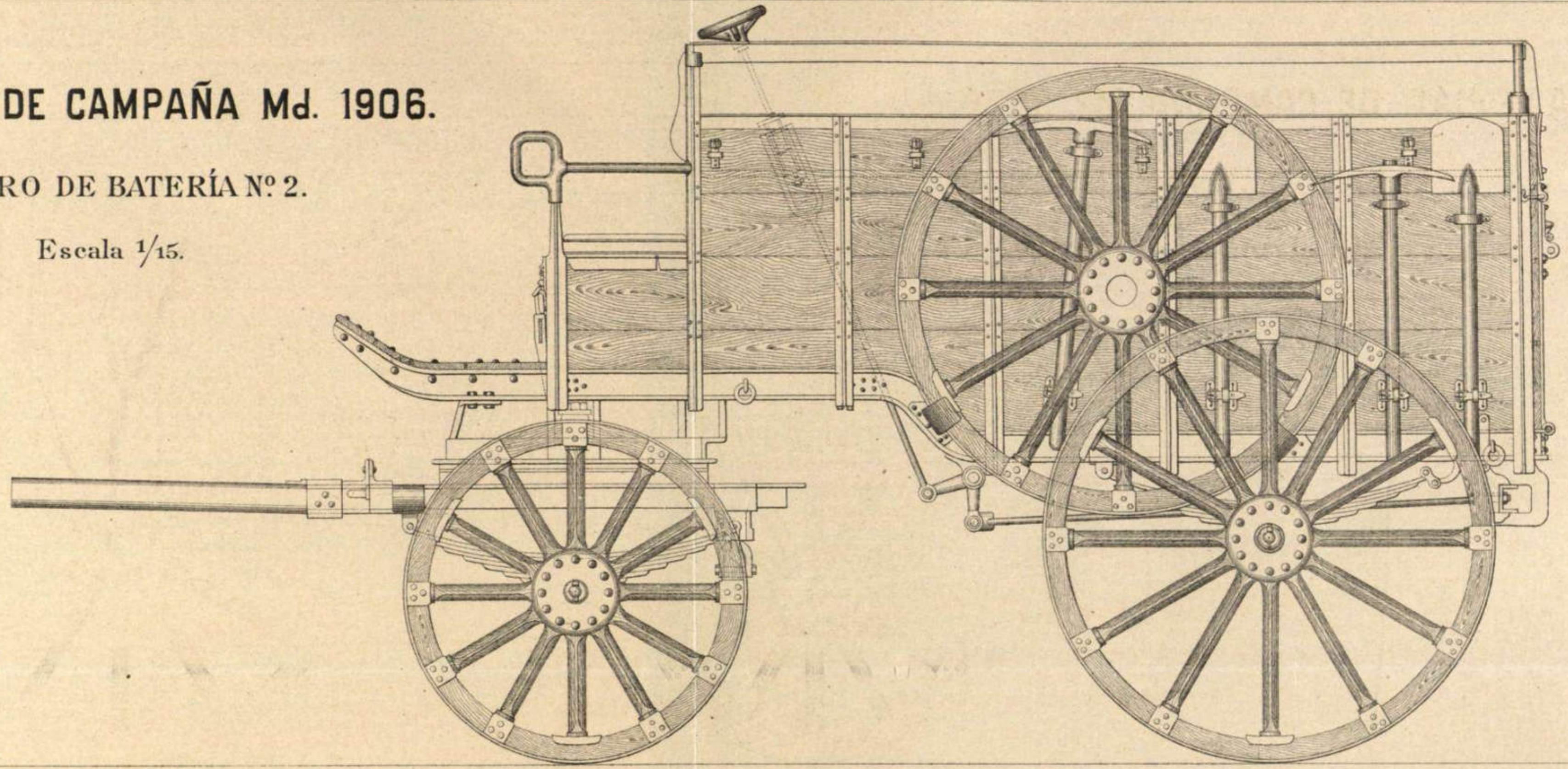

45. 6a

Biblioteca de la Academia de Infanteria
CLASIFICACION 1^o 3^o
Estante 14. Tabla 7^o Núm 3135
Núm. Anterior.....
1929

